

OPERATOR'S MANUAL

650293-X

INCLUDE MANUALS: 67072-X PNEUMATIC CONTROLLER ASM. (97999-596),
6661AX-X-C 1" NON-METALLIC DIAPHRAGM PUMP (97999-20)

RELEASED: 2-16-94
REVISED: 9-15-00
(REV. C)

650293-X METERING SYSTEM USING 1" NON-METALLIC DIAPHRAGM PUMP (PNEUMATIC COUNTDOWN TYPE)

MODEL	BASIC PUMP	FLUID SERVICE KIT	DISP./ CYC GAL. (CC)
650293-1	6661A3-344-C	637161-44-C	.165 (624)
650293-2	6661A3-3EB-C	637161-44-C	.170 (643)

USE SERVICE KIT 637118-C FOR AIR SECTION REPAIR

GENERAL DESCRIPTION

The Pneumatic Controller Asm. provides logic control for preset dispensing. When installed on a diaphragm pump it can monitor the diaphragm pump pulse or cycle and to allow the user to accurately control the number of cycles the pump will produce. This will effectively allow a preset and repeatable amount of material to be dispensed through the pumping system.

The 650293-X Series of Special 1" Diaphragm Pumps are similar to Standard Models of 6661AX-XXX-C Diaphragm Pumps. A 6661AX-X-C Operator's Manual is to be used for General Information, Installation, Operation, and Maintenance.

Special Models and their Standard Model counterpart are shown in the chart. Refer to the standard 6661AX-X-C Operator's Manual for Service Kits and other information.

Special parts involved in the model are shown below.

OPERATION

REFER TO 67072 PNEUMATIC CONTROLLER MANUAL FOR OPERATION

NOTE: For best results operate the pump at 30 - 90 PSI (2 - 6.2 bar). Fluctuations in the air pressure can affect the displacement per cycle. Once the desired displacement is achieved, keep the air pressure as constant as possible.

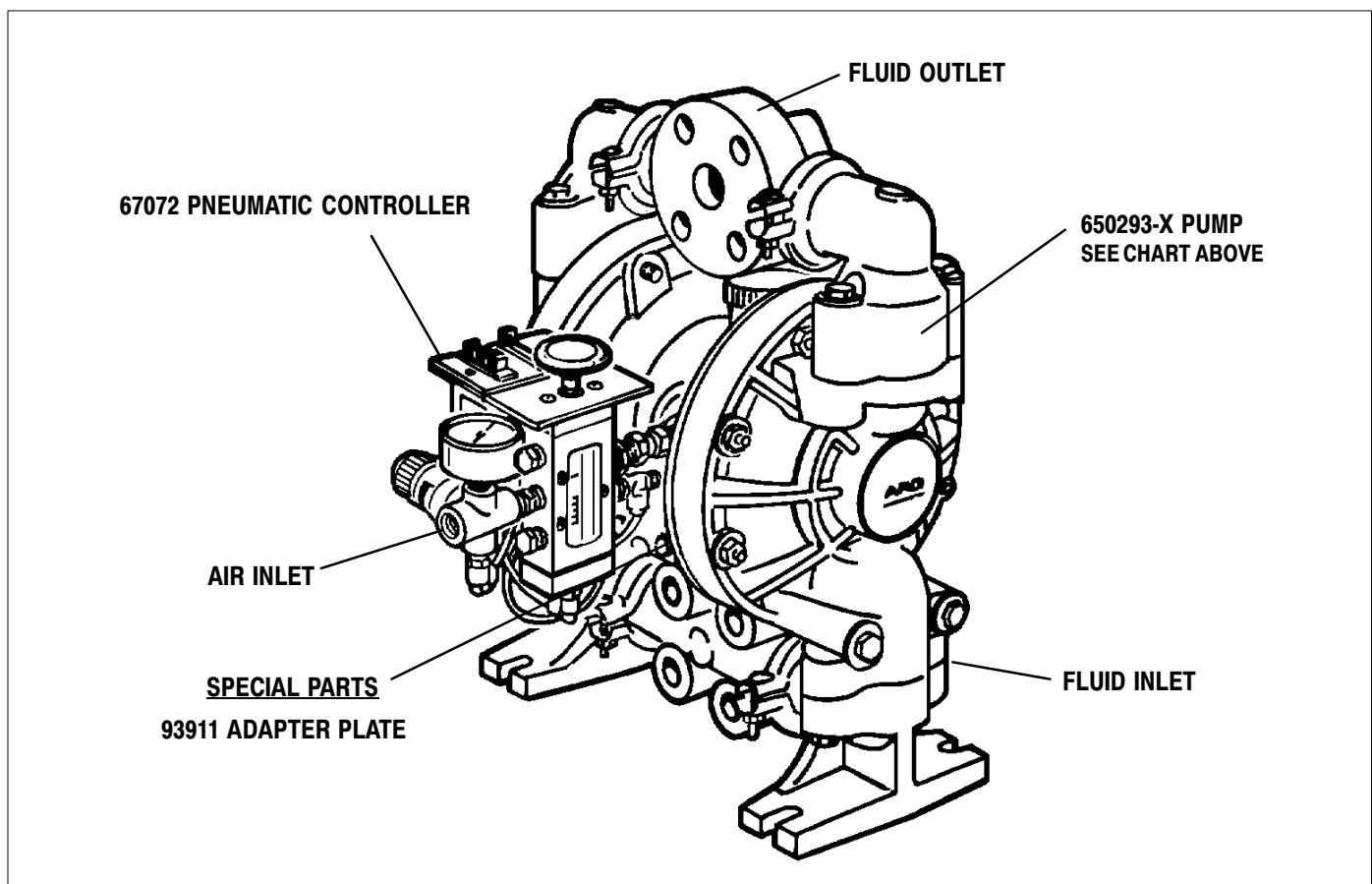

PN 97999-598

INGERSOLL-RAND COMPANY
P.O. BOX 151 • ONE ARO CENTER • BRYAN, OHIO 43506-0151
☎ (419) 636-4242 • FAX (419) 633-1674 ©2000 • PRINTED IN U.S.A.

