

IEEE 802.3af
Power over Ethernet Splitter

POE-152S-5V/12V

User's Manual



Trademarks

Copyright © PLANET Technology Corp. 2006.
Contents subject to revision without prior notice.
PLANET is a registered trademark of PLANET Technology Corp. All other trademarks belong to their respective owners.

Disclaimer

PLANET Technology does not warrant that the hardware will work properly in all environments and applications, and makes no warranty and representation, either implied or expressed, with respect to the quality, performance, merchantability, or fitness for a particular purpose.

PLANET has made every effort to ensure that this User's Manual is accurate; PLANET disclaims liability for any inaccuracies or omissions that may have occurred.

Information in this User's Manual is subject to change without notice and does not represent a commitment on the part of PLANET. PLANET assumes no responsibility for any inaccuracies that may be contained in this User's Manual. PLANET makes no commitment to update or keep current the information in this User's Manual, and reserves the right to make improvements to this User's Manual and/or to the products described in this User's Manual, at any time without notice.

If you find information in this manual that is incorrect, misleading, or incomplete, we would appreciate your comments and suggestions.

FCC Warning

This equipment has been tested and found to comply with the limits for a Class B digital device, pursuant to Part 15 of the FCC Rules. These limits are designed to provide reasonable protection against harmful interference when the equipment is operated in a commercial environment. This equipment generates, uses, and can radiate radio frequency energy and, if not installed and used in accordance with the Instruction manual, may cause harmful interference to radio communications. Operation of this equipment in a residential area is likely to cause harmful interference in which case the user will be required to correct the interference at his own expense.

CE Mark Warning

This is a Class B product. In a domestic environment, this product may cause radio interference, in which case the user may be required to take adequate measures.

WEEE Warning



To avoid the potential effects on the environment and human health as a result of the presence of hazardous substances in electrical and electronic equipment, end users of electrical and electronic equipment should understand the meaning of the crossed-out wheeled bin symbol. Do not dispose of WEEE as unsorted municipal waste and have to collect such WEEE separately.

Revision

PLANET IEEE 802.3af Power over Ethernet Splitter User's manual

FOR MODELS: POE-152S-5V/12V

REVISION: 1.0 (DECEMBER.2006)

Part No.: EM_POE152Sv1 (2080-A31120-001)

TABLE OF CONTENTS

1. INTRODUCTION	4
1.1 CHECKLIST	4
1.2 ABOUT THE POWER OVER ETHERNET SPLITTER	4
1.3 FEATURES	4
1.4 SPECIFICATION	5
1.5 PRODUCT OUTLOOK.....	5
2. HARDWARE INSTALLATION	6
2.1 BEFORE INSTALLATION	6
2.2 POE-152 AND POE-152S, THE IEEE 802.3AF INJECTOR AND SPLITTER INSTALLATION.....	7
2.3 CONNECT WITH IEEE 802.3AF DEVICES.....	8
3.TROUBLESHOOTING	9
APPENDIX A NETWORKING CONNECTION	10
A.1 SWITCH'S RJ-45 PIN ASSIGNMENTS	10
A.2 RJ-45 CABLE PIN ASSIGNMENT	10

1. INTRODUCTION

1.1 Checklist

Thank you for purchasing our POE-152S IEEE 802.3af Power over Ethernet Splitter, your Power over Ethernet Splitter package shall contain following contents:

Check the contents of your package for following parts:

- Power over Ethernet Splitter x 1
- User's manual CD x 1
- DC Plug Cable x 2
- 15cm UTP straight network cable x 1

If any of these pieces are missing or damaged, please contact your dealer immediately, if possible, retain the carton including the original use them against to repack the product in case there is a need to return it to us for repair.

1.2 About the Power over Ethernet Splitter

The PLANET POE-152S is an IEEE 802.3af Power over Ethernet device that split the 48V DC over the Ethernet cable into 5/12V DC power output. Work with the IEEE 802.3af power source equipment (PSE), the POE-152S frees the device deployment from restrictions due to power outlet locations, which eliminate the costs for additional AC wiring and reduces the installation time.

When the PSE inserts DC Voltage into the CAT 5 cable, it allows the cable between the PSE and POE-152S to transfer data and power simultaneously. The maximum distance between the PSE and POE-152S is 100M. With being installed, the PSE combines the Ethernet digital data with power over the twisted pair cables as an injector, and POE-152S, the splitter, shall separate the digital data and the power into two outputs.

With IEEE 802.3af Power over Ethernet being installed, the system administrator only has to use a single RJ-45 Ethernet cable to carry both power and data to each device. The POE-152S also have the benefits of cost saving, as well as ease for networking planning and higher reliability. Furthermore, upon any IEEE 802.3af being installed, the POE-152S can make the connection while migrating or splitting the power and the Ethernet digital packets. Providing two kinds of DC output, the POE-152S offers 2.5A and 1A DC for current model POE-152S-5V and POE-152S-12V.

1.3 Features

- ◆ Complies with IEEE 802.3af, Power over Ethernet, IEEE 802.3/802.3u/802.3ab 10/100/1000Base-T
- ◆ Splits the 48V DC power over RJ-45 Ethernet cable into different DC output
- ◆ LED indicators power input indication
- ◆ Distance up to 100 meters
- ◆ Choice of splitter for 5V DC and 12V DC
- ◆ Auto-detect of POE IEEE 802.3af equipment, protect devices from being damaged by incorrect installation
- ◆ Works with EIA568, category 5/5e/6,2/4-pair cables for 10Base-T or 100Base-TX and 1000Base-T

1.4 Specification

Model	POE-152S
Ethernet Connector	2 x RJ-45 (1 for Data + DC in, 1 for Data out)
Ethernet Data Rate	10/100/1000Mbps (vary on Ethernet device attached)
Output Voltage/Current	Vary on model: POE-152S-5V: 5VDC, 2.5A max. POE-152S-12V: 12VDC, 1A max.
Number of Device can be powered	1
Ethernet Cable	TIA/EIA-568, Category 5/5e/6 cable
LED indicator	1 x POE ready/in-use
Operating environment	0~50 Degree C, 5%~90%RH
Storage environment	-20~70 Degree C, 5%~90%RH
Dimension (W x D x H)	73 x 55 x 24 mm
Weight	50g
Emission	FCC Class B, CE mark
Standard Compliance	IEEE 802.3 Ethernet IEEE 802.3u Fast Ethernet IEEE 802.3ab Gigabit Ethernet IEEE 802.3af Power over Ethernet

1.5 Product Outlook

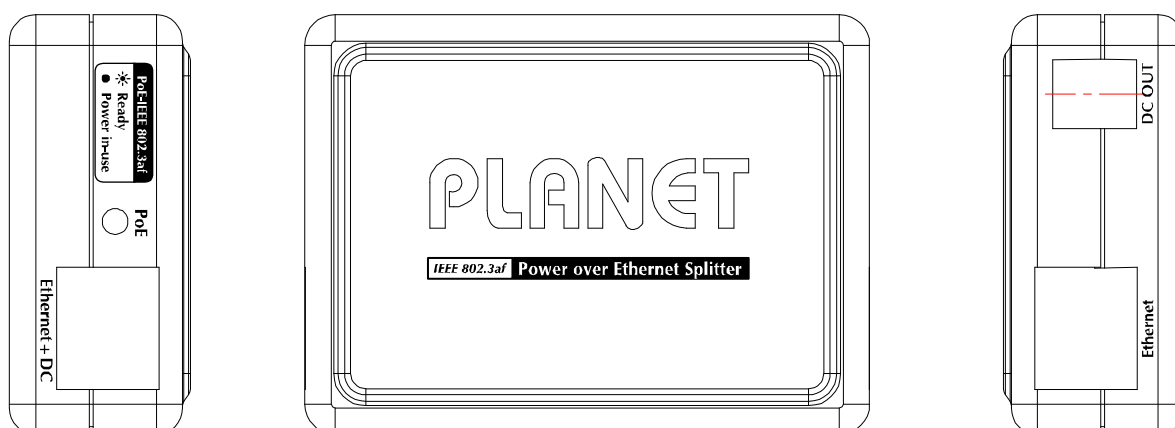

LED definition:

LED	Color	Function
PoE ready / in-use	Green	Lights to indicate the port is providing 48VDC in-line power.

2. HARDWARE INSTALLATION

These products provide three different running speeds – 10Mbps, 100Mbps,1000Mbps. in the same device and automatically distinguish the speed of incoming connection.

This section describes the hardware features of POE-152S. Before connecting any network device to the POE-152S, read this chapter carefully.

2.1 Before Installation

Before your installation, it is recommended checking your network environment. If there is any issue for your install a networked device where is very difficult to find a power socket for your AC-DC adapter, the POE-152S can work with POE-152 IEEE 802.3af Power over Ethernet Injector with an AC-DC adapter(DC 48V input). The POE-152S provide you a way to provide DC power for this Ethernet device conveniently and easily.

The10/100/1000Mbps speed duplex mode from Ethernet port of POE-152S depends on which Ethernet device attached.

 **Notice:**

The POE-152 and POE-152S can be installed in pair. However, the use of third-party device is allowed if the device complied with IEEE 802.3af standard.

2.2 POE-152 and POE-152S, the IEEE 802.3af Injector and Splitter installation

1. Connect a standard network cable from “Ethernet+DC” of POE-152 to “Ethernet+DC” of POE-152S. The POE LED of POE-152 / POE-152S will light on continuance. The screen in Figure 1 appears.

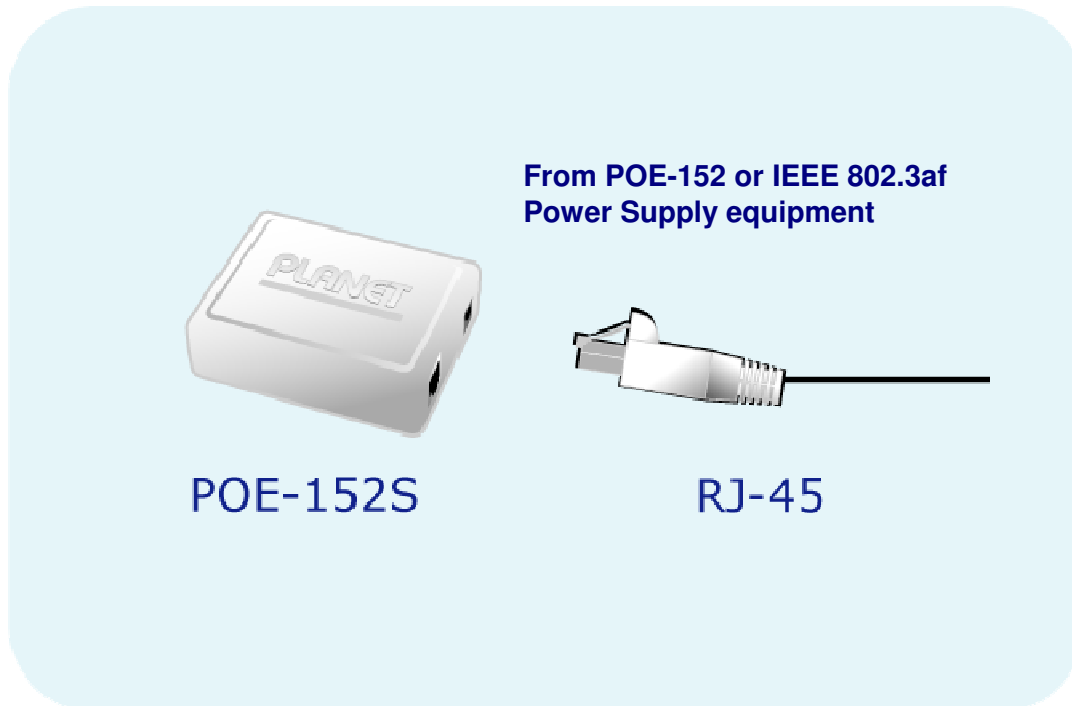

Figure 1: Connection to POE-152 or IEEE 802.3af POE equipment

2. Connect the UTP cable in the package from “Ethernet” of POE-152S to the RJ-45 port of remote device.
3. Connect proper DC plug from “DC OUT” of POE-152S to remote device.
4. Power on the remote device and the LED indicator on POE-152S will remains on, the screen in Figure 2 appears.

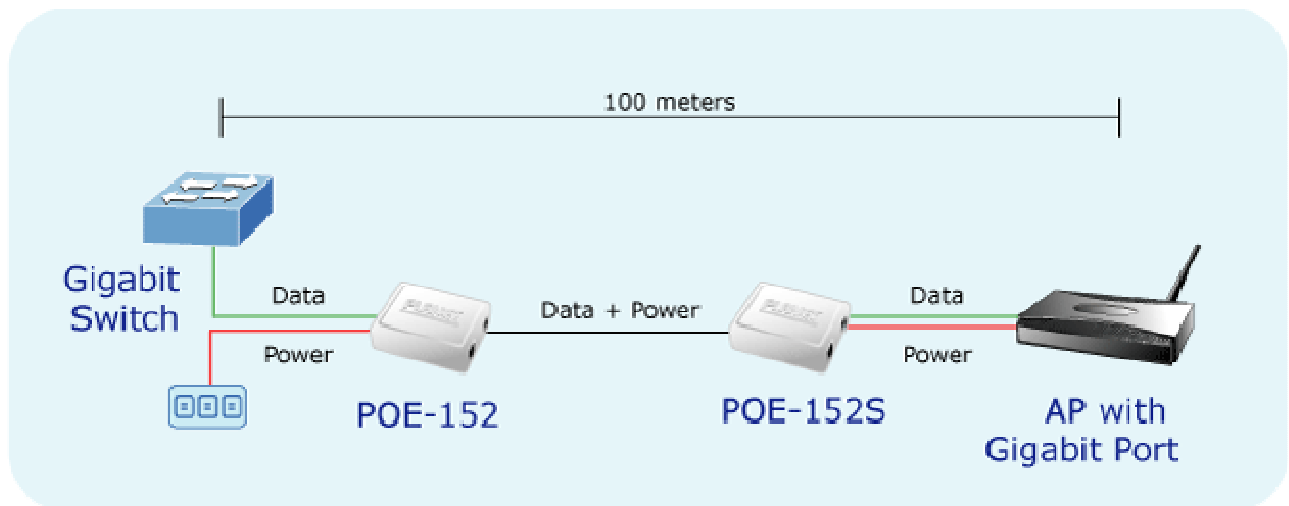

Figure 2: Connection architecture over POE-152/152S

Notice:

1. The POE-152S only accept IEEE 802.3af power supply equipment, any other in-line power device sending power through UTP wire connects to POE-152S may cause the POE-152S malfunction.
2. Please ensure the output voltage is correct before applying power to remote device.

2.3 Connect with IEEE 802.3af devices

The POE-152S can also provide the alternative to make the non- IEEE 802.3af devices the possibility to connect with an IEEE 802.3af in-line power device like Power over Ethernet Switch, then connect proper DC plug from "DC OUT" of POE-152S to remote device. The screen in Figure 3 appears.

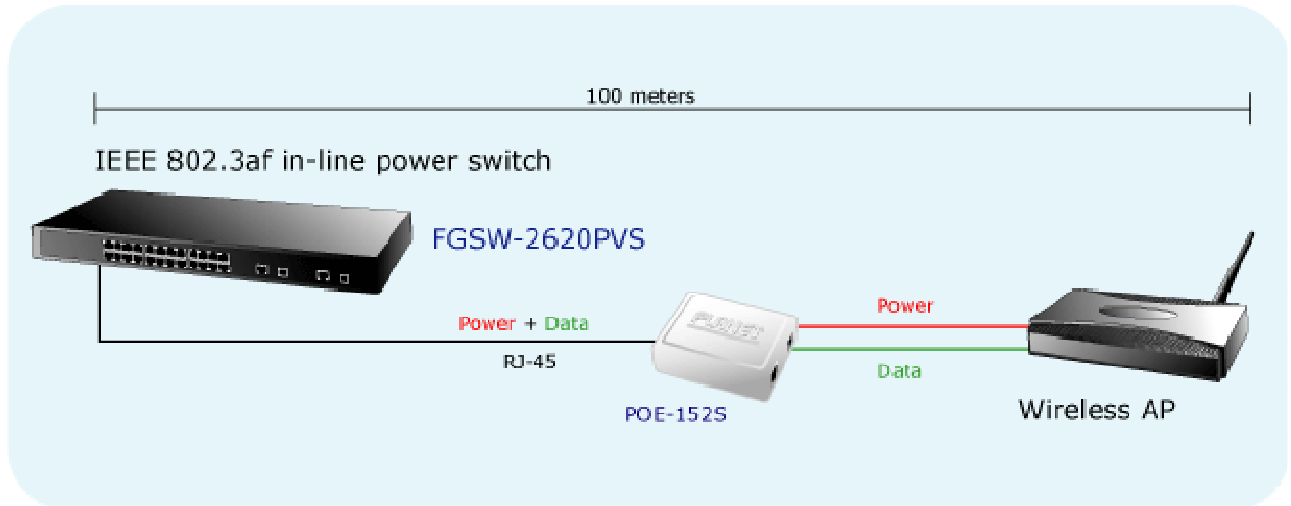

Figure 3: Connect to IEEE 802.3af device

Once POE-152S detects the existence of an IEEE 802.3af device, the LED indicator will be steady; ON to shows it is getting power.

3.TROUBLESHOOTING

This chapter contains information to help you solve issues. If the POE-152S is not functioning properly, make sure the POE-152S was set up according to instructions in this manual.

The PoE LED is not lit

Solution:

Check the cable connection between POE-152S and IEEE 802.3af device.

Why the device connected to POE-152S cannot be powered?

Solution:

1. Please check the POE-152S is connect with an IEEE 802.3af complied in-line device like POE-152, and check if the POE LED indicator at POE-152S is steady blink once attach to the IEEE 802.3af in-line power device. Then connect the DC plug cable to the device you would like to power on.
2. Please check the cable type of the connection from one end to the other end. The cable should be an 8-wire UTP, Category 5 or above, EIA568 cable within 100 meters. A cable with only 4-wire, short loop or over 100 meters, all will affect the power supply.
3. Please check the power requirement of the device you would like to power and check the label of the POE-152S if it meets the requirement. There are two models of POE-152S for different power output, DC 5V and DC 12V.
4. Please check the specification of the powered device. If the device is over the specification of POE-152S, the LED indicator of POE-152S will blink instead of stead green. The maximum currents that POE-152S can supply are: 2.5A (5V DC) and 1A (12V DC).

10/100/1000Base-T port link LED is lit, but the traffic is irregular

Solution:

Check that the attached device is not set to dedicate full duplex. Some devices use a physical or software switch to change duplex modes. Auto-negotiation may not recognize this type of full-duplex setting.

APPENDIX A NETWORKING CONNECTION

A.1 Switch's RJ-45 Pin Assignments

1000Mbps, 1000Base T

Contact	MDI	MDI-X
1	BI_DA+	BI_DB+
2	BI_DA-	BI_DB-
3	BI_DB+	BI_DA+
4	BI_DC+	BI_DD+
5	BI_DC-	BI_DD-
6	BI_DB-	BI_DA-
7	BI_DD+	BI_DC+
8	BI_DD-	BI_DC-

10/100Mbps, 10/100Base-TX

RJ-45 Connector pin assignment		
Contact	MDI Media Dependant Interface	MDI-X Media Dependant Interface -Cross
1	Tx + (transmit)	Rx + (receive)
2	Tx - (transmit)	Rx - (receive)
3	Rx + (receive)	Tx + (transmit)
4, 5	Not used	
6	Rx - (receive)	Tx - (transmit)
7, 8	Not used	

A.2 RJ-45 cable pin assignment

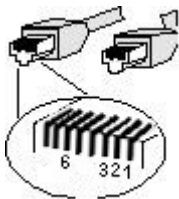

The standard RJ-45 receptacle/connector

There are 8 wires on a standard UTP/STP cable and each wire is color-coded. The following shows the pin allocation and color of straight cable and crossover cable connection:



Figure A-1: Straight-Through and Crossover Cable

Please make sure your connected cables are with same pin assignment and color as above picture before deploying the cables into your network.