

Power Lift & Recline Chair

OWNER'S MANUAL AND LIMITED LIFETIME WARRANTY



The Best Power Lift and Recline Chair Made in the USA 

 **GOLDEN**
technologies
YOUR LIFE IN MOTION



Dear Valued Customer,

Thank you for purchasing this Golden Technologies Power Lift and Recline Chair. UL and CSA certifications insure that our chairs are the safest available. We believe that this product is made from the highest quality components available, is engineered to give you maximum service with minimum maintenance, and is backed up with the strongest warranty in the industry. We hope that you enjoy years of pleasurable use of your Golden Technologies chair and that this chair becomes a true assist to you in both sitting down and standing up.

Please take a few moments to review this manual to become familiar with the operation of this chair and our warranty. If you need additional information, please call the dealer from whom you purchased this chair.

Also, please note the following safety information: This power lift and recline chair is a piece of medical equipment designed to help you sit down and stand up. Children should not be allowed to operate it without adult supervision. When not in use, the chair should be kept in the sitting position.

Again, thank you for selecting this Golden chair.

Sincerely,

A handwritten signature in cursive script that reads "Robert Golden".

Robert Golden
President



SAFETY INSTRUCTIONS

Your Golden power lift chair is a piece of medical equipment. Therefore, you are required to exercise caution when operating it to ensure your personal safety and that of others around you. The following are rules for safe operation of your Golden Power Seat Lift Chair.

- **DO NOT ALLOW CHILDREN OR PETS NEAR THE CHAIR WHILE OPERATING.**
- **Make sure all obstacles are clear from under the footrest, under chair or behind chair before reclining or descending from lift position.**
- **DO NOT place fingers or hands between seat cushions, and inside arm of chair while sitting in or while chair is plugged in.**
- **Before retrieving fallen objects: make sure chair is in sitting position and chair is unplugged**
- **DO NOT ALLOW CHILDREN TO PLAY WITH OR OPERATE THE CHAIR AT ANY TIME.**
- **DO NOT ALLOW LIQUIDS TO SPILL ONTO SWITCH OR OTHER ELECTRICAL COMPONENTS.**
- **DO NOT allow anyone to sit on your lap, or on the arm of the chair, or on the footrest while operating the chair.**
- **Please unplug your chair BEFORE you clean or retrieve fallen objects from under it.**
- **IF CHAIR DOES NOT OPERATE AND YOU CAN'T FIND THE PROBLEM, UNPLUG THE CHAIR AND CALL YOUR DEALER FOR ASSISTANCE.**

CHAIR INSTRUCTIONS

While standing next to your chair, press the lift button on the control switch to raise the chair to a height you can sit against. This height will vary from person to person depending on the individual's needs or preference. When the chair is at the desired height, lean against the chair seat and press the recline button on the control switch. As the chair continues downward move yourself into a sitting position. Release the button on the switch when the chair is firmly set on the floor.

To recline, continue to press the recline button and lean back as chair reclines. You can control the reclining movement with the switch by letting go of the button when you reach the desired position.

To stand up press the lift button. If you are in a reclined position the chair will move to a seated position, then slowly and gently begin to rise. As the chair slowly rises gradually shift your weight forward. You can steady yourself by holding on to the arms of the chair as it rises with you. When the chair reaches a height that enables you to easily stand, release the switch. You may leave your chair in this position as it should be the same height you need to lower yourself to a sitting position.

MAKING POWER CONNECTIONS IN YOUR NEW LIFT CHAIR

1. Remove AC/DC adapter (transformer) from packaging located under base of chair.
2. Place two 9 volt alkaline batteries (not included) into the slots provided on the underside of the adapter. Install the wire connections on each battery.
3. Locate the extension wire secured to the shaft of the lift motor beneath the chair. Connect the female end of the wire to the power cord coming out of the motor. Connect the male end of the wire to the transformer.
4. Make sure all connections are tight. Plug the transformer plug into a standard wall outlet.

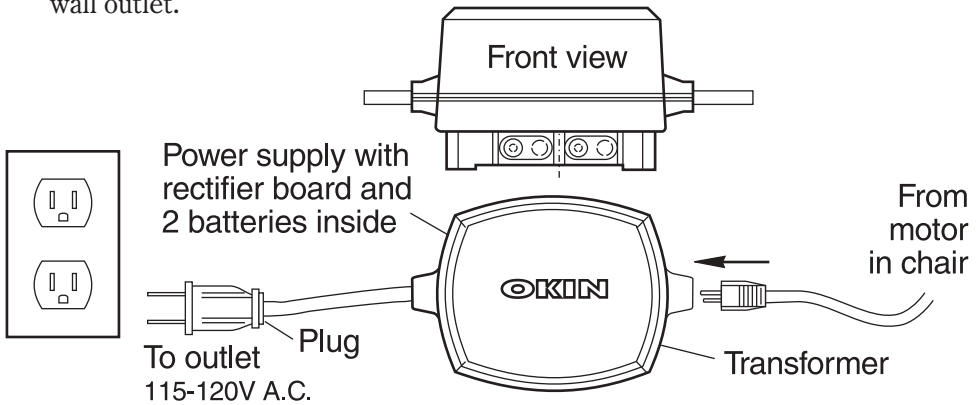

CHAIR LOCATION

You will want to place your chair in the room where it will be most convenient for you, such as near the television, radio, reading light, end table, or other furniture. Leave enough space between back of chair and wall or other obstruction to allow chair to recline (about 14 inches). (Recline space needed may vary based on chair model.)

Do not allow any objects to restrict movement of the footrest. Some carpets have a high plush pile that can rub on the bottom of the footrest. This situation can damage the mechanism. You can correct this situation by turning the levelers (located under the front of the chair) to raise the footrest enough to clear the carpet.

Your chair is equipped with a battery back up source. 2-9 volt batteries must be installed. Once used, batteries must be replaced.

Keep the telephone or some means of communicating with someone within reach.

ASSEMBLING/DISASSEMBLING CHAIR BACK TO SEAT BASE

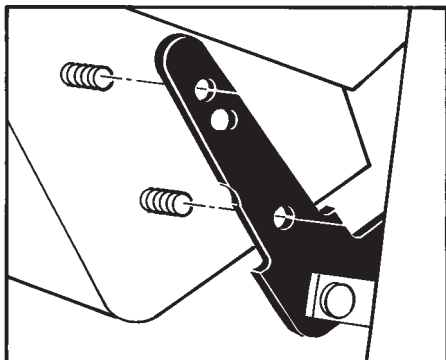
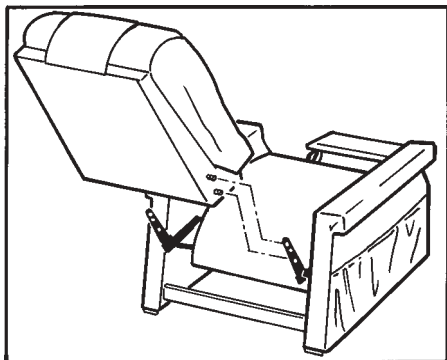

1. Plug in the chair
2. Adjust chair to recline position by pushing the recline button on hand control.
3. Place bolts (located on both sides of the lower back assembly) into the holes in brackets as shown in the illustration.
4. Thread supplied acorn nuts over chair back bolts and tighten securely.

HELPFUL HINTS

Continuous operation of your chair will overheat the motor and trip the thermal-overload safety switch. Give your chair a rest between uses. If you run your chair 5-6 continuous cycles the motor may shut off. If this happens, wait 10-15 minutes and the overload switch will reset and the chair will operate again.

When sitting, resting or rising in chair try to keep yourself centered in the chair. Make sure floor is level or adjust built in levelers on chair so that it sits properly on the floor.

Wipe up spills immediately from fabric and follow with a good upholstery cleaner. Care for the fabric as you would any other piece of fine furniture.

Low voltage can damage the motor. Too many appliances on the same circuit could cause a problem.

Do not smoke while resting in your chair.

Keep canes, walkers, or other items from becoming entangled in the lifting or reclining mechanism.

Should a power outage occur, your chair is designed with a battery back-up system allowing you to return to further the sitting or lift position. You must replace the (2) 9-volt alkaline batteries in the back-up system after each use.

TROUBLE SHOOTING

CHAIR WILL NOT OPERATE:

- Is power cord plugged into a working outlet?
- Verify that the circuit breaker for the outlet that the chair is plugged into is not tripped (outlet power).
- Motor overheated-thermal protector tripped (internal switch) (See page 4)
- Check transformer connection to chair motor & to outlet.
- Is the hand control connection secure? (Located inside chair pocket)
- Control switch damaged

MOTOR KEEPS RUNNING WILL NOT SHUT OFF: (Contact dealer for assistance.)

- Defective control switch
- Defective motor

IF CHAIR DOES NOT OPERATE AND YOU CAN'T FIND THE PROBLEM, UN-PLUG THE CHAIR AND CALL YOUR DEALER FOR ASSISTANCE.

ELECTRICAL INFORMATION

Your new GOLDEN POWER LIFT CHAIR operates on standard household current (115-120V A.C.). Standard models meet both UL, & CSA requirements. Most models have a 110 volt 2 prong polarity plug.

The easy to reach pendant switch control operates both the lift and recline action of your chair. The control switch will only work when you apply pressure.

SERVICE INFORMATION

GOLDEN TECHNOLOGIES has built your Power Lift Chair from sturdy, high quality components so regular maintenance is generally not required.

Should a problem occur, please contact your local dealer.

OPTIONAL TRANQUIL-EASE MASSAGE AND HEAT SYSTEM

Tranquil-Ease® Model HC-3703H

Operation

Instructions:

Plug in speaker jack end of transformer to bottom outside of chair. Then plug the 12V UL/CSA Wall Transformer into the electrical wall outlet. (120 Volts - 60 Hz power).

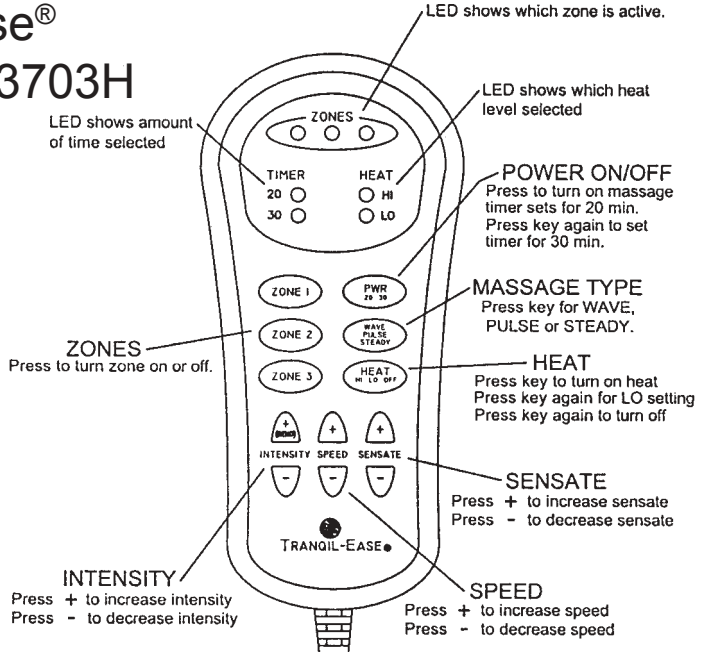

HAND WANDS

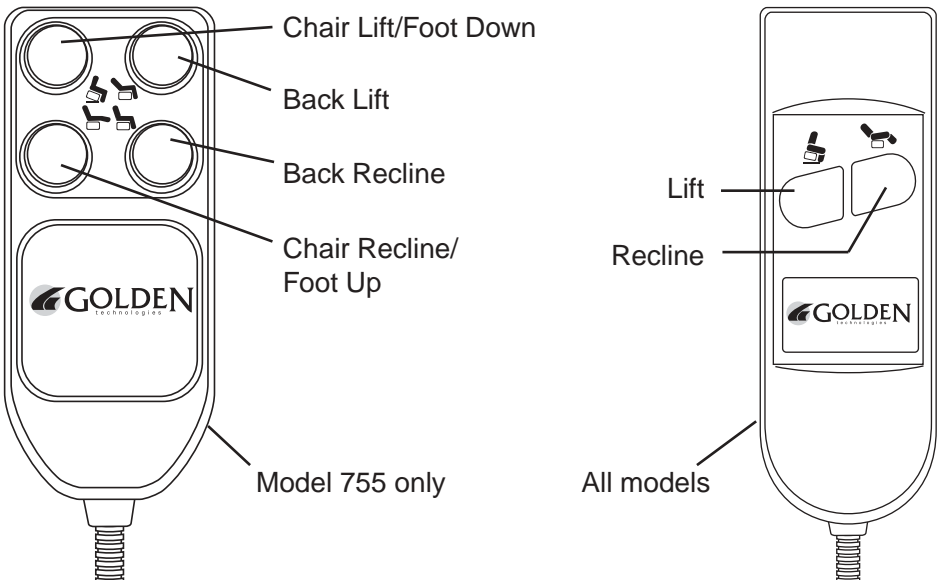

CONSUMER LIMITED LIFETIME AND SEVEN YEAR WARRANTY

GOLDEN, through its authorized distributor / service organization, warrants this chair to original consumer only, against defects in material or workmanship as follows:

LIFETIME WARRANTY

GOLDEN warrants for the lifetime of the chair by the original consumer to repair or replace at their option the Lift Mechanism, Chair Frame and Recliner Mechanism. Labor to replace these parts is covered on all models for three years. The Capri and Monarch are limited to six months.

GOLDEN shall not be responsible or obligated to pay for any costs or expenses for examination of any warranted part nor is Golden to pay for costs for transportation, handling and packaging of the parts or components.

THREE YEAR PARTS WARRANTY

GOLDEN warrants the electrical parts of this chair against defects to original consumer only, for a period of three years from the date of original purchase by a consumer. The Monarch chair has electrical parts warranty of 2 years. The Capri chair is limited to 1 year electrical parts warranty. Labor to replace these parts is covered for one year on all models except Capri & Monarch which are limited to 6 months.

GOLDEN shall not be responsible or obligated to pay for any costs or expenses for examination of any warranted part nor is Golden to pay for costs for transportation, handling and packaging of the parts or components.

LIMITED WARRANTY FOURTH THROUGH SEVENTH YEAR

During the period beginning with the expiration of the full three year parts warranty offered above and continuing through the seventh year after date of original purchase by a consumer, **GOLDEN** will warrant the electrical parts on the following pro-rated basis. Year 4 earns a 35% discount off suggested retail price. Year 5 earns a 25% discount, year 6 a 15% discount and year 7 a 5% discount. By way of example, a part costing \$100.⁰⁰ that needs replacement in year 4 would cost \$65.⁰⁰. **GOLDEN** shall not be responsible or obligated to pay for any costs or expenses for examination and / or service of any warranted part or to pay for costs of transportation, handling and packaging of the chairs and / or parts or components. Capri and Monarch are excluded from this portion of the warranty.

TERMS APPLICABLE TO WARRANTIES

GOLDEN will, at its option, repair and / or replace the defective parts and / or components provided that the warranty parts have not been subjected to misuse, abuse or improper service by the consumer, have not been damaged in transit or handling and / or have not been altered or repaired by unauthorized representatives. This warranty does not include costs for unnecessary service calls, i.e., in-home service calls solely for the purpose of educating the consumer about the product, or finding an unsatisfactory power connection, etc. Please refer to weight capacity chart for specifics.

Jr. Petite & Small Models	300 lbs.	Capri Model	325 lbs.
Medium, Large & Tall Models	375 lbs.	Imperial	375 lbs.
Dual Motor 26" & 28" Wide Models	450 lbs.	Relaxer	375 lbs.

In the event that the product does not conform to this warranty at any time while this warranty is in effect, Golden will correct the defect in conformity with the Consumer Limited Lifetime and Seven Year Warranty. THE LIMITED LIFETIME AND SEVEN YEAR WARRANTY SET FORTH ABOVE IS THE SOLE AND ENTIRE WARRANTY PERTAINING TO THE PRODUCT AND IS IN LIEU OF AND EXCLUDES ALL OTHER WARRANTIES OF ANY NATURE WHATSOEVER, WHETHER EXPRESS, IMPLIED, OR ARISING BY OPERATION OF LAW INCLUDING, BUT NOT LIMITED TO ANY IMPLIED WARRANTIES OF MERCHANTABILITY OR FITNESS FOR A PARTICULAR PURPOSE. THIS WARRANTY DOES NOT COVER OR PROVIDE FOR THE REIMBURSEMENT OR PAYMENT OF INCIDENTAL OR CONSEQUENTIAL DAMAGES. Some states do not allow this exclusion or limitation of incidental or consequential damages so the above limitation or exclusion may not apply to you.

GOLDEN shall not be liable for any incidental or consequential damages or for any other damage or loss not contained in this warranty.

This warranty gives you specific legal rights, and you may also have other rights which may vary from state to state.

The in-home service portion of this warranty is valid in all 50 states, the Canadian Provinces, and Puerto Rico.



PLACE
STAMP
HERE

GOLDEN TECHNOLOGIES
401 BRIDGE ST
OLD FORGE PA 18518-2323



GOLDEN LIFETIME LIMITED WARRANTY

Register your GOLDEN POWER LIFT CHAIR by filling out this warranty card within 30 days of purchase date and returning to GOLDEN TECHNOLOGIES. Be sure to keep copies of this registration so you have all the information to refer back in case you experience a problem with your chair.

Name _____

Address _____

City _____ State _____ Zip _____

Purchase Date _____ Model No. & Size _____

Reason for Purchase: Arthritis Parkinson's Heart Condition
Paralysis MS/MD Other _____

Age of User _____ Who Purchased Chair? _____

Dealer's Name and Address _____

Why Did You Choose The Golden Power Lift Chair?

Appearance Price Dealer Reputation

Additional Comments _____

Remember to read your owner's manual carefully before you operate your chair. If you need help or additional information please contact your dealer.

SERIAL NUMBER _____



Inquire about these fine mobility products also available from Golden Technologies



The Golden Companion Scooters are designed to give people the personal mobility they need to enjoy a more active and rewarding lifestyle and allow them to look great doing so. The Companion is without question the best value scooter available today.

Golden Companion Scooter
(Up to 350 lb. weight capacity)
GC-221 (*shown left*), GG-321, GC-421



This versatile power wheel chair is ideal for navigating all of life's tight spaces. It's quiet, sturdy and agile which makes the Alanté not only the smart choice for you but also your best value.

Golden *Alanté* Wheelchair
(300 lb. weight capacity)
GP-201 (*shown left*), GP-203
Also available in Front Wheel Drive



Golden Luxury adjustable beds are a great way to relieve lower back strain, encourage circulation and just plain relax! Available with nationally recognized name brand mattress featuring plush quilting and incredible comfort (twin, full, queen, king).

Golden Luxury Adjustable Bed
Available in three models -
Luxury through Economy
In four sizes

CAUTION

READ BEFORE OPERATING
FAILURE TO DO SO MAY VOID WARRANTY

Chair must be placed to allow free movement between:

BACK of CHAIR and WALL
FOOTREST and any object in FRONT of CHAIR

Keep children, pets and foreign objects from back of chair or underneath chair and from in front of footrest while operating chair.

Failure to do so may cause injury or damage to chair.