

# STOVAX

---



## *Riva MF Cassette*

MODELS: RV40/RV55/RV66/RV66AVC/RV76

## Instructions for Use, Installation and Servicing

For use in GB & IE (Great Britain and Republic of Ireland).



This appliance has been certified for use in countries other than those stated. To install this appliance in these countries, it is essential to obtain the translated instructions and in some cases the appliance will require modification. Contact Stovax for further information.

### **IMPORTANT**

This appliance will become hot whilst in operation, it is therefore recommended that a suitable guard should be used for the protection of young children, the elderly or infirm. Do not attempt to burn rubbish in this appliance.

Please read these Instructions carefully before installation or use.  
Keep them in a safe place for future reference and when servicing the fire.

The commissioning sheet found on page 3 of these instructions should be completed by the Installer.

## COVERING THE FOLLOWING MODELS:

RV40/RV55/RV66/RV66AVC/RV76

<b>APPLIANCE COMMISSIONING CHECKLIST</b>	<b>3</b>	<b>COMMISSIONING</b>	<b>24</b>
<b>USER INSTRUCTIONS</b>	<b>4</b>	<b>MAINTENANCE &amp; SERVICING</b>	<b>25</b>
General Points	4	Annual Service	25
Using the Appliance for the first time	6	Removal of Log Guard	26
Recommended Fuels	6	Removal of Fire Brick	26
Lighting the appliance	7	Removal of Baffle	26
Running the appliance	7	Removal of Riddling Mechanism	26
Burning Tips	8	Fitting a New Door Glass	26
Ash Removal	9	Fitting a New Door Seal	26
Over night burning	10	Adjusting Door Hinges	26
Over-Firing	10		
Chimney Fire	10	<b>BASIC SPARE PARTS LIST</b>	<b>27</b>
General Cleaning	10	<b>SERVICE RECORDS</b>	<b>29</b>
Cleaning Glass	10	<b>EC DECLARATION OF CONFORMITY</b>	<b>30</b>
Chimney Sweeping	10		
Care of Stove	11		
Seasonal Use	11		
Troubleshooting Tips	11		
<b>INSTALLATION INSTRUCTIONS</b>	<b>13</b>		
Technical Specifications	13		
Standard Features	13		
Packing List	13		
Dimensions	14		
<b>SITE REQUIREMENTS</b>	<b>15</b>		
Flue & Chimney	15		
Flue exit positions	16		
Hearth Dimensions	16		
Walls Next to Hearth	17		
<b>PRE-INSTALLATION</b>	<b>18</b>		
Ventilation	18		
Additional Ventilation	19		
<b>INSTALLATION</b>	<b>20</b>		
Legal Requirements	20		
Installing the Appliance	20		
Top Flue Installation	20		
Rear Flue Installation	21		
Removal of Log Guard	21		
Fitting & Removal of Fire Bricks	21		
Fitting & Removal of Baffles	22		
Fitting & Removal of Riddling Mechanism	22		
Adjusting Door Hinges	23		



This appliance has been approved by HETAS Ltd.

# APPLIANCE COMMISSIONING CHECKLIST

To assist us in any guarantee claim please complete the following information:-

## Dealer appliance was purchased from

Name: .....

Address: .....

.....

Telephone number: .....

## Essential Information - MUST be completed

Date installed: .....

Model Description: .....

Serial number: .....

## Installation Engineer

Company name: .....

Address: .....

.....

Telephone number: .....

## Commissioning Checks (to be completed and signed)

Is flue system correct for the appliance      YES       NO

Flue swept and soundness test complete      YES       NO

Smoke test completed on installed appliance      YES       NO

Spillage test completed      YES       NO

Use of appliance and operation of controls explained      YES       NO

Instruction book handed to customer      YES       NO

Signature: .....

Print name: .....

# USER INSTRUCTIONS

## 1. GENERAL POINTS

- 1.1 **Before use of this appliance please read these instructions fully.**
- 1.2 **All local regulations, including those referring to national and European Standards need to be complied with when installing the appliance.**
- 1.3 Only use for domestic heating in accordance with these operating instructions.
- 1.4 You must burn only approved fuels. Do not use with liquid fuels or as an incinerator.
- 1.5 Appliance surfaces become very hot when in use. Use a suitable fireguard if young children, elderly or infirm persons are present. Stovax offer firescreens, sparkguards and hearthgate systems for protection\*. Your Stovax dealer can advise you about these products.
- 1.6 Do not place photographs, TV's, paintings, porcelain or other combustible items on the wall or near the appliance. Exposure to hot temperatures will cause damage.
- 1.7 Extractor fans or cooker hoods must not be placed in the same room or space as this can cause appliance to emit fumes into the room.
- 1.8 Do not obstruct inside or outside ventilation required for the safe use of this appliance.
- 1.9 Do not make unauthorised changes to the appliance.
- 1.10 The chimney must be swept at least once a year. See Section 12
- 1.11 **Do not connect, or share, the same flue or chimney system with another appliance.**

### SERIAL NUMBER

- 1.12 This number is required when ordering spare parts or making warranty claims.

It is found as shown.

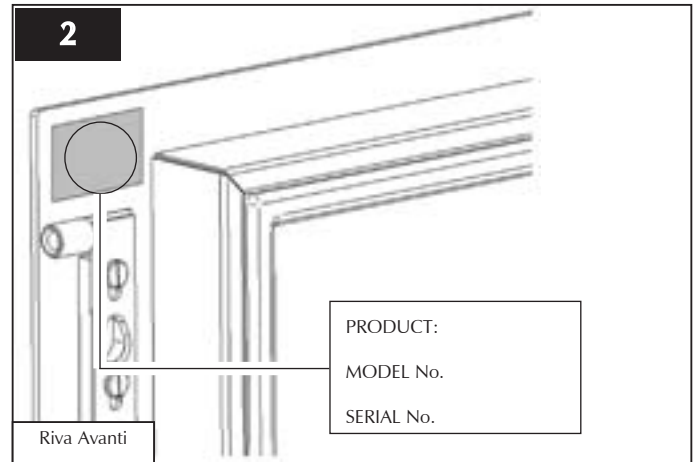
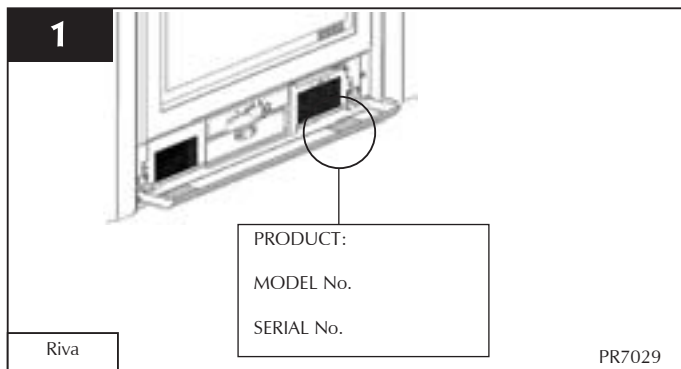

## AIR CONTROLS

### Cleanburn Technology and Convector Efficiency

Riva appliances incorporate the latest cleanburn technology with a unique 'Opti-Burn' setting in order to burn fuels with greater efficiency. See Diagram 3.

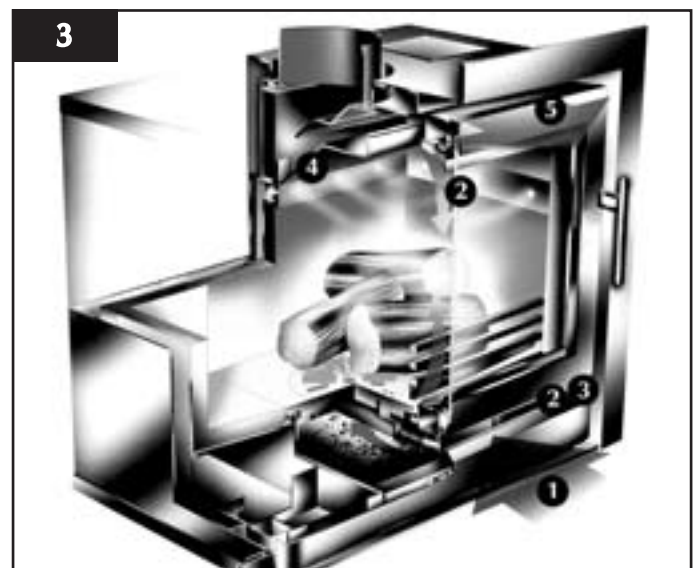

- 1) Primary Air - burns the fuel under the fuel bed. For use with solid fuel and initially with wood fires.
- 2) Airwash - air drawn over the window cleans the glass. The source of Primary Combustion air when burning wood.
- 3) Unique 'Opti-Burn' setting provides optimum efficiency and visual effect.

\*In the U.K: These products must conform to BS 6539, Fireguards for use with solid fuel appliances. If appliance is operating unattended they must conform to BS 3248

# USER INSTRUCTIONS

4) Clean burn - Secondary air is preheated through a heat exchanger to combust unburned hydrocarbons, providing a cleaner and more efficient burn.

5) Convected and radiant heat.

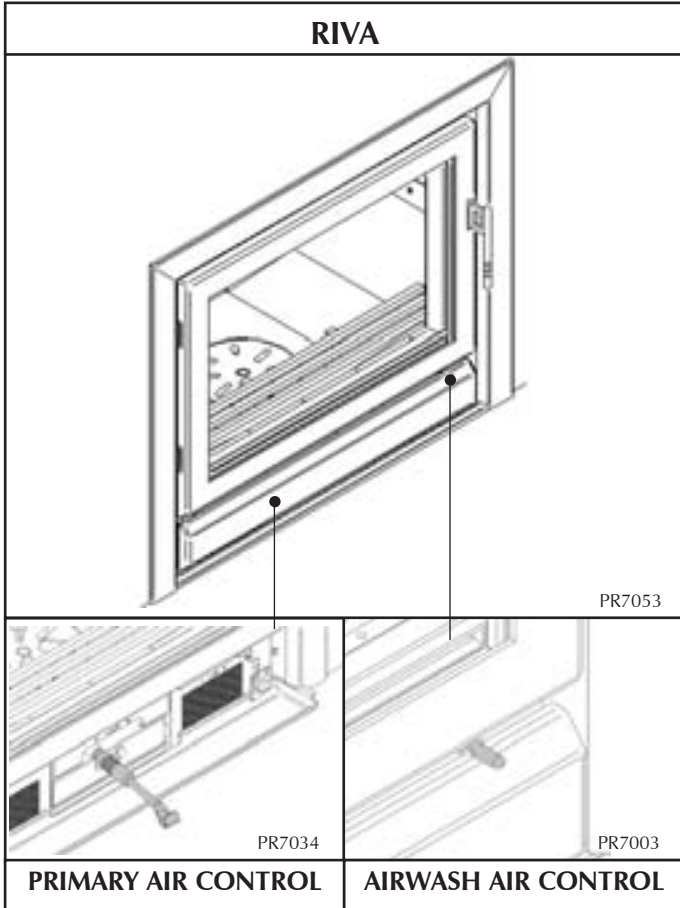

PR7053

PR7034

PR7003

Move air control as shown using the door tool.

This control has a pre-set "indent ball" stop in the closed position "opti-burn" setting. If the control is pushed past this point the airwash will be fully closed.

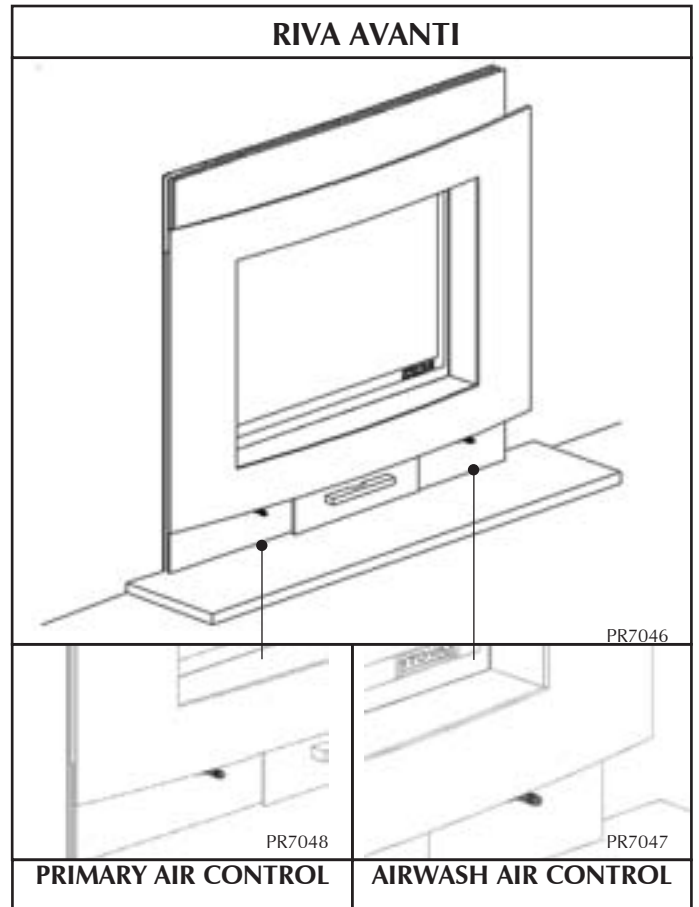

PR7046

PR7048

PR7047

This control has a pre-set "indent ball" stop in the closed position "opti-burn" setting. If the control is pushed past this point the airwash will be fully closed.

## DOOR HANDLE

### 1.13 Use a protected gloved hand to operate.

See Diagram

**DO NOT OPEN THE DOOR WITH BARE HANDS**

### 1.14 Riva 66

To remove the door handle:

- Lift the handle without rotating

### 1.15 To open the door:

- Pull the lower portion of the handle

To close the door:

- Hold the handle in the open position and push the door to the closed position
- Rotate the handle to the vertical position

# USER INSTRUCTIONS

## 1.16 Riva 66 Avanti

To open and close the door:

- Use the tool provided, see Diagram

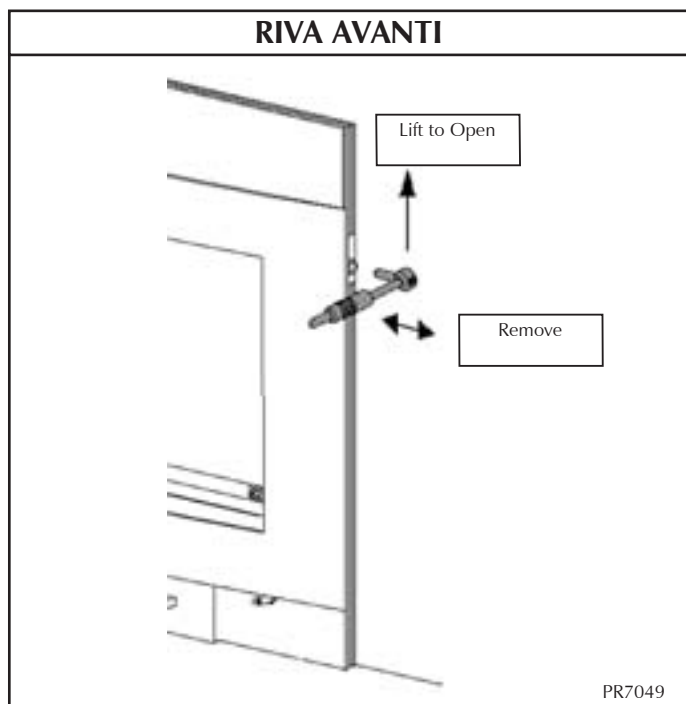
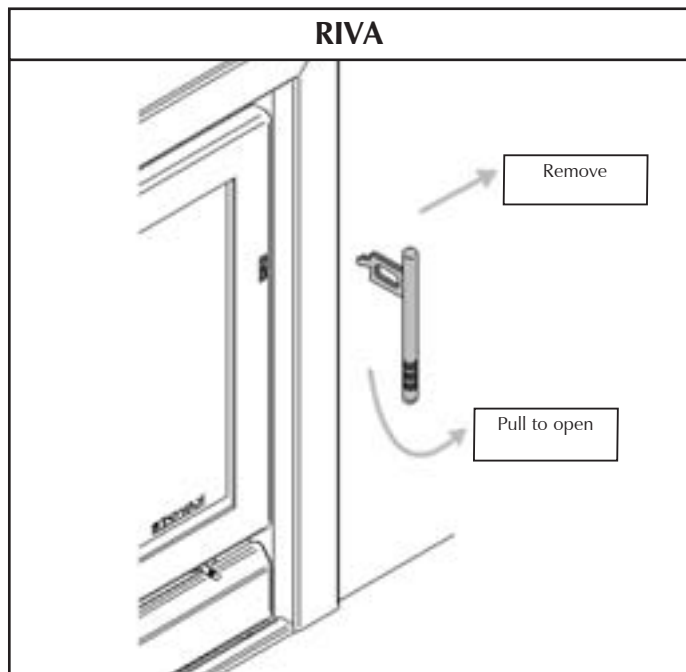

### WARNING

Properly installed, operated and maintained this appliance will not emit fumes into the room.

Occasional fumes from de-ashing and refuelling may occur.

**Persistent fume emission is potentially dangerous and must not be tolerated.**

If fume emission does persist:

- Open doors and windows to ventilate the room
  - Allow fire to burn out or safely dispose of fuel from the appliance
  - Leave the room
  - Check for chimney blockage and clean if required
  - Do not attempt to relight until the cause of the emission has been identified and corrected
- If necessary seek expert advice.

## 2. USING THE APPLIANCE FOR THE FIRST TIME

- 2.1 To allow the appliance to settle and fixing glues and paint to fully cure:
  - Operate the appliance at a low output for first few days
- 2.2 **Do not touch the paint during the first period of use.**
- 2.3 During this time the appliance may give off some unpleasant odours:
  - Keep the room well ventilated to avoid a build-up of fumes

## 3. RECOMMENDED FUELS

### 3.1 Wood Logs:

- Burn only seasoned timber with a moisture content of less than 20%

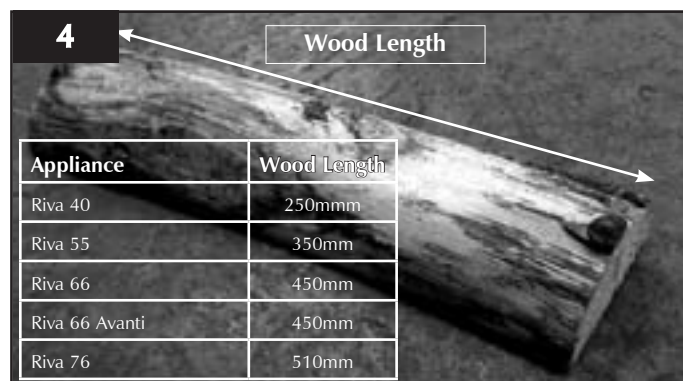

- Dry cut wood for 12 to 18 months before use
- Poor quality timber:
- Causes low combustion efficiency
  - Produces harmful condensation
  - Reduces effectiveness of the airwash and life of the appliance

**Do not burn construction timber, painted, impregnated / treated wood, manufactured board products or pallet wood.**

# USER INSTRUCTIONS

## 3.2 Solid fuel:

- Burn only anthracite or manufactured briquette smokeless fuels listed as suitable for use with closed heating appliances

**Do not burn bituminous coal, 'petro-coke' or other petroleum based fuels as this will invalidate the product guarantee.**

## 3.3 Fuel consumption.

As tested at nominal heat output to the requirements of EN 13240: 2001 for intermittent operation:

Description	Fuel Consumption	
	Kg/hour Wood	Kg/hour Briquette Smokeless fuel
Riva 40	1.6	0.8
Riva 55	2.4	1.2
Riva 66	2.6	1.2
Riva 66 Avanti	2.6	1.2
Riva 76	3.3	N/A

## 3.4 For advice on suitable solid fuels:\*

- Contact your local approved coal merchant

A number of factors can affect the performance of the appliance. See *Section 8* for details.

## 4. LIGHTING THE APPLIANCE

### 4.1 For best results:

- Set air controls, See Diagram

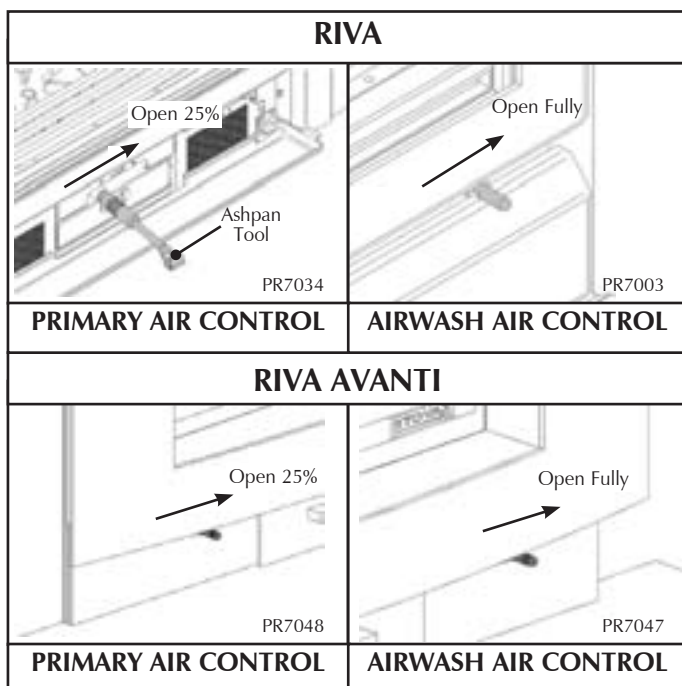

- Place firelighters or paper and dry kindling wood on the grate

- Light the paper or firelighters, See Diagram 6



- Leave the door slightly open as the fire establishes and the glass warms to avoid the build-up of condensation

- Add larger pieces of wood  
Too many logs may smother the fire.

**Do not load fuel above the log guard and the secondary combustion inlets at the back of the firebox.**

See Diagram 7

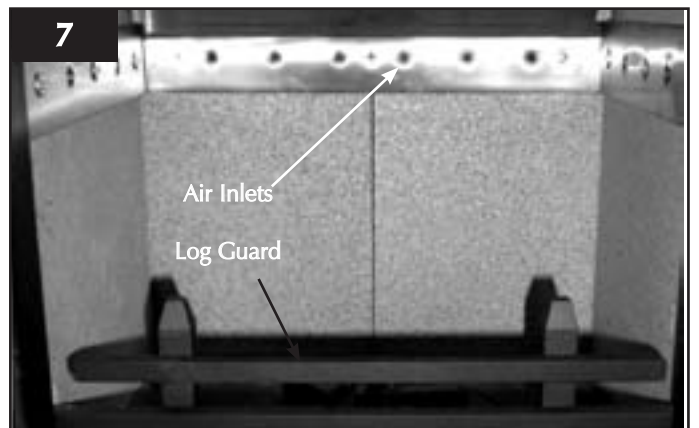

- Close the door

**Do not leave the door open as this could over-fire and damage the appliance.**

\*In the U.K:

- Ring the Solid Fuel Association advice line on 0845 601 4406 for details
- Visit their web site at [www.solidfuel.co.uk](http://www.solidfuel.co.uk)



# USER INSTRUCTIONS

## 5. RUNNING THE APPLIANCE

### 5.1 Burning Wood:

- Close the **Primary air control** (multi-fuel versions only) and use the **Airwash** to control the burn rate when appliance is at operating temperature, see Diagram

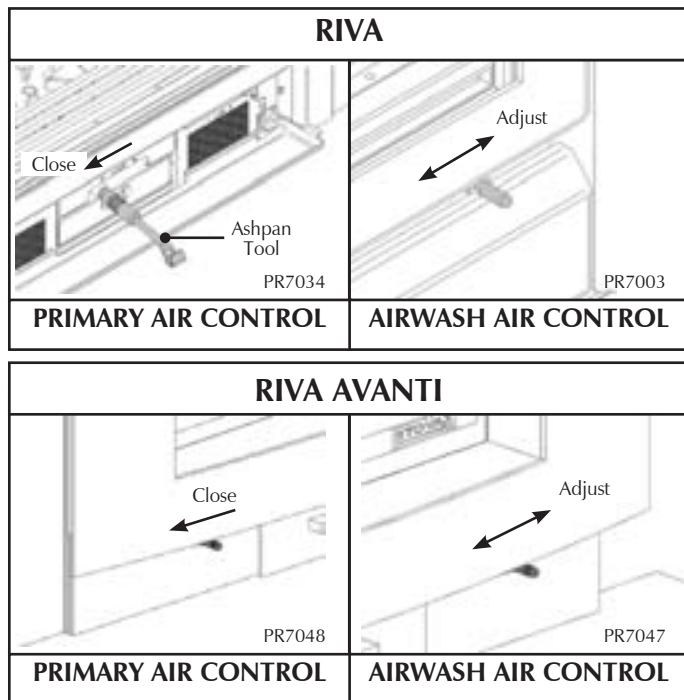

- Wood burns best on a bed of ash
  - Rake the embers evenly over the fire bed and open the **Airwash control** fully for a few minutes before re-fuelling
- 5.2 Burn new logs at high output for a few minutes before adjusting the **Airwash control**. Refuel little and often for clean, efficient burning.
- 5.3 Experience establishes settings to suit personal preferences.
- 5.4 Do not burn large amounts of fuel with the **Airwash control** closed for long periods of time. This reduces the glass cleaning effect and causes tars and creosotes to build-up in the appliance and flue system.
- 5.5 When in use, burning the appliance at high output for a short period also reduces tars and creosote.

### 5.6 Burning Solid fuel (Not applicable for Riva 76):

- Set air controls, See Diagram

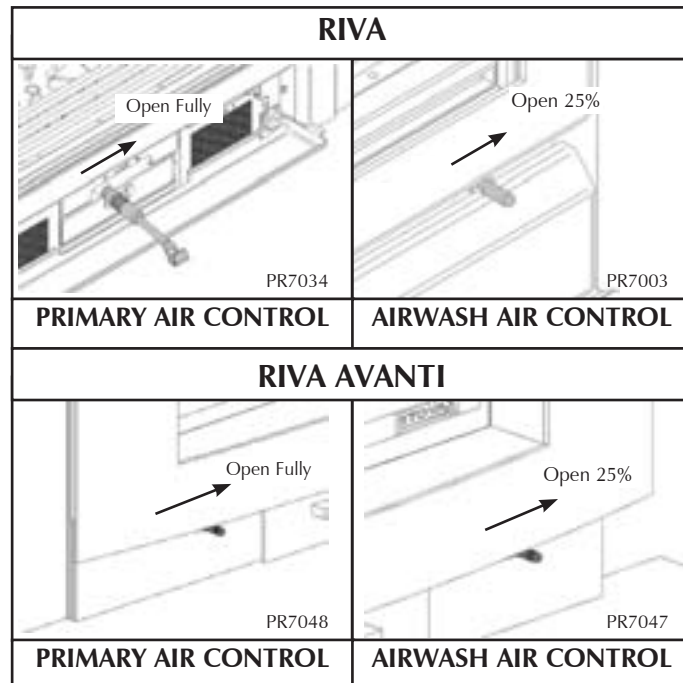

- 5.7 When the fire becomes established reduce the **Airwash air control** to approximately **25%** open and control the burn rate using the **Primary air control only**.
- 5.8 De-ash the fire bed before re-fuelling, see *Ash Removal, Section 7*.
- Open the **Primary air control** fully to establish a glowing bed before adding new fuel
  - Burn new fuel at high output for a few minutes before adjusting the **Primary air control** to the desired setting
  - Refuel little and often for clean, efficient burning.
- 5.9 Experience establishes control settings to suit personal preferences
- 5.10 Do not burn large amounts of fuel with the **Primary Air Control** on low settings for long periods of time. This reduces the glass cleaning effect of the air wash and causes tars and creosotes to build-up in the appliance and flue system.
- 5.11 When in use, burning the appliance at high output for a short period also reduces tars and creosote.
- 5.12 **You must burn only anthracite or smokeless fuels suitable for use in closed appliances.**
- 5.13 **Do not burn bituminous coal, 'petro-coke' or other petroleum based fuels as this invalidates the product guarantee.**

**Do not load fuel above the log guard and the secondary combustion inlets at the back of the firebox.**  
See Diagram 7



# USER INSTRUCTIONS

## 6. BURNING TIPS

### 6.1 Fuel Quality (Wood)

Use wood with a moisture content of less than 20%. Seasoned logs have the bark beginning to lift and peel away and cracks radiating from the centre. They feel lighter than fresh cut wood of a similar size and sound hollow when struck against each other. Logs should not feel damp or have moss and fungal growths.

Symptoms related to wet wood:

- Difficulty starting and keeping a fire burning well
- Smoke and small flames
- Dirty glass and/or firebricks
- Rapid creosote build-up in the chimney
- Low heat output
- Short burn times, excessive fuel consumption and blue/grey smoke from the chimney

- Burn at high output at high output for a short period each day to avoid large build-ups of tars and creosote within the appliance and the flue system
- Use Stovax Protector chimney cleaner to reduce this problem

### 6.2 Fuel Quality (Solid Fuel)

- Use recommended solid fuels approved for use with closed appliances.

Symptoms related to unsuitable fuels include:

- Difficulty starting and keeping a fire burning well
- Smoke and small flames
- Dirty glass and/or fire bricks
- Short life span for grate, baffles and internal firebricks
- Permanent staining of glass

### 6.3 Air inlets puffing smoke

Combustion gases build up in the firebox and ignite as small explosions, causing smoke to puff out of the air inlets and other openings. This occurs if the air controls are shut soon after adding new fuel to a very hot fire. Stop by opening the air controls to increase combustion air and burning rate.

### 6.4 Flue Draught

The chimney has two main functions:

- 1) To safely remove the smoke, gases and fumes from the house.
  - 2) To provide a sufficient amount of draught (suction) in the appliance ensuring the fire keeps burning.
- Draught is caused by the rising hot air in the chimney when the appliance is lit.

Symptoms of poor performance related to flue draught include:

- Excessive fuel consumption (high flue draught)
- Poor burning control, overheating (high flue draught)
- Wind noise from air controls (high flue draught)

- Difficulty getting a fire going and keeping it burning well (low flue draught)
- Low heat output (low flue draught)
- Smoke entering room when doors opened (low flue draught)

The construction, position, size and height of the chimney all affect the performance of the flue draught.

Other factors effecting the flue draught include:

- Trees or other buildings nearby causing turbulence
- High and gusty winds
- Outside temperature
- Outside weather conditions
- Incorrect additional ventilation to building
- Blocked flue / chimney

For advice on the correction of persistent flue problems consult a qualified solid fuel heating engineer before continuing to use the appliance.

### 6.5 Weather conditions

The weather conditions outside the building can effect the burning performance of the appliance. These could include:

Weather Conditions	Problem	Effect
Windy days	Buildings/Obstacles cause turbulent air around chimney.	Smoky Appliance
Calm days	Oversized Chimney.	Smoky Appliance
Damp / Rainy days	Flue temperature not hot enough. Rain water inside chimney.	Lighting and burning problems

To reduce these problems:

- Use good quality kindling wood to start the fire
- Burn initially at a high temperature for a short period
- Fit a rain cowl to the chimney

Your installer should advise you on possible solutions.

If the appliance emits smoke into the room continuously:

- Close the air controls and allow the appliance to go out
- Ventilate the room to clear the fumes
- Leave the room

**Do not re-light the appliance until the problem is solved.**

# USER INSTRUCTIONS

## 7. ASH REMOVAL

### 7.1 All fuels:

- Open Ash pan Cover (Riva 66 only), See Diagram 8

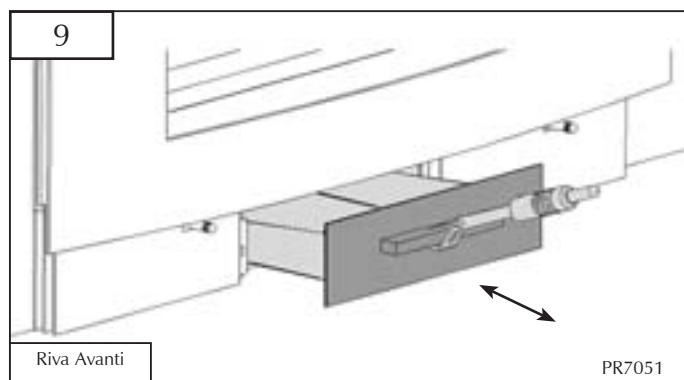
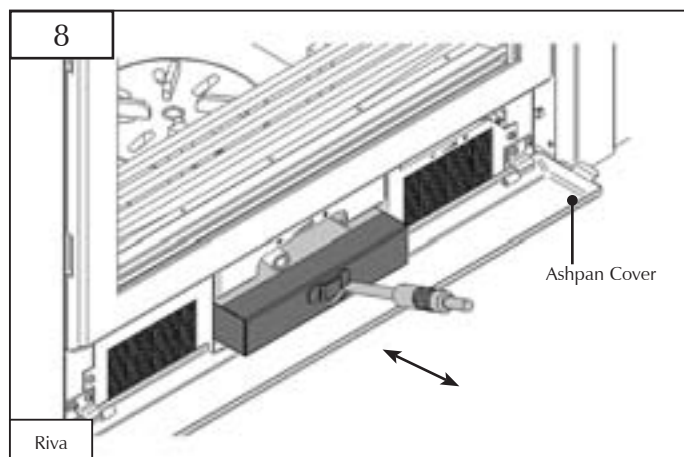

- Remove Ashpan carefully. Heat can remain long after use
- Use gloves, or place the ash into a Stovax Ash Caddy (Stovax Part No. 4227)
- Remove ash at least once every week
- Do not place hot ash in a bin made from plastic or any other combustible material.

## 8. OVER NIGHT BURNING

### 8.1 It is possible to get the appliance to burn over night. In order to do this:

- De-ash prior to final refuelling
- Set air controls to low combustion settings  
This will blacken the glass over night but it will clear when operated at high output for a short period.
- Use smokeless fuel or small, thick logs depending on fuel desired

## 9. OVER-FIRING

9.1 Do not over-fill with fuel or use at maximum output for long periods or over-firing can occur. If the flue pipe, flue collar or top plate glow red the appliance is over-firing:

- Close the air controls to reduce the output

9.2 Over-firing can cause permanent damage to the appliance.

## 10. CHIMNEY FIRE

10.1 If a chimney fire occurs:

- Shut all air controls immediately
- Evacuate the building
- Call the fire brigade
- Do not re-enter the building until it is confirmed safe

10.2 **Do not use the appliance after a chimney fire until:**

- It has been inspected by a registered installer, confirming the appliance is safe to use\***
- The chimney system inspected and swept by a chimney sweep, confirming the system is structurally sound and free from obstruction before re-use.\*\*
- It is repaired as required before re-use.** Use only genuine Stovax replacement parts to keep your appliance in safe and efficient working order.

## 11. GENERAL CLEANING

11.1 **Allow appliance to cool thoroughly to avoid risk of burns:**

- Clean regularly, according to the level of use
  - Give attention to the baffle system, flue ways and removing ash
- Regular cleaning and maintenance will help give many years of safe use.

To refresh painted finishes use Stovax Thermolac paint.

- Clean finishes using warm soapy water and a soft clean cloth
- Do not use aerosol sprays near an operating appliance

Wipe dry with a soft clean cloth before re-lighting. Do not

In the U.K:

\* registered with HETAS (GB only)/INFO (Republic of Ireland only)  
\*\*This should be done by a NACS registered (UK only)/INFO registered (Eire only) chimney sweep, who will issue you with a certificate.

# USER INSTRUCTIONS

leave unit without drying, as this may cause rust.

**Do not use abrasive cleaner or cleaning pads to clean enamel finishes.**

## 12. CLEANING GLASS

- Keep the glass clean with correct use of the Airwash system and good quality fuel

Sometimes additional cleaning may be required.

12.1 This can be done as follows:

- Allow appliance to cool fully
- Do not clean hot glass.
- Use a soft cloth and Stovax Glass Cleaner

12.2 Before re-lighting the appliance:

- Dry the glass fully

12.3 **Do not use abrasive cleaner or cleaning pads.**

Do not allow glass cleaner to come in contact with any painted or metal surface as it can damage the finish.

## 13. CHIMNEY SWEEPING

13.1 To maintain safe and efficient use of the appliance the chimney/flue must be inspected and swept at least once a year by a qualified chimney sweep.\*\*

If the appliance is used continuously throughout the year or it is used to burn wood or smokeless fuel, more frequent sweeping is recommended.

The best time to have the chimney swept is at the start of the heating season.

The above applies even if burning smokeless fuels.

13.2 The chimney, any connecting flue pipe and the appliance flue ways if incorporated, must be regularly cleaned.

13.3 Ensure adequate access to cleaning doors where it is not possible to sweep through the chimney.

13.4 If the appliance is believed to have previously served an open fire the chimney must be swept a second time within a month of regular use after installation.

In the U.K:

\* registered with HETAS (GB only)/INFO (Republic of Ireland only)

\*\*This should be done by a NACS registered (UK only)/ INFO registered (Eire only) chimney sweep, who will issue you with a certificate.

## 14. CARE OF STOVE

Stovax has a range of cleaning and maintenance products and accessories to keep your appliance in good working condition. Your Stovax retailer can provide full details but here is a brief list of useful items:

Product Code	Description
3047	Extra long matches
5039	Gas lighter
4052	Log basket
3048	Wood sling - for easy carrying of logs
3016	Log tongs
4027	Extra long protective gloves
5038	Hearthgate - 5 section (for areas 1780x610mm)
5044	Hearthgate - 7 section (for areas 1780x405mm)
4227	Ash caddy - 382x102x306mm
4228	Ash caddy - 446x102x306mm
4229	Ash caddy - 382x102x459mm
4230	Ash caddy - 637x127x408mm
4231	Ash caddy - 306x178x459mm
2091	Ashclean vacuum cleaner attachment
4232	Steel brush

Your retailer can provide genuine spare parts such as replacement glass, door sealing rope and fire bricks when required. An annual service by a competent engineer is recommended to keep your appliance in best possible condition.



# USER INSTRUCTIONS

## 15. SEASONAL USE

- 15.1 Clean and service the appliance if it is not used during the warmer periods of the year as detailed in the *Maintenance and Servicing* section
- 15.2 Set the air controls 50% open to keep the appliance ventilated and stop the build-up of any moisture inside.
- 15.3 Before re-lighting the appliance:
  - Remove the baffles
  - Clear any debris that may have accumulated
  - Check the flue is clear of any blockages

## 16. TROUBLESHOOTING TIPS

### 16.1 Stove glass blackening:

This has four possible causes:

1. **Incorrect use of airwash** – See Sections 1, 4 and 5 for the correct use of the air controls.
2. **Burning unseasoned wood** – See Section 3 to identify when wood is ready for burning.
3. **Stove operated at too low a temperature** - good working temperature is 300-500° F (120 – 250° C). A stove pipe thermometer can identify this problem (Stovax part no 3046)
  - Burn with the airwash control fully open for approximately 20 minutes to cure thisThe problem may be caused by damping your appliance down overnight.
4. **Problems with the flue** – in particular insufficient air pull. If the flue is not working efficiently the glass can blacken. A flue which has too much downdraft may be too short or needs lining or has too many bends. This can also cause blackening of your stove glass. Contact the installer or a flue specialist for advice.

### 16.2 Riddling mechanism jamming:

This occurs when fine ash builds up under the riddling bars preventing movement. To prevent this:

- Follow a regular cleaning routine for the inside of your appliance
- Lift out the riddling mechanism and remove all ash
- Replace riddling mechanism when cleaning is complete

### 16.3 Glass cracking:

Do not over tighten the screws on the glass clips when replacing the glass as this causes stress and the intense temperature changes can cause the glass to crack. For replacement glass contact your local Stovax dealer.

### 16.4 Appliance is producing tar:

This is identified by:

- A very strong pungent smell shortly after the appliance is lit and heats up

- Glass blackening
- Thick, brown and sticky tar oozes from the pipe joints

This is caused by burning damp wood and burning your appliance at too low a temperature;

- Use well seasoned wood and operate the appliance in the ideal temperature range

Tar is a major cause of chimney fires - if you experience problems with tar build up consult a chimney sweep before continued use of your appliance.

**Ideal working temperature** range is 130°C and 240°C (270°F – 465°F). Failing to close down the primary air control once the appliance has heated up to this range may cause the appliance to over-fire and to exceed the ideal temperature range. Over-firing can cause permanent damage to the appliance and invalidates your warranty.

# TECHNICAL SPECIFICATION

## RIVA MF CASSETTE

Model			Riva 40	Riva 55	Riva 66	Riva 66 Avanti	Riva 76
Riva 40-RV 40/RV40B							
Riva 55-RV 55/RV55B							
Riva 66-RV 66/RV66B							
Riva 66 Avanti-RV66AVC							
Riva 76/RV76							
Nominal Heat Output	Wood	kW	4.9	8	8	8	9.5
	Solid Fuel	kW	4.9	8	8	8	N/A
Flue Draught at Nominal Heat	All Fuels	mm	1.5	1.5	1.5	1.5	1.5
		inch Wg	0.05	0.05	0.05	0.05	0.05
Flue Gas Mass Flow	Wood	g/s	5.8	8.3	7.4	7.4	10.8
	Solid Fuel	g/s	5.2	9.9	8.1	8.1	N/A
Flue Gas Temperature at Spigot/Socket	Wood	°C	444	492	388	388	406
	Solid Fuel	°C	444	492	388	388	N/A
Flue Outlet Size		mm	128	128	150	150	150
		inch	5	5	6	6	6

Weight		kg	70	90	101	121	125
--------	--	----	----	----	-----	-----	-----

Recommended Fuel	Wood	Seasoned wood (less than 20% moisture content)
	Solid Fuel	Briquette smokeless fuel suitable for closed appliances (Ancit - Phurnacite - Taybrite - Homefire ovals)

As tested to the requirements of EN 13229:2001 for intermittent operation

### STANDARD FEATURES

- Primary air (under grate air for full multifuel use)
- Airwash (for woodburning/ clean glass)
- Pre-set secondary air control (to ensure complete burning of flue gases)
- Riddling grate system for clean de-ashing
- Stainless steel ashpan
- Removable door handle
- Interchangeable trim / frame options
- Pre-drilled convection air duct connection points (not Riva 40)
- Optional fan convection kit - must be fitted before installation only (not Riva 40)
- Spacer frame kit - to suit 350mm deep opening (Riva 66 and 76 only)

### PACKING LIST

- User Instructions
- Installer Instructions
- Guarantee card
- Accessory catalogue
- Pair leather stove gloves
- Fixing kit (2 x rawl plugs + 2 x coach screws)
- 2.5mm A/F Hex socket key
- 4mm A/F Hex Socket Key
- 5mm A/F Hex Socket Key
- Door tool
- Riddling tool

# TECHNICAL SPECIFICATION

## RIVA DIMENSIONS

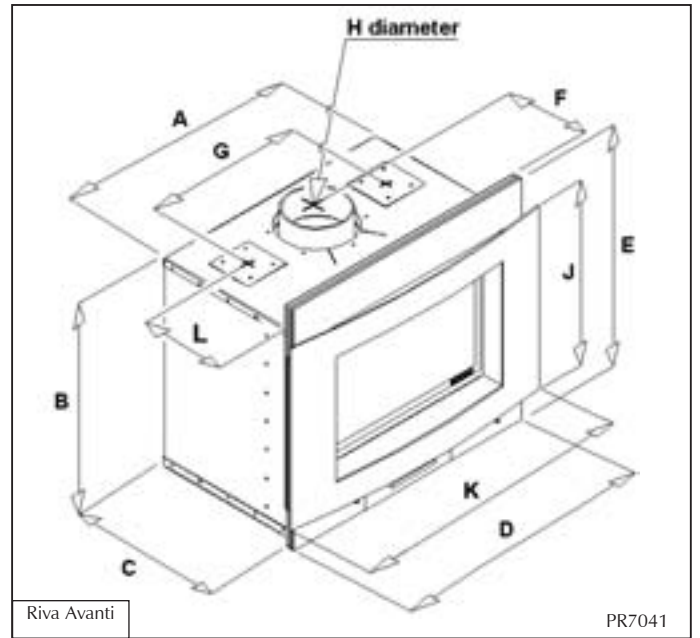
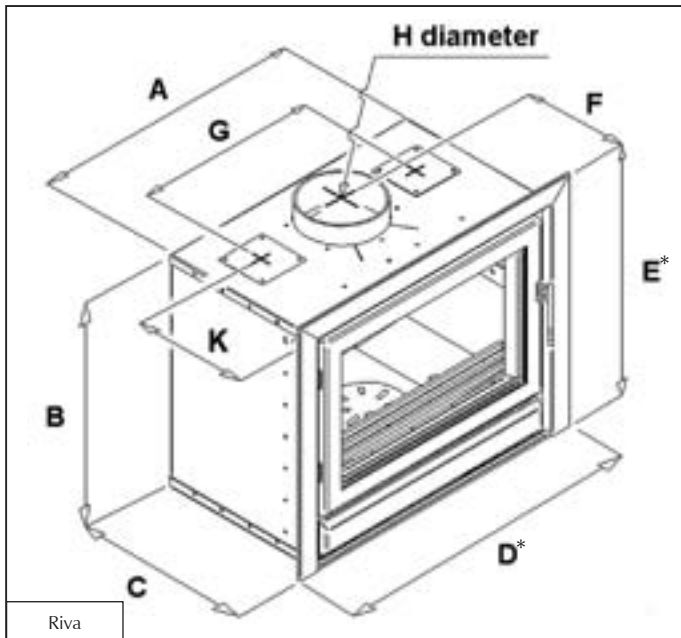

	Riva 40 RV40	Riva 55 RV55	Riva 66 RV66	Riva 66 Avanti RV66 AVC	Riva 76 RV76
A	400mm	540mm	650mm	650mm	760mm
B	550mm	660mm	550mm	550mm	630mm
C	350mm	350mm	395mm	395mm	395mm
D	492mm	632mm	742mm	694mm	862mm
E	599mm	709mm	599mm	636mm	678mm
F	234mm	234mm	248mm	248mm	248mm
G	N/A	360mm	420mm	420mm	540mm
H	128mm	128mm	153mm	153mm	153mm
J	N/A	N/A	N/A	480mm	N/A
K	N/A	N/A	N/A	755mm	N/A
L	N/A	234mm	248mm	248mm	208mm

All dimensions in mm. (25.4 mm = 1")



# SITE REQUIREMENTS

## 1. FLUE OR CHIMNEY

- 1.1 The flue or chimney system must be in good condition. It must be inspected by a competent person and passed for use with the appliance before installation

**Products of combustion entering the room can cause serious health risks.**

- 1.2 You must check the following:

— The construction of the masonry chimneys, flue block chimneys and connecting flue pipe system must meet the requirements of the Building Regulations†

— A flexible flue liner system can be used if certified for use with solid fuel systems and installation complies with manufacturer's instructions and Building Regulations. The flue liner must be replaced when an appliance is replaced unless proven to be recently installed and in good condition.

— If it is necessary to fit a register plate it must conform to the Building Regulations†

— The minimum height of the flue or chimney must be 4.5m from the hearth to the top of the flue, with no horizontal sections, a maximum of 4 bends with angles of less than 45 degrees

— Ensure the connecting flue pipe it kept a suitable distance from any combustible material and does not form part of the supporting structure of the building

— Make provision to remove the appliance without the need to dismantle the chimney

— Any existing flue must be confirmed as suitable for the new intended use as defined in the Building Regulations

— The flue or chimney systems must be inspected and swept to confirm the system is structurally sound and free from obstructions\*\*

— If the chimney is believe to have previously served an open fire the chimney must be swept a second time within a month of regular use after installation to clear any soots falls that may occurred due to difference in combustion levels.

— The flue exit from the building must comply with local building control rules.†

— Do not connect or share the flue or chimney system with another heating appliance

- 1.3 Do not connect to systems containing large voids or over 230mm square.

- 1.4 You must provide suitable access to enable the collection and removal of debris.

- 1.5 You must be able to sweep and inspect the flue when the appliance is installed.

- 1.6 You must check the flue draught with all windows and doors closed and any extraction fans in this or adjoining rooms running at maximum speed. (See next section for additional ventilation requirements)

**Max. Draught = 2.0mm Wg**

**Min. Draught = 1.0mm Wg**

### In the U.K:

\*BS 6461: Part 1, and the requirements of Building Regulations

\*\*This should be done by a NACS registered (UK only)/ INFO registered (Eire only) chimney sweep, who will issue you with a certificate.

† Building Regulations Document J

### Flue Plate:

Where a hearth, fireplace, flue or chimney is provided or extended (including cases where a flue is provided as part of refurbishment work), information essential to the correct appliance and use of these should be permanently posted in the building, to meet Requirement J4 of the Building Regulations (England and Wales), F3.12 (Scotland).

† Building Regulations Document J

### Additional:

A new factory made system that complies to EN 1856; Part 1 can be used providing installation is to the requirements of:  
i) BS 7566 Parts 1 -4  
ii) the manufacturer's instructions  
iii) Building Regulations.

For a guide containing information on Chimneys and Flues contact:

The British Flue & Chimney Manufacturers' Association,  
FETA  
2 Waltham Court  
Milley Lane  
Hare Hatch  
Reading  
Berkshire RG10 9TH

Tel: 0118 9403416

e-mail: [info@feta.co.uk](mailto:info@feta.co.uk)

# SITE REQUIREMENTS

## 1. FLUE OUTLET POSITIONS

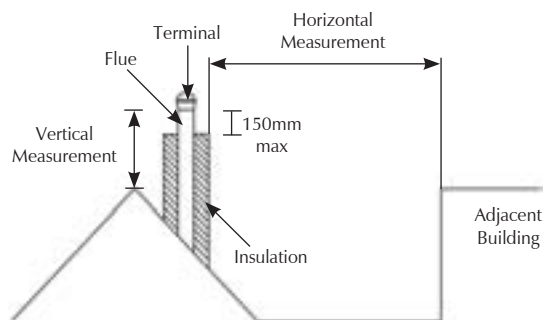
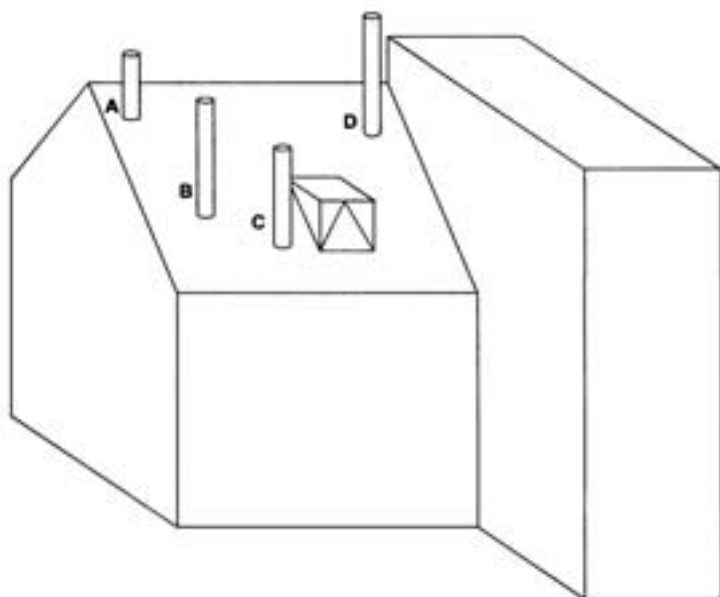

The vertical measurement is the lowest from either the point of discharge or 150mm above insulation.

	Position On Roof	Minimum Clearances
A	On ridge or within 600mm	600mm above ridge
B	Elsewhere on roof	2300mm horizontally from roof surface and: a) 1000mm above highest point of flue exit from roof or b) as high as the ridge
C	On pitched, within 2300mm horizontally to openable window, dormer	1000mm above top of opening
D	Within 2300mm of another building	600mm above top of building

**IMPORTANT:** Seek specialist advice if installing in a dwelling with a thatched roof

## 2. MINIMUM DIMENSIONS - HEARTH

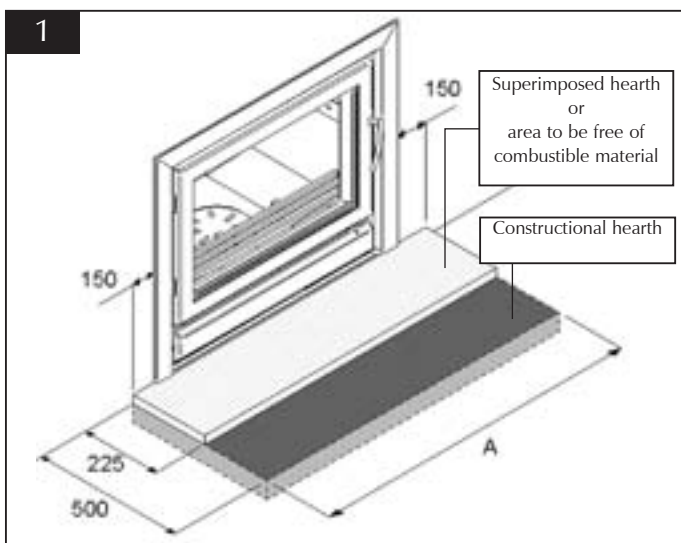

- 2.1 The appliance must stand on a non-combustible constructional hearth which is at least 125mm thick with the minimum dimensions as shown in diagram. If it is to be fitted in a raised setting consideration may need to be given to extending the depth of the hearth to safely containing any falling logs or embers.
- 2.2 The building must have a suitable load-bearing capacity for the hearth and appliance.
  - Consult a structural engineer for advice before proceeding
- 2.3 When fitting into an existing hearth check:
  - That the appliance complies with current construction regulations and is at least the minimum sizes shown
- 2.4 If there is no existing fireplace or chimney it is possible to construct a suitable non-combustible housing and hearth setting. The flue must be installed in accordance with all local and national regulations and current rules in force .
  - Check if adding a new chimney to your property requires planning permission
- 2.5 Some houses are built using a timber frame construction with high levels of thermal insulation. Isolate the appliance from combustible materials, and provide sufficient ventilation to maintain the heating efficiency.

	Riva 40 RV40	Riva 55 RV55	Riva 66 RV66	Riva 66 Avanti RV66 AVC	Riva 76 RV76
A	792mm	932mm	1042mm	1042mm	1162mm

# SITE REQUIREMENTS

## 4. MINIMUM BUILDERS OPENING

To make installation easier make the opening larger than the minimum requirements where possible.

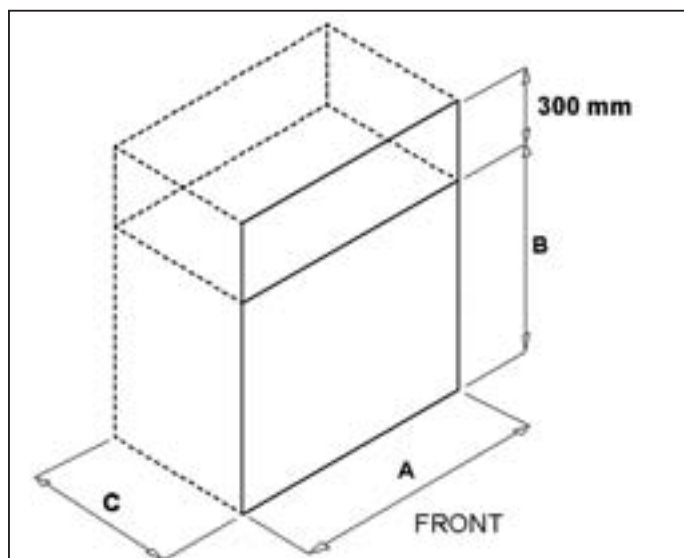

### Riva 55/66/76 only

If optional convection air ducts are to be used, increase the opening height by 300mm to enable connection to be made before final completion of building work.

### Riva 66/76 only

Dimension C may be reduced to 355mm when using the spacer frame kit. Consideration must be given for the clearance of 20mm between the flue pipe and lintel/inside chimney breast

## 5. RIVA MF CASSETTE

	Riva 40 RV40	Riva 55 RV55	Riva 66 RV66	Riva 66 Avanti RV66 AVC	Riva 76 RV76
A	410mm	550mm	660mm	660mm	770mm
B	560mm	670mm	560mm	560mm	640mm
C†	360mm	360mm	405mm*	405mm*	405mm*

\* Riva 66/76 only

† Dimension C may be reduced to 355mm when using the spacer frame kit.

For information on frames available, please contact your local retailer or call Stovax Ltd on 01392 474011

Consideration must be given for the clearance of 20mm between the flue pipe and lintel/inside chimney breast.

## 6. BUILDERS OPENING

Many fireplace openings have a supporting lintel. Remove the covering plaster to identify its position before starting any constructive work. Do not remove constructional lintels without making provision to support the remaining structure of the building. The appliance must not form any part of the supporting structure.

- 6.1 The chimney/flue must have a sealed connection to the appliance flue spigot.
- 6.2 The structure of the builders opening will reach high temperatures. Use insulating blockwork to reduce the heat transfer to the external walls, in particular the area of the chimney breast above the opening.
- 6.3 **Take care when finishing the chimney breast and surrounding area. The conducted and convected heat emitted by the appliance could be high enough to crack normal plaster. Use a high temperature plaster, or face the area with a suitable high temperature plasterboard. New plaster should be fully dried before the appliance is used, or cracking could occur.**

### Riva 40 only

It is possible to fit the Riva 40 into an existing, traditional, 16" fireplace opening following the removal of any existing milner fireback. Following the removal of the fireback and any flaunching above, the builders opening should be checked and made good to the dimensions shown in the table. Care should be taken to ensure the existing chimney is in good condition and that it is possible to make the required sealed fluepipe connections to this when the Riva 40 is installed.

**If you are in any doubt about your ability to produce a safe opening contact your Stovax dealer for professional advice.\***

### Riva 55/66/76 only

Should you wish to connect air ducting to the convection system, provision should be made to increase the opening height by an additional 300mm. This will allow the access needed to fit the duct pipes after connecting the flue system.

\* In the U.K

Additional information covering the installation the appliance may be found in the following British Standards:- BS6461, BS6999, BS8303.

# SITE REQUIREMENTS

## 7. FIRE SURROUND CLEARANCES

If the appliance is to be fitted with a fire surround, use the **minimum** clearances, see Diagram, between any point of the appliance and any combustible material. Stovax produce a selection of surrounds and details can be obtained from your local supplier.

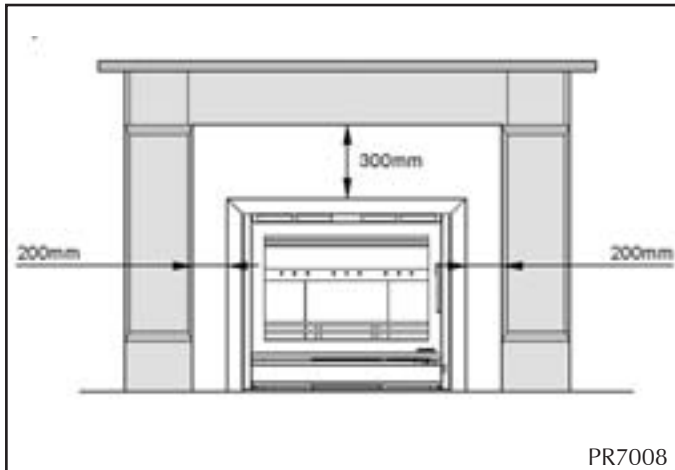

- 7.1 We recommend you obtain expert advice before proceeding with work of this nature.
- 7.2 Some finishes may discolour with heat and some lower quality products may distort, or crack, when in use.

**If stone / granite / marble or any other natural material is used to construct the fire surround, or any part of it, provision should be made for expansion and movement of the parts due to heating and cooling.**

**If you are in any doubt about the installation requirements, or suitability of fire surrounds contact your Stovax dealer.**

- 7.3 All fire surrounds should be suitable for use with solid fuel heating products.

# PRE-INSTALLATION CHECKS

## 1. VENTILATION

Model			Riva 40	Riva 55	Riva 66	Riva 66 Avanti	Riva 76
Riva 40-RV 40/RV40B							
Riva 55-RV 55/RV55B							
Riva 66-RV 66/RV66B							
Riva 66 Avanti-RV66 AVC							
Riva 66-RV76/RV76B							
Flue/Chimney Size	Without liner system (round) minimum dimension (dia.)	mm	150	150	150	150	150
		inch	6	6	6	6	6
	Without liner system (square) minimum dimension	mm	135	135	135	135	135
		inch	5½	5½	5½	5½	5½
	Liner or factory made system (dia.) <small>installed in accordance with manufacturers instructions</small>	mm	†150	150	150	150	150
		inch	†6	6	6	6	6
Do not connect to systems containing large voids or over 9" (230mm) square/round							
Flue/Chimney minimum height*	All Products	m	4.5	4.5	4.5	4.5	4.5
		feet	13	13	13	13	13
* When measured from the top of the stove to the top of the flue, with no horizontal sections and a maximum of 4 bends with angles of less than 45°							
†May be 125mm (5") if only burning low volatiles (smokeless) fuels approved for use in Smoke Control Areas. See web site <a href="http://uksmokecontrolareas.co.uk">http://uksmokecontrolareas.co.uk</a> for more information about approved fuels.							

- 1.1 This appliance requires ventilation to supply combustion air. Any room containing the appliance must have a permanent air vent opening with a total free area of at least 550mm<sup>2</sup> per kW of appliance rated output above 5kW.
- 1.2 Increase air supply provisions where a room contains multiple appliances.
- 1.3 If vents open into adjoining rooms or spaces there must be an air vent of at least the same size direct to the outside.
- 1.4 Permanent air vents should be non-adjustable and positioned where they are unlikely to become blocked.
- 1.5 Site the vents where cold draught is unlikely to cause discomfort. This can be avoided by placing vents near ceilings or close to the appliance, see Diagram opposite.

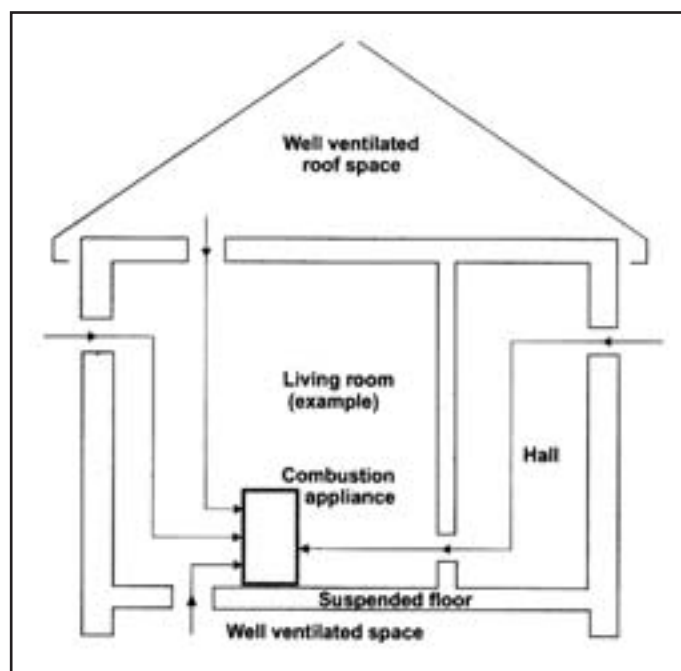

# PRE-INSTALLATION CHECKS

## 2. ADDITIONAL VENTILATION

- 2.1 Additional ventilation is required to comply with the requirements of the Building Regulations. This must be provided using a permanently open air vent, of the size listed, which is positioned so that it is not liable to be blocked both inside and outside the building.
- 2.2 Extractor fans or cooker hoods must not be placed in the same room or space as this can cause the appliance to emit fumes into the room.
- 2.3 **If any of these checks reveal problems do not proceed with the fitting of the appliance until they have been rectified.**

Model		Riva 40	Riva 55	Riva 66	Riva 66 Avanti	Riva 76
Riva 40-RV 40/RV40B						
Riva 55-RV 55/RV55B						
Riva 66-RV 66/RV66B						
Riva 66 Avanti-RV66 AVC						
Riva 66-RV76/RV76B						
Additional Ventilation	mm <sup>2</sup>	NONE	1650mm <sup>2</sup>	1650mm <sup>2</sup>	1650mm <sup>2</sup>	2475mm <sup>2</sup>
	cm <sup>2</sup>	NONE	16.5cm <sup>2</sup>	16.5cm <sup>2</sup>	16.5cm <sup>2</sup>	24.75cm <sup>2</sup>
	in <sup>2</sup>	NONE	2.56in <sup>2</sup>	2.56in <sup>2</sup>	2.56in <sup>2</sup>	4.00in <sup>2</sup>



# INSTALLATION INSTRUCTIONS

## LEGAL REQUIREMENTS

**Before installation of this product please read these instructions fully.**

It is very important to understand the requirements of the national Building Regulations\* and standards\*\*, along with any local regulations and working practices that may apply. Should any conflict occur between these instructions and these regulations then the regulations must apply.

Your local Building Control Office can advise regarding the requirements of the regulations.

The appliance must be fitted by a registered installer, or approved by your local building control officer.

Works must be carried out with care to meet the requirements of Health and Safety‡ and comply with the Health and Safety rules, and any new regulations introduced during the lifetime of these instructions.. Particular attention should be drawn to:

- **Handling:** The appliance is heavy. Adequate facilities must be available for loading, unloading and site handling.
- **Fire Cement:** Some fire cement is caustic and must not come into contact with the skin. Protective gloves must be worn. Wash hands thoroughly with plenty of water after contact with skin.
- **Asbestos:** This appliance contains no asbestos. If there is the possibility of disturbing any asbestos in the course of installation seek specialist guidance and use appropriate equipment.
- **Metal Parts:** Take care when installing or servicing the stove to avoid personal injury.

**A faulty installation can cause danger to the inhabitants and structure of the building.**

**For users of this appliance:**

Your building insurance company may require you to inform them that you have installed a new heating appliance. Check that your cover is still valid after installing the appliance.

## 1. INSTALLING THE APPLIANCE

Each installation is unique to the property so it is not possible to give details to suit every setting. The installation must comply with Building Regulations and be made using "best practice" construction methods.

Many fireplace openings have a supporting lintel. Do not remove without supporting the remaining structure of the building. **Do not support the structure with the appliance or the flue system.**

- 1.1 **Take care when installing the appliance. Careless handling and use of tools can damage the finish and/or area.**
- 1.2 To make the fitting of the Riva MF easier, gain better access to the flue connection and protect paintwork from damage, remove the internal components and the lower frame fitting screws. The ashpit door, door and the front trim may be removed on Riva products.

- 1.3
  - Slide the Riva MF into the opening
  - **(Riva Only)** If the Riva MF is to be fitted with a 4 sided frame, fit the frame before fixing the appliance in to position.
  - **(Riva Only)** Check the fit of all frame options before fixing the appliance into position

**Some installations may require the frame to be fitted before final fixing.**

  - Fix in place using the fixing holes located under the ashpan, see diagram
  - Fix using the kit provided

Tools required 10mm A/F spanner /socket wrench and masonry drill)

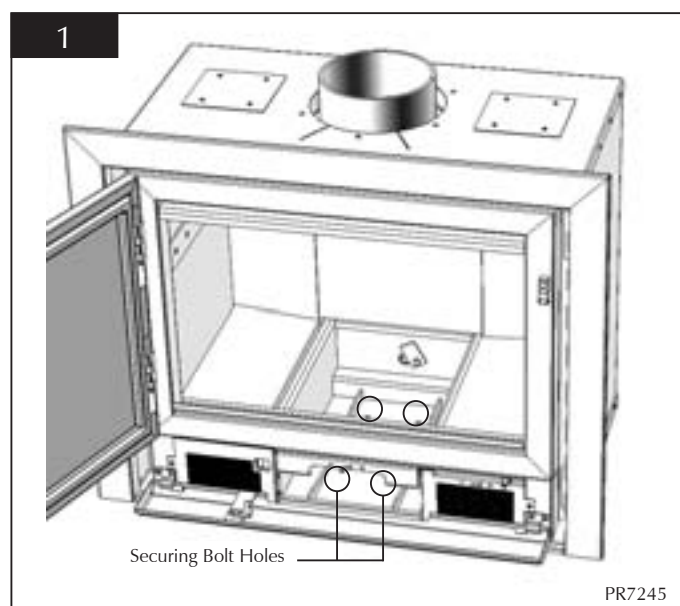

- Ensure that the flange of the Riva MF is still flat against the opening after tightening the fixing screws
- 1.4 Fill any void at the back or sides of the box with 6:1 vermiculite / cement mix or any other good quality non-combustible insulation material. It is important that the back and sides of the box are well insulated.
  - 1.5
    - Connect the flue liner and flue adaptor to the Riva MF by inserting the flue spigot from the inside of the Riva MF
    - Slide the flue pipe or liner adaptor inside the spigot
    - Seal the flue to the spigot using fire cement
    - Seal the spigot to the inside of the Riva MF using fire cement. See diagrams 2, 3, 4.

In The U.k:

\* England and Wales – Document J / Scotland - Part F/  
Document J (Republic of Ireland only)

\*\* In the U.K BS 8303, BS 6461, BS 7566

† registered body: HETAS (GB only)/INFO (Eire)

‡ Health and Safety at Work Act 1974

# INSTALLATION INSTRUCTIONS

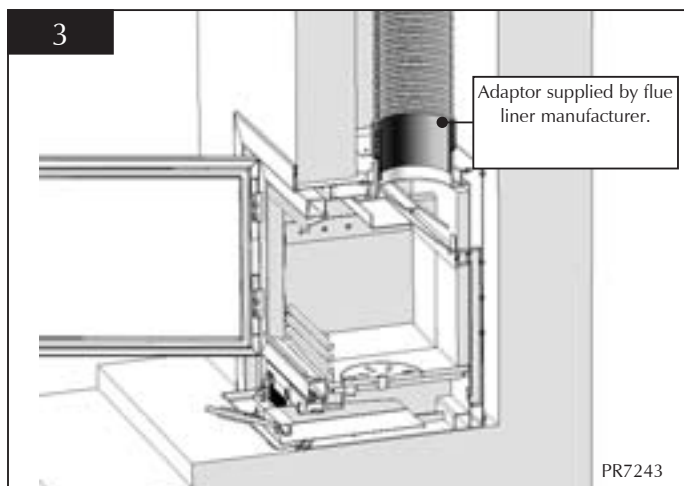
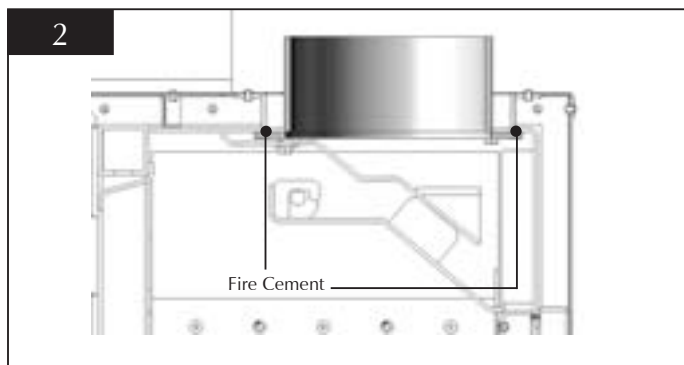

1.6 If the Riva MF is installed on an unlined, masonry flue:

- Fit a non-combustible closure plate to locate the first section of single wall flue pipe from the Riva MF to the old system
  - Make the connection as with a flue liner system
- Do not connect the system into large voids that could exist in older chimney systems. If this is the case consider using a flue lining system to improve the Riva MF operation. See diagram 16

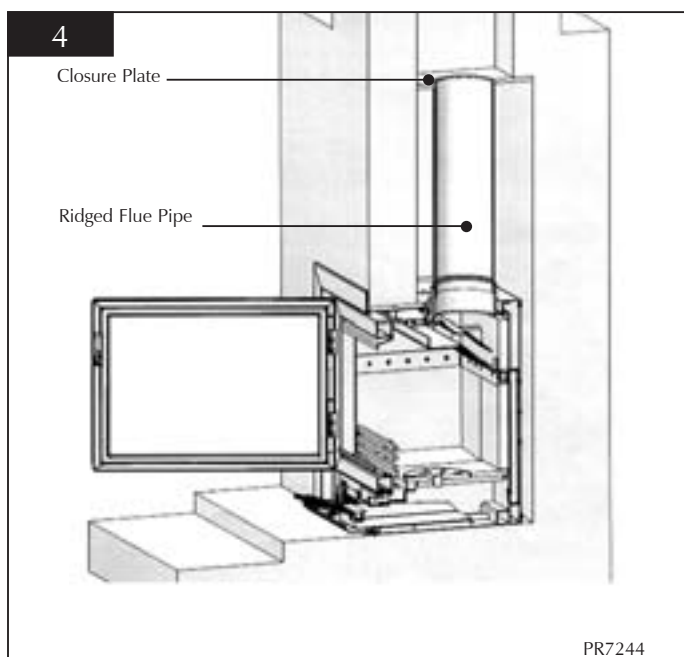

## 2. REMOVAL OF THE LOG GUARD

2.1 To remove the Log guard:

- Lift Log Guard clear of the supporting brackets
  - Rotate to clear the sides of the door opening.
- Do not use appliance without the log guard in position.**

## 3A. DOOR REMOVAL (RIVA)

(Tools required – None)

3a.1 To remove the door from the Riva MF:

- Open the door by approximately 25mm
- Lifting the door free of the hinge blocks on the left of the door
- Lie the door face down on a soft flat surface, to protect the paintwork and glass

3a.2 Take care to protect the top left hand corner of the door to avoid damage to the paintwork.

## 3B. DOOR REMOVAL (RIVA AVANTI)

(Tools required - Large flat-blade screwdriver)

3b.1 To remove the door from the Riva Avanti:

- Remove the hinge pin
- Unscrewing the hinge pin from the body of the Riva and pulling the pin out of the hinge blocks does this.
- Support the weight of the door before removing the pin
- The door should be kept in the closed position when the pin is removed.
- Release the door catch to lift the door clear of the hinge blocks

3b.2 Lie the door on a soft flat surface, to protect the glass and paintwork.

3b.3 Replace the door in the reverse order from removal. Do not hang the door from the catch only when replacing, as this could damage the catch mechanism.

3b.4 Care should be taken to fully support the weight of the door during the removal and replacement, as the door assembly is heavy.

## 4. ASHPAN DOOR REMOVAL (RIVA)

(Tools required – 2.5mm A/F Hex socket key)

4.1 To remove the ashpan door from the appliance,

- Lower the door to expose the hinge fixing screws (2 each hinge) Diagram 5

# INSTALLATION INSTRUCTIONS

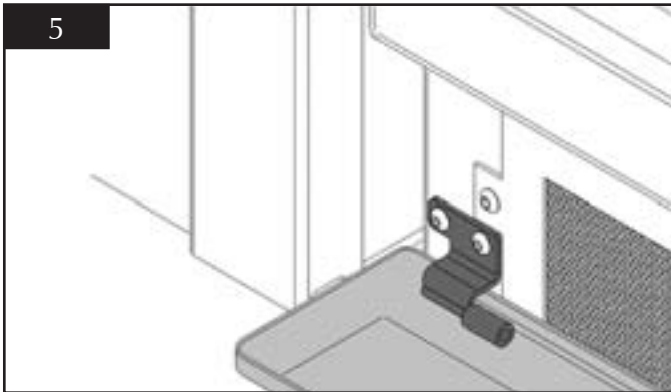

- Remove the fixing screws and lift the ashpit door clear of the appliance

4.2 The replacement of the system is the reverse of the previous operations.

## 5. BAFFLE REMOVAL (ALL)

(Tools required – None)

The Riva MF is fitted with a twin baffle system, consisting of upper and lower baffles, Diagram 6.

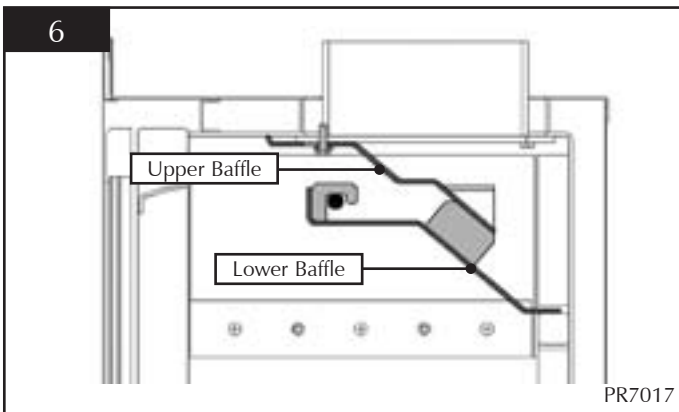

- 5.1 Remove the log guard from the Riva MF to give access to the firebox.
- 5.2 **First** remove the **Lower Baffle**, see diagram 7:
- Lift the front edge to unhook it from the support bars
  - Pull the baffle forward to disengage the rear edge from the location above air inlet holes
  - Rotate the baffle to remove from the firebox through the door opening

5.3 **Second** remove the **Upper Baffle**, see diagram 8:

- Pull forward to disengage it from the hanging points at the top of the firebox

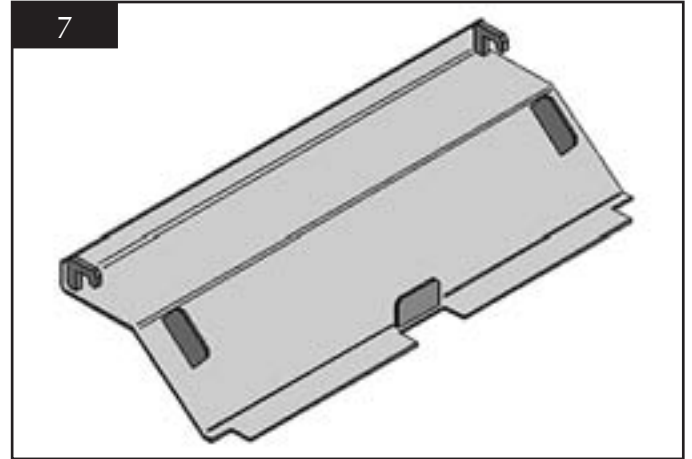

- Rotate the baffle to remove from the firebox through the door opening

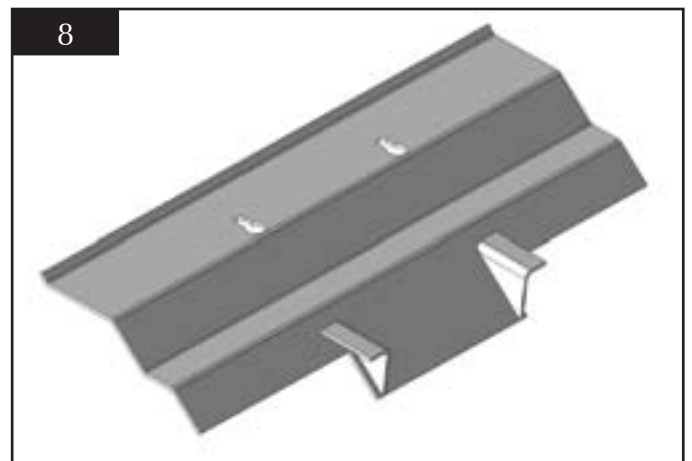

- 5.4 The replacement of the system is the reverse of the previous operations.
- 5.5 **Do not modify the baffle**

# INSTALLATION INSTRUCTIONS

## 6A. FIREGRATE REMOVAL (RIVA)

6a.1 To remove grate:

- First remove the centre grate by tipping the grate control boss downwards and lifting the centre grate vertically

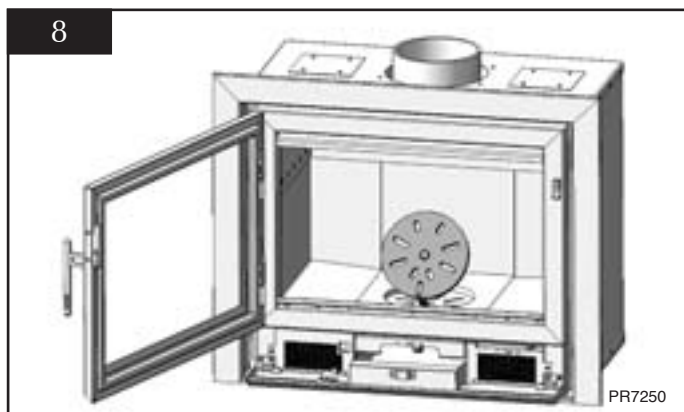

6a.2 The main grate can then be lifted by the front first and then rotating the main grate to clear the firebox.

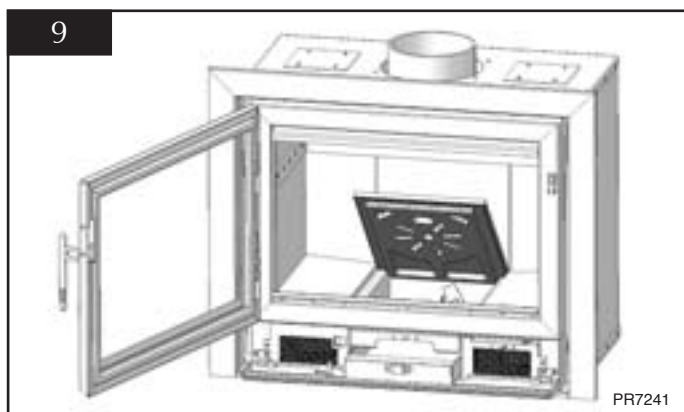

6a.3 Ensure that the seal tape on the underside of the grate is in good condition and correctly fitted. If not, replace with new. (Stovax part number 4998)

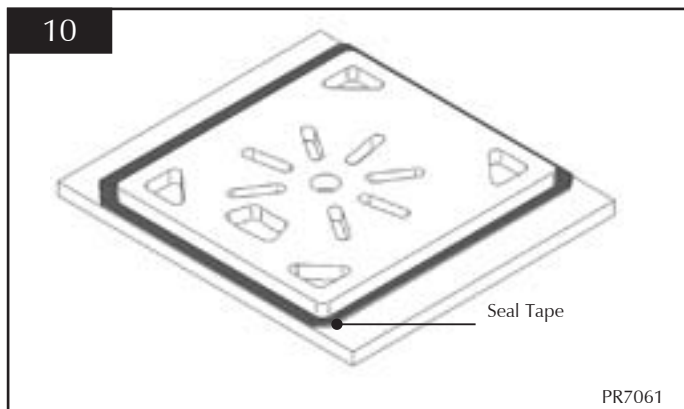

6a.4 Replace the grate in the reverse order from removal.

6a.5 The grate must sit flat on the side supports, with no debris trapped under it. Check that the centre grate sits flat and rotates freely with no debris trapped under it.

## 6B. FIREGRATE REMOVAL (RIVA AVANTI)

(Tools required – None)

6b.1 To remove the firegrate first remove the centre grate:

- Disconnect the operating linkage from the grate
  - Move the Primary air control to the fully open position
  - Spring the operating link forward to disconnect the balljoint
- The centre grate can then be lifted out from inside of the firebox.

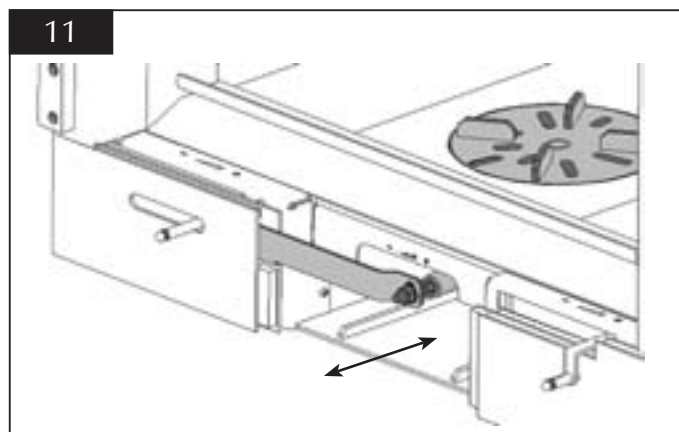

6b.2 The main grate can then be lifted out of the firebox.

6b.3 Replace the grate system in the reverse order from removal.

6b.4 Ensure that the seal tape on the underside of the grate is in good condition and correctly fitted. If not replace with new. (Stovax part number 4998)

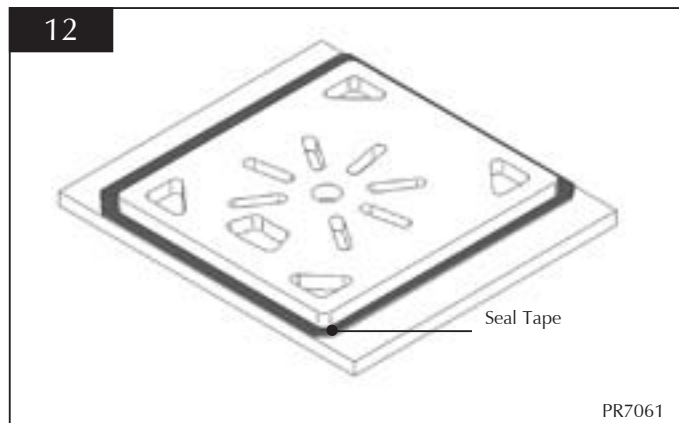

6b.5 The grate must sit flat on the side supports, with no debris trapped under it. Check that the centre grate sits flat and rotates freely with no debris trapped under it.

# INSTALLATION INSTRUCTIONS

## 7. BRICK REMOVAL (ALL)

(Tools required – None)

7.1 The bricks must be removed and replaced in the correct order, as shown in diagram 13/14/15, after removing the baffles and grate system.

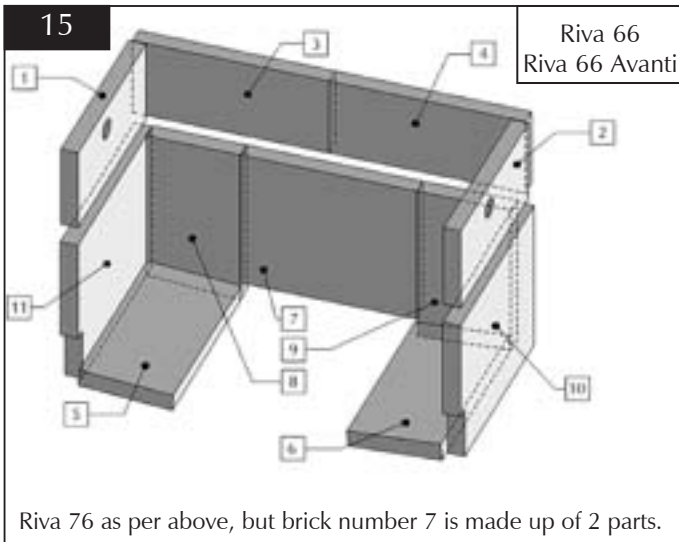
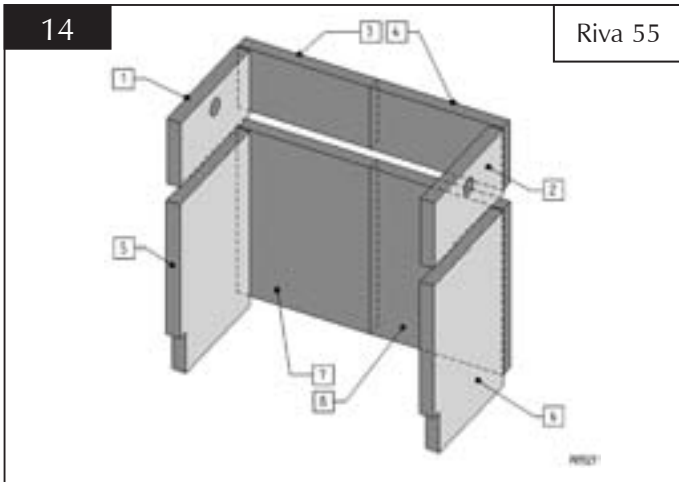
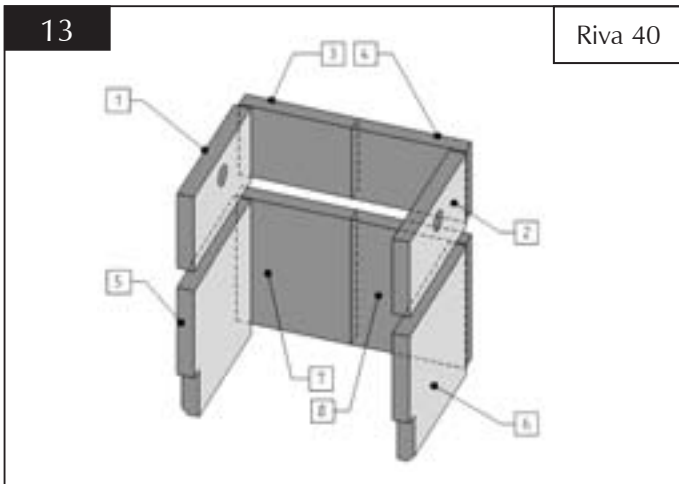

7.2 Replace the bricks in the reverse order from removal.

## 8. FITTING THE FRAME (RIVA)

(3 sided 'Profil' frame shown)  
(Tools required – 2.5mm A/F Hex socket key)

8.1 The frame is in 2 parts, the lower frame and the main 3 sided section.

To fit the frame:

- Locate the main frame on the top clips on the firebox, See diagram 16

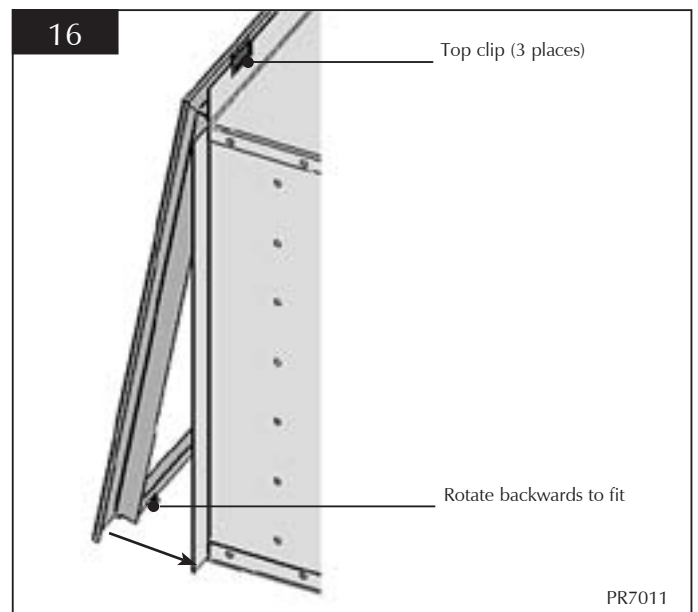

- Rotate the main frame into position on the front of the appliance body

- Fix in place with the trim fixing screws

- Fix the lower frame into position using the two fixing screws supplied, See diagram 17

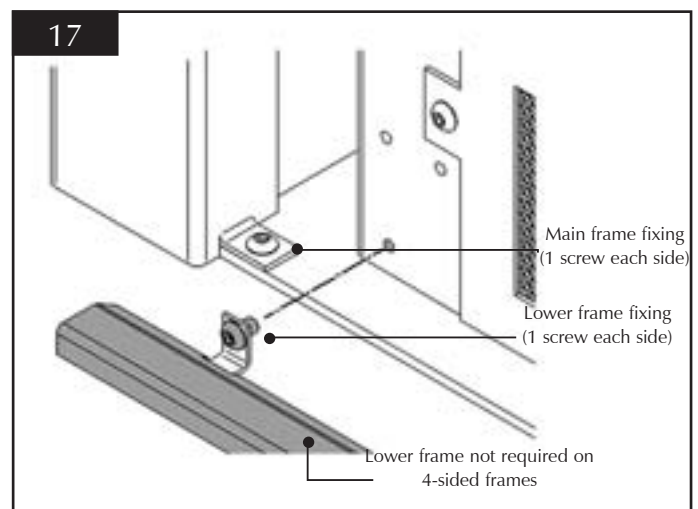



# INSTALLATION INSTRUCTIONS

- 8.2 The removal of the frame is the reverse of the previous operations.
- 8.3 Protect the Riva MF paintwork from possible damage and marking from building debris during installation.

## 9. FITTING CONVECTION AIR DUCTS

### Riva 55/66/66 Avanti/76 Only

Convection air may be ducted from the Riva MF to distribute warm air to other parts of the building. The distance this air may be ducted, and the position of the ducts will depend on the layout of the property.

A convection air ducting kit can be purchased from your Stovax dealer (Stovax part number 8572), as shown in diagram 18.

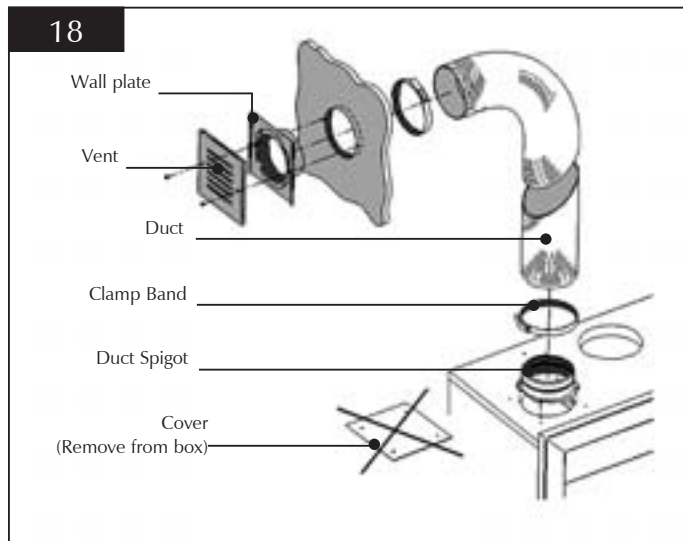

9.1 To fit the ducts:

- Remove the cover plates on the top of the firebox, by drilling out the fixing rivets
- Fit the duct spigots with either pop rivets or self-tapping screws
- Fit and seal ducting to the spigots

9.2 **Due to the high temperature of the ducts combustible material must be placed no closer than 100mm to the surface. The duct exits and grills must only be placed in a non-combustible wall panel.**

9.3 Protect or place the exit ducts at a high level, as the grill surfaces become very hot when in use.

Use a suitable guard if the exit is at low level to prevent touching or obstruction. Do not place combustible items near the operating duct exit as conducted and radiated heat could cause a fire hazard.

9.4 Following completion of the fitting of the ducts replace and finish the final 300mm of masonry above the front of the Riva MF. See diagram 20.

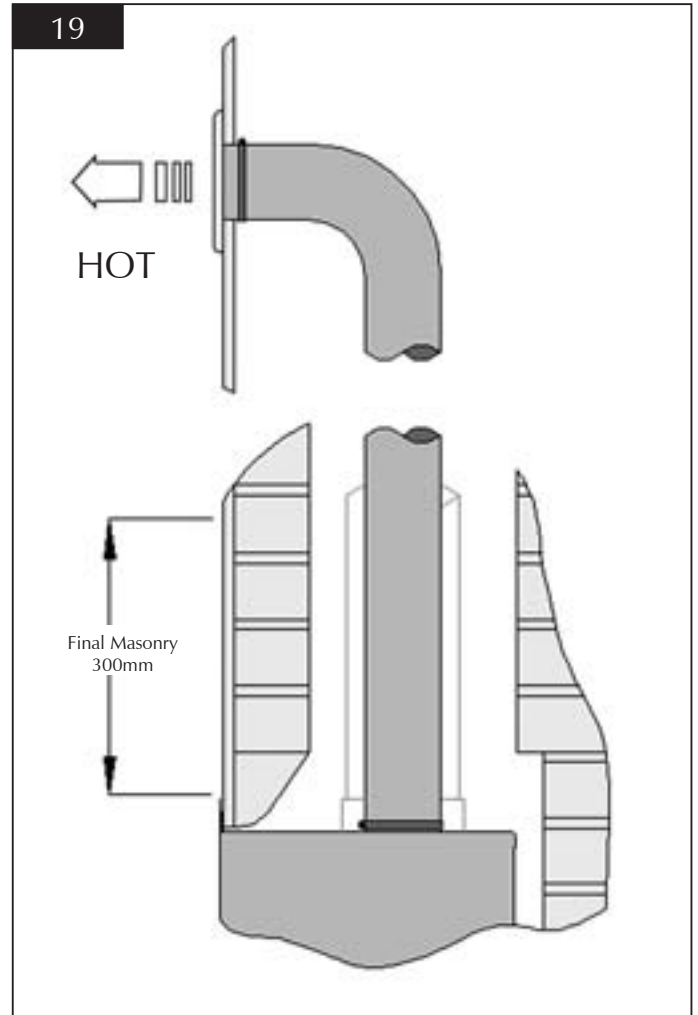



# COMMISSIONING

## COMMISSIONING

### 1.1 To commission:

- Replace the firebricks, baffle, and log retainer
- Check the door alignment and catch operation, adjust if required, see Installation Section 6. Adjusting Door hinges
- Check the soundness of door seals, castings and joints
- Check the operation of the air controls

### 1.2 Now carry out a final smoke draw test:

- First warm the flue with a blowlamp, or similar, for about 10 minutes
- Place a smoke pellet on the centre of the grate, with the air controls open
- Close the door  
Smoke should now be drawn up the flue and be seen to exit from the flue terminal
- Complete test with all doors and windows closed in the room where the appliance is fitted
- If there are any extractor fans in adjacent rooms, the test must be repeated with the fans running on maximum and interconnecting doors open
- Check the effect of ceiling fans during the test

If the test fails, re-check the suitability of the flue system and ventilation. An inadequate air supply to the room is potentially dangerous.

- Light the appliance and slowly increase the temperature to operating levels
- Ensure no combustion products enter the room
- Open the main fire door when the appliance reaches operating condition and carry out a spillage test with a smoke match or pellet around the door opening

### 1.3 If excessive spillage occurs:

- Allow the appliance to cool and re-check the flue system and ventilation

### 1.4 Finally:

- **Explain the safe operation of the appliance and the use of the controls to the user and the importance of only using suitable fuels**
- **Explain the cleaning and routine maintenance requirements**

- **Explain the requirement to use a suitable fireguard when children, elderly or infirm persons are near the appliance**

- **Record dealer/supplier details and installer details in *Instructions***

- **Record serial number in page 3 of *Instructions***  
This number is required when ordering spare parts and making warranty claims

- **Give the copy of the *Instructions* to the customer**

# MAINTENANCE and SERVICING

For a complete list of spare parts and accessories contact your Stovax or call 01392 474011

## 1. ANNUAL SERVICE

1.1 At the end of the heating season strip, inspect and clean the appliance as detailed:

- Allow appliance to cool

- Remove all of the following internal parts; baffle, firebricks, complete grate, and ash pan. For Multi fuel versions remove the complete grate and ash pan.

See sections 5 and 6 on how to remove the baffles and firebricks. Take care handling firebricks, as they can become fragile after a period of use.

- Vacuum clean any remaining ash and debris from the inside of the appliance.

Stovax offer a filter/collection attachment for your vacuum cleaner to protect it from fire ash. Ash Clean (Stovax Part No. 2091).

- Clean the internal surfaces of the appliance using a wire brush and scraper as required  
Vacuum and brush the resulting debris from the appliance.

- Clean the grate parts with a wire brush, and check the parts for any damage

- Replace any damaged parts

- Check and clean the firebricks with a soft brush

- Replace broken bricks

Some surface damage will occur during use. The life of the bricks will depend on the type of fuels burnt and the level of use. Damaged bricks should be replaced as soon as possible.

- Re-fit cleaned internal parts

- Remove the glass from the door, See section 7 page 20, and discard all old rope seals

- Remove the door rope seal from the outer edge of the door and clean the old glue from the door sealing rope groove

- Clean the door glass using Stovax Glass cleaner and a soft cloth

Do not use abrasive cleaners to remove tar or soot deposits from the glass.

- Replace the glass edge seal with new and re-fit the glass into place in the door

- Fit new door rope seal, gluing it in place with Stovax Thermic Seal rope adhesive

- Press the new door sealing rope into the locating groove, placing the joint in the middle of the lower edge of the door.

When fitting new door seals, close the appliance door and leave for at least 12 hours before using. This allows the adhesive to fully bond to the seal before use.

- Lightly oil the door catch mechanism and hinge pins  
Avoid getting oil onto the door seals and glass.

To refresh painted finishes use Stovax Thermolac paint.

1.2 Use genuine Stovax replacement parts to keep your appliance in safe and efficient working order. Your local Stovax dealer can provide you with the parts you require.

This is a list of the maintenance products you may need to use

Task	Product name	Stovax Code Number
Glass cleaning	Stove glass cleaner 500ml (wipe on)	4111
	Stove glass cleaner (spray on)	4103
Preventing build-up of creosote in flue	Protector (15 sachets)	7002
	Protector (1kg tub)	7025
Sealing flue pipe joints	Fire Cement (500g tub)	2020
	Fire Cement (600g cartridge)	2021
Re-painting	Thermolac Black (400ml aerosol)	2019
	Thermolac Black (200ml brush-on)	2057
Cleaning matt black Appliances	Colloidal black (85ml)	7000
Protecting your hands	Heat resistant leather gloves	4008
Door sealing rope	14mm Black rope seal (handy pack)	5000
	14mm Black rope seal (25m reel)	4670
Glass sealing tape	3mm Black rope seal (handy pack)	4975
	3mm Black rope seal (25m reel)	4974
Thermic seal glue	(50ml bottle)	5037
Soft rope	10mm diameter	4965
Ash Clean	Vacuum Cleaner Attachment	2091

These products, available from your local Stovax dealer, along with regular maintenance and use of correct fuels, will keep your appliance in the best possible condition.

1.3 If you require more information about Stovax group products visit our web site [www.stovax.com](http://www.stovax.com)

# MAINTENANCE and SERVICING

- 1.4 Using the appliance for the first time:
- Burn at a low output for the first day of use  
This allows the seals, fixing glues and paint to fully cure.
- 1.5 During this time the appliance may give off some unpleasant odours:
- Keep the room well ventilated to avoid a build-up of fumes.
- 1.6 Your Stovax dealer can carry out service and maintenance.

## 2. REMOVAL OF THE LOG GUARD

- 2.1 To remove the Log guard:
- Lift Log Guard clear of the supporting brackets
  - Rotate to clear the sides of the door opening.
- Do not use appliance without the log guard in position.**

## 3. DOOR REMOVAL (ALL)

- 3.1 See *Section 3a and 3b Door Removal Riva - 3a and Avanti - 3b* in *Installation section*.

## 4. ASHPAN DOOR REMOVAL (RIVA)

- 4.1 See *Section 4 Ashpan Door removal (Riva)* in *Installation section*.

## 5. BAFFLE REMOVAL (ALL)

- 5.1 See *Section 5, Baffle Removal (all)* in *Installation Section*.

## 6. FIREGRATE REMOVAL (ALL)

- 6.1 See *Section 6a and 6b, Firegrate Removal a) Riva and b) Avanti* in *Installation Section*.

## 7. BRICK REMOVAL (ALL)

- 7.1 See *Section 7 Firebrick Removal* in *Installation section*.

## 8. FITTING THE FRAME (RIVA)

- 8.1 See *Section 8 Fitting the Frame* in *Installation section*.

## 9. FITTING CONVECTION AIR DUCTS

- 9.1 See *Section 9 Fitting Convection Air Ducts* in *Installation section*.

## 10. FITTING A NEW DOOR GLASS ALL MODELS

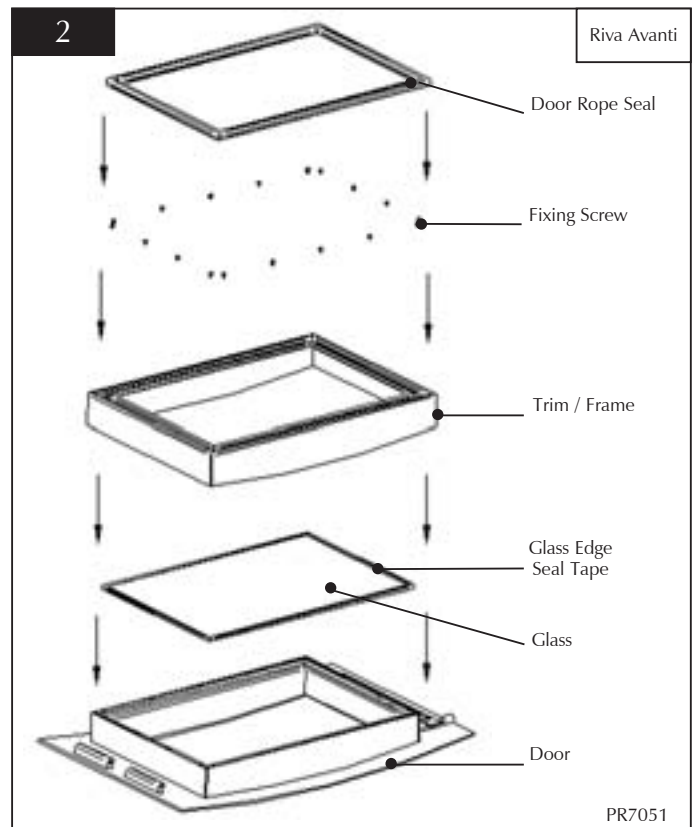
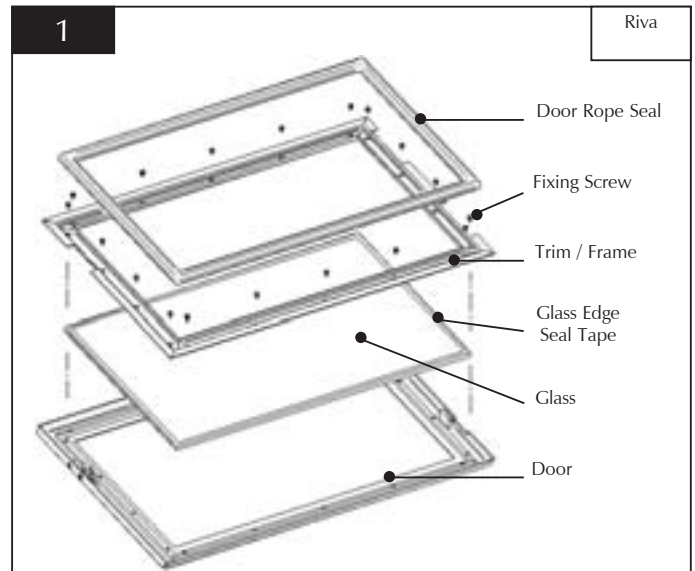

- 10.1 To maintain the safe use of your appliance you may need to replace a damaged door glass. To complete this operation:

### Riva 66, See 3A

- Remove the door, by opening 25mm, removing the hinge pins and lifting the door free of the hinge blocks

# MAINTENANCE and SERVICING

## Riva 66 Avanti see 3B

- Lay the door face down on a soft flat surface, to protect the paintwork and glass
  - Remove the old door rope seal and scrape old glue from the locating groove  
Clean with a dry cloth to remove dust and debris.
  - Remove the glass clip fixing screws with a 2.5A/F hexagon key  
The old glass can then be lifted clear of the door (Note how the edge sealing tape is fixed).
  - Dispose of the old glass safely.
  - Clean and re-paint the rear of the door if required  
Clean the screws with light oil and coat with high temperature anti-seize grease, this will aid future removal.
  - Fit the edge sealing tape to the new glass and place the glass into position in the door
  - Place the door frame/trim back into position and refix with the cleaning fixing screws  
Do not over tighten the clips as this could break the glass.
  - Squeeze a generous bead of fresh Stovax Thermic Seal glue into the rope locating groove  
**Do not glue over the screw heads.**
  - Press the new Stovax door sealing rope into the locating groove, placing the joint in the middle of the lower edge of the door
  - Refit the door on to the appliance and close the door to apply pressure to new rope  
Leave the appliance closed for at least 12 hours before lighting the appliance and use at a low output for approximately one day.
- 10.2 Fit only original Stovax ceramic glass, which is suitable to use in high temperature applications.
- 10.3 Using the appliance with a damaged door glass could cause dangerous fumes to enter the room, or the appliance to over fire, resulting in damage.

## 11. FITTING A NEW DOOR SEAL

- 11.1 To maintain the safe use of your appliance you need to replace damaged or worn door sealing rope. To complete this operation:
- Remove the door from the appliance, by opening 25mm, and lifting the door free of the hinge blocks
  - Lay the door face down on a soft flat surface, to protect the paintwork and glass
  - Remove the old rope and scrape old glue from the locating groove  
Clean the locating groove with a clean dry cloth to remove all old dust and debris.

- Squeeze a generous bead of fresh Stovax Thermic Seal glue into the rope locating groove
- Press the new Stovax rope into the locating groove, placing the joint in the middle of the lower edge of the door
- Refit the door and close the door to apply pressure to the new rope
- Leave the appliance closed for at least 12 hours before lighting the appliance and using at a low output for approximately one day

- 11.2 Using the appliance with a damaged door seal can cause dangerous fumes to enter the room, or the appliance to over fire, resulting in damage.

## 12A. ADJUSTING DOOR CATCH - RIVA

- 12a.1 To maintain the safe use of your Riva, you may need to adjust the door catch to ensure safe correct closing of the door.

To Complete this operation:

- Open the main fire door to give access to the fixed part of the door catch as shown in diagram 7.
- Using a 2.5mm A/F hexagon key loosen the 2 fixing screws, as shown in diagram 7
- Reposition the catch block to achieve a correct fit  
This may need a trial and error approach to find the correct position.

- 12a.2 If the door feels loose after correcting the catch operation the door rope seal is worn and requires replacement, as detailed in section 7.

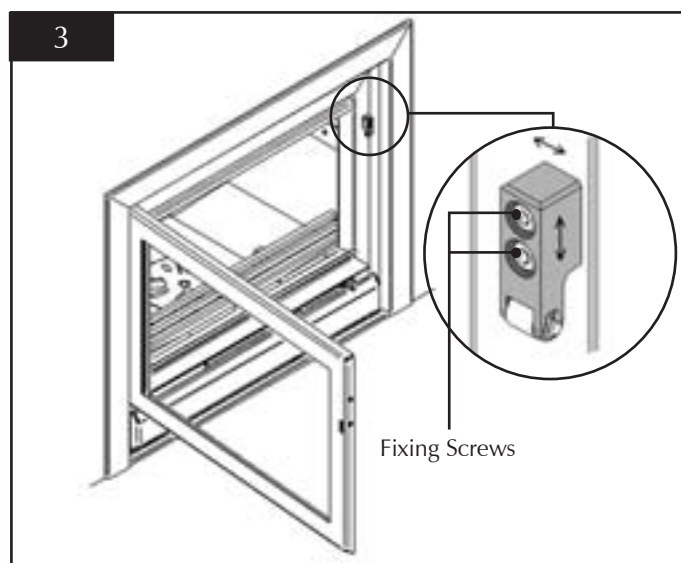

# MAINTENANCE and SERVICING

## 12B. ADJUSTING DOOR CATCH RIVA AVANTI

(Tool required - 13mm A/F spanner)

12b.1 To maintain the safe use of your Riva, you may need to adjust the door catch to ensure safe correct closing of the door.

To Complete this operation:

- Open the main fire door to give access to the fixed part of the door catch as shown in diagram 4

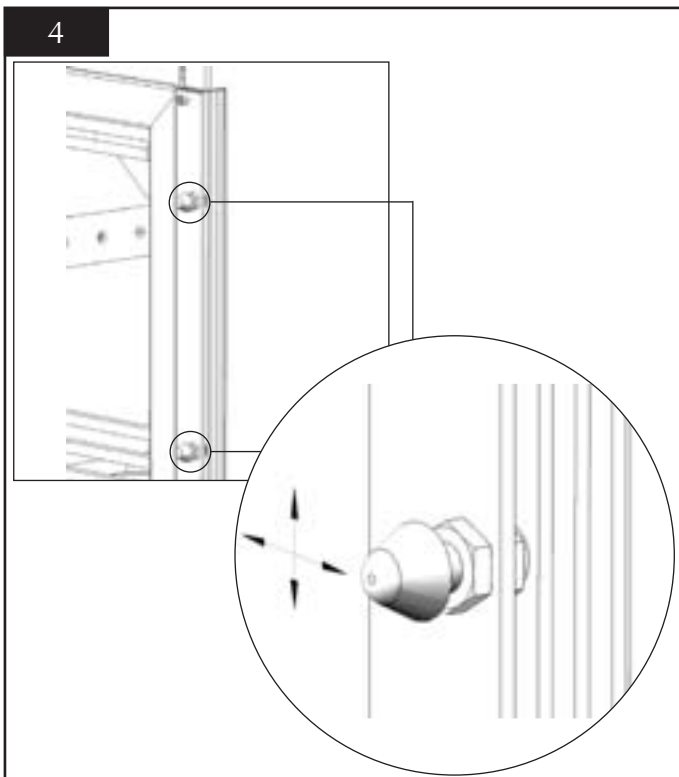

- Use a 13mm A/F spanner to loosen the locking nut holding the catch block shown in diagram 8,
- Reposition to achieve the correct fit  
This may need a trial and error approach to find the correct position.

12b.2 If the door still feels loose after correcting the catch operation, the door rope seal is worn and requires replacement, as detailed in section 8.

## 13A. ADJUSTING DOOR HINGES - RIVA

13a.1 To maintain the safe use of your Riva, you may need to adjust the door hinges to ensure safe correct closing of the door.

To complete this operation:

- Open the main fire door to give access to the hinge block as shown in diagram 5
- Use a 3mm A/F hexagon key to loosen fixing screws, diagram 9,
- Reposition the hinge blocks to achieve a correct fit  
This may need a trial and error approach to find the correct position.

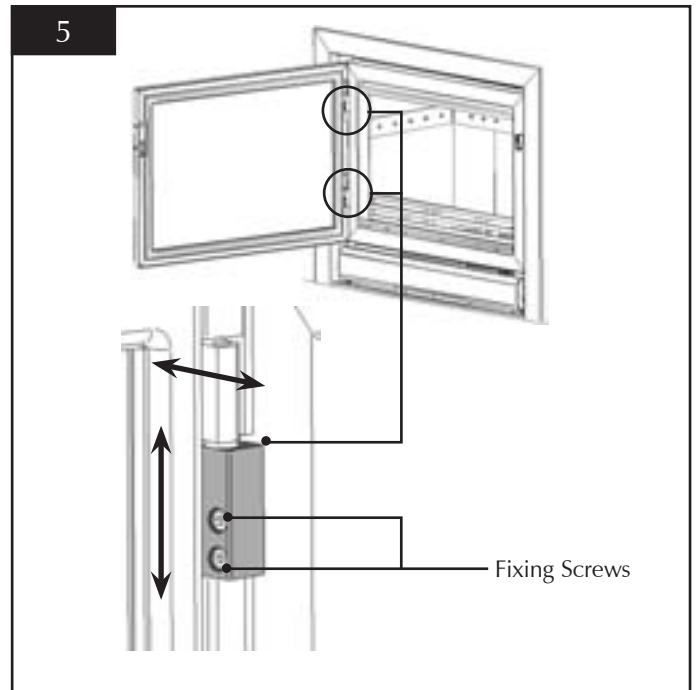

## 13B. ADJUSTING DOOR HINGES RIVA AVANTI

13a.1 To maintain the safe use of your Riva, you may need to adjust the door hinges to ensure safe correct closing of the door.

To complete this operation:

- Open the main fire door to give access to the hinge block as shown in diagram 6
- Loosen the 6 fixing screws using a 4mm A/F hexagon head socket key to adjust the door alignment
- Turn screw A to level the door
- Turn screw B to raise or lower the door
- Re-tighten the fixing screws and check alignment  
This may require a trial and error approach to find the correct position.

# MAINTENANCE and SERVICING

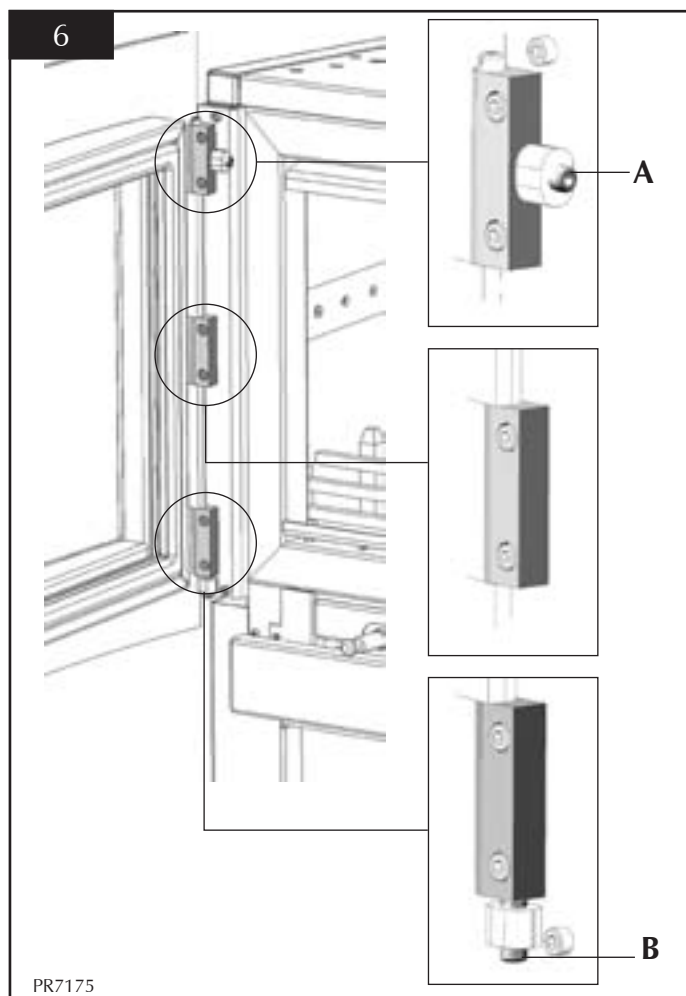

## 14. ADJUSTING ASHPAN COVER HINGES - RIVA

(Tool required - 2.5mm A/F Hex socket key)

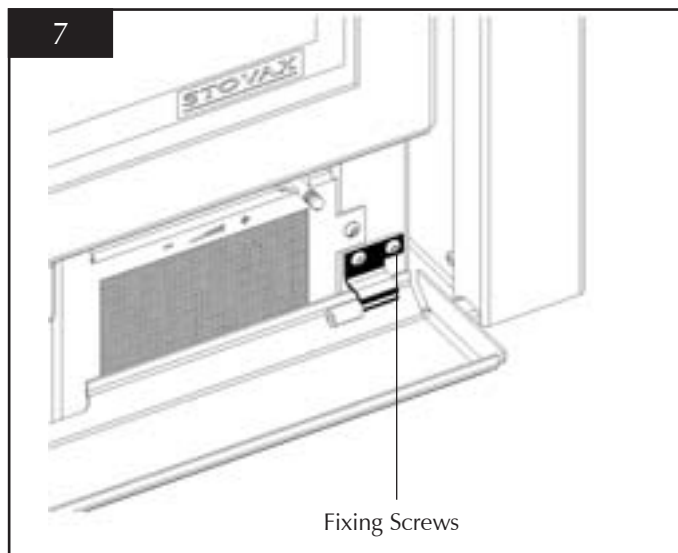

- 14.1 Correct the fit of the ashpit door by loosening the hinge fixing screws and repositioning the hinges.

## 15. ADJUSTING ASHPAN DOOR TOUCH LATCH - RIVA

(Tool required - 2.5mm A/F Hex socket key)

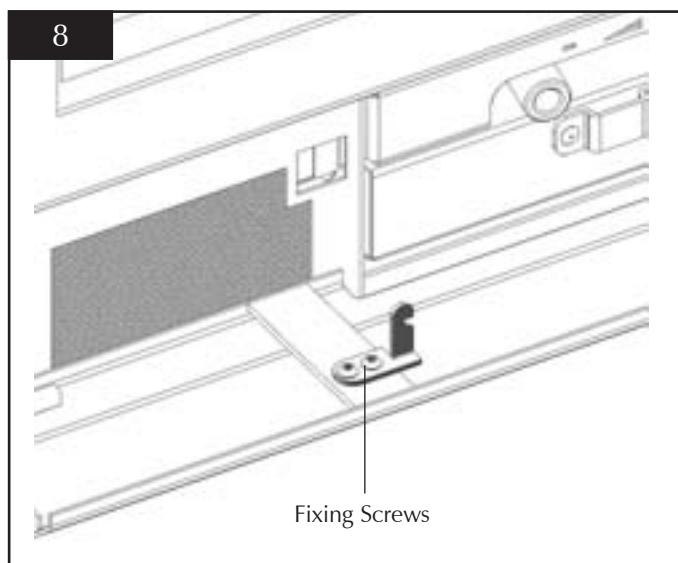

- 16.1 Correct the operation of the ashpit door touch latch by loosening the latches fixing screws and repositioning the latch. This may need a trial and error approach to find the correct position.



# BASIC SPARE PARTS LIST

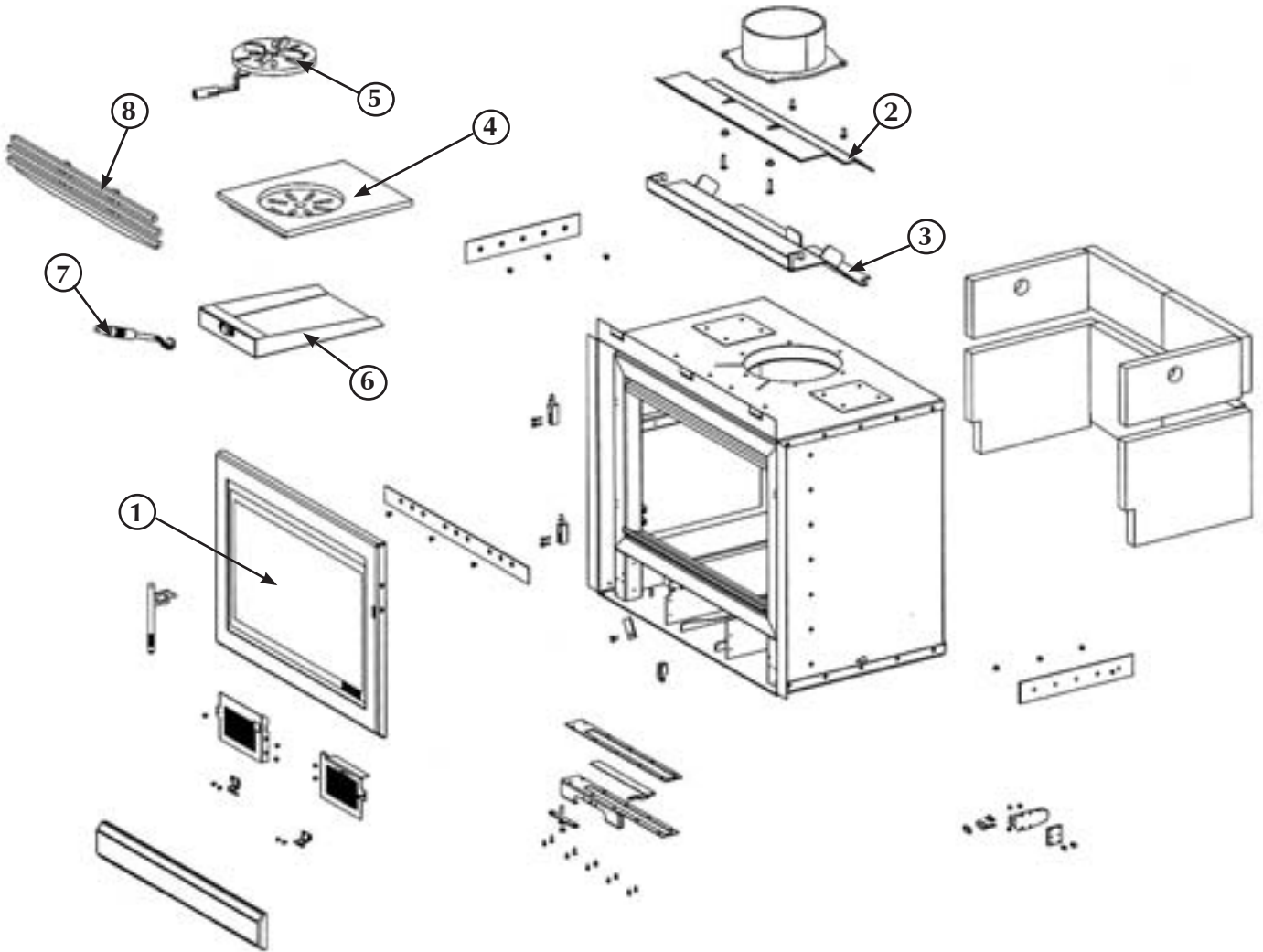

## RIVA 40 MF CASSETTE

Diagram No.	Description	Part No.
1	Door Glass	GL7033
2	Upper Baffle	RVAC075
3	Lower Baffle	RVAC076
4	Centre Grate	RVAC074
5	Main Grate	RVAC081
6	Ashpan	RVAC073
7	Ashpan Tool	RVAC004
8	Log Guard	RVAC072

## RIVA 55 MF CASSETTE

Diagram No.	Description	Part No.
1	Door Glass	GL7085
2	Upper Baffle	RVAC094
3	Lower Baffle	RVAC095
4	Centre Grate	RVAC093
5	Main Grate	RVAC100
6	Ashpan	RVAC073
7	Ashpan Tool	RVAC004
8	Log Guard	RVAC092

## RIVA 66 MF CASSETTE

Diagram No.	Description	Part No.
1	Door Glass	GL7032
2	Upper Baffle	RVAC042
3	Lower Baffle	RVAC043
4	Centre Grate	RVAC034
5	Main Grate	RVAC033
6	Ashpan	RVAC003
7	Ashpan Tool	RVAC004
8	Log Guard	RVAC005

## RIVA 66 AVANTI MF CASSETTE

Diagram No.	Description	Part No.
1	Door Glass	GL7032
2	Upper Baffle	RVAC042
3	Lower Baffle	RVAC043
4	Centre Grate	RVAC112
5	Main Grate	RVAC033
6	Ashpan	RVAC109
7	Ashpan Tool	RVAC004

## RIVA 76 WOOD BURING CASSETTE

Diagram No.	Description	Part No.
1	Door Glass	GL7072
2	Upper Baffle	RVAC180
3	Lower Baffle	RVAC181
4	Centre Grate	RVAC182
5	Main Grate	RVAC183
6	Ashpan	RVAC185
7	Ashpan Tool	RVAC004
8	Log Guard	RVAC184

# BASIC SPARE PARTS LIST

## RIVA 40 MF CASSETTE BRICKS

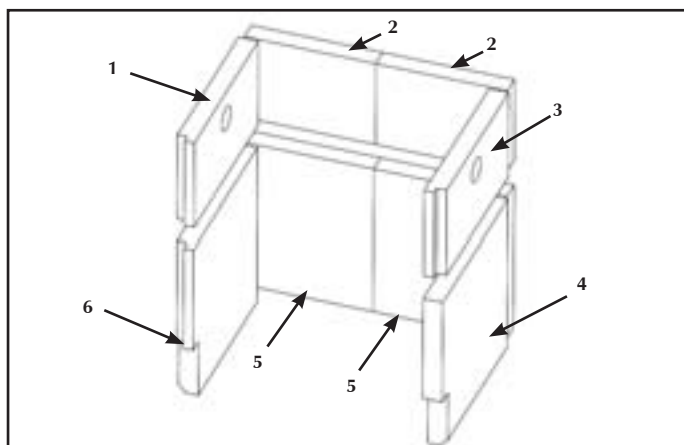

Diagram No	Part No.	Description
1	RV40BR1	Rear top LH/RH
2	RV40BR7	Side top RH
3	RV40BR4	Side bottom RH
4	RV40BR5	Rear bottom LH/RH
5	RV40BR3	Side bottom LH
6	RV40BR6	Side top LH

## RIVA 55 MF CASSETTE BRICKS

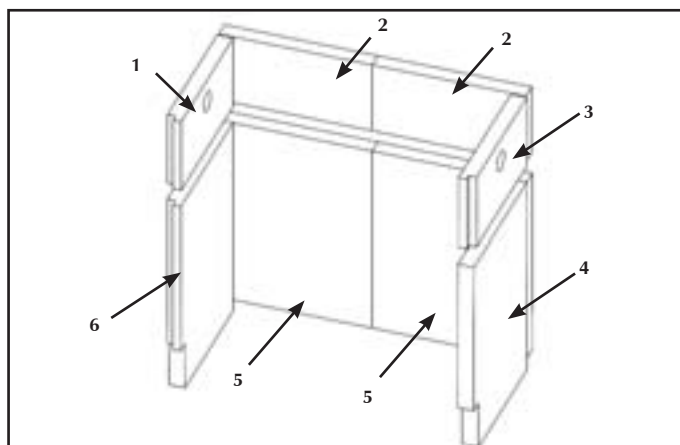

Diagram No	Part No.	Description
1	RV55BR1	Rear top LH/RH
2	RV40BR7	Side top RH
3	RV55BR5	Side bottom LH
4	RV55BR3	Side bottom RH
4	RV55BR4	Rear bottom LH/RH
5	RV40BR6	Side top LH

## RIVA 66 & 66 AVANTI MF CASSETTE BRICKS

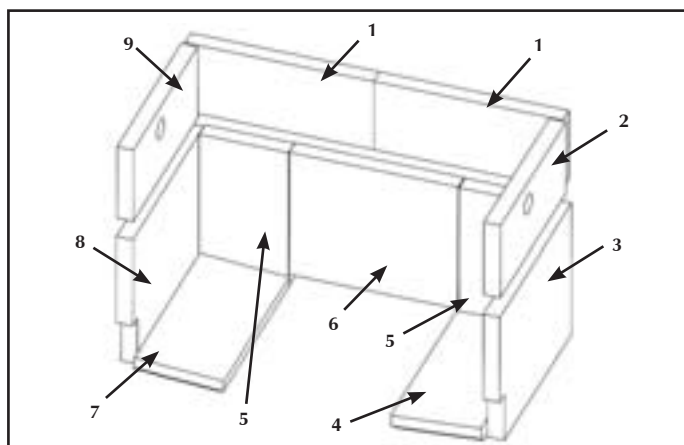

Diagram No	Part No.	Description
1	RV66BR1	Rear top LH/RH
2	RV66BR2	Side top RH
3	RV66BR3	Side bottom RH
4	RV66BR6	Base RH
5	RV66BR7	Rear bottom LH/RH
6	RV66BR4	Rear bottom centre
7	RV66BR5	Base LH
8	RV66BR9	Side bottom LH
9	RV66BR8	Side top LH

## RIVA 76 WOOD BURNING CASSETTE BRICKS

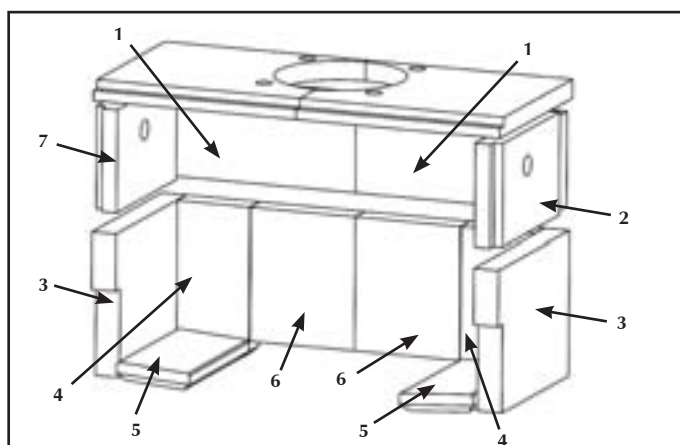

Diagram No	Part No.	Description
1	RV76BR1	Rear top LH/RH
2	RV76BR2	Side top RH
3	RV76BR3	Side bottom RH
4	RV76BR5	Base LH/RH
5	RV76BR6	Rear bottom LH/RH
6	RV76BR4	Rear bottom centre
7	RV76BR8	Side top LH

# SERVICE RECORDS

## 1ST SERVICE

Date of Service:.....

Next Service Due:.....

Signed:.....

Dealer's Stamp/HETAS Registration Number

## 3RD SERVICE

Date of Service:.....

Next Service Due:.....

Signed:.....

Dealer's Stamp/HETAS Registration Number

## 5TH SERVICE

Date of Service:.....

Next Service Due:.....

Signed:.....

Dealer's Stamp/HETAS Registration Number

## 7TH SERVICE

Date of Service:.....

Next Service Due:.....

Signed:.....

Dealer's Stamp/HETAS Registration Number

## 9TH SERVICE

Date of Service:.....

Next Due:.....

Signed:.....

Dealer's Stamp/HETAS Registration Number

## 2ND SERVICE

Date of Service:.....

Next Service Due:.....

Signed:.....

Dealer's Stamp/HETAS Registration Number

## 4TH SERVICE

Date of Service:.....

Next Service Due:.....

Signed:.....

Dealer's Stamp/HETAS Registration Number

## 6TH SERVICE

Date of Service:.....

Next Service Due:.....

Signed:.....

Dealer's Stamp/HETAS Registration Number

## 8TH SERVICE

Date of Service:.....

Next Due:.....

Signed:.....

Dealer's Stamp/HETAS Registration Number

## 10TH SERVICE

Date of Service:.....

Next Service Due:.....

Signed:.....

Dealer's Stamp/HETAS Registration Number

# EC Declaration of Conformity



The undersigned, representing the following :

Manufacturer
<b>Stovax Ltd</b> Falcon Road, Sowton Industrial Estate Exeter EX2 7LF

Herewith declare that the products :

Description	Product code
Riva 40 Cassette	RV40 / RV40B
Riva 55 Cassette	RV55 / RV55B
Riva 66 Cassette	RV66 / RV66B
Riva 66 Avanti Cassette	RV66AVC
Riva 76 Cassette	RV76 / RV76B

Steel fabricated stove body fitted with steel fabricated door sets, various decorative trim and firegrate options. Supplied in various sizes to give a range of heat output options.

are in conformity with the provisions of the following EC Directive(s) when installed in accordance with the installation instructions in the product documentation :

98/106/EEC Construction Products Directive

and the standards referenced below have been applied :

EN 13229 : 2001 Inset appliances including open fires fired by solid fuel – Requirements and test methods.

EN 50165 : 1997 Electrical equipment of non-electrical appliances for household and similar

Provisions to which the product conforms :

Product : Inset Roomheater fired by solid fuel as covered under the scope of the standards listed.		
Intended use : Space heating in residential buildings.		
Characteristic	Performance	Report
Fire safety	Satisfies	
Emission of combustion products	Riva 40 (RV40 / RV40B) CO @ 13% O <sub>2</sub> Wood 0.2% - Briquetted fuel 0.28%	50970/23
	Riva 55 (RV55 / RV55B) CO @ 13% O <sub>2</sub> Wood 0.11% - Briquetted fuel 0.07%	50970/24
	Riva 66 (RV66 / RV66B / RV66AVC) CO @ 13% O <sub>2</sub> Wood 0.18% - Briquetted fuel 0.10%	50970/25/26
	Riva 76 (RV76 / RV76B) CO @ 13% O <sub>2</sub> Wood 0.08%	
Release of dangerous substance	None	
Surface temperature	Satisfies	
Mechanical resistance (to carry a chimney/flue)	Maximum weight to be supported 25Kg	
Thermal output / Efficiency	Riva 40 (RV40 / RV40B) Wood 4.9Kw @ 77% - Briquetted fuel 4.9Kw @ 82%	50970/23
	Riva 55 (RV55 / RV55B) Wood 8.0Kw @ 82% - Briquetted fuel 8.00Kw @ 84%	50970/24
	Riva 66 (RV66 / RV66B / RV66AVC) Wood 8.0Kw @ 80% - Briquetted fuel 8.00Kw @ 76%	50970/25/26
	Riva 76 (RV76 / RV76B) Wood 9.5Kw @ 68%	

Test laboratory : 608 / 1641

Name : D. J. Saunders

Position : Design Engineer

Signature :

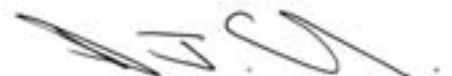

Date : 02 / 05 / 2007

# STOVAX

Stovax Ltd, Falcon Road, Sowton Industrial Estate, Exeter, Devon, England EX2 7LF

Tel: (01392) 474011 Fax: (01392) 219932 E-mail: [info@stovax.com](mailto:info@stovax.com) [www.stovax.com](http://www.stovax.com)