



15 Discovery Way, Acton, MA 01720

Phone: (978)263-3584, **Fax:** (978)263-5086

Web Site: www.piacton.com

**Instructions for Mounting and Operation
of the Princeton Instruments Model XS-432
75 Watt Xenon Light Source System**

Description:

The Princeton Instruments Model XS-432 is a 75 watt xenon light source system designed for use with Acton series monochromators. It consists of a 75 watt xenon lamp (Hamamatsu L2174-01 or Osram XBO 75 W/2), a housing with light collection mirror, and a regulated power supply (Optiquip Model 1200). The XS-432 is assembled, tested and aligned prior to shipment to minimize assembly at the customer facility. The lamp, however must be shipped separately for protection against damage, therefore must be installed prior to operation. Adjustments are provided on the light collecting mirror mount in the event that realignment becomes necessary.

Caution:

Read All Precautions Below and in the Manufacturer's Handling Precautions, and Become Aware of the Hazards Pertaining to Xenon Lamps Before Attempting to Handle them!

1. Handling Precautions: Xenon lamps are always under pressures above atmosphere, so use extreme care when handling, installing or mounting them to avoid any mechanical strains on the lamp. Protective glasses, heavy gloves and a mask should always be worn when handling xenon lamps. Mechanical strain can cause the lamp to shatter violently!
2. Contamination: Never touch the lamp with bare hands, as fingerprints or other contaminants left on the lamp during operation will cause permanent degradation to the lamp envelope. Contamination can cause the lamp to shatter violently!
3. Radiation Hazards: The XS-432 xenon light source should never be operated unless properly mounted to the entrance slit of an Acton series monochromator. The output spectra of xenon lamps contains high levels of short wavelength ultraviolet radiation, which can cause permanent damage to unprotected skin and eyes. Therefore, never look directly into the output beam, any diffuse reflection, or any specular (mirror) reflection even for a short period of time without suitable protective ultraviolet blocking filters or glasses. Never look into the exit slit of a monochromator when xenon or other

ultraviolet light sources are in operation. Even when a monochromator output is set to “non-ultraviolet” wavelengths, the output may contain “second order” or stray ultraviolet radiation.

4. Ozone Hazard: All xenon lamps, other than ozone free lamps, allow ozone gas to be generated while the lamp is in operation. Always provide for proper ventilation to remove this ozone. High concentrations of ozone are dangerous and can constitute a serious health hazard!
5. Other: Read manufacturers “Instructions for use of Xenon XBO”, attached, before attempting to install or operate this lamp.

Mounting:

For proper operation, the lamp housing must always be mounted to the entrance slit of the spectrometer and the lamp housing cover must always be in place.

To mount the lamp housing to the entrance slit, use the following procedure:

- A1. Locate the two (2) shoulder screws and the two (2) 8-32 cap screws supplied with the XS-432. Insert the shoulder screws into the two bottom outside tapped holes of the entrance slit of the spectrometer and tighten. These are used to mount the lamp housing.
- A2. Remove the four (4) slotted screws from the top of the lamp housing, then remove the cover.

Caution: Do not touch the surface of the focusing mirror.

- A3. Carefully slide the two (2) “key hole” type slots of the lamp housing mounting flange over the shoulder screws in the entrance slit of the spectrometer. Insure that the top two holes of the lamp housing mounting flange align properly with the top two tapped holes of the spectrometer entrance slit.
- A4. Insert the two (2) 8-23 cap screws in the top two holes of the lamp housing mounting flange and tighten.

A5. If the lamp is to be installed at this time, proceed to stop #B2 below. If not, replace the lap housing cover.

Installation of the Xenon Lamp in the Lamp Housing:

(Note: The lamp housing must be mounted to the entrance slit as described above)

CAUTION

Never touch the xenon lamp (bulb) or the surface of the focusing mirror. If the xenon lamp should become contaminated, refer to the manufacturer's handling precautions for proper cleaning procedure.

To initially install the xenon lamp in the lamp housing, use the following procedure.

- B1. Remove the four (4) screws from the lamp housing cover and remove the cover.
- B2. Locate the 1/16 and 7/64 Allen wrenches supplied.
- B3. A shipping post is installed in place of the lamp for shipping purposes. Inside the lamp housing, locate and become familiar with the shipping post, the top terminal, the mirror locations and the base terminal with a split clamp arrangement securing the shipping post.

Caution: Do not touch, talk or breathe on the mirrors.

- B4. Note the orientation of the top terminal, as the lamp and top terminal must be installed in the same orientation. Using the 1/16" Allen wrench, loosen the set screw in the end of the top. Note: Do not remove the wire from the top terminal. Remove the top terminal from the shipping post and set the terminal inside the lamp housing, adjacent to the mirror.
- B5. Insert the end of the 7/64" Allen wrench into the screw in the split clamp of the base terminal and loosen the screw. Remove the shipping post and save for future use.

B6. Locate the section at the end of this manual tabbed “Lamp OEM Instructions”. Read, become familiar with and follow the “Lamp OEM Instructions”.

B7. Locate the lamp shipping box. Put on a protective mask, goggles (glasses), and gloves and carefully remove the lamp from its shipping box. Do not remove the protective cover from the lamp at this time.

B8. Become familiar with the lamp, noting in particular the “+” and “—” terminals on each end of the lamp and the short black line on the “+” end. Also, look at the top terminal in the lamp housing and note the small pin protruding into the through hole in the top terminal. Insert the “+” terminal on the lamp into the top terminal in the lamp housing. Orient the lamp so that the clear part of the lamp envelope will face the source mounting flange when installed with the top terminal in the original orientation. While gently holding the lamp in the top terminal, securely hold the top terminal and tighten the terminal clamping screw in the top terminal using the Allen wrench provided. Caution: Do not over tighten the clamping screw.

Caution: Do not apply any pressure to the lamp when tightening the set screw! Do not over tighten the set screw.

B9. Very carefully remove the protective cover from the lamp. Gently insert the lamp (with the top terminal connected) into the split clamp in the base terminal until it rests on the small pin.

Caution: Do not apply any stress or strain to the lamp. Assure that the top terminal is oriented approximately as noted in step #B4.

B10. Tighten base terminal clamping screw using the Allen wrench provided until the lamp is secure.

Caution: Do not over tighten the clamping screw.

B11. Replace the top cover.

The xenon lamp is now properly installed.

Operation:

CAUTION

THE TOP COVER MUST BE IN PLACE BEFORE THE LAMP IS TURNED ON!

Connections for the XS-432

1. Connect the DC power cable between the XS-432 lamp housing and the Optiquip power supply.
2. Connect the line cord between the lamp housing fan and the outlet on the rear of the Optiquip power supply.
3. With the power switch on the Optiquip power supply switched off, plug its line cord into a 110 volt outlet.

To Turn Lamp On:

1. Turn on the switch on the Optiquip power supply to ignite the Xenon lamp. This may take several seconds depending on the age and temperature of the Xenon bulb.
2. The Optiquip power supply is preadjusted for a power of 75 watts to operate the Xenon lamp by Princeton Instruments. If the power is not 75 watts during operation, refer to the Optiquip power supply instruction manual.

WARNING

IF LOUD SNAPPING SOUNDS ARE HEARD FROM THE LAMP HOUSING OR POWER SUPPLY DURING IGNITION, TURN OFF THE POWER SUPPLY IMMEDIATELY AND CHECK ALL CABLE CONNECTIONS. FAINT CLICKING SOUNDS DURING IGNITION ARE NORMAL.

To Turn Lamp Off:

1. Turn off power switch on the Optiquip power supply.

Refer to the attached manufacturer's instruction manual for more details on operation of the power supply and lamp.

CAUTION

High Voltage Light Sources such as the XS-432 May Cause Interference with Computers and Microprocessors, Especially During start Up of the Lamp. The Light Source Should be Turned On Before Starting and Computers or Microprocessor Controlled Monochromators.

Lamp	Average life		Operating voltage (average value)	Operating current (rated value)	Current control range for stable operation ¹⁾	Permissible burning position	Forced air cooling required	Magnetic field required at horizontal operation
	horiz.	vert.						
Ordering abbreviation	hrs.	hrs.	V	amps	amps	-	-	-
XBO 75 W/1.../2	400	400	14	5,4	-	s 100	no	no
XBO 150 W/1	-	1200	20	7,5	-	s 15	no	-
XBO 150 W/S ²⁾	800	1000	20	7,5	-	s 15 p 15	yes	yes
XBO 150 W/GS	1000	1200	17,5	8,5	-	s 15 p 15	no	yes
XBO 250 W	-	1200	14	18	-	s 15	no	-
XBO 450 W.../2	-	2000	18	25	17... 30	s 30	no	-
XBO 450 W/1	800	800	18,5	25	17... 30	s 100	no	no
XBO 500 W/H	2000	2000	18	28	17... 30	s 30/p 30	yes	yes
XBO 700 W/HS	1500	1500	19	37	30... 45	s 20/p 20	yes	no
XBO 700 W/HSC	-	2000	20	45	30... 53	s 30	no	-
XBO 900 W	-	2000	20	45	30... 53	s 30	no	-
XBO 900 W/CA	-	2000	20	45	30... 53	s 30	no	-
XBO 1000 W/HS	1500	1500	20	50	30... 55	s 20/p 20	yes	no
XBO 1000 W/HSC	-	2000	22	45	30... 55	s 30/p 30	no ²⁾	yes
XBO 1000 W/HTP	-	2000	25	65	45... 75	s 30	no	-
XBO 1600 W	-	2000	25	65	45... 75	s 30	no	-
XBO 1600 W/CA	-	2000	25	65	45... 75	s 30	no	-
XBO 1600 W/HS	1500	1500	22	65	45... 70	s 20/p 20	yes	no
XBO 1600 W/HSC	-	2000	29	70	50... 85	s 30/p 30	no	yes
XBO 2000 W/H	2000	2000	29	70	50... 85	s 30/p 30	yes	yes
XBO 2000 W/HS	2000	2000	29	70	50... 85	s 30/p 30	yes	yes
XBO 2000 W/HTP	2000	2000	29	70	50... 85	s 30/p 30	no ²⁾	yes
XBO 2500 W	-	1500	30	83	60... 95	s 30	no	-
XBO 2500 W/HS	1200	1500	28	90	70... 100	s 30/p 20	yes	no
XBO 3000 W/H	1200	1500	30	100	60... 100	s 30/p 30	no	yes
XBO 3000 W/HS	1200	1500	30	100	60... 110	s 30/p 30	yes	yes
XBO 3000 W/HTP	1200	1500	30	100	60... 110	s 30/p 30	no ²⁾	yes
XBO 4000 W/HS	800	-	30	135	80... 150	s 20/p 20	yes	no
XBO 400 W/HTP	900	1200	31	130	100... 140	s 20/p 20	yes ²⁾	yes
XBO 4200 W/CA	-	500	30	140	60... 160	s 15	yes	-

¹⁾ Currents below the current control range will result in erratic lamp starting, and in a certain arc instability; with currents above the current control range, reliable operation can no longer be warranted.

²⁾ To avoid contact resistances, it is recommended to apply forced cooling to the bases of HTP lamps.

³⁾ At vertical operation, cooling fins on the anode base may be applied instead of forced cooling.

Wiring Diagram for XBO lamps (DC operation)

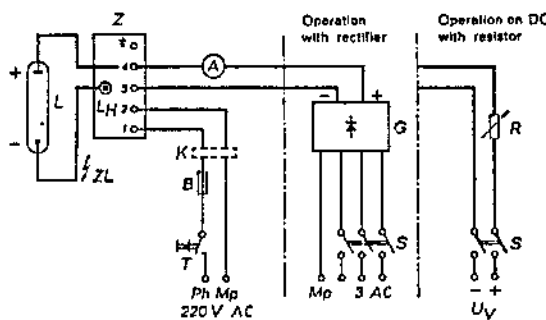

Fig. 1: XBO lamps with or without ignition electrode.

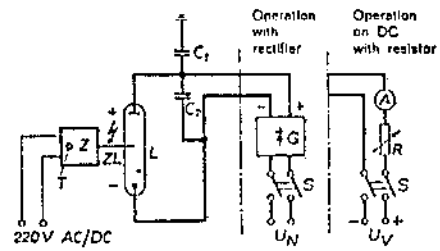
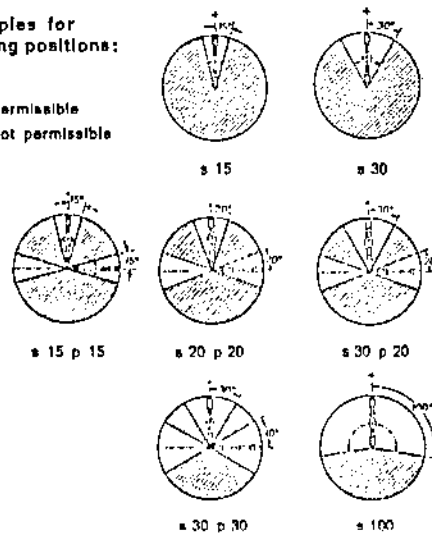

Fig. 2: XBO 75 W/1 with ignition device for 3-electrode lamps.

Examples for burning positions:

□ permissible
 ▨ not permissible



- A = Ammeter
- B = Slow blow fuse 6 amps
- C₁ = Grounding capacitor
2500 pfd non-inductive
- C₂ = Coupling capacitor
2500 pfd non-inductive
- G = Rectifier
- K = Short-time switch
- L = Lamp XBO
- L_H = High voltage terminal

- M_p = Neutral lead
- Ph = Phase lead
- R = Series resistor
- S = Switch
- T = Push-button
- U_N = Mains voltage 220 V AC
- U_v = Lamp supply voltage
- Z = Ignition device
- ZL = Ignition lead

Instructions for Use of Xenon Lamps XBO

When handling the lamp, please follow the instruction for operation of the equipment!

Insert lamp with protective cover in the lamp housing. Pay attention to the permissible burning position of the lamp. When inserting and connecting the lamp, no twisting or bending forces should be transferred to the lamp body. Make sure of a good fit of the current connectors. All flexible leads must be run with traction relief.

Before taking the protective cover off the lamp, put on a protective mask and leather gauntlets.

If the quartz body of the lamp was accidentally touched, clean it with alcohol and then with distilled water. Please wear protective mask and gauntlets when doing this job. Do not use cleaning rags but cotton wool or kleenex tissue to avoid damages to the surface of the quartz envelope.

When installing lamps XBO 700 W/HS, XBO 700 W/HSC, XBO 1000 W/HS, XBO 1000 W/HSC, XBO 1600 W/HS, and XBO 1600 W/HSC, the attached flat washer is to be fitted upon the threaded pin on the cathode side. Removal of the closefitting flat washer (after half the average lamp life) will allow a rotation of the lamp by exactly 180° (see also section 4. Maintenance of Lamp). When screwing the lamps into their cathode-side support, the protective cover may be used as a tool. For this purpose, the protective cover is provided with two recesses which are catching the two metal pins on the side of the cathode base.

After having inserted the lamp and connected the current leads, please check if there is enough play in direction of lamp axis. To avoid mechanical stresses, the lamp must be able to freely expand when warming-up during operation.

Before initial operation, polarity of the electric connection should be checked so as to avoid reversed polarity.

The lamp housing must be closed during ignition and operation of lamp. When an auxiliary mirror is used, it should be focussed correctly against the luminous arc (please observe instruction for operation of the equipment).

The current of these lamps may be varied within a certain range (as stated in the table) without causing a change in the spectrum of the radiation. The maximum current values as stated in the table should never be exceeded.

When operating lamps with forced cooling, care should be taken that the velocity of the cooling air stream is high enough. Therefore, in many cases an exhauster ventilation will be necessary in addition to the blower installed in the device. The base temperature should never exceed 230° C (regardless of operation with convection or forced cooling).

When running these lamps in horizontal position, the deflection of the luminous arc caused by the convective gas stream within the discharge vessel should be compensated for by an appropriately dimensioned magnetic field.

For reasons of safety, it is strongly recommended to replace the lamps at the latest after the average life stated in the catalog has been exceeded by 25 %.

Open main switch. Do not open lamp house until at least 10 minutes after switching-off the lamp. At operation with forced cooling, the blower should be kept running for at least 5 minutes after switching-off the lamp.

Please follow the instruction for operation of the equipment.

When working on the equipment while the lamp house is open, fit the protective cover around the lamp, and wear protective mask and gauntlets. Check the contact surfaces of lamp and connecting parts for cleanness at regular intervals. If need be, clean them. Contact resistances may lead to scorching of the bases and consequently to a premature failure of the lamp. If an auxiliary mirror is used, it should be carefully refocussed after the maintenance work is finished. Dust accumulating on the discharge vessel after several operating hours should be removed with a soft hair-brush.

Since at horizontal burning position the Xenon lamp will blacken on one side (upper part), it is to be rotated by 180° after half the average life. A flat washer is attached to lamps XBO 700 W/HS, XBO 700 W/HSC, XBO 1000 W/HS, XBO 1000 W/HSC, XBO 1600 W/HS, and XBO 1600 W/HSC which is to be removed from the threaded pin on the cathode side after half the average life. Re-screwing will result in a rotation of the lamp through 180°.

Fit the protective cover around the cooled-off lamp and follow the safety precautions as described under item 1.

Burnt-out lamps may either be returned to the lamp manufacturer in their protective cover and original package or be destroyed as follows: Wrap lamp without protective cover in a large, thick cloth (e.g. a new dry scrubbing cloth), put it on a hard underlay and smash it with a hammer. The safety precautions must be observed.

Mechanically destroyed lamps should be packed separately, i.e. not in the protective cover.

The warranty is covered by our Terms of Delivery.

Please note: The lamps are covered by a warranty only when the auxiliary equipment used meets the specifications established by the lamp manufacturer.

In the event of claims, please complete in detail the questionnaire accompanying each lamp and return it together with the rejected lamp to your supplier who will pass it on to the lamp manufacturer. No liability is accepted for XBO lamps which became unusable due to in-expert handling, particularly non-observance of these instructions, or due to damage during transport.

1. Installation of Lamp

XBO 700 W/HS, 700 W/HSC
XBO 1000 W/HS, 1000 W/HSC
XBO 1600 W/HS, 1600 W/HSC

2. Operation of Lamp

XBO 150 W/S, 150 W/GS
XBO 500 W/H, 2000 W/H
XBO 3000 W/H
XBO 1000 W/HTP, 2000 W/HTP
XBO 3000 W/HTP, 4000 W/HTP
XBO 2000 W/HS, 3000 W/HS

3. Switching-off the Lamp

4. Maintenance of Lamp

horizontal burning position

5. Removal of Lamp

6. Burnt-out Lamps

7. Warranty

THIS DRAWING REMAINS THE PROPERTY OF ACTON RESEARCH CORPORATION AND CONTAINS PROPRIETARY INFORMATION WHICH SHALL NOT BE REPRODUCED OR DISCLOSED WITHOUT WRITTEN AUTHORIZATION

REV.	DESCRIPTION	DATE
1	WAS DWG # 8401-011-21 (DUP #)	LEA 6-10-93
2	REVISED SEE RECORD PRINT # 30581	KRA 1-17-94
3	WAS 5 $\frac{3}{4}$, ADDED "MODIFIED"	KRA 5-11-94

WIRE LENGTHS: (SEE NOTES #6 & 7)

- LAMP SOCKET LEAD (PIN #7)
- LAMP SOCKET LEAD (PIN #10)
- GROUND (PIN #3)
- FAN LEADS (PINS 1 & 2)
- FAN JUMPER (PIN 4)

6 $\frac{3}{4}$ "
4 $\frac{1}{4}$ "
3"
4"
2"

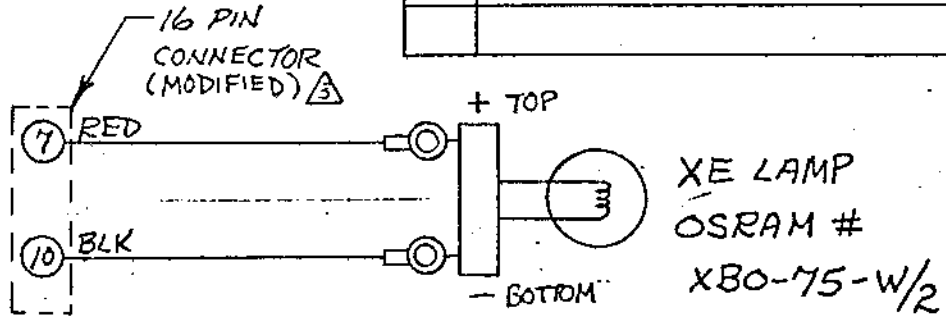

NOTES:

1. COLOR CODING IS TYPICAL & FOR REFERENCE ONLY
2. NUMBERS REFER TO PIN #'S IN 16 PIN CONNECTOR AMP # 206036-1
3. USE MALE PINS IN 4 & 16 PIN CONNECTORS AMP # 66103-2 M-SERIES CONTACT
4. USE CRIMP ON RING LUG FOR $\frac{1}{2}$ & LAMP SOCKET CONNECTIONS
5. USE FEMALE QUICK DISCONNECT ON FAN LEAD CONNECTIONS AMP # 2-520084-2 "FASTON"

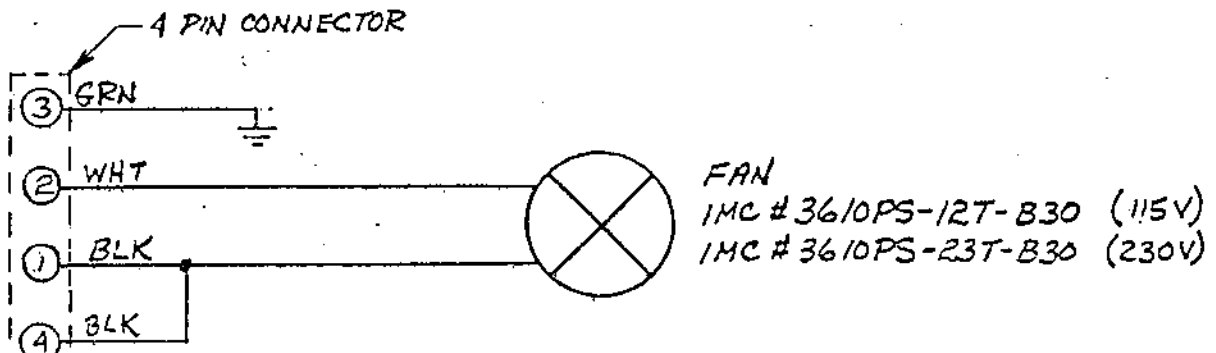

6. USE 20 AWG STRANDED WIRE FOR CONNECTIONS TO $\frac{1}{2}$ & FAN
7. USE BELDAN # 9867 20 AWG HIGH VOLTAGE WIRE TO LAMP PINS 7 & 10

UNLESS OTHERWISE SPECIFIED		MATERIAL AS SPEC		FINISH	
DIMENSIONS ARE IN INCHES				DRAWN BY KRA	
TOLERANCE ON					
FRACTIONS	DECIMALS	ANGLES	SCALE: \times	QTY 1	
$\pm \frac{1}{16}$.xx \pm .010	\pm 15 MIN	DATE: 4-5-91	NEXT ASS'Y	
	.xxx \pm .005		ACTON RESEARCH CORPORATION		BOX 215/525 MAIN ST. ACTON, MA 01720
MACH. SURFACE 32- MAX. REMOVE ALL BURRS & BREAK SHARP EDGES .010R. MAX.					
DWG. TITLE		SIZE	DWG. NO.	REV.	
XE SOURCE SCHEMATIC		A	8401-011-23 Δ	3	