

NOTE:  
Please read all instructions  
carefully before using this  
product

Table of Contents

Safety Notice

Hardware Identifier

Assembly Instruction

Parts List

Warranty

Ordering Parts

Model  
MWB 760

Retain This  
Manual for  
Reference

03-10-04

OWNER'S  
MANUAL

**IMPEX**  
FITNESS PRODUCTS

**MARCY BENCH**

**MWB-760**

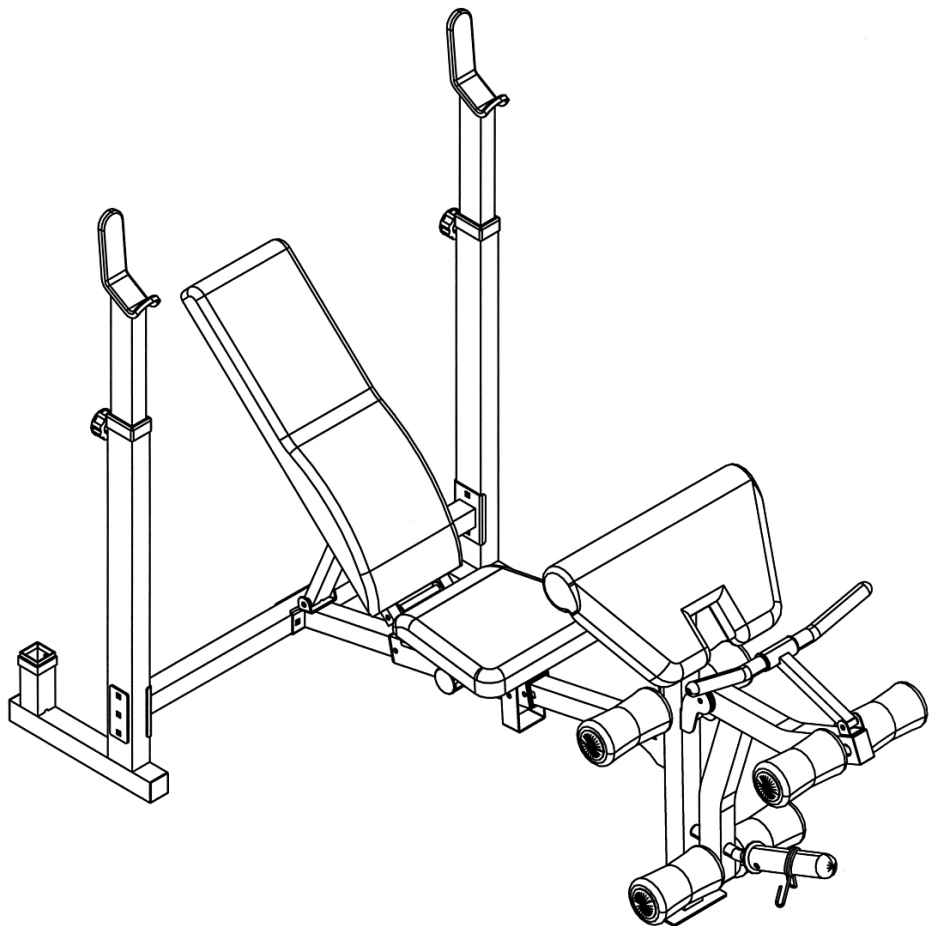

**IMPEX FITNESS PRODUCTS**

14777 DON JULIAN RD., CITY OF INDUSTRY, CA 91746

Tel: (800) 999-8899 Fax: (626) 961-9966

[www.impex-fitness.com](http://www.impex-fitness.com)

[info@impex-fitness.com](mailto:info@impex-fitness.com)

---

## TABLE OF CONTENTS

BEFORE YOU BEGIN.....	1
IMPORTANT SAFETY NOTICE.....	2
HARDWARE PACK.....	3
ASSEMBLY INSTRUCTIONS.....	4
EXPLODED DIAGRAM.....	9
PARTS LIST.....	10
WARRANTY.....	11
ORDERING PARTS.....	11

---

## BEFORE YOU BEGIN

Thank you for selecting the MARCY Bench MWB 760 by IMPEX FITNESS PRODUCTS. For your safety and benefit, read this manual carefully before using the machine. As a manufacturer, we are committed to provide you complete customer satisfaction. If you have any questions, or find there are missing or damaged parts, we guarantee you complete satisfaction through direct assistance from our factory. To avoid unnecessary delays, *please call our TOLL-FREE customer service number.* Our Customer Service Agents will provide immediate assistance to you.

**Toll-Free Customer Service Number**

**1-800-999-8899**

**Mon. - Fri. 9 a.m. - 5 p.m. PST**

**[www.impex-fitness.com](http://www.impex-fitness.com)**

**[info@impex-fitness.com](mailto:info@impex-fitness.com)**

## **IMPORTANT SAFETY NOTICE**

### **PRECAUTIONS**

This exercise machine is built for optimum safety. However, certain precautions apply whenever you operate a piece of exercise equipment. Be sure to read the entire manual before you assemble or operate your machine. In particular, note the following safety precautions:

1. **Keep children and pets away from the machine at all times. DO NOT leave children unattended in the same room with the machine.**
2. Only one person at a time should use the machine.
3. If the user experiences dizziness, nausea, chest pain, or any other abnormal symptoms, STOP the workout at once. CONSULT A PHYSICIAN IMMEDIATELY.
4. Position the machine on a clear, leveled surface. DO NOT use the machine near water or outdoors.
5. Keep hands away from all moving parts.
6. Always wear appropriate workout clothing when exercising. DO NOT wear robes or other clothing that could become caught in the machine. Running or aerobic shoes are also required when using the machine.
7. Use the machine only for its intended use as described in this manual. DO NOT use attachments not recommended by the manufacturer.
8. Do not place any sharp object around the machine.
9. Disabled person should not use the machine without a qualified person or physician in attendance.
10. Before using the machine to exercise, always do stretching exercises to properly warm up.
11. Never operate the machine if the machine is not functioning properly.
12. A spotter is recommended during exercise.

**WARNING: BEFORE BEGINNING ANY EXERCISE PROGRAM, CONSULT YOUR PHYSICIAN. THIS IS ESPECIALLY IMPORTANT FOR INDIVIDUALS OVER THE AGE OF 35 OR PERSONS WITH PRE-EXISTING HEALTH PROBLEMS. READ ALL INSTRUCTIONS BEFORE USING ANY FITNESS EQUIPMENT. IMPEX INC. ASSUMES NO RESPONSIBILITY FOR PERSONAL INJURY OR PROPERTY DAMAGE SUSTAINED BY OR THROUGH THE USE OF THIS PRODUCT.**

**SAVE THESE INSTRUCTIONS.**

# HARDWARE PACK

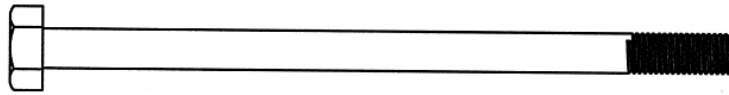

#42 M10 x 7 1/4" Hex Bolt (Qty 2)

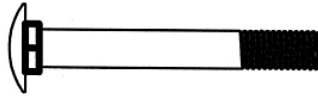

#43 M10 x 2 3/4" Carriage Bolt (Qty 4)

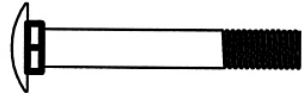

#38 M10 x 2 1/2" Carriage Bolt (Qty 4)

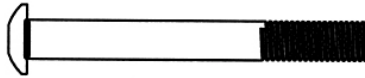

#44 M10 x 3 3/8" Allen Bolt (Qty 1)

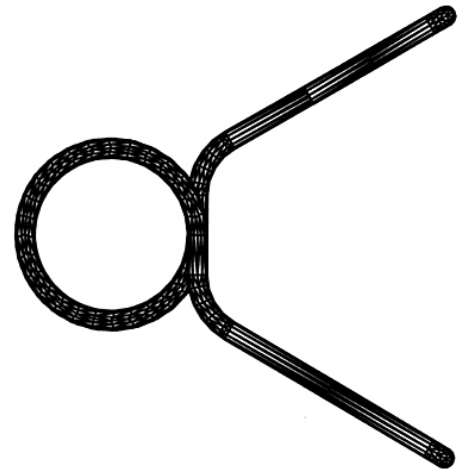

#34 Spring Clip (Qty 1)



#37 M8 x 1 5/8" Allen Bolt (Qty 4)



#35 M8 x 3/4" Allen Bolt (Qty 6)



#41 M10 x 5/8" Allen Bolt (Qty 2)



#53 Ø 3/4" x 3/8" Bushing (Qty 2)



#27 Axle (Qty 1)

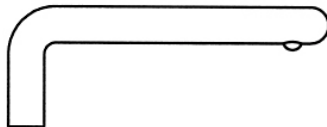

#30 3" L-shaped Lock Pin (Qty 1)

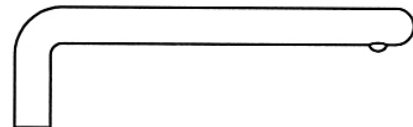

#29 4" L-shaped Lock Pin (Qty 1)



#39 Ø 3/4" Washer (Qty 16)



#36 Ø 5/8" Washer (Qty 10)



#40 M10 Aircraft Nut (Qty 11)



# ASSEMBLY INSTRUCTION

**Tools Required Assembling the Machine: Two Adjustable Wrenches and Allen Wrenches**

**NOTE: It is strongly recommended two or more people assembling this machine to avoid possible injury.**

## STEP 1 (See Diagram 1)

- A.) Connect the Left Upright Beam (#1) and Right Upright Beam (#2) by a Cross Brace (#3) in the mid-span. Align the holes and secure each end of the Cross Brace with two M10 x 2 3/4" Carriage Bolts (#43), one 4 3/4" x 2" Bracket (#22), two Ø 3/4" Washers (#39), and two M10 Aircraft Nuts (#40).
- B.) Insert two Crutches (#7) into the top openings on the Upright Beams. Secure them with two Lock Knobs (#23) through selected holes to obtain desired height of the Supports.
- C.) Slide one Olympic Sleeve (#54) onto the weight post on Left Upright Beam (#1).

**DIAGRAM 1**

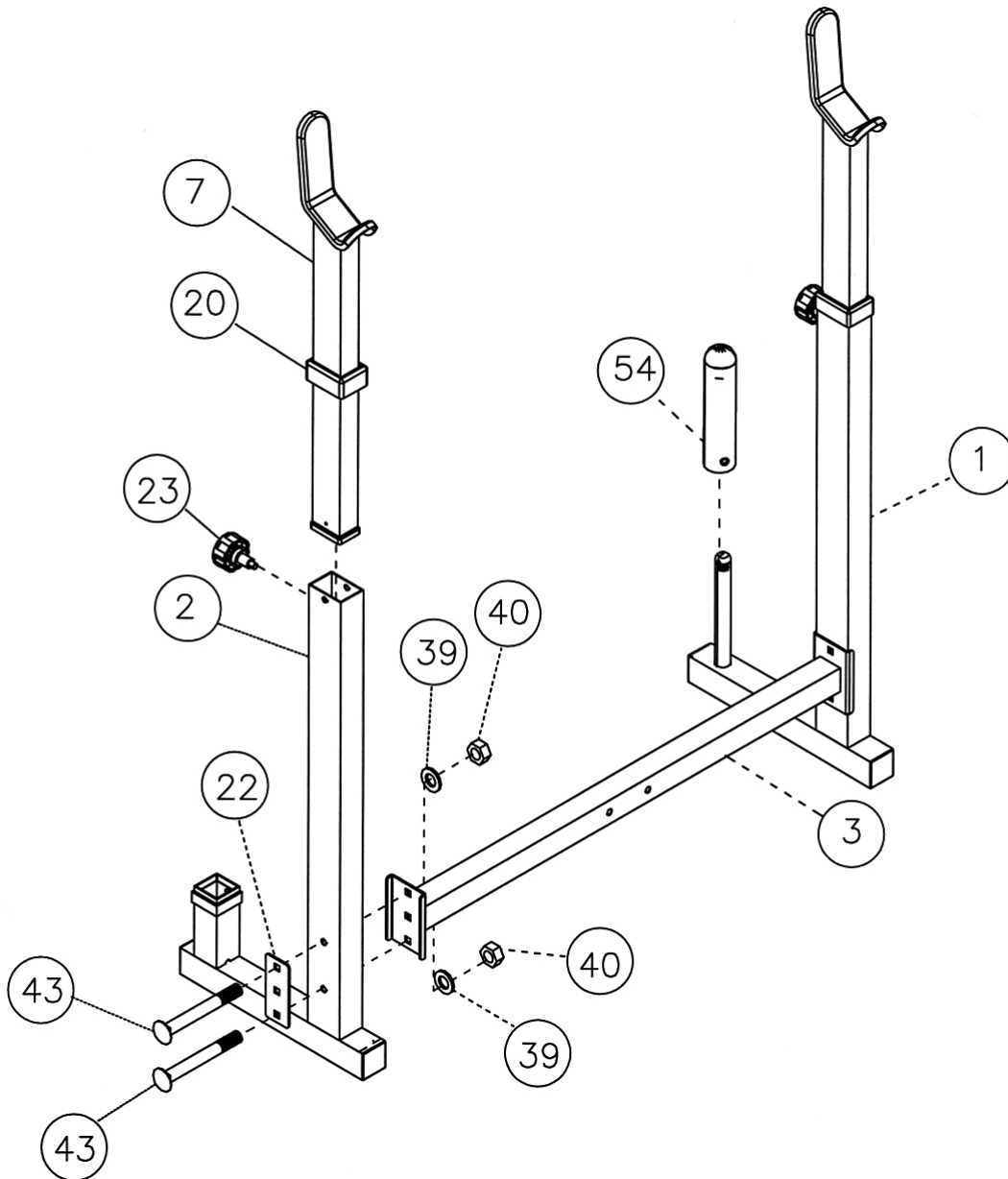

## STEP 2 (See Diagram 2)

- A.) Slide the Sliding Block (#5) onto the Main Seat Support (#4). Align the holes and secure it with a Lock Knob (#23).
- B.) Attach the Main Seat Support to the Cross Brace (#3). Secure it with two M10 x 2 1/2" Carriage Bolts (#38), one 4 3/8" x 1 3/4" Bracket (#24), two Ø 3/4" Washers (#39), and two M10 Aircraft Nuts (#40).
- C.) Attach the Leg Developer Holder (#8) to the Main Seat Support (#4). Secure it with two M10 x 2 1/2" Carriage Bolts (#38), two Ø 3/4" Washers (#39) and M10 Aircraft Nuts (#40). Attach a Lock Knob (#23) to the hole on the Leg Developer Holder.
- D.) Attach the Leg Developer (#9) to the open bracket on the Leg Developer Holder. Align the holes and secure it with an Axle (#27), two M10 x 5/8" Allen Bolts (#41), and two Ø 3/4" Washers (#39).
- E.) Attach an Olympic Sleeve (#54) Spring Clip (#34) to the weight post on the Leg Developer. Attach a Spring Clip (#34) to the Sleeve.
- F.) Attach the Curl Bar Handle Support (#13) to the open bracket on the Leg Developer. Lock it with a 3" L-shaped Lock Pin (#30) for Arm Curl exercise. Remove the Pin when using the Leg Developer.

### DIAGRAM 2

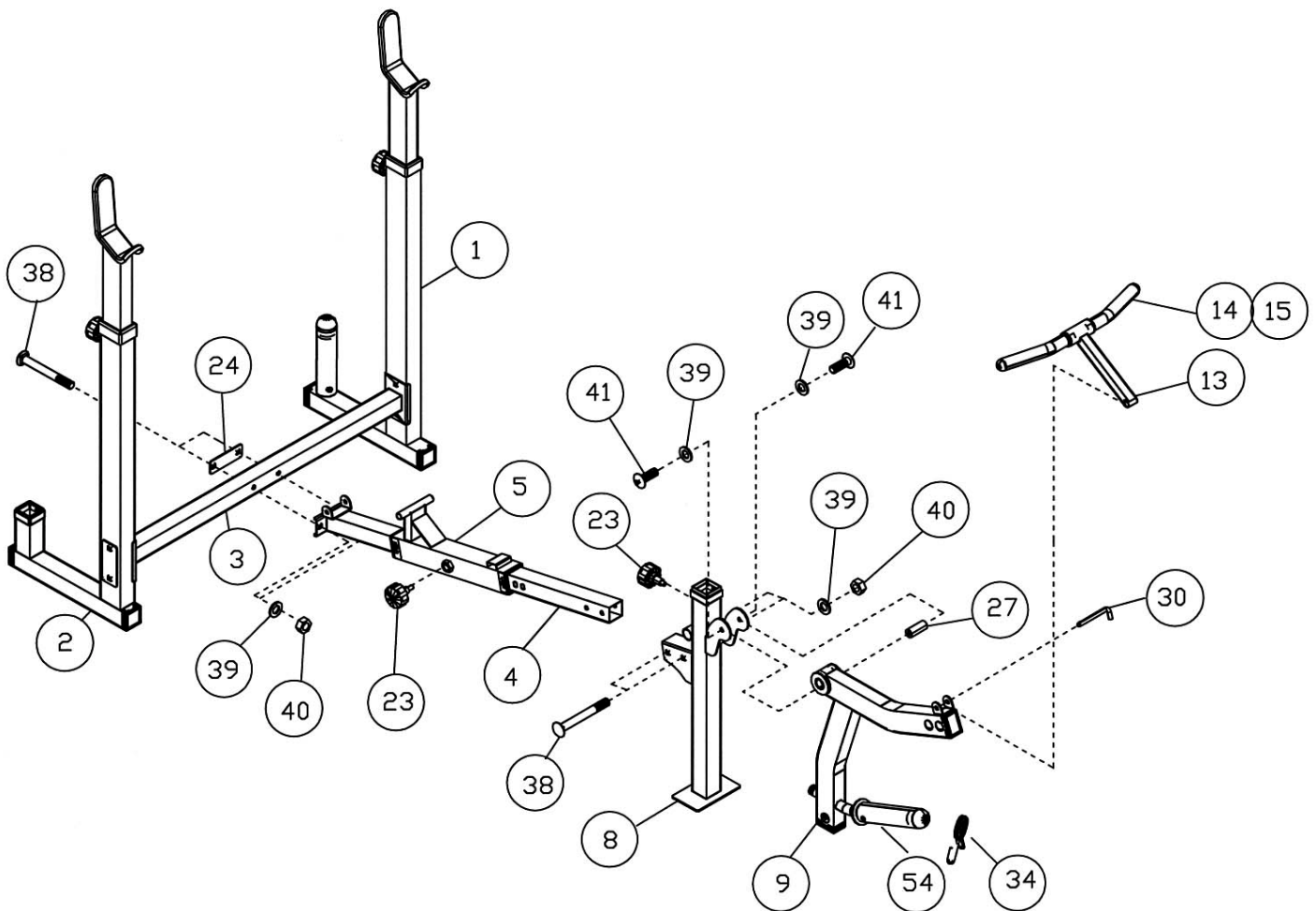

### STEP 3 (See Diagram 3)

- A.) Attach the Seat Bracket (#6) to the pivot on the Sliding Block (#5). Push two  $\text{Ø } \frac{3}{4}$ " x  $\frac{3}{8}$ " Bushings (#53) through the holes on the Seat Bracket into both ends of the pivot.
- B.) Attach the Backrest Supports (#12) to the Bushings. Secure it with one M10 x  $7 \frac{1}{4}$ " Hex Bolt (#42), two  $\text{Ø } \frac{3}{4}$ " Washers (#39), and one M10 Aircraft Nut (#40).
- C.) Attach the Backrest Incline Support (#11) to the Backrest Supports (#12). Secure it with a M10 x  $7 \frac{1}{4}$ " Hex Bolt (#42), two  $\text{Ø } \frac{3}{4}$ " Washers (#39), and one M10 Aircraft Nut (#40).
- D.) Attach the other end of Backrest Incline Support (#11) to the open bracket on the Main Seat Support (#4). Secure it with one M10 x  $3 \frac{3}{8}$ " Allen Bolt (#44), two  $\text{Ø } \frac{3}{4}$ " Washers (#39), and one M10 Aircraft Nut (#40).
- E.) Use the Sliding Block to select desired Backrest Incline position. NOTE: Do not over tighten the Bolts and Nuts. Make sure the Backrest Supports are able to incline.

**DIAGRAM 3**

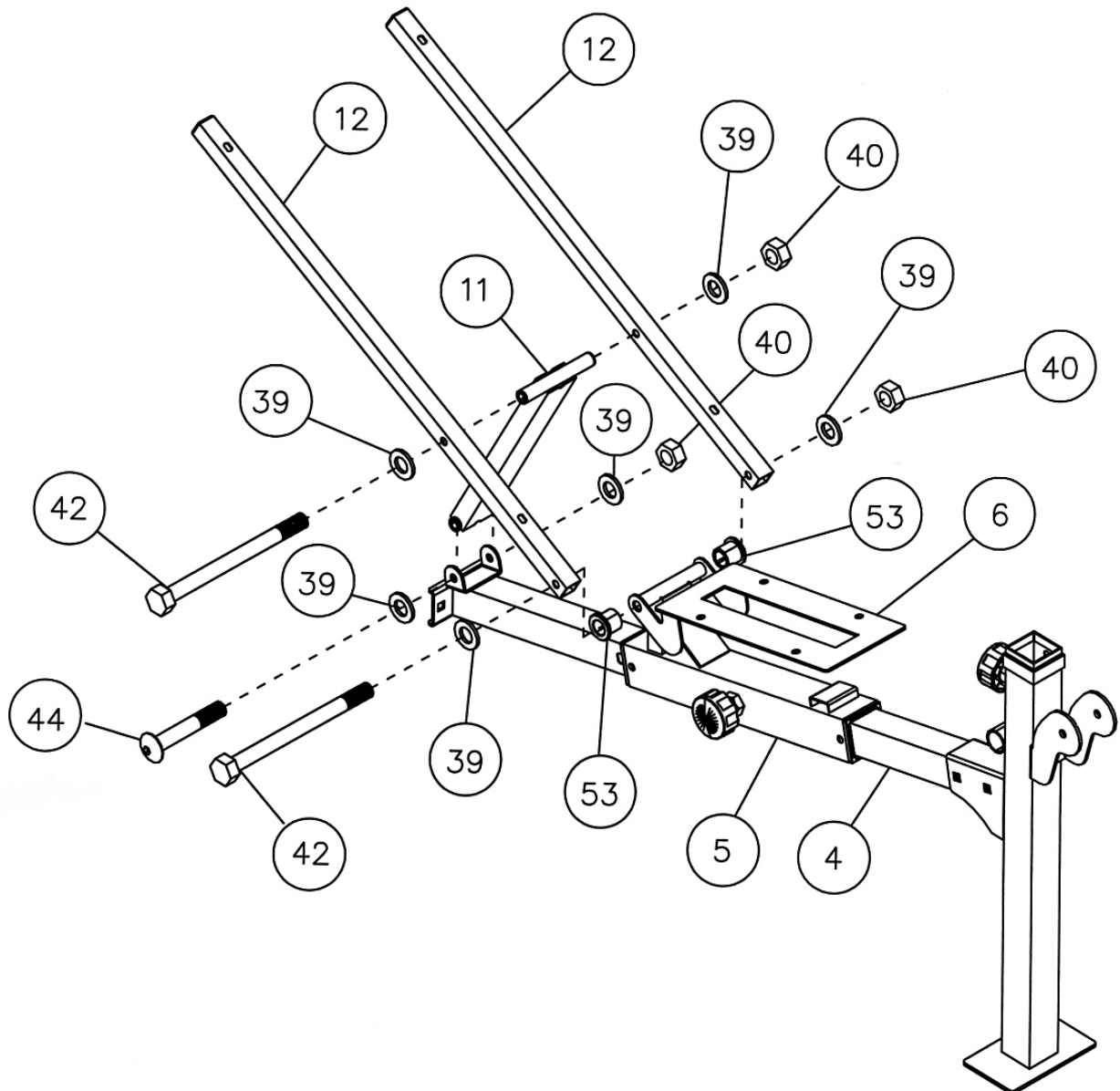

#### STEP 4 (See Diagram 4)

- A.) Attach the Seat Incline Adjustment (#19) to the two front holes on the bottom of Seat Bracket (#6). Place the Seat (#18) onto the Seat Bracket. Align the holes and secure it with four M8 x  $\frac{3}{4}$ " Allen Bolts (#35) and four  $\varnothing$  5/8" Washers (#36). Secure the position of the Incline Adjustment with a 4" L-Shaped Pin (#29).
- B.) Place the Backrest Board (#17) onto the Backrest Supports (#12). Secure it with four M8 x 1 5/8" Allen Bolts (#37) and  $\varnothing$  5/8" Washers (#36).
- C.) Attach the Arm Curl Pad (#16) to the Arm Curl Stand (#10). Secure it with two M8 x  $\frac{3}{4}$ " Allen Bolts (#35) and  $\varnothing$  5/8" Washers (#36).
- D.) Insert the Arm Curl Stand into the front opening on the Leg Developer Holder for Arm Curl exercises. Use the Lock Knob on the Leg Developer Holder to secure the position. When using the Leg Developer, remove the Arm Curl Stand and store it to the post on the base of Right Upright Beam.

**DIAGRAM 4**

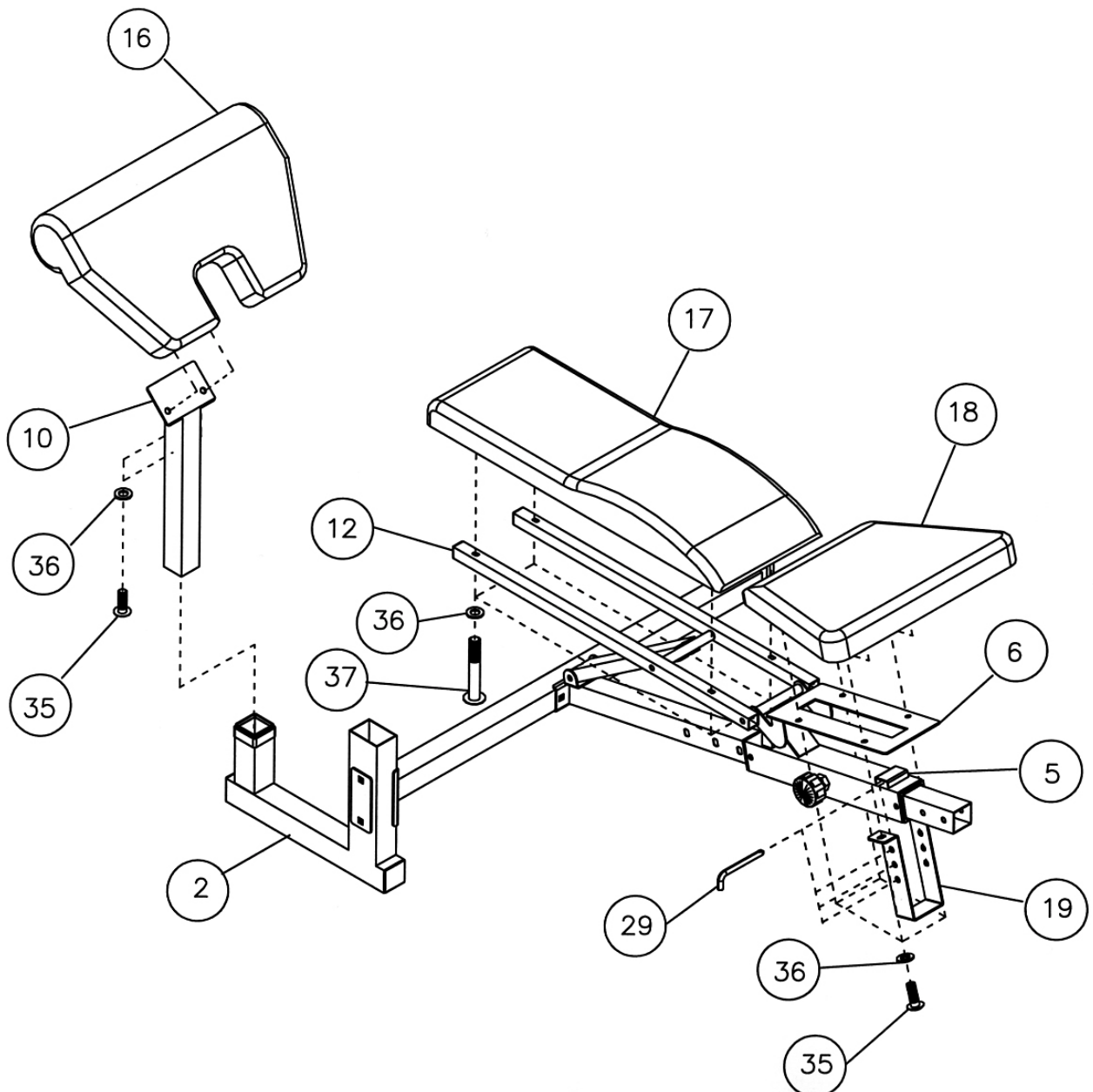



**STEP 5 (See Diagram 5)**

- A.) Insert one Foam Tube (#31) halfway through the hole on the Leg Developer Holder (#8). Insert two Foam Tubes (#31) halfway through the holes on the Leg Developer (#9).
- B.) Push six Foam Rolls (#32) onto the Tubes from both ends. Plug six Foam Roll End Caps (#33) into the ends.

**DIAGRAM 5**

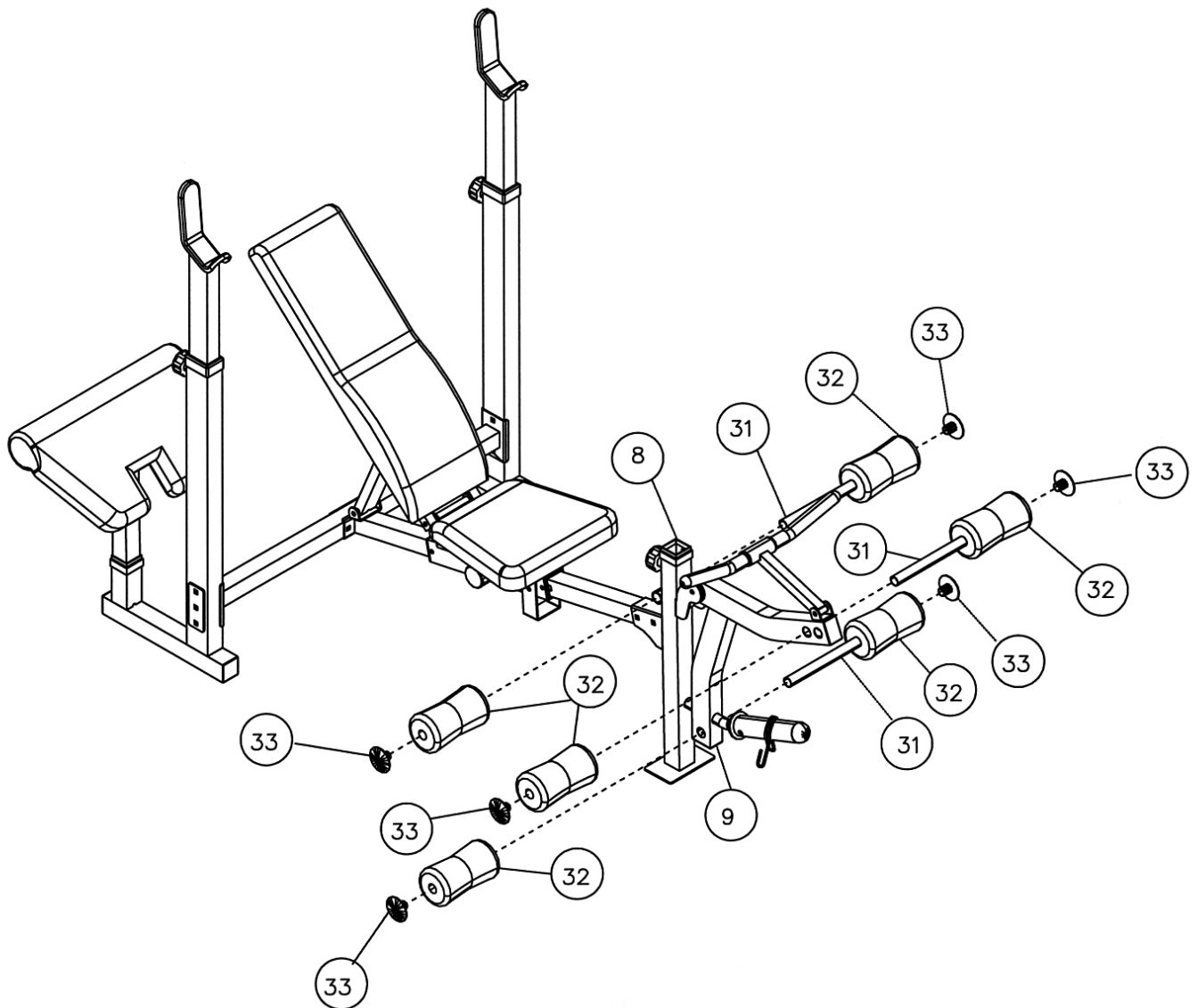

# EXPLODED DIAGRAM

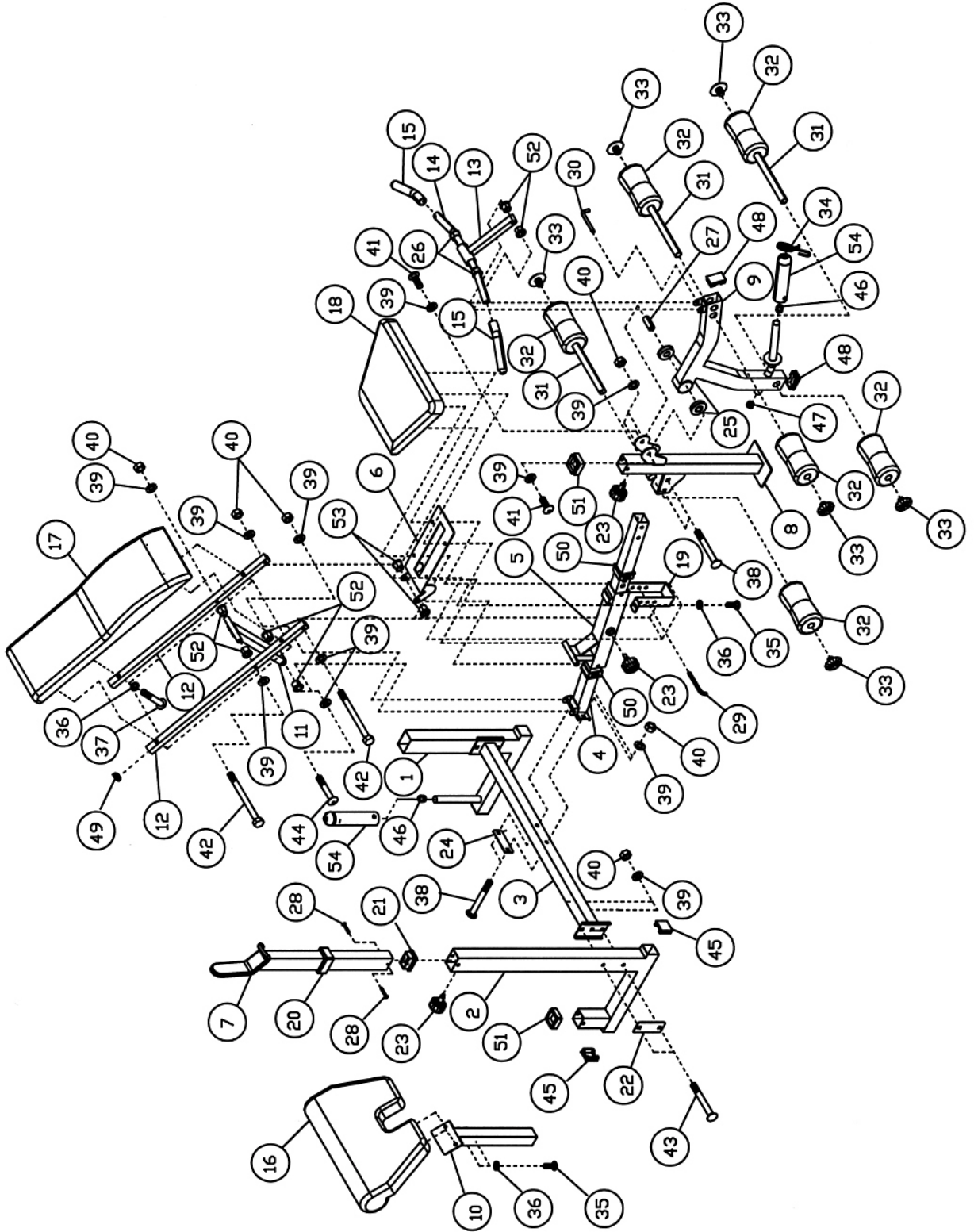

**PARTS LIST**

<b>KEY NO.</b>	<b>DESCRIPTION</b>	<b>Q'ty</b>
1	Left Upright Beam	1
2	Right Upright Beam	1
3	Cross Brace	1
4	Main Seat Support	1
5	Sliding Block	1
6	Seat Bracket	1
7	Crutch	2
8	Leg Developer Holder	1
9	Leg Developer	1
10	Arm Curl Stand	1
11	Backrest Incline Support	1
12	Backrest Support	2
13	Curl Bar Handle Support	1
14	Curl Bar Handle	1
15	Grip	2
16	Arm Curl Pad	1
17	Backrest Board	1
18	Seat	1
19	Seat Incline Adjustment	1
20	Crutch Sliding Sleeve	2
21	Crutch End Cap	2
22	4 3/4" x 2" Bracket	2
23	Lock Knob	4
24	4 3/8" x 1 3/4" Bracket	1
25	Ø 2 3/8" Bushing	2
26	Ø 1 1/2" Bushing	2
27	Axle	1
28	Philips Screw	4
29	4" L-shaped Lock Pin	1
30	3" L-shaped Lock Pin	1
31	Foam Tube	3
32	Foam Roll	6
33	Foam Roll End Cap	6
34	Spring Clip	1
35	M8 x 3/4" Allen Bolt	6
36	Ø 5/8" Washer	10
37	M8 x 1 5/8" Allen Bolt	4
38	M10 x 2 1/2" Carriage Bolt	4
39	Ø 3/4" Washer	16
40	M10 Aircraft Nut	11
41	M10 x 5/8" Allen Bolt	2
42	M10 x 7 1/4" Hex Bolt	2
43	M10 x 2 3/4" Carriage Bolt	4
44	M10 x 3 3/8" Allen Bolt	1
45	2" Square End Cap	4
46	Ø 1" Cone-shaped End Cap	2
47	Ø 1" End Cap	1
48	1 5/8" x 2 3/8" End Cap	2
49	1" Square End Cap	2
50	2 3/8" Block Sleeve	2
51	2" Sleeve	2
52	Ø 3/4" x 1/2" Bushing	6
53	Ø 3/4" x 3/8" Bushing	2
54	Olympic Sleeve	2
	#4 Allen Wrench (Tool)	1
	#5 Allen Wrench (Tool)	1
	#6 Allen Wrench (Tool)	2

# ***IMPEX INC.***

## **LIMITED WARRANTY**

IMPEX Inc. ("IMPEX") warrants this product to be free from defects in workmanship and material, under normal use and service conditions, for a period of two years on the Frame from the date of purchase. This warranty extends only to the original purchaser. IMPEX's obligation under this Warranty is limited to replacing or repairing, at IMPEX's option.

All returns must be pre-authorized by IMPEX. Pre-authorization may be obtained by calling IMPEX Customer Service Department at 1-800-999-8899. All freights on products returned to IMPEX must be prepaid by the customer. This warranty does not extend to any product or damage to a product caused by or attributable to freight damage, abuse, misuse, improper or abnormal usage or repairs not provided by an IMPEX authorized service center or for products used for commercial or rental purposes. No other warranty beyond that specifically set forth above is authorized by IMPEX.

IMPEX is not responsible or liable for indirect, special or consequential damages arising out of or in connection with the use or performance of the product or other damages with respect to any economic loss, loss of property, loss of revenues or profits, loss of enjoyments or use, costs of removal, installation or other consequential damages or whatsoever natures. Some states do not allow the exclusion or limitation of incidental or consequential damages. Accordingly, the above limitation may not apply to you.

The warranty extended hereunder is in lieu of any and all other warranties and any implied warranties of merchantability or fitness for a particular purpose is limited in its scope and duration to the terms set forth herein. Some states do not allow limitations on how long an implied warranty lasts. Accordingly, the above limitation may not apply to you.

This warranty gives you specific legal right. You may also have other rights which vary from state to state. Register on-line at [www.impex-fitness.com](http://www.impex-fitness.com)

**IMPEX INC.  
14777 Don Julian  
City of Industry, CA 91746**

### **ORDERING REPLACEMENT PARTS**

Replacement parts can be ordered by calling our Customer Service Department toll-free at **1-800-999-8899** during our regular business hours: Monday through Friday, 9 am until 5 pm Pacific standard time.

**[info@impex-fitness.com](mailto:info@impex-fitness.com)**

When ordering replacement parts, always give the following information.

1. Model
2. Description of Parts
3. Part Number
4. Date of Purchase