

OPERATING INSTRUCTIONS



RV-4060R

AUDIO/VIDEO RECEIVER

INTRODUCTION

UNPACKING AND INSTALLATION

Congratulations on Your Purchase!

Your new high fidelity Receiver is designed to deliver maximum enjoyment and years of trouble free service. Please take a few moments to read this manual thoroughly. It will explain the features and operation of your unit and help ensure a trouble free installation.

Please unpack your unit carefully. We recommend that you save the carton and packing material. They will be helpful if you ever need to move your unit and may be required if you ever need to return it for service. Your unit is designed to be placed in a horizontal position and it is important to allow at least two inches of space behind your unit for adequate ventilation and cabling convenience.

To avoid early damage, never place the unit near radiators, in front of heating vents, in direct sunlight, or in excessively humid or dusty locations. Connect your complementary components as illustrated in the following section.



CAUTION

RISK OF ELECTRIC SHOCK
DO NOT OPEN



CAUTION : TO REDUCE THE RISK OF ELECTRIC SHOCK, DO NOT REMOVE COVER (OR BACK). NO USER-SERVICEABLE PARTS INSIDE. REFER SERVICING TO QUALIFIED SERVICE PERSONNEL.



This symbol is intended to alert the user to the presence of uninsulated "dangerous voltage" within the product's enclosure that may be of sufficient magnitude to constitute a risk of electric shock to persons.



This symbol is intended to alert the user to the presence of important operating and maintenance (servicing) instructions in the literature accompanying the appliance.

WARNING

To reduce the risk of fire or electric shock, do not expose this appliance to rain or moisture.

Caution : Do not block ventilation openings or stack other equipment on the top.

FOR U.S.A.

■ **Note to CATV System Installer:** This reminder is provided to call the CATV system installer's attention to Article 820-40 of the NEC that provides guidelines for proper grounding and, in particular, specifies that the cable ground shall be connected to the grounding system of the building, as close to the point of cable entry as practical.

■ **FCC INFORMATION**

This equipment has been tested and found to comply with the limits for a Class B digital device, pursuant to Part 15 of the FCC Rules. These limits are designed to provide reasonable protection against harmful interference in a residential installation. This equipment generates, uses and can radiate radio frequency energy and, if not installed and used in accordance with the instructions, may cause harmful interference to radio communications. However, there is no guarantee that interference will not occur in a particular installation. If this equipment does cause harmful interference to radio or television reception, which can be determined by turning the equipment off and on, the user is encouraged to try to correct the interference by one or more of the following measures:

- Reorient or relocate the receiving antenna.
- Increase the separation between the equipment and receiver.
- Connect the equipment into an outlet on a circuit different from that to which the receiver is connected.
- Consult the dealer or an experienced radio TV technician for help.

CAUTION: Any changes or modifications in construction of this device which are not expressly approved by the party responsible for compliance could void the user's authority to operate the equipment.

READ THIS BEFORE OPERATING YOUR UNIT

FOR U.S.A. AND CANADA 120 V

FOR YOUR SAFETY

Units shipped to the U.S.A. and Canada are designed for operation on 120 V AC only.

Safety precaution with use of a polarized AC plug. However, some products may be supplied with a nonpolarized plug.

CAUTION : To prevent electric shock, match wide blade of plug to wide slot, fully insert.

ATTENTION : Pour éviter les choc électriques, introduire la lame la plug large de la borne correspondante de la prise et pousser

FOR AUSTRALIA AND EUROPE 230 V/240 V

FOR YOUR SAFETY

Units shipped to Australia are designed for operation on 240 V AC only.

To ensure safe operation, the three-pin plug supplied must be inserted only into a standard three-pin power point which is effectively earthed through the normal household wiring. Extension cords used with the equipment must be three-core and be correctly wired to provide connection to earth. Improper extension cords are a major cause of fatalities. The fact that the equipment operates satisfactorily does not imply that the power point is earthed and that the installation is completely safe. For your safety, if in any doubt about the effective earthing of the power point, consult a qualified electrician.

PAN-EUROPEAN UNIFIED VOLTAGE
All units are suitable for use on supplies 230-240 V AC.

FOR OTHER COUNTRIES 110 V/220 V

FOR YOUR SAFETY

Units shipped to countries other than the above countries are equipped with an AC voltage selector switch on the rear panel. Refer to the following paragraph for the proper setting of this switch.

AC VOLTAGE SELECTION

This unit operates on 110-220 V AC. The AC voltage selector switch on the rear panel is set to the voltage that prevails in the area to which the unit is shipped. Before connecting the power cord to your AC outlet, make sure that the setting position of this switch matches your line voltage. If not, it must be set to your voltage in accordance with the following direction.

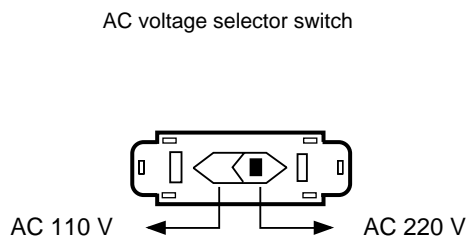

Move switch lever to match your line voltage with a small screwdriver or other pointed tool.

Please make the following connections (where applicable).

Notes!

- **SWITCH OFF THE RECEIVER BEFORE MAKING ANY CONNECTIONS.**
- Do not connect the receiver to the wall socket when making connections.
- Be sure to connect the white plugs to the L (left) and the red plugs to the R (right) jacks when making connections.

Important note for connecting equipment that does not have IN/OUT markings on the input and output jacks:

RV -4060R	Device to be connected e.g. cassette deck.
PLAY →	PLAY or OUT
REC →	REC or IN

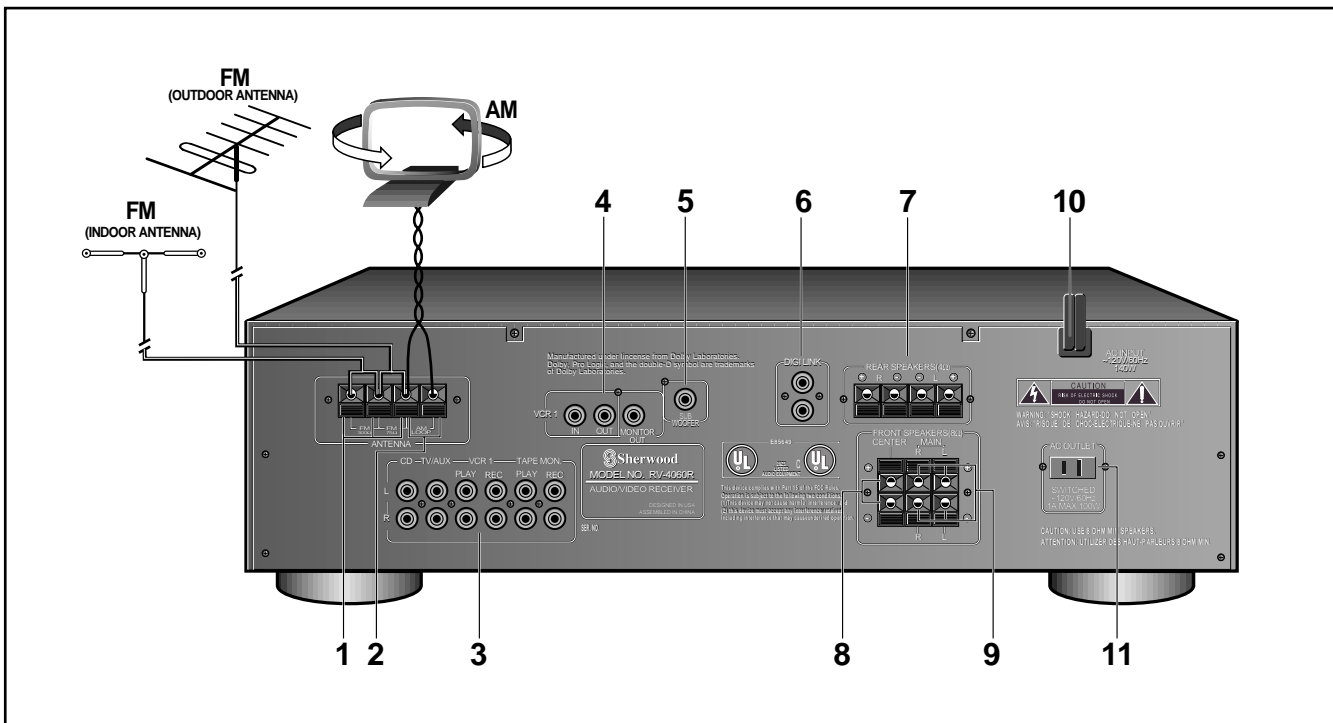

CONNECTIONS

1. FM INDOOR ANTENNA

Connect the supplied antenna to the FM antenna terminals, as shown. Change the position of the antenna until you get the best reception of your favorite FM stations.

FM OUTDOOR ANTENNA

A 75Ω outdoor FM antenna may be used to further improve the reception. Disconnect the indoor antenna before replacing it with the outdoor one.

2. AM LOOP ANTENNA

Tune in your favorite AM station and position the loop antenna for best reception. Try other stations and find the position that gives best overall reception. When this unit is mounted in a rack or placed on a shelf with insufficient space behind, hang the antenna on a wall in the direction which gives best reception.

3. AUDIO IN/OUT

- **CD IN** – input jacks for connecting a Compact Disc player.
 - Connect these jacks to the OUTPUT jacks of the CD player.
- **TV/AUX IN** – input jacks for connecting the fixed audio output jacks of a TV set or any other source you want to hear; an additional CD player, a cassette deck, a VCR or a turntable with ceramic cartridge, etc.

- **VCR 1 PLAY/REC** – PLAY(input) and REC(output) jacks for connecting the audio OUTPUT and INPUT jacks of a Hi-Fi stereo VCR and output jacks for extra sound recording equipment .
 - Connect the PLAY jacks to the AUDIO PLAY or OUTPUT jacks of the VCR.
 - Connect the REC jacks to the AUDIO REC or INPUT jacks of the VCR.

Note : The audio and video inputs and outputs of the VCR must be connected to allow the VCR 2/CAMCORDER inputs on the front of the receiver to be used for recording input.

- **TAPE MON PLAY/REC** – PLAY(input) and REC(output) jacks for connecting a cassette deck, a Digital Compact Cassette deck or another digital recording device.
 - Connect the PLAY jacks to the PLAY or LINE OUTPUT jacks of the deck.
 - Connect the REC jacks to the REC or LINE INPUT jacks of the deck.

These PLAY and REC jacks may also be connected to the LINE OUTPUT and INPUT jacks of an audio processor such as an optional graphic equalizer or a Digital Signal Processor.

4. VIDEO IN/OUT

- **VCR 1 IN/OUT** – PLAY(input) and REC(output) jacks for connecting the video output and input of a VCR.
- **MONITOR OUT** – output jack for connecting to the video input of a TV set. The TV set must then be switched to that input.

5. SUBWOOFER

- output jacks for driving subwoofer.
- Connect this jack to SUBWOOFER input jack of a separate amplifier or a powered SUBWOOFER.

6. DIGI LINK III SYSTEM CONTROL

(colored green) – remote control jacks for connection to the corresponding DIGI LINK II or III jacks of a Sherwood CD (Compact Disc) or tape player. Connect this jack to the DIGI LINK III jack of the external Sherwood equipment that uses the DIGI LINK II or III remote control system.

These jacks have been added to maintain compatibility with other Sherwood products.

7. REAR SPEAKERS

Terminals for connecting a pair of rear speakers, impedance of 4 Ω each, to obtain a surround sound effect.

Note : Always connect **two** speakers to these terminals.

8. CENTER SPEAKER

Terminals for connecting a center speaker, impedance of 8 Ω

9. FRONT SPEAKERS

Terminals for connecting a pair of main speakers, impedance of 8 Ω (L = left, R = right).

- One of the wires of a speaker cable is marked with a color or rib. Connect the marked wire to the red terminal, the non-marked wire to the black one.

POWER

10. AC POWER CORD

Connecting the receiver to the wall socket.

11. OUTLET

- Switched output for connecting AC power plugs from various units such as cassette deck, CD player, etc. (Maximum total capacity is 1 A or 100 W)

- Power off mode : Switched AC outlet off
- Power on mode : Switched AC outlet on

CONNECTING HEADPHONES

- Connect a headphone with a 1/4" plug to the PHONES jacks.
- Inserting the plug will not disconnect the speakers.
- Only in surround off mode, you can enjoy private listening with a headphone.

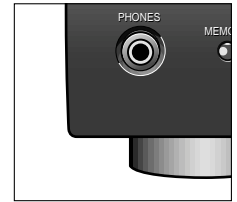

SPEAKER POSITIONING

To obtain the best surround sound effect in your home, place the speakers as shown below.

The left and right speakers should be about 1 m (40") from the TV set.

The center speaker should be above or below the TV set. The rear speakers should be placed 2~3 feet above the ear level of a seated listener on the direct left and right of them. Refer to the fold-out for additional information.

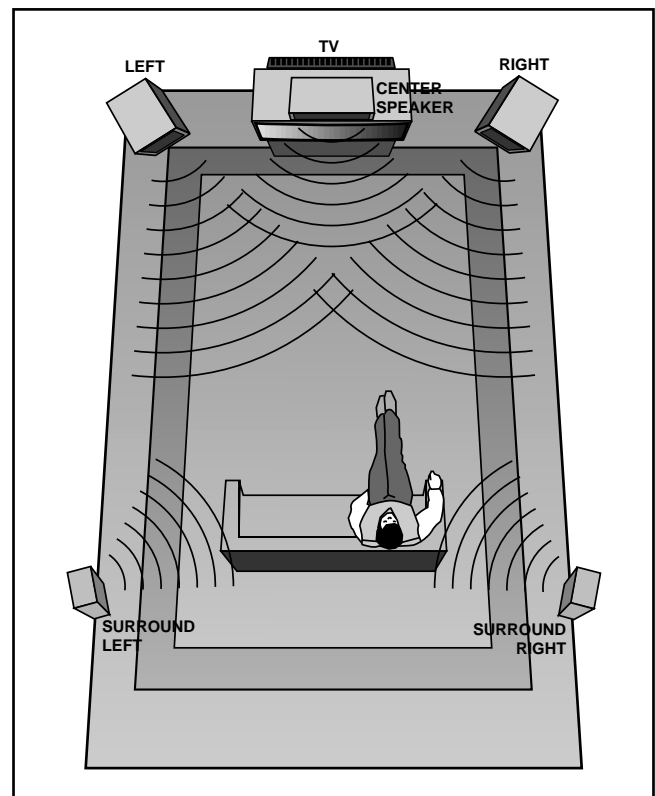

Note : to avoid interference with the TV picture, use only magnetically shielded front speaker systems.

After making all necessary connections (some may not apply to your system set-up), your system is ready for use. In the next chapter, we will describe how to operate your RV-4060R receiver.

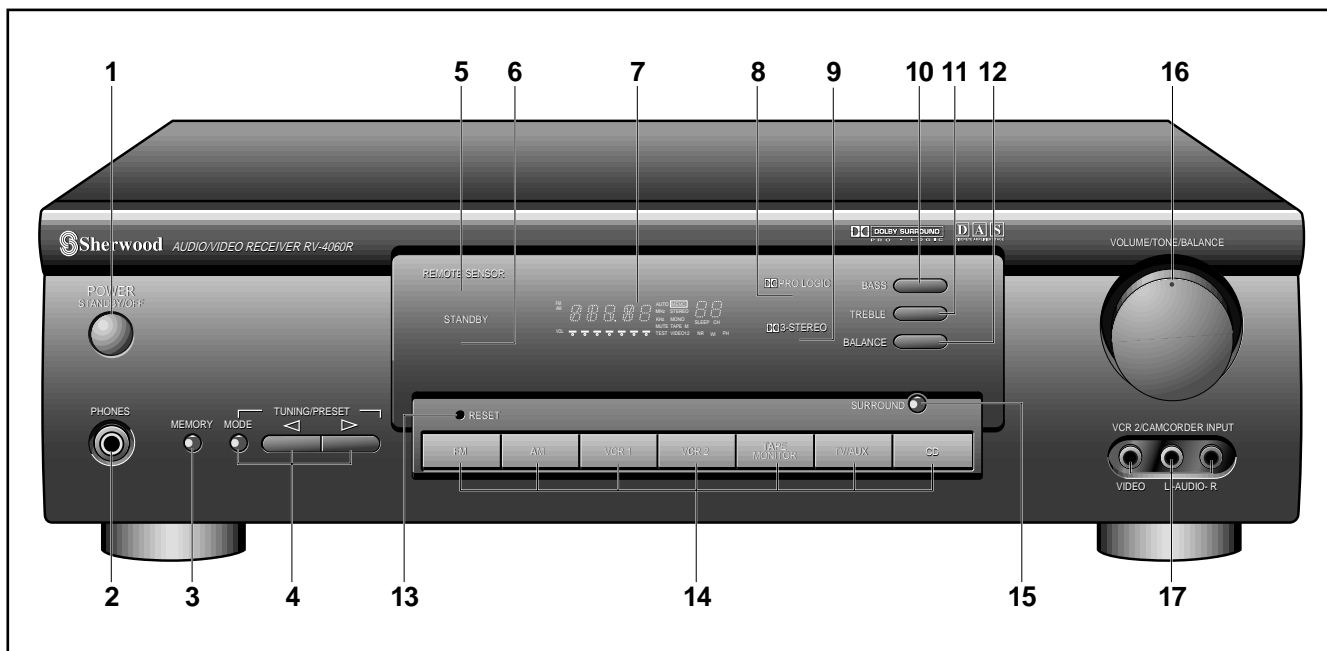

FRONT PANEL

1. POWER SWITCH

For switching the unit on and off.

2. PHONES

For connecting headphones.

3. MEMORY BUTTON

For storing preset stations.

4. TUNING/PRESET BUTTONS

MODE : – For selecting the frequency or preset mode.
 ◀/▶ : – For adjusting the station frequency or selecting the next/previous tuner preset.
 (use together with the MODE button)

5. REMOTE SENSOR

Infrared remote control sensor for receiving signals from the remote control.

6. STANDBY INDICATOR

When in the standby mode, this indicator lights up.

7. FLUORESCENT DISPLAY

Informs you about the function of the receiver.

8. DOLBY PRO LOGIC INDICATOR

When in the DOLBY PRO LOGIC mode, this indicator lights up.

9. DOLBY 3 STEREO INDICATOR

When in the DOLBY 3 STEREO mode, this indicator lights up.

10. BASS BUTTON

For selecting the bass tone mode.

11. TREBLE BUTTON

For selecting the high tone mode.

12. BALANCE BUTTON

For selecting the balance mode.

13. RESET BUTTON

For resetting the unit in case of malfunction.
 • Press RESET for more than 5 seconds after switching off.

14. INPUT SELECTOR BUTTONS

For selecting the required audio or video source.

15. SURROUND MODE BUTTON

For selecting the surround mode:
 ◻◻ PRO LOGIC, ◻◻ 3 STEREO OFF,

16. MASTER VOLUME/TONE/BALANCE CONTROL

For adjusting the volume, bass tones, high tones or balance of the volume between the left and right channel.

17. VCR 2/CAMCORDER AUDIO/VIDEO INPUT

Connections for an extra VCR, camcorder video game player or DSS system. The audio jacks may also be used for an extra audio source like a CD player or cassette deck.

FUNCTION OVERVIEW

DISPLAY

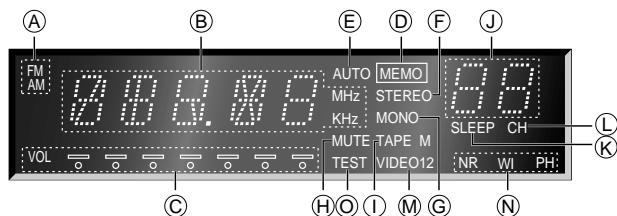

- A AM/FM INDICATOR**
Lights up according to the selected band.
- B FREQUENCY/CHARACTER DISPLAY**
Shows the selected station frequency or the corresponding words when selecting a input source, adjusting tone(bass and treble) level and balance or operating test tone.
- C VOLUME/TONE/BALANCE LEVEL INDICATORS**
Show the settings of the volume, tone(bass and treble) and balance.
The red (·) indicator means the center level of the balance control.
- D MEMORY INDICATOR**
Lights up when the MEMORY button is pressed.
- E AUTO INDICATOR**
Lights up when operating the auto tuning.
- F STEREO INDICATOR**
Lights up when in FM stereo mode.
- G MONO INDICATOR**
Lights up when in FM mono mode.
- H MUTE INDICATOR**
Lights up when the MUTE button on the remote control is pressed.
- I TAPE MONITOR INDICATOR**
Lights up when the TAPE MONITOR button is pressed.
- J CHANNEL NUMBER/SLEEP TIME/LEVEL DISPLAY**
Shows the selected channel number, sleep time in minutes, bass or treble level from -6 to 6.
- K SLEEP INDICATOR**
Lights up when in sleep timer ON mode.
- L CHANNEL INDICATOR**
Lights up when the preset station is received.
- M VIDEO 1/VIDEO 2 INDICATOR**
When VCR1 or VCR2 is selected, the corresponding indicator lights up.
- N NR(normal)/WI(wide)/PH(phantom) INDICATOR**
During the DOLBY PRO LOGIC or DOLBY 3 STEREO operation, the corresponding center mode indicator lights up.
- O TEST TONE INDICATOR**
Lights up when operating test tone.

REMOTE CONTROL

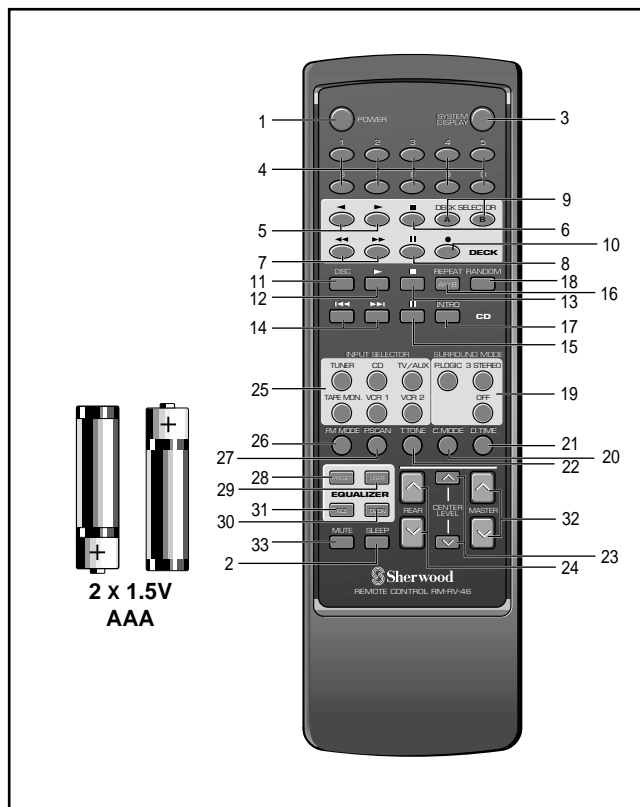

The remote control (supplied) can be used to operate functions of the receiver. In addition, it can be used to operate any other Sherwood equipment that uses the DIGI LINK II or III remote control system.

BATTERIES

- Open the battery compartment and insert two batteries as indicated, size AAA cells.
 - Remove the batteries when they have run down or if the remote control will not be used again for a long period.
- Note :** Do not use rechargeable batteries.

USING THE REMOTE CONTROL

- First press the power switch on the front panel of RV-4060R.
- Select the source you wish to control by pressing one of the six input selector buttons on the remote control (e.g.TAPE MON, CD, etc.).
- Then, select the desired function.







AMPLIFIER

1. **POWER** – for power control of this receiver or system. (as described in amplifier chapter titled "POWER STANDBY/ON).
2. **SLEEP** – for setting a time period after which the system will automatically be switched to standby.
3. **SYSTEM DISPLAY** – for dimming displays of Sherwood components connected by DIGI LINK II or III.

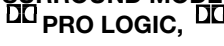
25. INPUT SELECTORS

33. **MUTE** – for muting the sound.





SURROUND CONTROLS

19. **SURROUND MODE**
 **PRO LOGIC, 3 STEREO, OFF** – for selecting the different surround modes.
20. **CENTER MODE** – for selecting the desired center mode when in Dolby Pro Logic or Dolby 3 Stereo mode.
21. **DELAY TIME** – for adjusting the delay time of the rear channel.
22. **TEST TONE** – for checking the output level of the front, center and rear speakers.
23. **CENTER LEVEL**  /  – for adjusting the center level (only in normal mode or wide mode).
24. **REAR LEVEL**  /  – for adjusting the rear level (in Dolby Pro Logic mode)
32. **MASTER VOLUME**  /  – for adjusting the volume.

TUNER





4. **0-9 DIGITS** – for selecting the preset stations.
26. **FM MODE** – for selecting the stereo or mono mode when listening to FM.
27. **PRESET SCAN** – for scanning the stations memorized .

CASSETTE DECK

5.  – for starting reverse or forward side play.
6.  – for stopping recording/play.
7.  – for winding the tape.
8.  – for pausing recording/play.
9. **DECK SELECTOR A, B** – for selecting deck A or B.
10.  – for recording.

In the DIGI LINK III remote control system, if pressing PLAY, etc. on CD or Deck, CD or TAPE MONITOR is selected automatically without selecting the input and PLAY, etc. starts.

COMPACT DISC PLAYER

4. **0-9 DIGITS** – for track selection, press required button among 10 buttons on the remote control and for disc selection, select disc No. (1~5) within 2 sec. after pressing the DISC button.
11. **DISC** (CD changer only) – for disc selection.
12.  – to begin play.
13.  – to stop play/clearing a program.
14.  – for skipping backward and forward.
15.  – for pausing play.
16. **REPEAT A<>B** – for repeating a specific passage.
17. **INTRO** – to preview each track only for 10 seconds.
18. **RANDOM** – to play tracks randomly.

EQUALIZER

28. **PRESET** – for selecting equalizer pattern.
29. **USER** – for adjusting equalizer pattern as desired.
30. **TAPE MON** – for monitoring the sound of recording or playback of cassette deck.
31. **FILE** – for selecting desired equalizer pattern in the preset or user mode.

POWER ON/OFF

- Press the POWER switch to turn the power on.
- The receiver enters the operating mode and the respective indicators lights up.
- To turn the power off, press the POWER switch again.
- The power is cut off and the respective indicators lights off.

POWER STANDBY/ON

- In the operating mode, press the POWER button on the remote control.
- The receiver enters the standby mode, the respective indicators light off and the standby indicator lights up.
In the standby mode, the receiver is not disconnected from the AC mains and a small amount of current is retained to support the memorized contents and operation readiness.
- If the electricity fails or the AC cord is leaved unplugged for more than 2 weeks(power off mode), the memorized contents are all cleared.
- In the standby mode, press the POWER button on the remote control.
- The power is turned on, the respective indicators light up and the standby indicator lights off.

SOUND CONTROL

Volume

- Adjust the overall volume with MASTER VOLUME.

Balance

- Press BALANCE.
- *BAL* lights up.
- Adjust the stereo balance between the left and the right channel with the VOLUME/TONE/BALANCE control.

Treble

- Press TREBLE.
- *TRE* lights up, together with the setting level.
- Adjust the high tones from MIN to MAX with the VOLUME/TONE/BALANCE control.

Bass

- Press BASS.
- *BASS* lights up, together with the setting level.
- Adjust the bass tones from MIN to MAX with the VOLUME/TONE/BALANCE control.

WARNING : Extreme settings at high volume may damage your speakers!.

- Use SURROUND MODE to select the desired sound effect: **PRO LOGIC**, **3 STEREO**
- Press **MUTE** on the remote control if you want to silence the speakers temporarily.
- Press again to restore the same listening level as before.

INPUT SELECTION

- Select the desired input on the receiver or the remote control.
- The selected input will appear on the display.
- When the TAPE MONITOR button is set to on so that "TAPE M" indicator lights up, other inputs can not be heard from the speakers.
To listen to a input other than TAPE MONITOR, be sure to set the TAPE MONITOR button to off.

TAPE MONITOR function

You can connect either a cassette deck or a graphic equalizer to the receiver's TAPE MONITOR jacks. Only when you listen to the component to these jacks, set the TAPE MONITOR button to on.

If you connect a 3-head cassette deck, you can listen to the sound being recorded during recording, not the source sound.

For further details, refer to the operating instructions of the component connected.

SURROUND MODE

With SURROUND MODE, you can select 2 different surround modes: **PRO LOGIC**, **3 STEREO, OFF**.

DOLBY PRO LOGIC : choose this setting to play back movies and music (especially Laser Discs, video cassettes and TV broadcasts with DOLBY SURROUND sound). Not only does Dolby Pro Logic surround provide you with sound, it also gives you a clear perception of the position and direction of the sound. Make sure your 'Speaker Positioning' is correct. (see 'INSTALLATION')

With a great number of recently made movies, the sound track is specially encoded with the Dolby Surround mode carrying the **DOLBY STEREO** or **DOLBY SURROUND** trademark. The front speakers provide the dialogue and the normal stereo effect, while the rear speakers reproduce the surround signals. This position provides excellent results when watching television programs, video software, video discs or video tapes of stereo television broadcasts encoded with Dolby Surround.

Note : In DOLBY PRO LOGIC mode, the rear speakers are used as "EFFECT SPEAKERS" and may not produce sound at all times.

DOLBY 3 STEREO : Choose this setting to play back movies and music (especially Laser Discs, video cassettes and TV broadcasts with DOLBY SURROUND sound) when not using the rear speakers. You get a clear perception of the position and direction of the sound.

DOLBY 3 STEREO combines the front and rear signals so that you can enjoy a regenerated sound field, which has comparatively more lively presence and a more expansive feeling from the three front channels (front left, front right and center speakers) than that of ordinary stereo regeneration.

OFF : Turns off the center and rear speakers for normal stereo operation.

Note : Dolby Pro Logic and Dolby 3 Stereo will not work properly if the signal passes through a graphic equalizer. Please refer to your equalizer operating instructions for guidance on switching off (or defeating) the equalizer.

SURROUND MODE CONTROL

Each surround mode has programmed values for center-mode, center and rear levels and/or for rear channel time delay (as appropriate).

These values will then be kept in the memory until they are changed again.

The various values that can be adapted in the different surround modes are described next:

DOLBY PRO LOGIC

- Use the SURROUND MODE or press **PRO LOGIC** button on the remote control.
- Press the CENTER MODE button to select the required center channel mode :

NORMAL – If the center speaker is a smaller model, which means it will not reproduce bass as deep or as loud as the left and right speakers.

WIDE – If all three front speakers are identical and capable of reproducing low bass information and if equal power is available in the left, center and right amplifiers.

PHANTOM – If no center speaker is installed.

- Use the REAR LEVEL buttons to adjust the rear level (related to the front level).
 - SUR lights up on the display.
 - The level will be indicated on the display : $\text{vol. } \overset{\text{SUR}}{\text{---}} \dots$
- Use the DELAY TIME button to adjust the delay time of the rear channel.
 - The delay time of the rear channel is changed to 15, 20, 25, 30 milli seconds.
- Use the CENTER LEVEL buttons to adjust the center level.
 - CEN lights up on the display.
 - The level will be indicated on the display : $\text{vol. } \overset{\text{SUR}}{\text{---}} \dots$

DOLBY 3 STEREO

- Use the SURROUND MODE or press the **3 STEREO** button on the remote control.
 - CENTER MODE : In Dolby 3 Stereo mode, you can only select **NORMAL** and **WIDE**.
 - CENTER LEVEL : Use the CENTER LEVEL buttons to adjust the center level as described above.
 - REAR LEVEL : Adjusting the rear level is not available in Dolby 3 Stereo mode.
 - DELAY TIME : Adjusting the delay time of the rear

channel is not available in Dolby 3 stereo mode

TEST TONE

Use TEST TONE button on the remote control to obtain the correct balance between the levels of the left, right, center and rear speakers in the DOLBY PRO LOGIC and DOLBY 3 STEREO mode.

DOLBY PRO LOGIC

- Press the TEST TONE button on your remote control.
- You will hear a test tone from the left (*FL*), center (*C*), right (*FR*) and rear (*R*) speakers in turn, in repeating a cycle.
- While sitting in the usual listening position, adjust the level of the center and the surround channels to get the same sound level with the front channel.
 - The levels will be indicated on the display.
- When you are satisfied with the levels, press the TEST TONE button on your remote control again to turn off the test tone.

DOLBY 3 STEREO

In the Dolby 3 Stereo mode you can adjust only the levels of the left, right and center speakers.

- Manufactured under license from Dolby Laboratories Licensing Corporation. "Dolby", **PRO LOGIC** and "PRO LOGIC" are trademarks of Dolby Laboratories Licensing Corporation.

GENERAL

- Select the waveband by pressing the FM or the AM button
- Tune to a radio station or select a preset number.
The correct procedure is described in the following chapters.
- While tuning, the audio signal will be muted to eliminate interfering background noises.
Once a station is found, the audio signal will be set to normal volume again.
- When STEREO appears on the display, you are receiving an FM stereo transmission.
- A disturbing noise, due to a weak FM stereo signal, can be suppressed by pressing FM MODE on the remote control.
- STEREO will disappear on the display and you will hear the FM program in mono.

TUNING

AUTOMATIC TUNING

- Press MODE to switch off CH Indicator.
- Press TUNING/PRESET ◀ or ▶ for more than 1 second.
- AUTO appears on the display. The tuner will now search until a station of sufficient strength has been found. The display shows the tuned frequency.
- If the station found is not the desired one, simply repeat this operation.
- Weak stations are skipped during automatic tuning.
They can be tuned to manually.

MANUAL TUNING

Manual tuning is useful when you already know the frequency of the desired transmitter (e.g. from your program guide).

- Press MODE to switch off the PRESET mode.
- Briefly press TUNING/PRESET ◀ or ▶ until the right frequency has been reached
- Tuning intervals:

BAND	USA/CANADA	EUROPE/AUSTRALIA
FM	200 kHz	50 kHz
AM	10 kHz	9 kHz

PRESET STATIONS

You can store 30 preferred stations in the memory of the tuner. This enables you to find your favorite stations quickly and easily.

PROGRAMMING OF PRESET STATIONS

- Tune either automatically or manually to the frequency to be stored (as described under TUNING).
- If the display shows no preset number, the frequency shown has not yet been stored in the memory.
- Press MEMORY to enter the frequency in memory.
- MEMO starts flashing for about 5 seconds.
- Select the preset number using TUNING/PRESET ◀ or ▶ within the time the MEMO indication flashes.
- Press MEMORY again.
- The preset station has now been stored in the memory.
A stored frequency is erased from the memory by storing another frequency in its place.

TUNING TO PRESET STATIONS

- Press MODE to switch on the CH indicator.
- Select the desired preset number with TUNING/PRESET ◀ or ▶.
- The selected station will be tuned in and the display will show the preset number and the tuned frequency.

With the digit buttons on the remote control

- Enter the preset number you have already stored in the memory with the digit buttons on the remote control.
- The tuner selects the frequency of the preset number and the station becomes audible.
- The tuner will return to the previous frequency if other buttons are pressed.

SLEEP

The sleep mode allows the system to continue to operate for a specified period of time before automatically shutting off.

- Press the SLEEP button on the remote control to set the receiver to automatically turn off after 10, 20, 30, 60 or 90 minutes.
- Each time the button is pressed, the setting is changed as below;

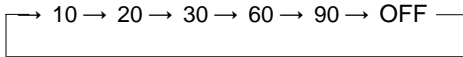

- Select the required sleep time by pressing SLEEP : 10, 20, 30, 60 or 90 minutes.

Notes:

- During an active sleep timer period, you can reset the SLEEP time again by pressing the SLEEP button.
- A sleep timer period will be cancelled when you switch your system to standby (using the POWER button on your remote control).

RECORDING WITH A CASSETTE DECK

- Select the desired input to be recorded.
- Start recording on the TAPE MONITOR.
- Start play on the desired input.
- For tape monitor function, refer to amplifier chapter titled "TAPE MONITOR function".

DUBBING FROM VCR2 TO VCR1

- Select VCR2 as program source to be recorded.
- Start recording on the VCR1.
- Start playback on the VCR2.
- The audio and video signals from VCR2 will be dubbed onto the tape in VCR1.

When dubbing from VCR2 to VCR1, you can replace the audio signal from VCR2 with the signal from an audio source, e.g. a CD player.

- First select VCR2 as program source to be recorded.
- Then select the required audio source.
- Start recording on the VCR1.
- Start playing back on the audio alternate source and on the VCR2.
- You can now watch the picture from VCR2 on your TV and listen to the sound from the audio source while recording.

TECHNICAL SPECIFICATIONS

AMPLIFIER SECTION

- Output power : Continuous Average (left/right), 8 Ω THD 0.7%, 40 Hz~20 kHz2 × 50 W
- Surround mode :
 - front2 × 35 W
 - rear35 W
 - center35 W
- Total harmonic distortion, 1 kHz ≤ 0.3%
- Intermodulation distortion ≤ 0.5%
- Frequency response, 1 W, -3 dB
 - linear30 Hz~40 kHz
- Signal - to - Noise Ratio, IHF "A" weighted ≥ 90 dB
- Stereo Separation, 1 kHz ≥ 55 dB
- Damping factor, 8 Ω ≥ 40
- Bass/Treble control, 100 Hz/10 kHz +/-10 dB
- Input Sensitivity
 - Linear inputs180 mV (rated output)
- Outputs
 - Recording, 2.5 kΩ200 mV
 - Headphones8-1,000 Ω
 - speakersFront L/R, Center : 8Ω
Rear : 4Ω

FM TUNER SECTION

- Tuning frequency range87.5~107.9 MHz
- Usable sensitivity17.2 dBf
- 50 dB quieting selectivity, mono/stereo21.2/41.2 dBf
- Signal to noise ratio, 65 dBf, mono/stereo-68/65 dB
- Total harmonic distortion, 65 dBf, 1 kHz, mono/stereo0.3/0.5 %
- Frequency response, 30~15,000 kHz +/-1 dB
- Stereo separation, 1 kHz32 dB
- Capture ratio1.25 dB
- IF rejection ratio75 dB

AM TUNER SECTION

- Tuning frequency range520~1710 kHz
- Usable sensitivity800 μV/m
- Signal to noise ratio40 dB
- Selectivity25 dB

POWER SUPPLY

- Mains voltage120 V/60 Hz
- Power consumption140 W
- Main outlet1 A or 100 W max.

CABINET

- Dimensions (w × h × d)440 × 110 × 280 mm approx
(17-5/16 × 4-11/16 × 11 inches)
- Weight7.5 kg approx
(16.5 lbs)

ACCESSORIES

- Remote control unit1x
- AM Loop Antenna1x
- FM T Antenna1x

Note : Design and specifications subject to change without notice for improvements.

MAINTENANCE

- Do not leave the unit in direct sunlight or other places where high temperatures can occur for any length of time, such as in the vicinity of a heating source.
- Do not expose the equipment to humidity or rain.
- A chamois leather cloth, slightly moistened with water is sufficient for cleaning the cabinet.
- Do not use cleaning agents containing alcohol, spirits, ammonia or abrasives.

If a fault occurs, run through the points listed below before taking your receiver for repair.

If the fault persists, attempt to solve it by *switching the receiver off and on again*. If this fails to resolve the situation, consult your dealer. *Under no circumstances should you repair the receiver yourself as this will invalidate the guarantee!*

PROBLEM

- *POSSIBLE CAUSE*
- REMEDY

NO POWER

- *The AC power cord is disconnected.*
- Connect the cord securely.
- *Poor connection at the wall socket or the wall socket is inactive.*
- Check the wall socket using a lamp or another appliance.

NO SOUND FROM THE FRONT SPEAKERS

- *Speaker cables are disconnected.*
- Check the speaker connections.
- *Volume is too low.*
- Adjust the volume.

NO SOUND FROM THE REAR SPEAKERS

- *Surround mode is switched off.*
- Select a surround mode.
- *Volume and rear level are too low.*
- Adjust the volume.
- *A monaural source is used.*
- Select a stereo or surround source.
- *Dolby 3 Stereo mode is selected.*
- Switch off Dolby 3 Stereo mode.
- *Dolby Pro Logic source is not present.*
- Make sure that your video device is in the stereo mode.

NO SOUND FROM THE CENTER SPEAKER

- *Dolby Pro Logic or Dolby 3 Stereo mode is not selected.*
- Select Dolby Pro Logic or Dolby 3 Stereo mode.
- *Volume and center level are too low.*
- Adjust the volume and center level.
- *The center mode is set to phantom mode.*
- Set the center mode to normal or wide.

NO SOUND IS HEARD, EVEN WHEN INPUT SELECTION IS MADE

- *The MUTE button is pressed.*
- Press MUTE again to cancel the MUTE function.
- *Volume is too low.*
- Adjust the volume.
- *Connections between the components are incorrect.*
- Make connections correctly.

THE REMOTE CONTROL UNIT DOES NOT OPERATE

- *No batteries loaded or dead batteries.*
- Replace the batteries.
- *The remote sensor is obstructed.*
- Remove the obstacle.

– *No antenna connected.*

- Connect an antenna.
- *The desired station frequency is not tuned in.*
- Tune in the desired station frequency.
- *Antenna in wrong position.*
- Move antenna and retry turning.
- *Surrounding area causing interference.*
- Lengthen or elevate antenna.

PRESET STATIONS CANNOT BE RECEIVED

- *An incorrect station frequency has been memorized.*
- Memorize the correct station frequency.
- *The memorized stations are cleared.*
- Memorize the stations again.

POOR FM RECEPTION

- *No antenna connected.*
- Connect an antenna.
- *The antenna is not positioned for the best reception.*
- Change the position of the antenna.

CONTINUOUS HISSING NOISE DURING FM RECEPTION, ESPECIALLY WHEN A STEREO BROADCAST IS RECEIVED

- *Weak signal.*
- Change the position of the antenna.
- Install an outdoor antenna. Use an antenna with 3, 4 or 5 elements if the broadcast station is far away.

CONTINUOUS OR INTERMITTENT HISSING NOISE DURING AM RECEPTION, ESPECIALLY AT NIGHT

- *Noise is caused by motors, fluorescent lamps or lightning, etc.*
- Keep the receiver away from noise sources.
- Install an outdoor AM antenna.

A HUM CAN BE HEARD DURING AM RECEPTION

- *The AC power cord may be too close to the AM loop antenna or the antenna wire.*
- Position the AC power cord away from the antenna wire and the AM loop antenna.
- Adjust the position of the AM loop antenna.

OTHER SYSTEM COMPONENTS DO NOT REACT TO REMOTE CONTROL COMMANDS

- *DIGI LINK III connections are not made properly.*
- Make proper DIGI LINK III connections.

STATIONS CANNOT BE RECEIVED

O P E R A T I N G I N S T R U C T I O N S



RV-4060R
AUDIO/VIDEO
RECEIVER