

Clarion®

VMA6492

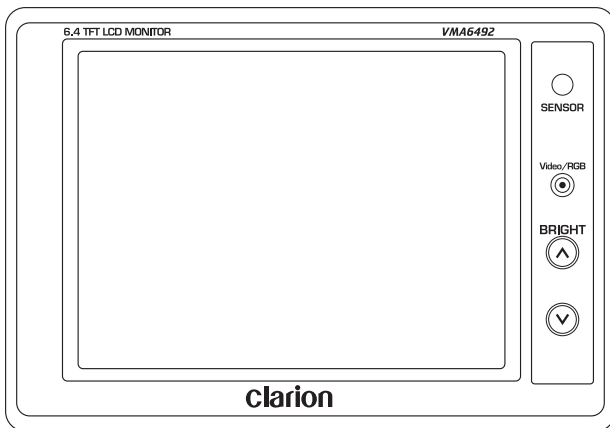

6.4" ACTIVE MATRIX TFT
COLOR LCD MONITOR

OWNER'S MANUAL
INSTALLATION GUIDE

WARNING!

THE CLARION VMA6492 LCD MONITOR IS DESIGNED FOR REAR SEAT PASSENGER VIEWING ONLY.

THIS PRODUCT IS NOT INTENDED FOR VIEWING BY THE DRIVER WHILE THE VEHICLE IS IN MOTION SINCE SUCH USE MAY DISTRACT THE DRIVER OR INTERFERE WITH THE DRIVER'S SAFE OPERATION OF THE VEHICLE AND MAY RESULT IN SERIOUS INJURY OR DEATH. SUCH USE MAY ALSO VIOLATE STATE LAW.

CLARION DISCLAIMS ANY LIABILITY FOR ANY BODILY INJURY, INCLUDING FATALITIES, OR PROPERTY DAMAGE THAT MAY RESULT FROM ANY IMPROPER OR UNINTENDED USES OF THIS PRODUCT.

INTRODUCTION:

The VMA6492 is a TFT active matrix color LCD monitor which delivers a striking picture with superior image resolution. The VMA6492 integrates into a Clarion mobile multimedia systems using a VDH9600 (*mobile VCR Recorder*) even if no TTX001 (*mobile TV tuner*) is connected. The Clarion VMA6492 is a full-featured 6.4" LCD Color Monitor and has the following:

- 6.4" wide-screen color LCD panel
- A bright vibrant clear screen
- RCA composite video & RGB 8-pin DIN Style inputs
- Side mount threaded holes for easy installation with all Clarion brackets

ABOUT THIS MANUAL AND WARRANTY:

To start enjoying your new Clarion VMA6492 monitor, please read the instructions listed in this manual. Keep all instructions for future reference. Please fill out and send in the enclosed warranty card to protect your purchase and aid in warranty service. Also, **save your original sales receipt as proof of purchase.**

TABLE OF CONTENTS:

INTRODUCTION, ABOUT THIS MANUAL & TABLE OF CONTENTS	1
PRECAUTIONS & DESCRIPTION OF BUTTONS AND CONNECTORS	2
DESCRIPTION OF PICTURE ADJUSTMENT	3
CARE AND MAINTENANCE	3
WIRING PRECAUTIONS	3
DESCRIPTION OF INSTALLATION	3
APPLICATIONS (with VDH9600, TTX001, and FM100S)	5
STAND ALONE SYSTEM (with TTX001 and WH100/WH200)	6
DESCRIPTION OF RC300 REMOTE BUTTONS:	8
TROUBLESHOOTING	9
SPECIFICATIONS	9

INTRODUCTION

PRECAUTIONS:

- This monitor is intended for use in DC 12V, negative ground vehicles.
- Do not operate the monitor in ways other than described in this guide. Doing so may cause damage and void the warranty.
- Be careful not to run down the car's battery while using a multimedia system with the engine stopped. Doing so may damage the vehicle's battery or the multimedia system.
- Do not disassemble or modify the monitor. Doing so may damage it and void the warranty.
- Keep moisture away from the set. Water and humidity may damage the internal circuitry.
- Do not let the monitor become overheated. If the temperature inside the vehicle is high or the monitor has been exposed to direct sunlight, lower the monitor's temperature before use. (The liquid crystal panel operates within a temperature range of 30 – 113 degrees F).
- In extremely cold temperatures, the movement of the picture may slow and the picture may become dark. The monitor will work normally once the temperature increases to its normal operation range.
- Small black or shiny dots may be seen inside the liquid crystal panel. These are normal when manufacturing liquid crystal products.

DESCRIPTION OF BUTTON AND CONNECTORS:

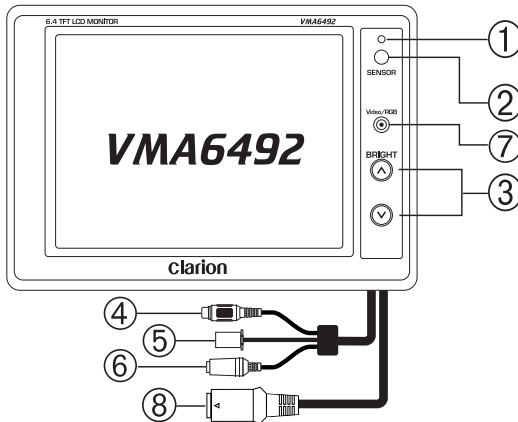

- | | |
|-----------------------|-------------------------------------|
| ① Power Indicator LED | ⑤ 2-Pin Molex Power Connector |
| ② Remote Sensor | ⑥ IR Serial Remote OUT |
| ③ Brightness Controls | ⑦ Input Selector Switch - Video/RGB |
| ④ Video IN RCA | ⑧ 8-pin RGB input DIN cable |

DESCRIPTION OF PICTURE ADJUSTMENT:**BRIGHTNESS:**

To adjust the picture brightness, use the Brightness UP and DOWN buttons ③ located on the front panel of the VMA6492. Press and hold the UP button to increase the picture brightness. Press and hold the DOWN button to decrease the picture brightness (*see page 2 for button locations*).

VIEWING ANGLE:

To adjust the viewing angle gently tilt the cabinet to the desired position. The recommended viewing angle of the unit is – 30 to +10 degrees vertical and +45 to –45 degrees horizontal.

CARE AND MAINTENANCE:*Cleaning the Cabinet:*

- Use a soft, dry cloth to gently wipe off any dirt.
- Do not use benzene, thinner, car cleaner, etc., as these substances may damage the cabinet or cause the paint to peel.

Cleaning the LCD Panel:

- Use a soft, dry cloth to gently wipe off any dust.
- The surface is easily scratched; do not rub it with hard objects.

WIRING PRECAUTIONS:

Read all wiring precautions. If you are not sure of the connections, contact your authorized Clarion dealer.

NOTE: The VMA6492 monitor displays video images only. It does not provide audio output. Refer to the Applications, starting on page 5, of this owner's manual for proper connection to Clarion's multimedia audio output devices.

1. Disconnect the negative (-) lead from the vehicle's battery before making any connections.
2. When creating passage holes through metal or plastic panels, use grommets to eliminate any sharp edges created during drilling. This will protect power or video wires from nicks or damaged causing a possible short circuit or failure.
3. When connecting the ground lead, fasten the ground lead (black) securely to a clean metal plate on the vehicle. Use sandpaper to remove any paint from the surface where the ground terminal is attached.

DESCRIPTION OF INSTALLATION:**MOUNTING HOLE LOCATIONS:**

Your Clarion VMA6492 monitor, has four (4) additional side threaded mounting holes. Now the VMA6492 is useable with all Clarion's mounting bracket methods (PQE023, ZMT009). The VMA6492 accommodates the ZMT009 gooseneck mount when a bottom mounting screw location is necessary. The VMA6492

Clarion VMA6492 6.4" TFT LCD Monitor

monitor will accept a video signal from any video source with composite video output. The Infrared (IR) sensor will work directly with a Clarion TTX001 or VDH9600 using the IR extension cable provided (*see Application starting on page 5 for details*).

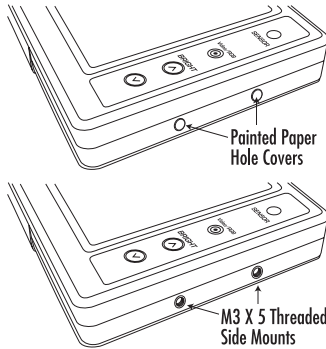

1. Look over the vehicle for a monitor location. Each vehicle is different and locations will vary. Make sure the monitor will not interfere with the driver's safe operation of the vehicle.
2. Once a location has been determined, run the 3.5 mm IR extension, Video RCA and Power molex connector into the monitor's mounting location.
3. Plug each cable into the monitor. Mount the monitor using four (4) M4x8 mm machine screws (*machine screws are provided with the mounting brackets*).
4. Run the IR extension, video, and power cables to their respective destinations. When using the VDH9600 and TTX001 together, make all of your connections near the VDH9600 (*see the figure on page 5 for more details*).

INSTALLATION

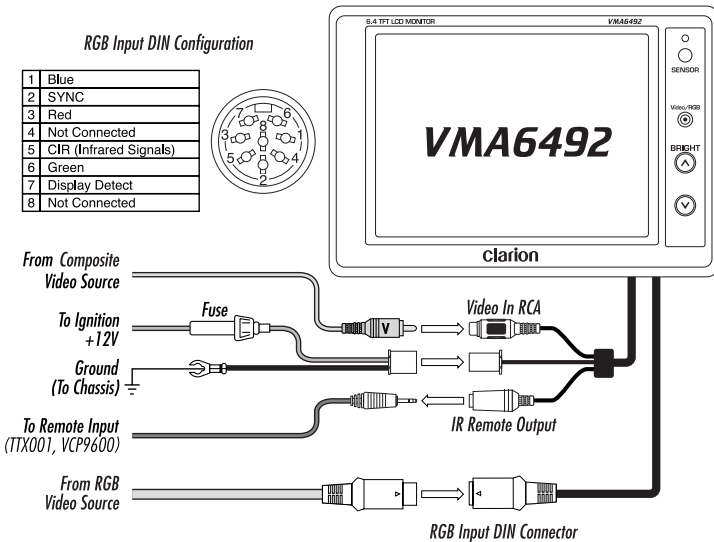

APPLICATIONS: (With the VDH9600, TTX001 and the FM100S)

1. Pick a location to mount the TTX001 TV tuner. Typically the tuner is located close to the VCR player. Avoid areas with excessive heat or moisture.
2. Mount the TV antenna (ZCB-303 or equivalent) and plug it into the TTX001 antenna input connector.
3. Plug the 16-pin A/V Output and 2-pin Power Molex connector into the TTX001 tuner. Using the supplied A/V cable, connect the Left (white), Right (red), and Video (yellow) RCAs into their corresponding LINE IN locations on the back of the VDH9600.
4. Connect the IR extension cable from the TTX001 into one of the jack inputs on the 3.5 mm mono Y-connector (*not provided*). Connect the plug side of the Y-connector to the REMOTE SENSOR INPUT on the back of the video play-

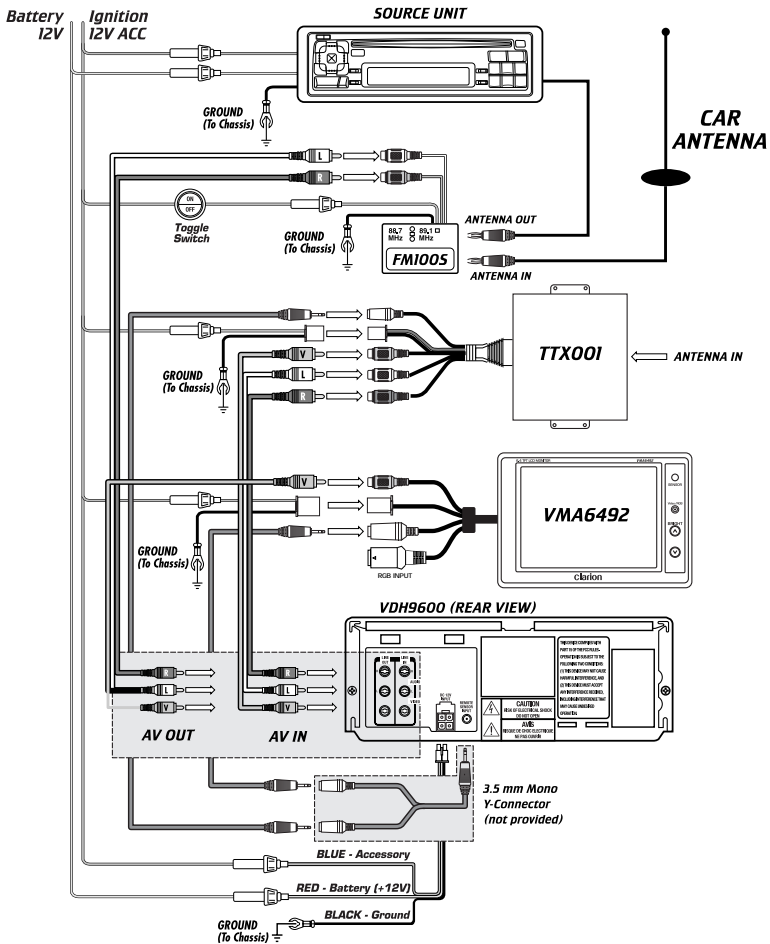

APPLICATIONS

er. Connect the other jack end of the Y-connector into the IR extension cable coming from the VMA6492 monitor.

5. Plug the video RCA from the VMA6492 into the LINE OUT video connection on the rear of the player. Plug the provided audio RCA cable into the L/R LINE OUT audio connections. Connect the power wires from the VMA6492, TTX001, and the power wires of the VDH9600 together.
6. Remove the vehicle's radio. Run both the audio RCAs and power wires to the radio location and plug the audio RCAs into the FM100S audio inputs.
7. Mount the switch for the FM100S and run its' power wire to the radio location. The power wires of the TTX001, video player, VMA6492 and the FM100S can be joined and connected to the radio accessory and battery wires.
8. Plug the vehicle antenna into the antenna input of the FM100S. Plug the antenna output of the FM100S into the radio.
9. The FM100S has a two position switch used to select the modulation frequency (*88.7 or 89.1 Mhz*). Pick the frequency that won't interfere with reception of other radio stations. Set that frequency into the radio's preset memory.

OPERATION: (With the VDH9600, TTX001 and the FM100S)

1. Turn the vehicle ignition switch to the accessory (ACC) position.

NOTE: Since all IR signals are linked together; point any remote control at the SENSOR eye (located on the front of the VMA6492) to activate its' component.

2. Press POWER on the player's remote control to turn the video player ON.
3. Press POWER on the RC-300 remote control to turn the TTX001 TV tuner ON. The TV picture is displayed on the monitor.

NOTE: The VDH9600 automatically loops its A/V inputs through to its A/V outputs, the video signals from the TTX001 passes through to the VMA6492.

4. Toggle the FM100S's switch to the ON position and tune the radio to the modulated frequency. Adjust the vehicle's sound system to a comfortable level.
5. Insert a VHS tape into the VDH9600 player and the VMA6492 monitor will now display the player's video and audio signals.

STAND ALONE SYSTEM: (With TTX001 and WH100/WH200)

1. Pick a location to mount the TTX001 TV tuner. Avoid areas with excessive heat or moisture. Plug the 16-pin A/V Output connector into the TTX001 tuner.
2. Mount the TV antenna (ZCB-303 or equivalent) and plug it into the TTX001 antenna input connector.
3. Once a location has been determined for the VMA6492, run the 3.5 mm IR extension, video RCA and 2-pin Power Molex connector into the monitor's

mounting location. Plug each cable into the monitor. Mount the monitor using four (4) M4x8 mm machine screws (*machine screws are provided with the mounting brackets*).

- Run the IR extension, video RCA, and power wires to the TTX001 location and plug each into the TTX001 tuner (*see the figure below for more details*).
- Pick a location to mount the WH100/200 transmitter, plug in the L/R audio RCAs and power connector. Run the L/R RCAs and power wire to the TTX001's location. Mount the IR Transmitter to its mounting location. At the TTX001, plug the L/R RCAs into the audio outputs.
- Tie all the ground wires to a good ground point. Connect all the power wires together and run to a fused accessory wire in the vehicle.

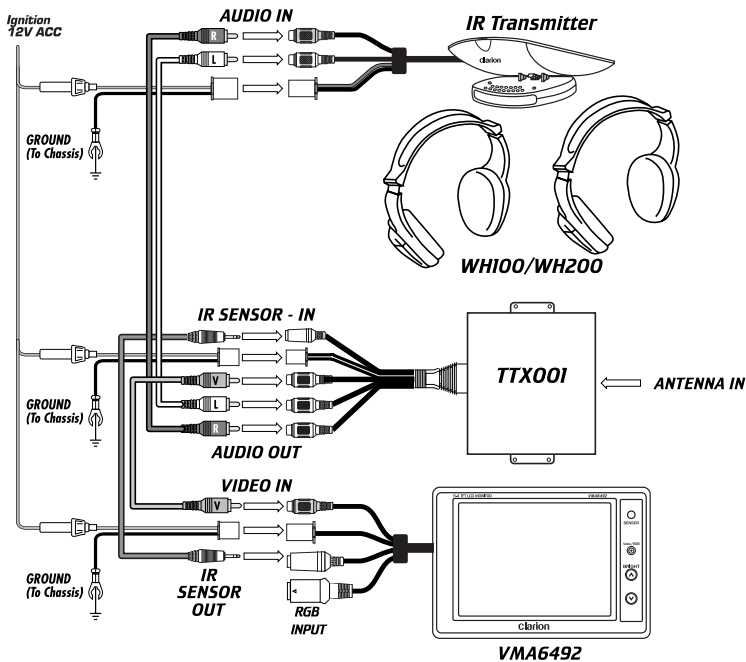

OPERATION: (With TTX001 and WH100/WH200)

- Turn the vehicle ignition switch to the accessory (ACC) position. Since the IR signals from each of the components are linked together, point the RC-300 remote control at the SENSOR located on the front of the VMA6492.
- Press POWER on the RC-300 remote control to turn the TTX001 TV tuner ON. The TV picture is now displayed on the monitor.
- Turn on the IR headphones with its power switch to listen to the audio, adjust the volume level on the headphones to a comfortable level.

DESCRIPTION OF RC300 REMOTE BUTTONS:

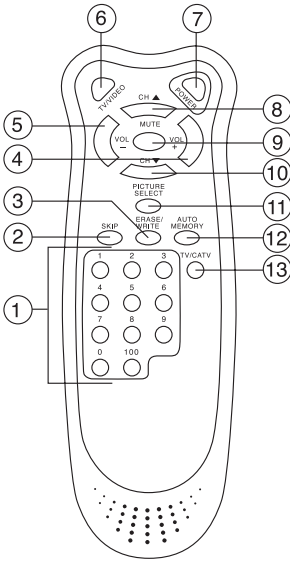

- ① Number Pad
- ② Skip
- ③ Erase/Write
- ④ Volume Up
- ⑤ Volume Down
- ⑥ TV/Video
- ⑦ Power
- ⑧ Channel Up
- ⑨ Mute
- ⑩ Channel Down
- ⑪ Picture Select
- ⑫ Auto Memory
- ⑬ TV/CATV

BATTERY INSTALLATION:

- Insert 2 AAA batteries into the compartment located on the back of the unit, observing the proper polarity.

NOTE: Each time the batteries are changed, the remote channels must be reprogrammed. Use alkaline batteries; do not use rechargeable batteries. Always change all the batteries at the same time.

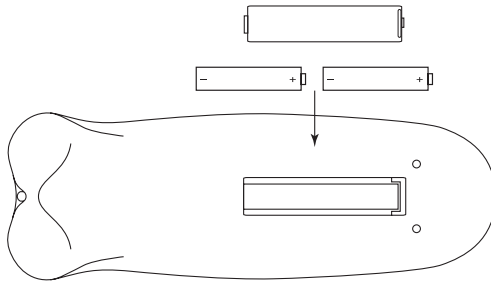

OPERATION:

- To use the remote control, press the Power button to turn on the remote.
- Press the TV/VIDEO button to select the source to be controlled by the remote.
- The VOL(ume) +/- buttons and the MUTE button control the TV volume.

TROUBLESHOOTING:

Symptom	Cause	Solution
System does not work.	Fuse is blown. Power wires are not connected.	Replace external fuse with the same value. Check the wire connections and connect it properly.
The picture has shadows when connected to the TTX001.	The signal condition is poor.	This may due to signals reflected off buildings, mountains, etc. Check again in a different place and direction.
The picture has stripes or spots when connected to the TTX001.	There may be interference signals.	This may due to signal interference from other cars, high voltage lines, neon lights, etc. Check again in another place.
The screen is dark.	The brightness is adjusted too low. Usage conditions are poor.	Check that the brightness is properly adjusted and set it properly. This may happen if the temperature in the vehicle is below 30°F or above 113°F. Check again when the temperature is between 30 and 113°F.
No picture on monitor.	The TV tuner is not set to TV mode (using the TTX001) The TV tuner is set to VTR mode.	Set the TV Tuner function to "TV" mode. In the VTR mode, no picture appears if no video signal is being input to the VIDEO IN terminal of the tuner.

SPECIFICATIONS:

GENERAL SPECIFICATIONS:

Power Requirement:	+12 volts dc (9-16 volts dc)
Power Consumption:	7 watts, Power On 0.58 amps (58 mA)
Weight:	1.1 lb (0.5 kg)
Dimensions (<i>w x h x d</i>):	7-3/8 x 5-1/8 x 1-1/4 in. (188 x 130 x 31 mm)
Supplied Accessories:	3.5mm Male to Male IR extension cable (5 Meters) Video RCA cable (5 Meters) 2-pin Molex Power connector

MONITOR SPECIFICATIONS:

Display Type:	Color TFT Active Matrix LCD
Screen Size:	6.4" (Panel Dimensions 113 x 85mm)
Pixels:	960 x 234
Screen Resolution:	224,640 Dots
Video Input Level (RCA):	1.0 volts peak to peak, NTSC
RGB Input Level:	0.75 volts peak to peak, TTL

FCC STATEMENT

This equipment has been tested and found to comply with the limits for a Class B digital device, pursuant to Part 16 of the FCC Rules. These limits are designed to provide reasonable protection against harmful interference in a residential installation. This equipment generates, uses, and can radiate radio frequency energy and, if not installed and used in accordance with the instructions, may cause harmful interference to radio communications. However, there is no guarantee that interference will not occur in a particular installation.

If this equipment does cause harmful interference to radio or television reception, which can be verified by turning the unit off and on, the user is encouraged to consult the dealer or an experienced radio/television technician for help.

Clarion Corporation of America

661 West Redondo Beach Blvd
Gardena, CA 90247
800-Go-Clarion
www.clarion-usa.com