

Hunter Mfg.
30525 Aurora Rd.
Solon Oh 44139
440-248-6111 FAX 440-248-1691
www.hunterheater.com

Part No. 52707
1/99

HUNTER

Falconaire

Propane Heater
20,000 BTU/HR Model PH20-30A
With Automatic Gas Ignition Control

Installation • Operation • Service



Warning

EXHAUST GASES

Do not operate heater in an enclosed area unless the exhaust gases are piped outside. Exhaust gases may contain carbon monoxide, a colorless and poisonous gas.



Warning

FUEL USE

This heater is designed for use with propane (LP gas) only. Do not attempt to use gasoline as fuel since fire or explosions may result. Use this heater only with gas regulator part number 88301-T supplied with the heater. Operation with other regulators voids all warranties and may result in fire, explosion, or damage to the heater.



Warning

ELECTRICAL

Heater must be grounded through ground screw supplied. Do not use the fuel line as an electrical conductor or ground connections. Use of the fuel line as electrical or ground conductor may result in fire or explosion. Before performing maintenance or inspection (except operating tests), disconnect the power source. Do not operate the heater with the covers off. The tilt switch is a safety device that stops heater operation in case the vehicle overturns.

Do not remove this switch or defeat its purpose.



CAUTION

Do not operate the heater at less than 11volts. Propane flow to the burner head is constant, but blower motor speed and combustion airflow vary directly with voltage. Operation on low voltage will produce poor burning, smoke, and unburned fuel mixtures.

Table of Contents

Section One	3
Introduction and Description	3
Description	3
Section Two	4
INSTALLATION INSTRUCTIONS	4
Pre-Installation Inspection	4
Location and Mounting	4
Electrical Requirements (FIG.1)	6
Fuel Requirements (FIG.2)	6
Exhaust and Combustion Air Requirements (FIG.3)	7
Heater Mounting Dimensions (FIG.6)	8
Fuel Connections	9
Electrical Connections	10
Section Three	12
OPERATION	12
Controls and Indicators	12
Theory of Operation	13
Starting	14
Section Four	15
TROUBLESHOOTING and DIAGNOSTICS	15
Fault Codes	15
Troubleshooting	16
Burner Head Maintenance	16
Preseason Maintenance, Annual Service	17
Section Five	18
PARTS LIST	18
Installation Hardware	18
Case and Heat Exchanger	19
Fuel, Ignition, and Electronic Control System	20
Blower and Motor Assembly	21
Comfort Control and Remote Harness	22
Section Six	23
OPTIONS and ACCESSORIES	23
Remote Calibrated Thermostat Installation	24
External Diagnostic Light Installation	25

Section One

Introduction and Description

This manual contains installation, operation, maintenance, and repair instructions for Model PH-20-30A Heaters manufactured by Hunter Manufacturing Company, Solon, Ohio.

Description

The Falconaire PH20-30A is a 12 VDC Microprocessor Based, Direct Spark Ignition, thermostatically controlled heater. The control utilizes a microprocessor to continually and safely, monitor, analyze and control the proper operation of the gas burner. Value added features such as, combustion blower control, LED diagnostic output, automatic one hour reset, and multiple ignition tries, highlight the controls benefits.

Model PH-20-30A is designed for use solely with propane (LP gas) as fuel. Combustion air is supplied by a single-stage combustion air blower, and fuel flow to the burner head is controlled by a solenoid valve and a restrictor in the fuel line. Because the propane enters the burner head as a gas, no carburetor is required. Ignition of the propane is accomplished with a spark plug-like igniter, which is supplied with high voltage current from the Electronic Control Module (ECM).

SPECIFICATIONS

Heater case dimensions	16 in. long x 11 in. wide x 6 3/4 in. high
Weight	28 lbs.
Shipping weight	30 lbs.
Rating	20,000 BTU
Heated air outlet diameter	5 in.
Exhaust outlet	1 1/4NPT stainless steel pipe
Combustion air inlet1 in. OD tube
Fuel connection	5/8-18 UNF x 45 deg flare male fitting
Electrical requirements	12 volts DC
Current draw (average, start and run)8 amps
Fuel requirement	Propane (LP gas)
Fuel consumption1 hour/pound on high thermostat setting
Burner	Low pressure type
Ignition	Electronic ignition pack

NOTE

All specifications are based on the use of a vapor-withdrawal gas bottle and gas regulator part number 88301-T. Operation under other fuel conditions voids all warranties. This regulator provides the mandatory pressure (11 inches H2O) required by the calibrated burner head orifice.

Section Two

INSTALLATION INSTRUCTIONS

Pre-Installation Inspection

1. Inspect the heater for damage that may have occurred during shipment. Check against the packing list or invoice for lost parts.
2. Inspect the controls for loose or missing hardware.
3. Inspect all lines, tubing, and fittings to see that they are secure and free of breaks, kinks, or other damage.



Warning

Read all warning tags supplied with the heater. Perform all duties indicated on the tags.

NOTE

A warranty card is packed with each heater leaving the factory. Attached is a return postal card. It is the duty of the dealer to ensure that both the owner's copy and the registration card are completed and the registration card returned to Hunter Manufacturing Company. To be certain that you obtain the benefits of the above warranty, this card should be returned within 10 days from the date you purchased this equipment

Location and Mounting



CAUTION

The heater is designed for use in the horizontal position with the heat exchanger exhaust outlet down. Other permissible positions are those which retain the motor shaft in the horizontal plane. Operation in any other attitude voids all warranties and may result in damage or rapid heater wear unless modified for such use by Hunter Manufacturing Co

The heater is normally installed within the compartment being heated. It can be installed outside the compartment being heated by using a flexible heat duct to direct the heated air into the compartment.

The heater must be shielded against direct contact from rain and snow.



Warning

The tilt switch is a safety device that stops heater operation in case the vehicle overturns. Do not remove this switch or defeat its purpose.

LOCATION AND MOUNTING (cont.)

1. Mount the heater horizontally, as shown in figure 4. Choose a mounting location that will enable mounting the heater on a level surface, with adequate room around the heater for removal and service. Check that the tilt switch is upright. Refer to figure 6 for mounting dimensions and clearances.

2. After selecting a location, remove all combustible material from area, within two inches of where the heater will be located. This includes carpeting, rubber mats, plywood flooring, etc.

3. Cut holes as required for air inlet and exhaust. Remove cross bar and covers. Set heater in place over inlet and exhaust holes and mark mounting holes. Remove heater and drill 5/16 inch diameter holes for mounting studs (page 8)

**CAUTION**

Use heat shield and exhaust collar as described below to prevent damage to paint and furnishings of vehicle from excessive heat.

4. Position heat shield (page 17) around the hole for the exhaust connection, as shown in figure 3. The heater case becomes hot in this area during operation, and the heat shield is required to protect the vehicle from excessive heat. Set the heater over the mounting holes and secure with mounting studs using the nuts and lock washers supplied with the heater.

**Warning**

Exhaust gas must be piped to the outside of the heated compartment. Do not allow the exhaust gas to exit directly beneath the vehicle

5. Direct the exhaust away from the compartment using elbow and nipple , and additional 1 1/4-inch nipples as required. If the exhaust must pass through an additional vehicle body panel or floor, use exhaust collar to protect paint and/or trim. Cut a hole in the panel 2-7/8 to 3 inches in diameter to ensure adequate clearance between the hot pipe and the painted panel and to provide access for later servicing. Cover the opening with exhaust collar and direct the exhaust pipe through it.

6. If the heater is mounted entirely within the cab, connect a 1-inch rubber or plastic hose to the air inlet and run it outside the cab to provide fresh air for combustion.

General Installation

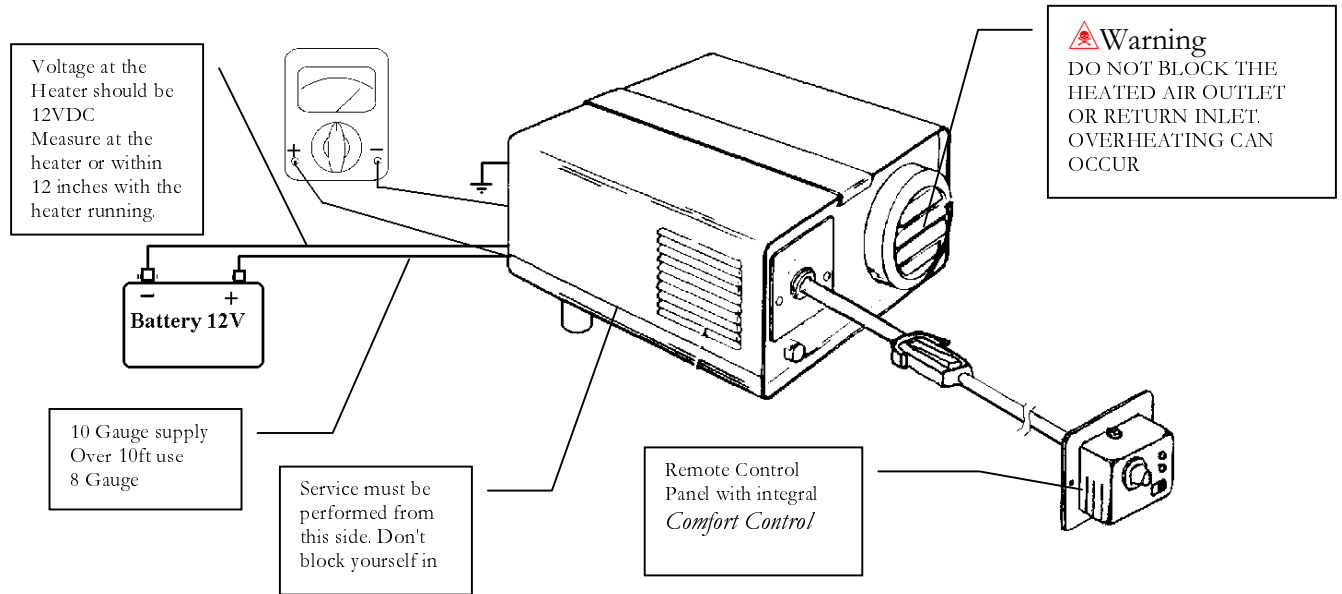

Electrical Requirements (FIG.1)

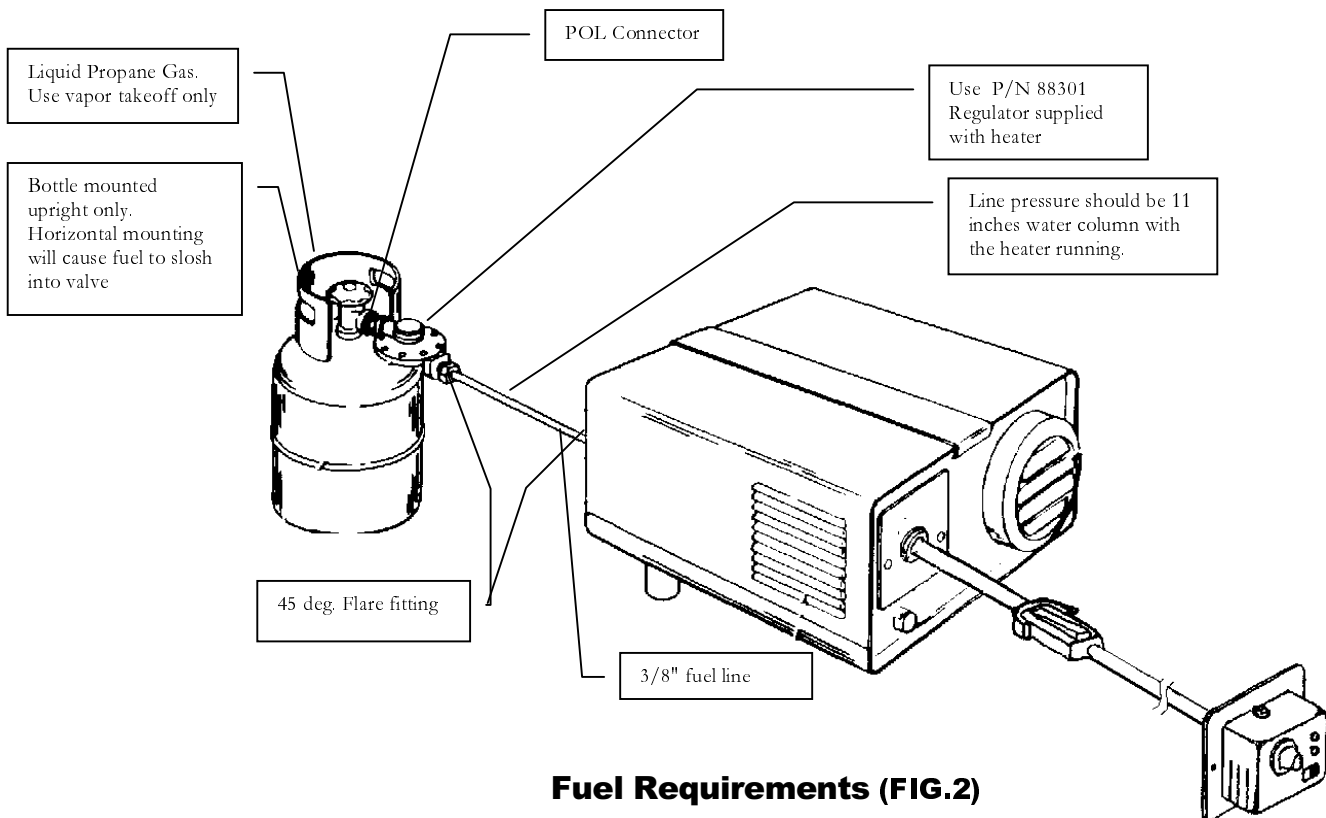

Fuel Requirements (FIG.2)

General Installation

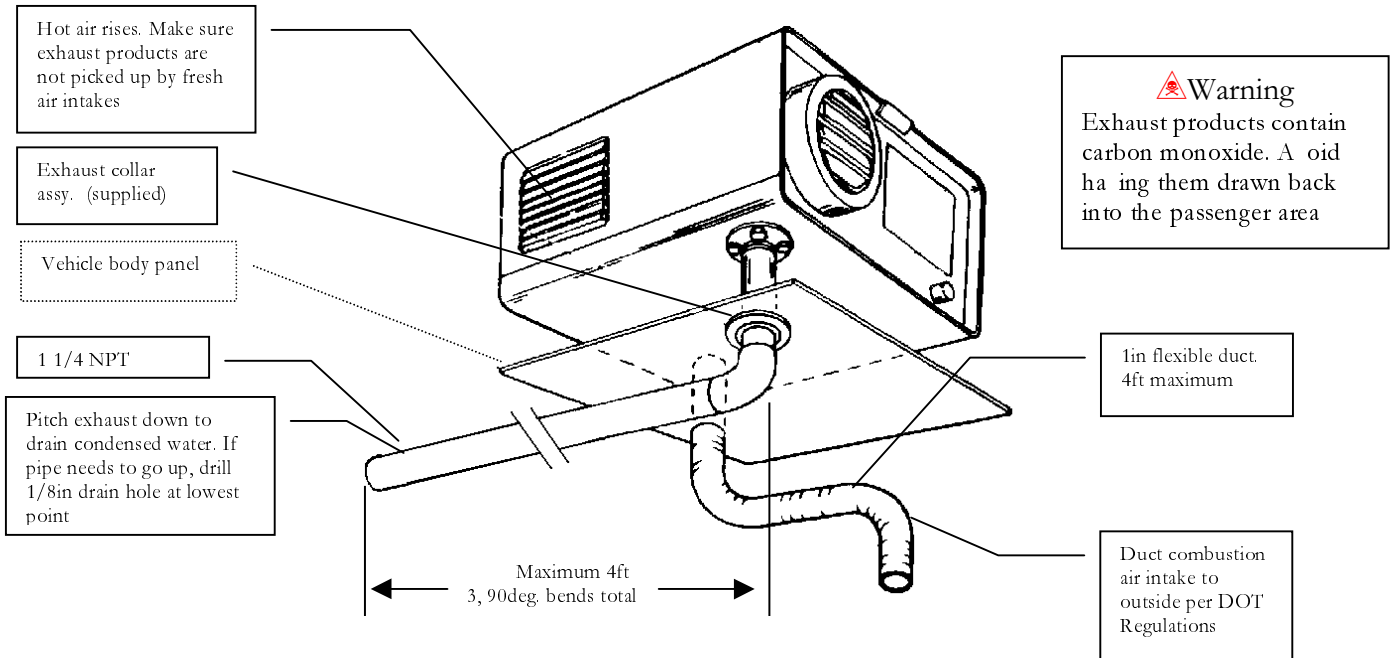

Exhaust and Combustion Air Requirements (FIG.3)

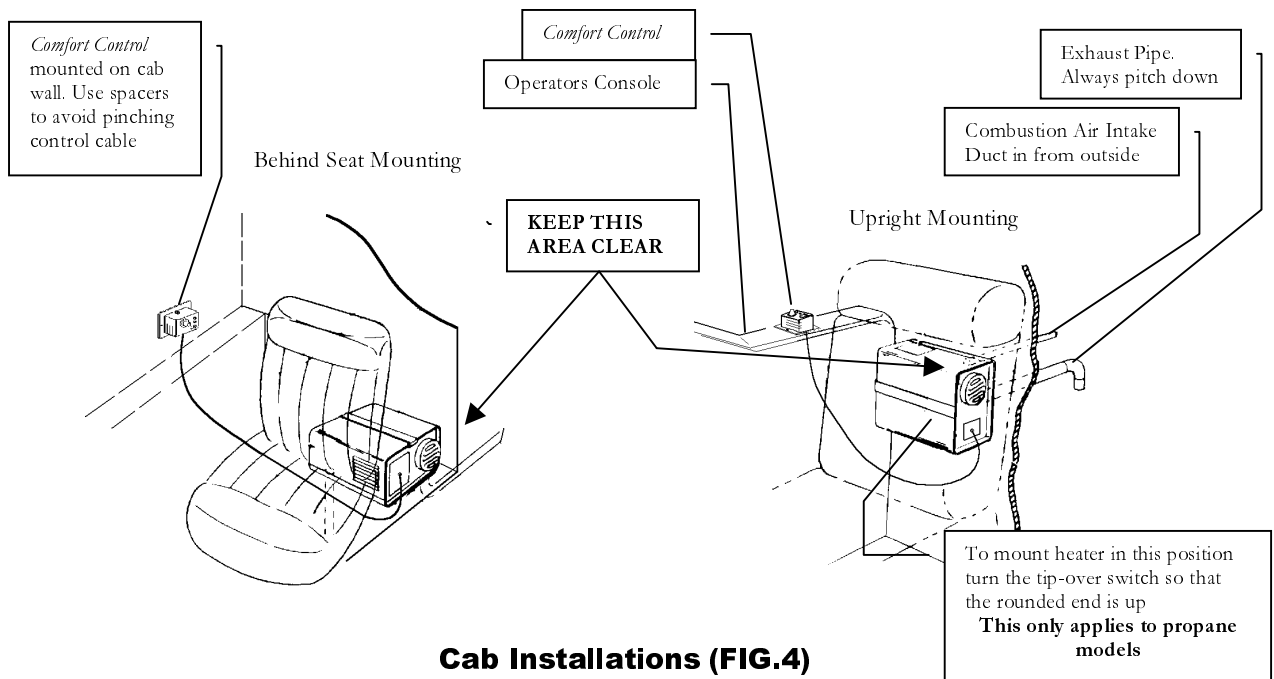

Cab Installations (FIG.4)

General Installation

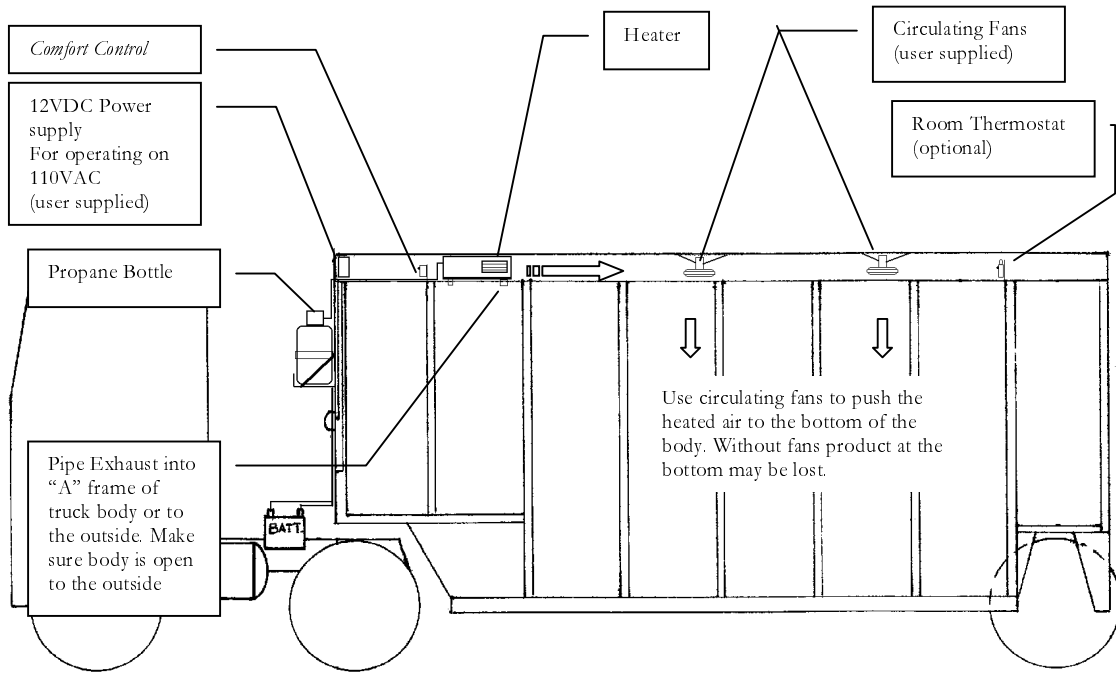

Beverage Body Installation (FIG.5)

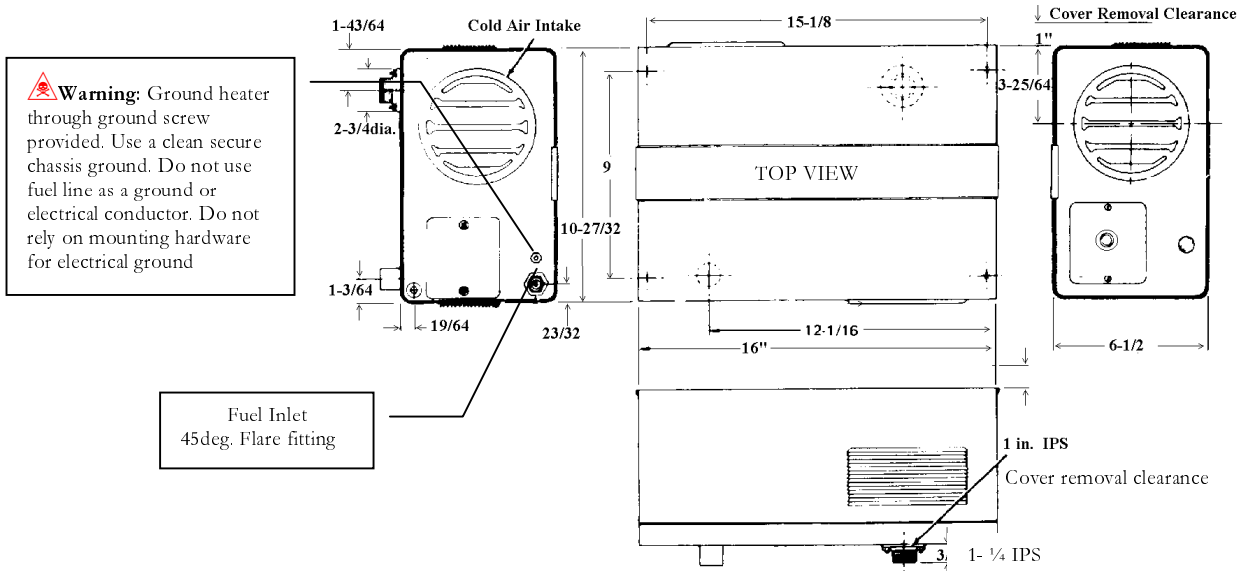

Heater Mounting Dimensions (FIG.6)

Fuel Connections

 **Warning:** This heater is designed for use with propane (LP gas) only. Do not attempt to use gasoline as fuel since fire or explosion may result. Use this heater only with gas regulator part number 88301-T and POL connector part number 88014 supplied with the heater. Operation with other regulators, or tampering with the regulator adjustment, voids all warranties, and may result in fire, explosion or damage to the heater.

1. Locate and mount the propane tank (gas bottle) away from the engine and heater exhaust ports. The location should also protect the tank from accidental mechanical damage.



CAUTION

Use only propane tanks which are designed or modified for vapor withdrawal. Connect the heater to the VAPOR port on the tank. Damage to the heater and regulator will result if connections are not made properly.

2. The propane tank must be a gas bottle designed or modified for vapor takeoff only. Install POL (put on left) connector (fig.2) at the IN port on regulator, and install these assembled parts into the propane tank shutoff valve, as shown in figure 2.



NOTE: POL connector, part number 88014, incorporates an excess flow valve. Use of an excess flow valve is a safety requirement of the Department of Transportation (DOT).

3. Fuel line from the regulator to the heater should be 3/8-inch diameter tube. If available, a short piece of flexible fuel line may be used at the regulator to make bottle changing more convenient. Flexible line must be approved 300-psi test neoprene hose, which can normally be obtained from the propane supplier.



CAUTION

Use of flexible fuel line is recommended. If rigid line is used, it must withstand vehicle vibration, which may cause rigid line to crack.

Electrical Connections

 **Warning:** Ground the heater electrically through the ground screw provided on the heater case, and connect to a clean, secure chassis ground. Do not use the fuel line as a ground or electrical conductor. Use of the fuel line as an electrical or ground conductor can result in fire or explosion. Do not rely on heater mounting studs to provide electrical ground.

1. Refer to the wiring diagram in figure 7, locate the power and ground connections on your heater. The ground terminal is located one inch to the left of the fuel inlet. Connect this terminal to a good, clean chassis ground, using the wire size listed in Table 1.
2. Refer to the wiring diagram and connect the red power lead from the heater fuse to the vehicle electrical system, using the wire size specified in Table 1. This line should be hot at all times, so the heater can purge even if the vehicle ignition is off. Protect the vehicle with a circuit breaker or 10 amp fuse in the feed line.

Length Of Run (feet)	Wire Size
Less Than 10	10 gauge
10 to 30	8 gauge
Over 30	6 gauge

Table 1. Wire Sizes

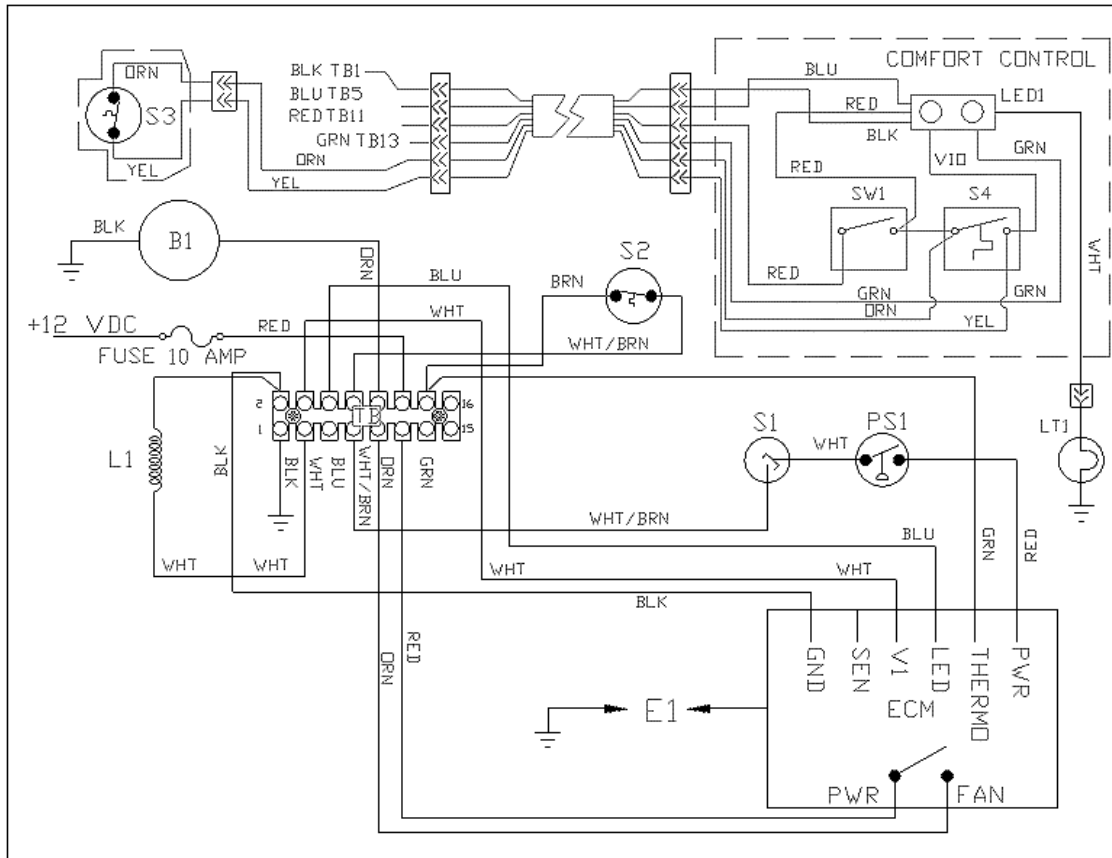

Electrical Diagram PH20-30A (figure 7)

Symbol	Description
B1	Blower Motor
ECM	Electronic Control Module
E1	Igniter
L1	Solenoid Valve
LED1	L.E.D. Assembly
PS1	Pressure Switch
S1	Tilt Switch
S2	Overheat Thermostat
S3	Room Thermostat (optional)
S4	Comfort Control Thermo.
SW1	Main Switch
TB	Terminal Block
LT1	External Diagnostic Light (optional)

Section Three

OPERATION

Controls and Indicators

Comfort Control Assembly

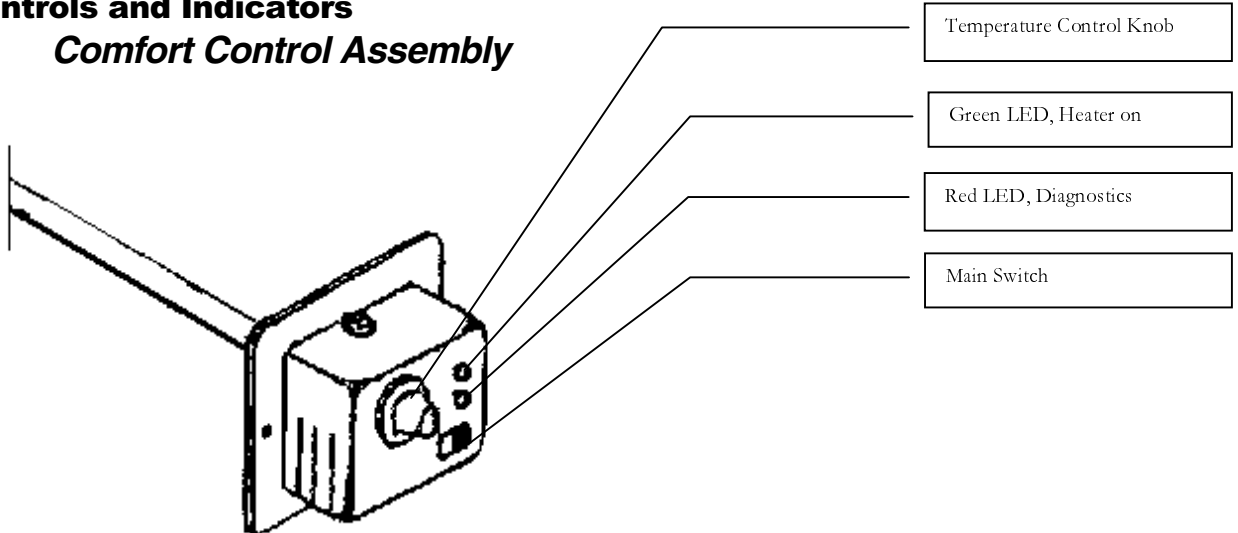

Controls and Indicators (figure 5)

Table 2. Control and Indicator Functions

Name	Function
Main Switch	Simple on/off switch. Move to ON for heater to run. ⚠ Note: Green light will come on but heater will not start until heat is called for by the temperature control or remote room thermostat.
Temperature Control Knob	Controls the temperature in the heated area by way of an internal thermostat. Temperature range is 45-95 degrees F. Turn clockwise to increase. The control has a detent when turned counter clockwise, which locks out this thermostat. This will not shut off the heater (see main switch)
Green LED	Indicates when the heater is on and ready to operate.
Red LED	Indicates when a fault has occurred by flashing a code.
Remote Room Thermostat (not pictured)	An optional calibrated room thermostat kit P/N 51643 can be attached for beverage body or cargo heating.

⚠ Note: When a remote room thermostat and the *Comfort Control* are used together, either one will start the heater, after the main switch is ON.

Theory of Operation

The Falconaire PH20-30A is a Microprocessor Based Direct Spark Ignition, thermostatically controlled heater. The control utilizes a microprocessor to continually and safely monitor, analyze and control the proper operation of the gas burner. Value added features such as combustion blower control, LED diagnostic output, automatic one hour reset, and multiple ignition tries highlight the controls benefits.

OPERATION

POWER UP/STANDBY

When the main power switch is turned on, the control will reset, perform a self check routine, initiate full time flame sensing, and enter the thermostat scan state.

HEAT MODE

When a call for heat is received from the thermostat, the control will check the combustion pressure switch for normally open contacts. The blower is then energized and once the combustion pressure switch contacts close, a 3-second prepurge delay begins. Following the prepurge period, the gas valve is energized and sparks commence for the trial for ignition (TFI) period.

When flame is detected during TFI, sparks are shutoff immediately and the gas valve and combustion blower remains energized. The thermostat, combustion pressure switch, and main burner flame are constantly monitored to assure the system continues to operate properly. When the thermostat is satisfied and the demand for heat ends, the main valve is de-energized immediately, the control senses the loss of flame signal and initiates a 60-second postpurge period before de-energizing the combustion blower.

FAILURE TO LIGHT - LOCKOUT

Should the main burner fail to light, or flame is not detected during the first TFI period, the gas valve is de-energized and the control goes through an interpurge delay before another ignition attempt. The control will attempt two additional ignition sequences before going into lockout. The valve relay will be de-energized immediately, and the combustion blower will be turned off following the post purge period.

Recovery from lockout requires a manual reset by resetting the thermostat, turning off the main power switch or removing 12-volt power for a period of 5 seconds.

If the thermostat is still calling for heat after one hour the control will automatically reset and attempt to ignite the burner again.

Starting

Cab or Crew Area

1. Flip Main switch to ON
2. Rotate *Comfort Control* knob approximately 75% of full travel clock wise.
3. When temperature in the heated area is satisfactory rotate *Comfort Control* knob counter clock wise until a "click" is felt in the knob. Now the cabin temperature is set. The *Comfort Control* will maintain the current temperature. Some adjusting will be necessary until the "perfect" setting is reached.

Cargo or Beverage

1. Flip Main switch to ON
2. Rotate *Comfort Control* knob approximately 50% of full travel clock wise.
3. If using calibrated room thermostat, set it to the desired setting. If this thermostat is to control the heater then set the *Comfort Control* to the lowest setting.
4. Adjust, as necessary to maintain desired temperature.

Heating

The heater will run as long as fuel and power are supplied to it. If the supply voltage is below 9.0VDC when the heater is started then it will go into fault mode. (See fault codes)

As long as the green light is on and the red light is not blinking, the heater is ready to run.

Shutdown

1. Flip Main switch to OFF. The green indicator light should go out immediately.
2. The heater will go into a 60 second postpurge, then shut off.
3. The *Comfort Control* does not have to be turned down. It is recommended for ease of operation that you set it and forget it.

Section Four

TROUBLESHOOTING and DIAGNOSTICS

Fault Codes

The PH20-30A has built in diagnostic capabilities. When the microprocessor-based control detects a fault, it displays an error code by flashing the red LED. To clear an error code, turn off the main switch. (Except for low voltage)

Table 3 Error Codes

Number of Flashes	Problem	Remedy
1 *	Combustion pressure fault. Pressure switch did not close during TFI	Check voltage at heater while running. Check combustion pressure tube between burner head and pressure switch. Check combustion air inlet for blockages. Check motor
2	Flame is detected in the combustion chamber at a time it should not be.	Check solenoid valve for open condition.
3	Burner has failed to ignite after TFI sequence	Check fuel supply.

* The blower will run for approximately 5 minutes before this code is flashed. During this time, the unit will not heat.

Troubleshooting

The diagnostic features of the ECS will cover most problems that you may have with your heater. Table 5 Troubleshooting chart addresses some other problems that may arise

TABLE 5. TROUBLESHOOTING CHART

Trouble	Cause and/or Remedy
Heater fails to start - motor does not run, green light is not on.	<ol style="list-style-type: none"> 1. Check fuse. 2. Check all electrical connections including ground. 3. Check motor. Replace if necessary. 4. Is it turned on?
Heater fails to start - motor does not run, green light is on.	<ol style="list-style-type: none"> 1. Check to see if Comfort Control is turned up

Burner Head Maintenance

The PH20-30A is designed so that the igniter should never have to be replaced. If for some reason the igniter is broken or the burner head requires cleaning and the igniter is removed, the igniter gap should be checked. Set the gap to .125" +.03 -00. It is important that the gap be set correctly for flame ignition and flame sensing.

To set the spark gap:

1. bend the center electrode slightly
2. check with feeler gage between igniter tip and center electrode

NOTE: igniter should not need to be bent. Adjust center electrode only

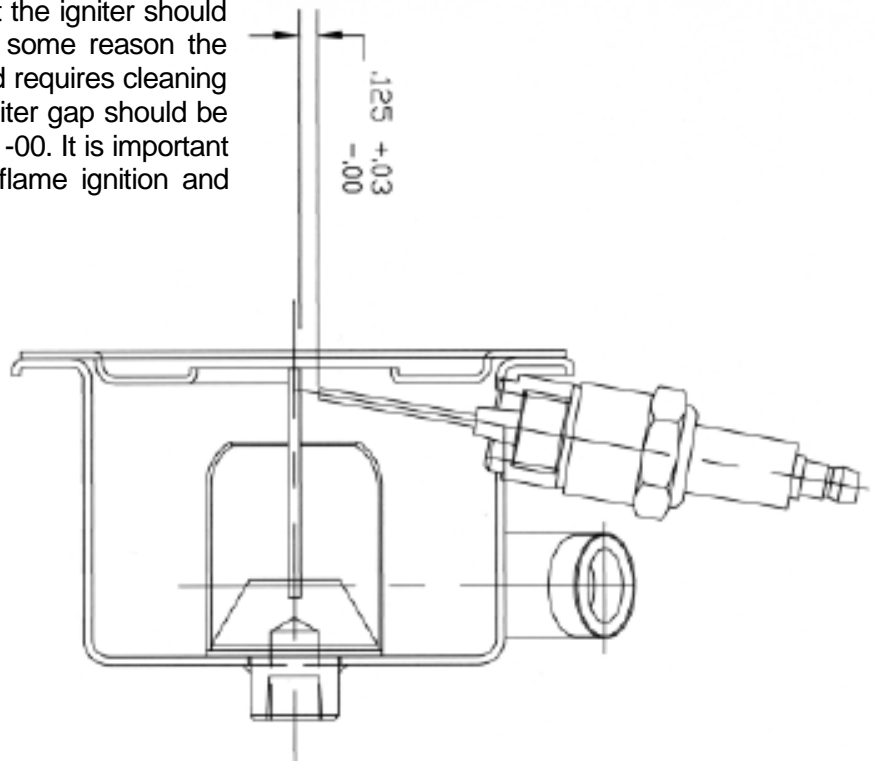

Preseason Maintenance, Annual Service

The following service procedures, if performed as indicated, will help ensure proper operation and extend the life of your heater.

Description	Daily	Weekly	Monthly	Pre-season
Inspect propane tank, regulator, and excess flow valve		*		*
Inspect combustion air inlet for obstructions	*			*
Inspect exhaust pipe for blockages	*			*
Clean combustion blower				*
Oil motor bearings				*
Inspect fuel lines for leaks using leak detector			*	*
Inspect and if necessary tighten mounting hardware				*
Have propane tanks inspected for excess oil, desiccant, water etc.				*
Check electrical connections including ground			*	*
Operate heater during non-heating season			*	*



Service Tip: Use high temp anti-seize compound on burner head screws.

Section Five

PARTS LIST

General

This section lists and illustrates the major parts of your model PH20-30A Hunter heater. In general, attaching parts such as screws, nuts and lock washers have not been listed or illustrated since their application is obvious. If a part has not been assigned a part number, or the abbreviation COML appears, the part can be replaced with a commercially available equivalent.

All available service kits are listed. Parts shown with an asterisk (*) are available only as part of a kit.

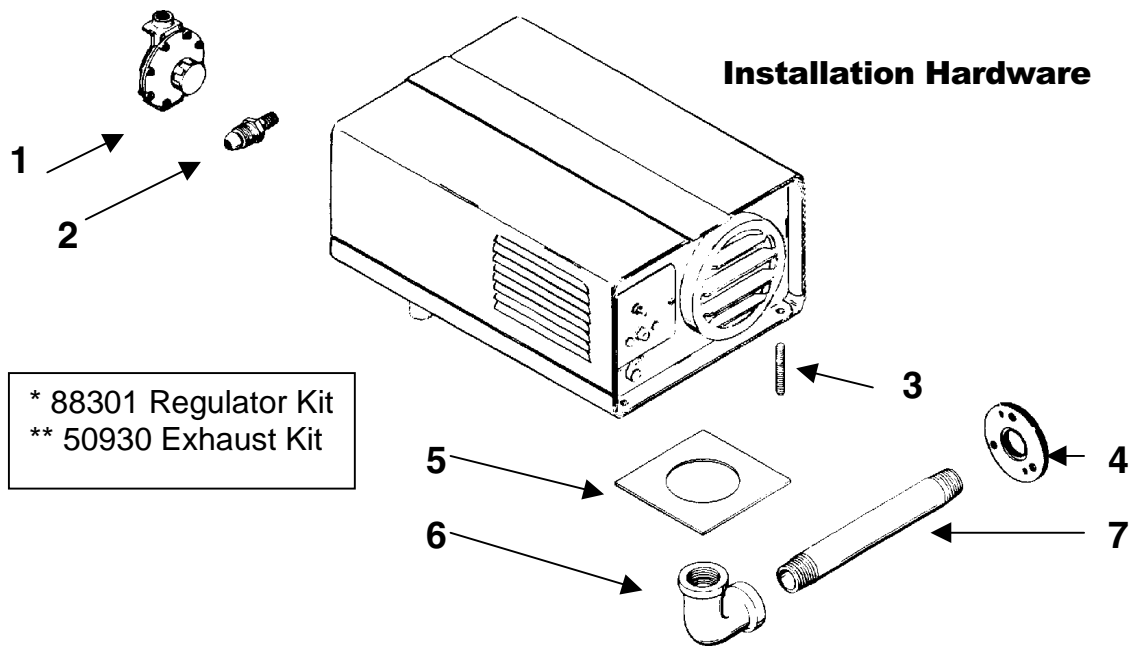

Index Number	Part Number	Description
*1	88301-T	Regulator
*2	88014	POL Conn.
**3	49084	1/4 -20 Stud
**4	51718	Exhaust Collar Assy.
**5	49091	Heat Shield
**6	47006	1 1/4" Pipe Elbow
**7	47008	1 1/4" Pipe X 8"

Case and Heat Exchanger

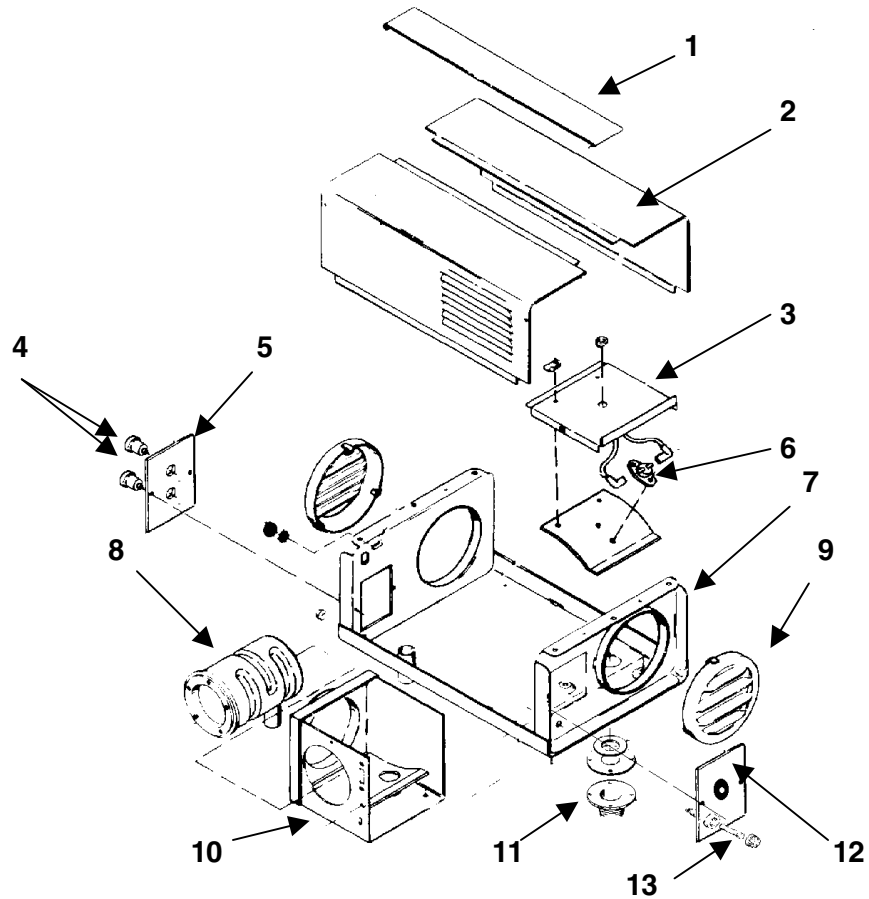

Index #	Part #	Description	Index #	Part #	Description
1	49131	Crossbar	9	50734	Deflector
2	49196	Covers	10	4952201	Brkt. Exch.
3	493151	Top Cover	11	49355	Exhaust Conn.
4	49828	Terminal	12	52745	Panel
5	52712	Panel	13	52632	Fuse Assembly
6	4347	Over Heat Thermostat			
7	52618	Case Assembly			
8	49420	Heat Exchanger			

 Note: To get complete set order two 49196 covers.

Fuel, Ignition, and Electronic Control System

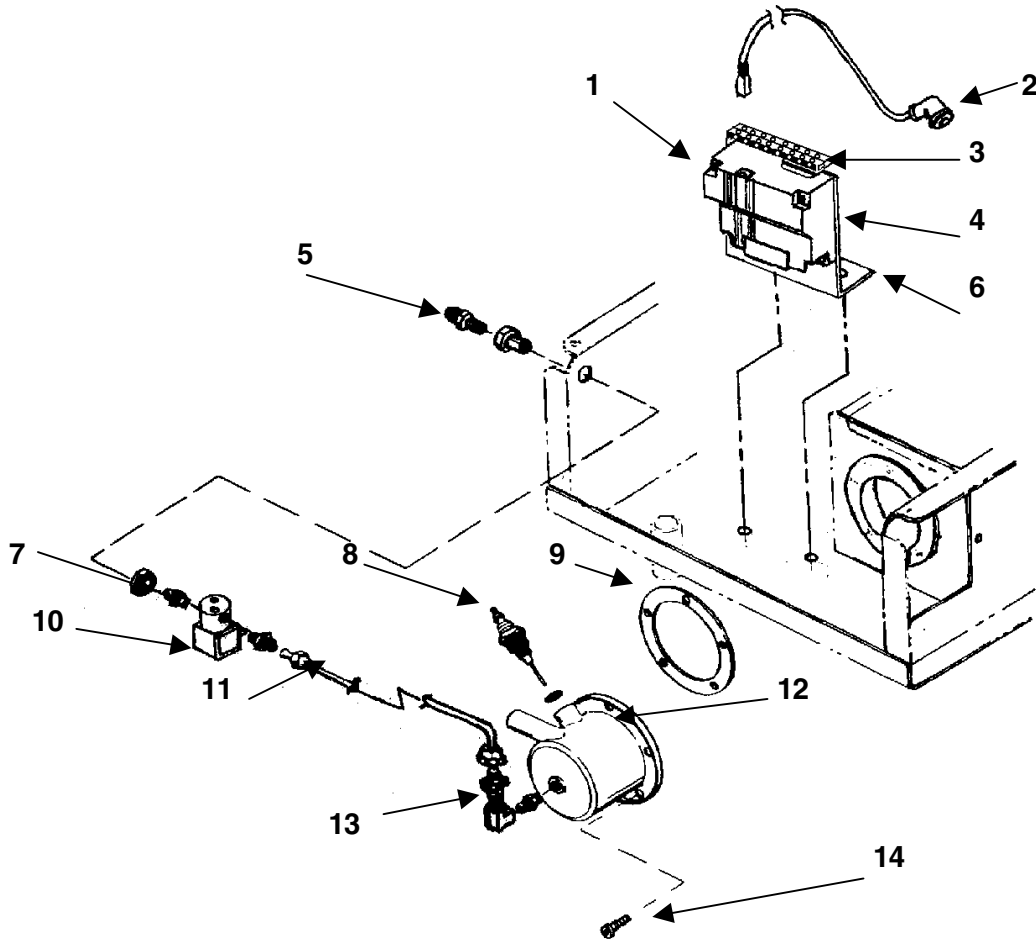

Index #	Part #	Description
1	52610	Electronic Control Module
2	52610-4	Ignition Cable
3	51964	Terminal Block
4	52611	Pressure Switch (not Shown)
5	3629	45° Flare Fitting
6	52608	Mounting Bracket
7	13819	1/8 NPT Connector
8	4718201	Igniter and Gasket
9	49093	Burner Head Gasket
10	50386	Solenoid Valve
11	52606	Fuel Line
12	52604	Burner Head
13	50716	Restrictor Assembly
14	COML	10-24NC Cap Screw

Blower and Motor Assembly

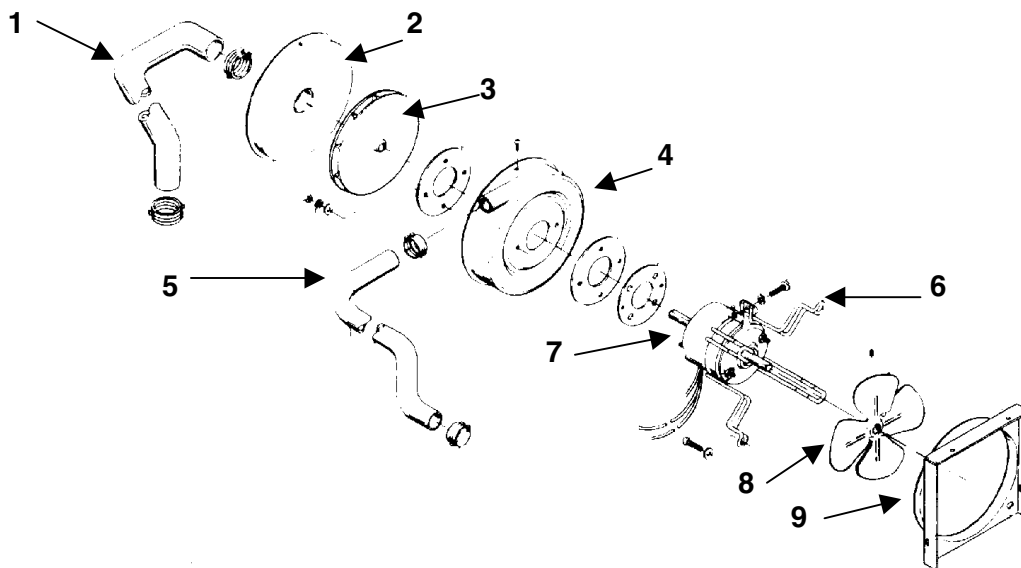

Index #	Part #	Description
1	10599-07	Inlet Air Duct
2	50875	Cover
3	51567	Combustion Blower Wheel
4	50576	Combustion Blower Housing
5	49152	Combustion Air Hose
6	50783	Motor Mount
7	49226	Motor (12VDC)
8	49976	Prop Fan
9	49399	Mounting Plate
* 5158212	Complete Blower and Motor Assembly	

Comfort Control and Remote Harness

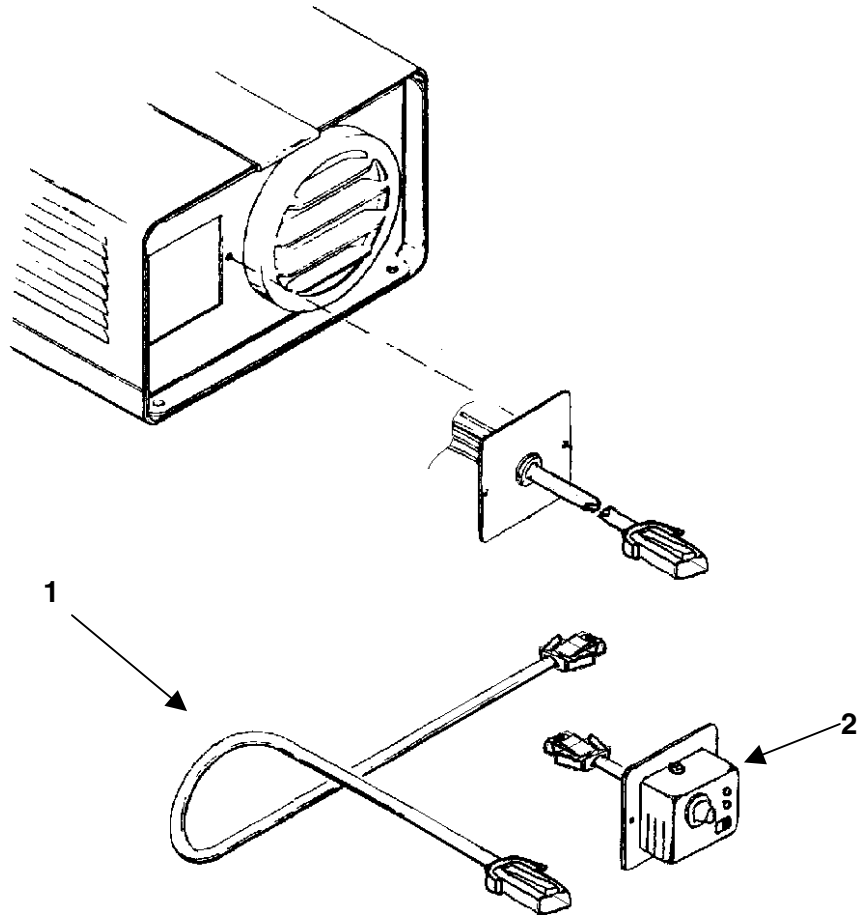

Index #	Part #	Description
1	52944-6	Remote Cable 6ft
2	52621	Comfort Control Assembly complete
*		L.E.D. Circuit
*	52623	Thermostat
*	52624	Knob
*		Main Switch
*		Control Harness

* Part of 52621 Comfort Control

Section Six

OPTIONS and ACCESSORIES

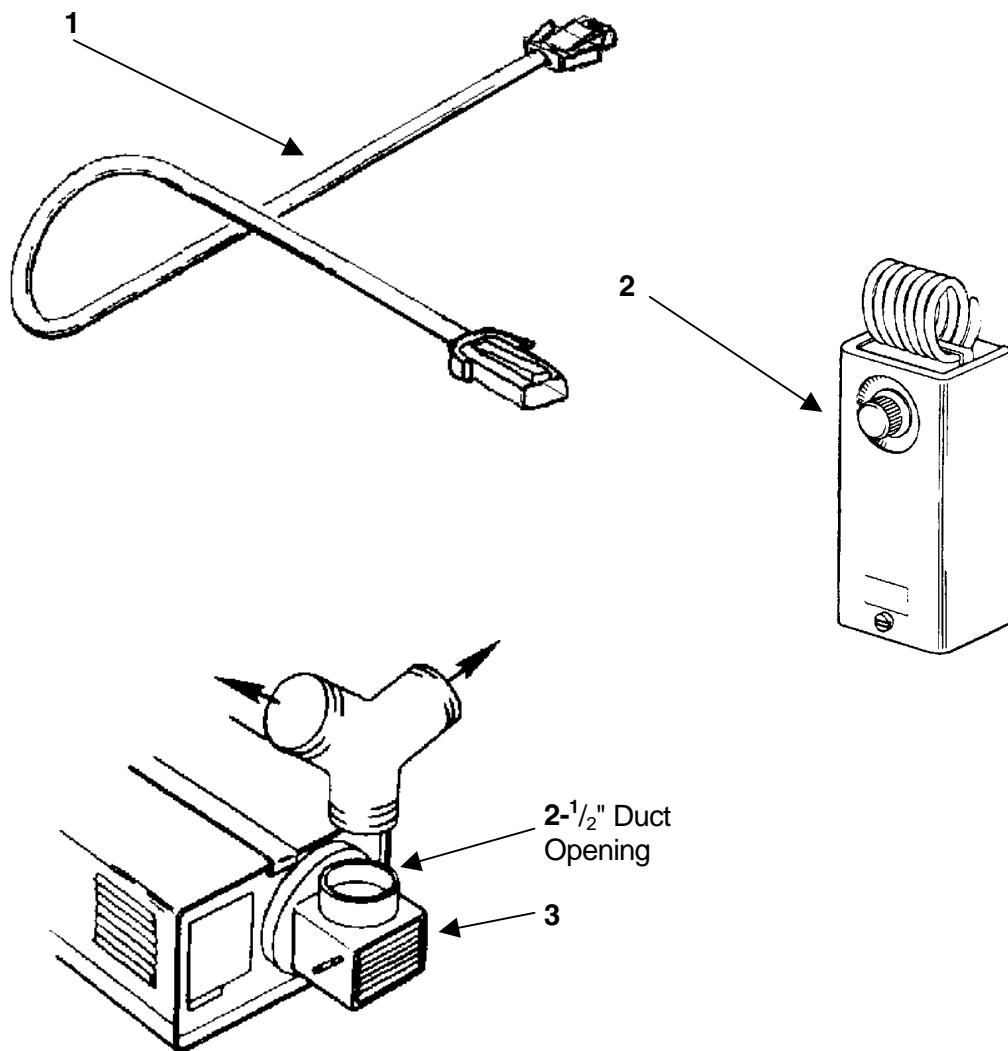

Index #	Part #	Description
1	52944-10	10 Foot Long Remote Cable
	52944-20	20 Foot Long Remote Cable
2	51643	Thermostat, Calibrated
3	47060	Defroster Kit ("y" not included)

Remote Calibrated Thermostat Installation

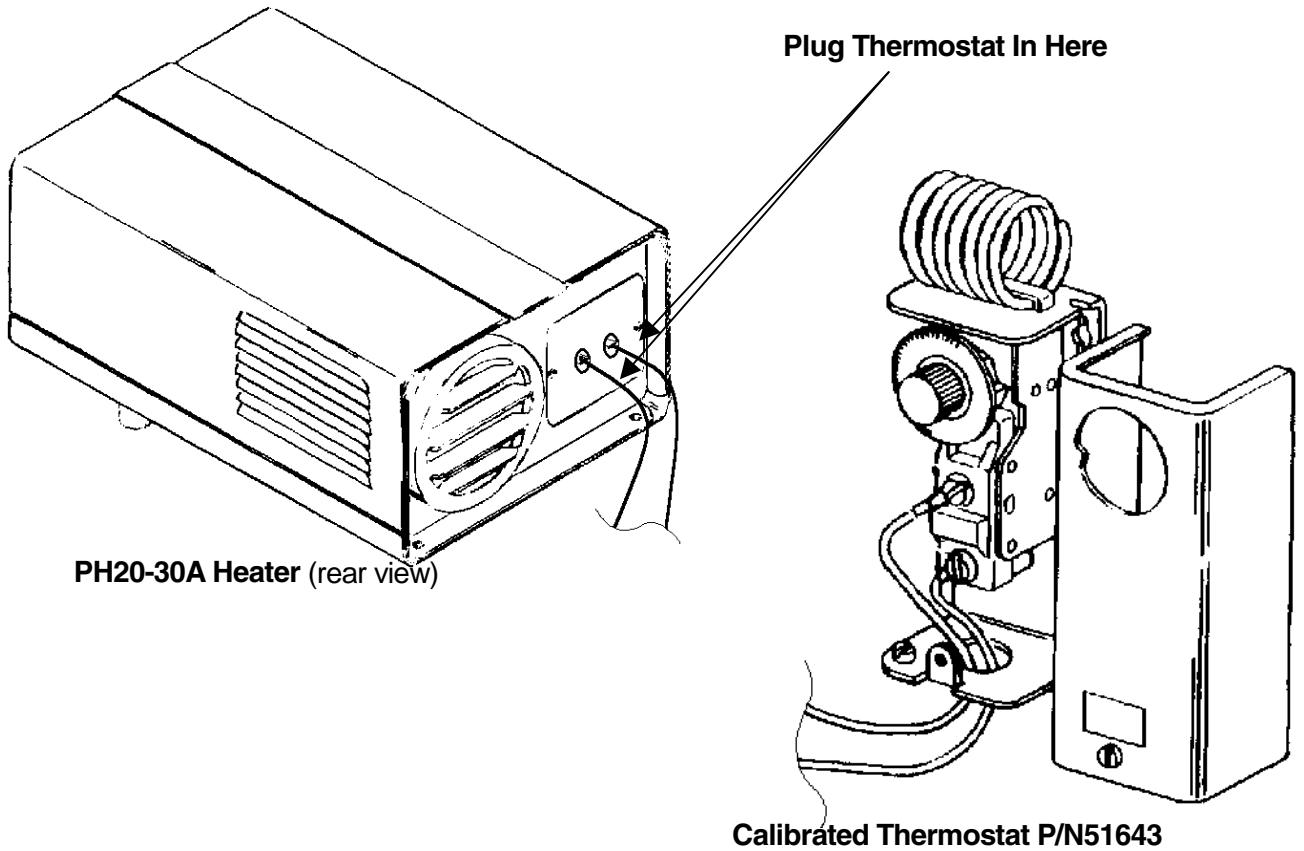

Plug the remote thermostat into the rear of the heater using the spade connectors supplied. Use 20ga wire.

External Diagnostic Light Installation

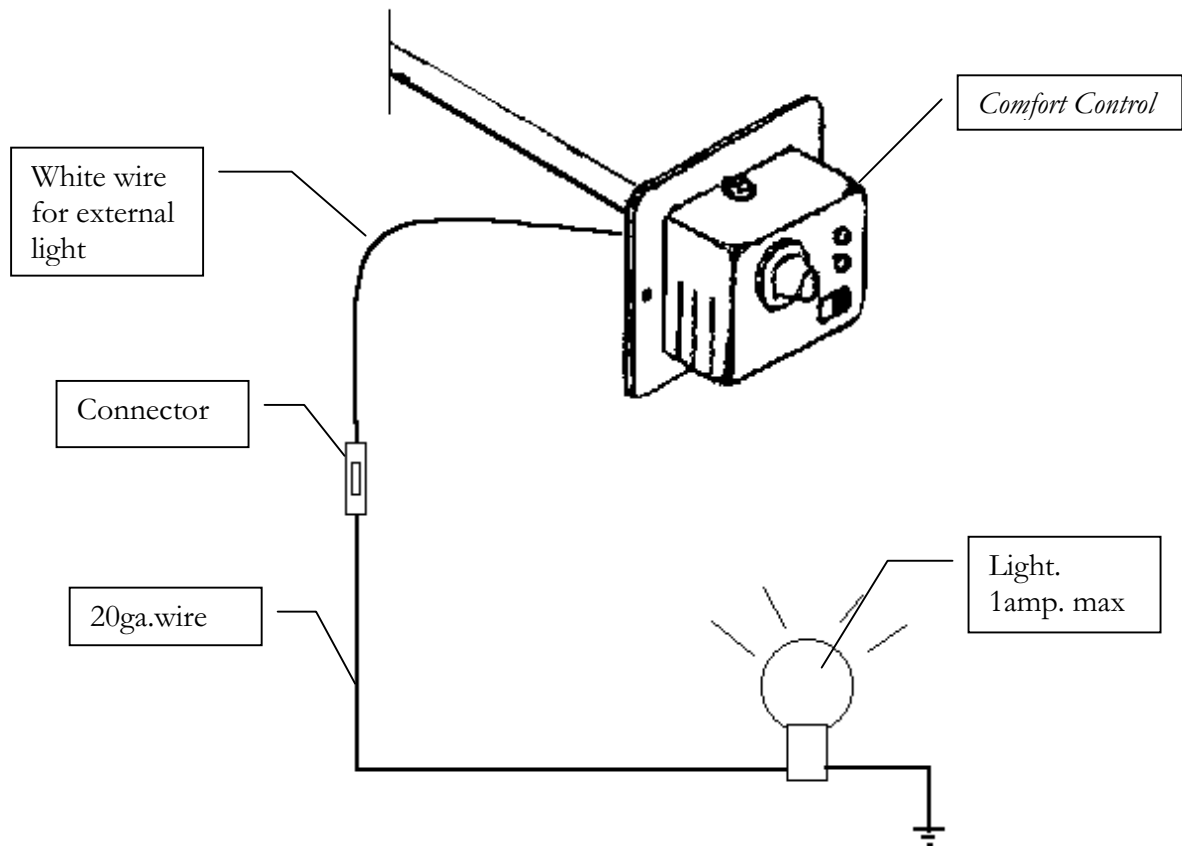

The Ph20-30A comes with an additional power lead on the back of the *Comfort Control* to attach a remote or external diagnostic light. On some applications, it is necessary to monitor the heater operation from outside the vehicle. This circuit will handle **1 amp maximum**. Attach one power lead (positive) to the connector on the *Comfort Control*. The negative lead may be attached to chassis ground or heater ground. Use 20ga wire when making connections.

The remote light circuit operates on the inverse of the red LED. That is to say that when the red LED is off the remote light is on. This allows you to monitor normal heater operation. For example, when the heater is turned on, and is running normally the remote light will be on. When a fault code is flashed, the remote light will blink along with the red LED.