



SHERWOOD INDUSTRIES IS AN ENVIRONMENTALLY RESPONSIBLE COMPANY. THIS MANUAL IS PRINTED ON RECYCLED PAPER.

PLEASE KEEP THESE INSTRUCTIONS FOR FUTURE REFERENCE



EG40 BV

BY: SHERWOOD INDUSTRIES LTD

OWNER'S MANUAL



WHAT TO DO IF YOU SMELL GAS

- Open windows/Extinguish any open flame.
- Do not try to light any appliance.
- Do not touch any electrical switch or use any phone in your building.
- Immediately call your gas supplier from a neighbour's phone. Follow the gas supplier's instructions.
- If you cannot reach your gas supplier, call the fire department.

This appliance may be installed in an after market permanently located, manufactured (mobile) home, where not prohibited by local codes.

This appliance is only for use with the type of gas indicated on the rating plate. This appliance is not convertible for use with other gases, unless a certified kit is used.

WARNING

If the information in this manual is not followed exactly, a fire or explosion may result causing property damage, personal injury or loss of life. Installation and service must be performed by a qualified installer, service agency or the gas supplier.

FOR YOUR SAFETY

Do not store or use gasoline or other Flammable vapours and liquids in the vicinity of this or any other appliance.



Massachusetts installations (Warning): This product must be installed by a licensed plumber or gas fitter when installed within the Commonwealth of Massachusetts. Other Massachusetts code requirements:-Flexible connector must not be longer than 36 inches, shut off valve must be a "T" handle gas cock, only direct vent sealed combustion products are approved for bedroom/bathrooms, fireplace dampers must be removed or welded in the open position prior to the installation of a fireplace insert or gas log.

EG40-071

SAFETY PRECAUTIONS

FOR SAFE INSTALLATION AND OPERATION OF YOUR “ENVIRO” HEATER, PLEASE CAREFULLY READ THE FOLLOWING INFORMATION:

- All ENVIRO gas-fired appliances must be installed in accordance with their instructions. Carefully read all the instructions in this manual first. Consult the building authority having jurisdiction to determine the need for a permit prior to commencing the installation.
- **NOTE:** Failure to follow these instructions could cause a malfunction of the fireplace, which could result in death, serious bodily injury, and/or property damage.
- Failure to follow these instructions may also void your fire insurance and/or warranty.

GENERAL

- Installation and repair should be done by a qualified service person. The appliance should be inspected before the first use and, annually thereafter by a qualified service person. More frequent cleaning may be required due to excessive lint from carpeting, bedding material, etc. It is imperative the control compartments, burners and circulating air passageways of the appliance be kept clean.
- Due to high temperatures, the appliance should be located out of high traffic areas and away from furniture and draperies.

Children and adults should be alerted to the hazards of high surface temperatures and should stay away to avoid burns or clothing ignition.

Young children should be carefully supervised when they are in the same room as the appliance.

FOR YOUR SAFETY

- Installation and service must be performed by a qualified installer, service agency or gas supplier.
- This installation must conform to local codes or, in the absence of local codes, to the current CAN/CGA-B149 installation code (Canada) or National Fuel Gas Code ANSI Z223.1.2 (USA).
- To prevent injury, do not allow anyone who is unfamiliar with the stove to operate it.

• To prevent injury, if the pilot or pilot and burners have gone out on their own, open the glass door and wait 5 minutes to air out before attempting to re-light the stove.

- Always keep the area around this appliance clear of combustible material, gasoline and other flammable liquids and vapours.
- This appliance should not be used as a drying rack for clothing or for hanging Christmas stockings/decorations.
- Due to the paint curing on the stove, a faint odor and slight smoking will likely be noticed when the stove is first used. Open a window until the smoking stops.

Always connect this gas stove to a vent system and vent to the outside of the building envelope. Never vent to another room or inside the building. Make sure the specified vent pipe is used; properly sized and of adequate height to provide sufficient draft. Inspect the venting system annually for blockage and signs of deterioration.

WARNING: Failure to position the parts in accordance with the diagrams in this booklet, or failure to use only parts specifically approved with this appliance may result in property damage or personal injury.

WARNING: Do not operate with the glass front removed, cracked or broken. Replacement of the glass must be done by a licensed or qualified service person.

- Never use solid fuels such as wood, paper, cardboard, coal, or any flammable liquids, etc., in this appliance.
- Do not use this heater if any part has been under water. Immediately call a qualified service technician to inspect the heater and to replace any part of the control or gas control systems that have been under water.
- Do not abuse the glass by striking it or slamming the door shut.

TABLE OF CONTENTS

Safety Precautions.....	2
Table of Contents.....	3
Codes And Approvals.....	4
Specifications.....	5
Dimensions.....	5
Clearances to Combustibles.....	5
Preparation For Installation.....	5
Initial Installation.....	6
Venting.....	6
Flue Gas Spill Switch.....	6
Manufacturer’s General Venting Guidelines.....	6
General Venting For The EG40.....	6
Termination.....	7
Installation Into An Existing Chimney.....	7
Straight Vertical Installation.....	8
Electrical Requirements.....	9
Replacing The Blower.....	10
Adjusting The Venturies.....	10
Fuel Conversion.....	11
Gas Line Connection and Testing.....	12
Secondary Installation.....	13
Installation of Log Set and Embers.....	13
Operating Instructions.....	15
Lighting Instructions.....	15
Turning Gas Off To Appliance.....	15
Routine Maintenance and Service.....	16
Trouble Shooting.....	17
Parts List.....	18
Parts Diagram - Chassis.....	20
Parts Diagram - Gas Tray & Door.....	21
Warranty.....	22
Installation Data Sheet.....	23

CODES AND APPROVALS

BV: This Vented appliance draws all of its combustion air from the dwelling and must be vented using listed B or L vent. May also be vented through a conventional chimney using a chimney liner kit.

This appliance has been tested and approved for installations from 0 feet to 2000 feet (610 m) above sea level.

In the USA: The appliance may be installed at higher altitudes. Please refer to your American Gas Association guidelines which state: the sea level rated input of Gas Designed Appliances installed at elevations above 2000 feet (610 m) is to be reduced 4% for each 1000 feet (305 m) above sea level. Refer also to local authorities or codes which have jurisdiction in your area regarding the de-rate guidelines.

In Canada: When the appliance is installed at elevations above 4500 feet (1372 m), the certified high altitude rating shall be reduced at the rate of 4% for each additional 1000 feet (305 m).

- This appliance has been tested by INTERTEK (**Warnock Hersey**) and found to comply with the established VENTED GAS FIREPLACE HEATER standards in CANADA and the USA as follows:

VENTED GAS FIREPLACE HEATER (EG40 BV NG/LPG)

TESTED TO: ANSI Z21.88a-2003/CSA 2.33a-2003 VENTED GAS FIREPLACE HEATERS
CAN/CGA 2.17-M91 GAS FIRED APPLIANCES FOR HIGH ALTITUDES
CSA P.4.1-02 TESTING METHOD FOR MEASURING ANNUAL FIREPLACE EFFICIENCY

This ENVIRO EG40 BV Fireplace:

- Has been certified for use with either natural or propane gases. (See rating label.)
- Is not for use with solid fuels.
- Is approved for bedroom or bed sitting room. (**IN CANADA:** must be installed with a listed wall thermostat. **IN USA:** see current ANSI Z223.1 for installation instructions.)
- Must be installed in accordance with local codes. If none exist, use current installation code CAN/CGA B149 in Canada or ANSI Z223.1/NFPA 54 in the USA.
- Must be properly connected to an approved venting system and not connected to a chimney flue serving a separate solid-fuel burning appliance.
- Are approved for installation on combustible materials (i.e. Wood, carpet or linoleum).
- Is not approved for closet or recessed installations.

IMPORTANT NOTICE (Regarding first fire up): When the unit is turned on for the first time, it should be turned onto high without the fan on for the first 4 hours. This will cure the paint, logs, gasket material and other products used in the manufacturing process. It is advisable to open a window or door, as the unit will start to smoke and can irritate some people. After the unit has gone through the first burn turn the unit off including the pilot, let the unit get cold then remove the glass door and clean it with a good gas fireplace glass cleaner, available at your local ENVIRO dealer.

NATIONAL
FIREPLACE
INSTITUTE



CERTIFIED

www.nficertified.org

We recommend that our gas hearth products be installed and serviced by professionals who are certified in the U.S. by the National Fireplace Institute® (NFI) as NFI Gas Specialists.

SPECIFICATIONS

WARNING:

Operation of this heater when not connected to a properly installed and maintained venting system can result in carbon monoxide (CO) poisoning and possible death.

DIMENSIONS:

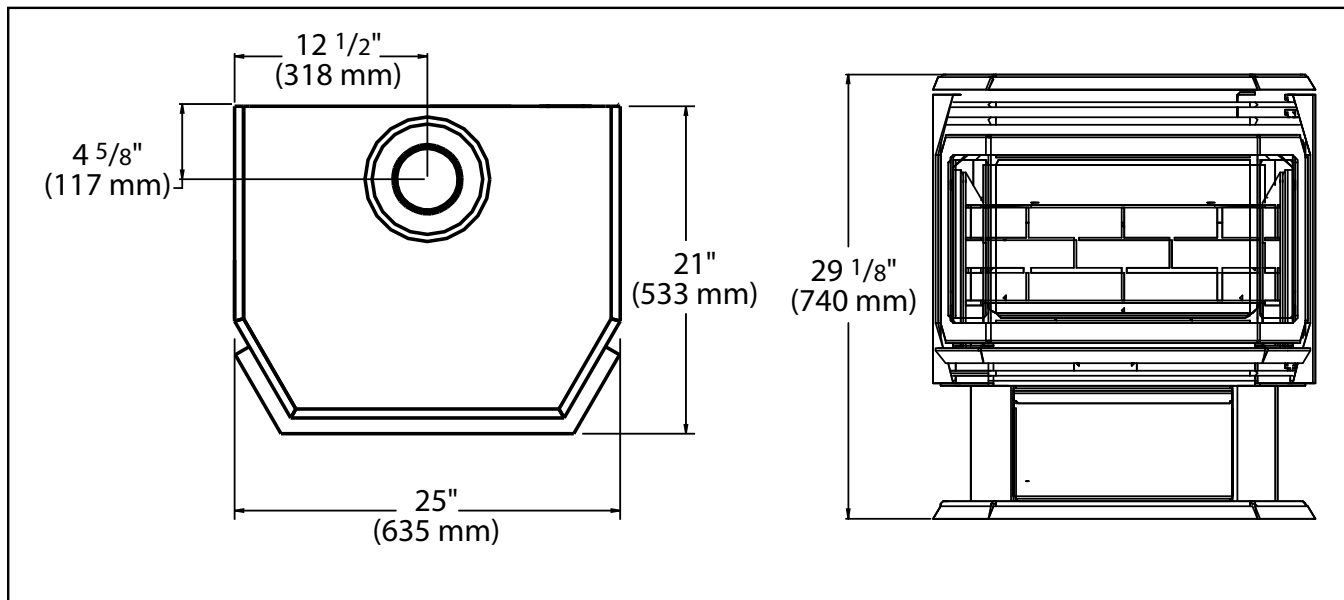

Figure 1: EG40 Exterior Dimensions.

CLEARANCES TO COMBUSTIBLES:

A. Sidewall to unit	12 inches (30.5 cm)
B. Backwall to unit	4 inches (10.2 cm)
C. Corner to unit	2 inches (5.1 cm)
D. Combustibles to unit top	36 inches (91.4 cm)
E. Floor to unit	0 inches
F. Alcove maximum depth:	48 inches (121.9 cm)

- Locate a position where the flue system of the stove can be properly installed without damaging the integrity of the building; e.g. cutting a wall or ceiling joist.
- Check stove and flue system clearance requirements.
- Locate the stove where it can be accessed by a gas supply line.
- Locate the stove in a large and open room that is centrally located in the house. This will optimize heat circulation and comfort.
- As the stove is equipped with a convection fan, ensure that an electrical outlet is within 6 feet. (1.8 m) of the stove.
- The flow of combustion and ventilation air must not be obstructed.

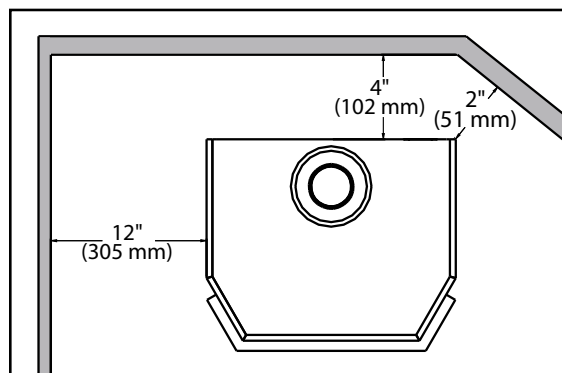

Figure 2: Clearances to combustibles.

CLEARANCES MUST BE SUFFICIENT TO ALLOW ACCESS FOR MAINTENANCE AND SERVICE.

PREPARATION FOR INSTALLATION:

- Remove the packaging from the appliance, and check to make sure there is no damage. If damage is found, please report it to both the carrier and your dealer as soon as possible.
- Before beginning, carefully check the glass door and the log set

INITIAL INSTALLATION

QUALIFIED INSTALLERS ONLY

VENTING:

This model must have a vent opening in the rear of the unit. Confirm this and also check that the label on the right side panel door states "Vented Room Heater".

WARNING: This appliance has been designed to operate by drawing combustion air and dilution air from the room. The draft hood located in the same atmospheric pressure zone as the combustion air inlet to the appliance. It is also designed to draw room air for proper heat circulation from the rear of the unit. Blocking or modifying the louvers in any way can create hazardous situations, either through poor venting or by overheating. It is important that this unit has sufficient air circulation for proper venting and combustion thus provisions must be made for the supply of adequate combustion and ventilation air.

WARNING: Operation of this heater when not connected to a properly installed and maintained venting system or tampering with the vent safety shutoff system can result in carbon monoxide (CO) poisoning and possible death.

**THE APPLIANCE CANNOT BE CONNECTED TO A CHIMNEY FLUE SERVICING
A SEPARATE SOLID FUEL BURNING APPLIANCE.**

FLUE GAS SPILL SWITCH:

NOTE: This heater must be properly connected to a venting system. This heater is equipped with a vent safety shutoff system designed to protect against improper venting of combustion products. This safety switch is located on the rear of the appliance close to the draft hood relief opening.

If the switch trips more than once, the chimney should be inspected by a qualified service technician for possible blockage or severe down draught conditions.

MANUFACTURER'S GENERAL VENTING GUIDELINES:

This information is compiled by the manufacturer as a very general rule for single appliance venting of the EG40 gas stove with 4 inch Type B gas vent. Refer to the Venting manufacturer's directions for installation.

Venting code and regulations may vary from area to area, please check with the local, state/provincial codes regarding the suitability of your application.

For other special venting requirements, please refer to the local, state/provincial or national codes.

The venting system should be assembled and installed according to the vent manufacturer's instructions and the local, state/provincial or national codes.

GENERAL VENTING FOR THE EG40:

This stove should be vented by certified 4" (10 cm) Type B Gas Vent or a flexible gas vent liner that may be encased in 6" (15 cm) decorative stove pipe. The flue collar of the appliance will fit inside of standard vent and may be fastened directly to the vent.

The ENVIRO incorporates its own internal draft hood, so no additional external draft hood is required.

Check periodically that the vent is unrestricted and an adequate draught is present when the unit is in operation.

INITIAL INSTALLATION

QUALIFIED INSTALLERS ONLY

TERMINATION:

The bottom of the vent cap shall extend at least 2 feet (0.61 m) above the highest point of the roof where it passes through and at least 2 feet (0.61 m) higher than any portion of the roof within a horizontal distance of 10 feet (3.1 m).

See vent manufacturer's instructions for vent system clearances to combustibles and vent terminal clearance from roof.

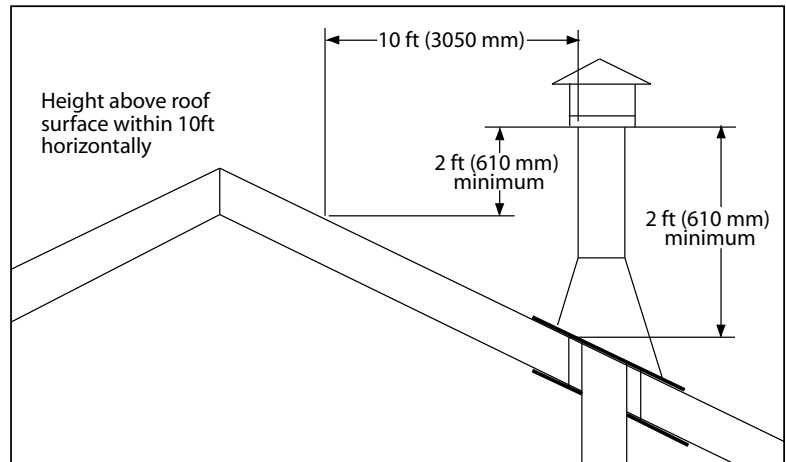

Figure 3: Height of Vertical Termination.

INSTALLATION INTO AN EXISTING CHIMNEY:

This basic venting configuration shown are rough guidelines only. Follow national and local codes for other installation options.

Measure the height of the chimney beforehand and purchase the appropriate kit. Never attempt to over stretch a flexible liner to accommodate the height of the chimney.

- Any flue damper must be removed or locked permanently in the open position.
- The chimney must be clean, in good working order and constructed out of non-combustible materials.
- Make sure that all chimney clean-outs are tightly fitting and will not permit air to leak into the chimney.
- Make all gas connections and check for leaks.

See vent manufacturer's instructions for vent system clearances to combustibles and vent terminal clearance from roof.

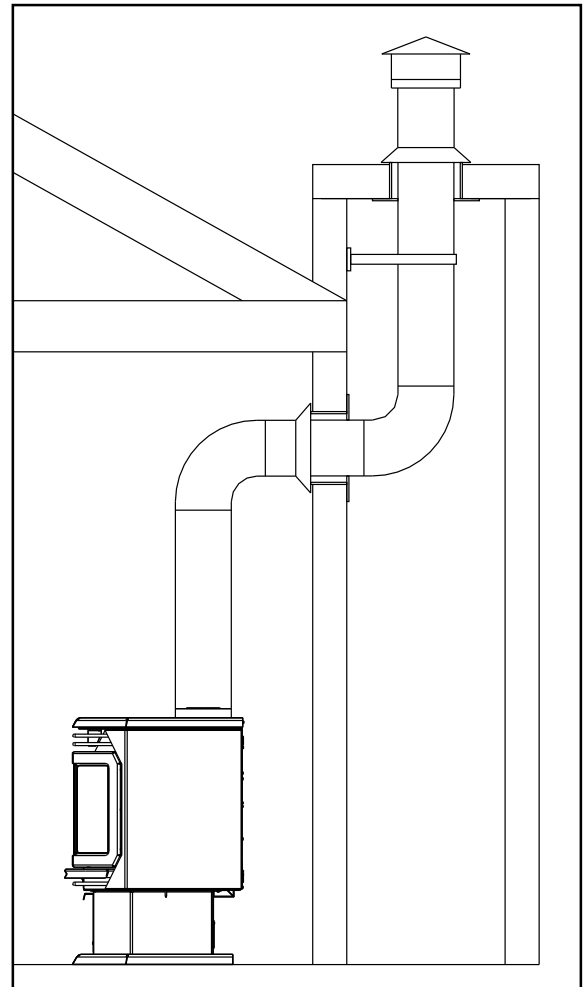

Figure 4: Installation into an existing chimney.

INITIAL INSTALLATION

QUALIFIED INSTALLERS ONLY

STRAIGHT VERTICAL INSTALLATION:

This basic venting configuration shown are rough guidelines only. Follow national and local codes for other installation options.

For the best venting performance, we recommend a total vent height in the range of 10 feet (3.0 m) to 30 feet (9.1 m). The total horizontal length depends on the number of elbows used; a 90° elbow accounts for 5 feet (1.5 m) of the horizontal run.

The venting should never slope down, a minimum ¼ inch (0.6 cm) rise is needed for every 2 feet (61 cm) of horizontal is recommended.

If practical, it is best to locate the appliance to permit the use of shorter horizontals and fewer elbows.

Table 1. 90° elbows allowed verses the horizontal length.

Number of 90° elbows	Maximum total horizontal length allowed
2	20 feet (6.1 m)
3	13 feet (4.0 m)
4	6 feet (1.8 m)
5	0 feet (0 m)

Note: Using two (2) 45° elbows is equivalent to using one (1) 90° elbow.

The venting rise should be a minimum of 1 foot (0.31 m) from the top of the unit before any horizontal run are used.

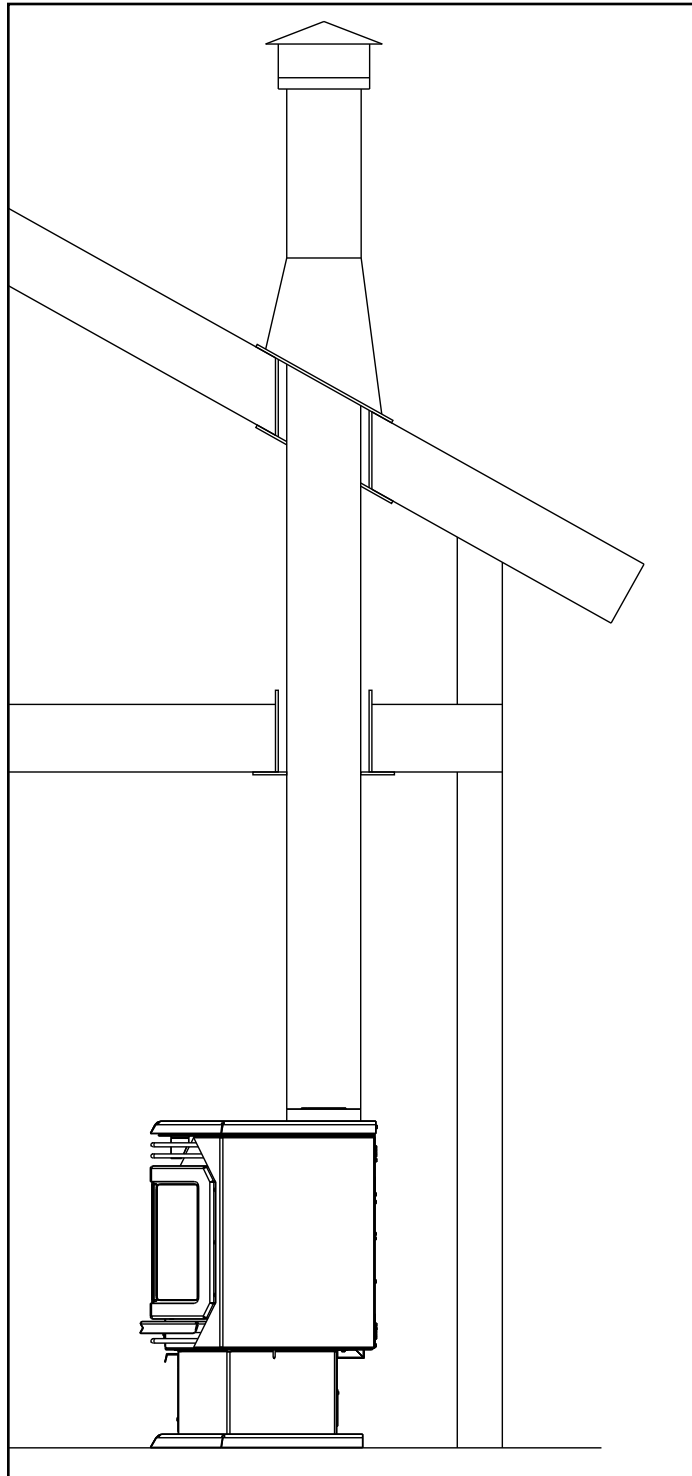

Figure 5: Straight vertical installation.

INITIAL INSTALLATION

QUALIFIED INSTALLERS ONLY

ELECTRICAL REQUIREMENTS:

The **ENVIRO** EG40 will operate without electrical power. This model has a millivolt gas control, which uses the pilot flame to generate enough electricity to operate the main burners. The appliance is equipped with a blower and must be electrically connected and grounded in accordance with local codes or in the absence of local codes, with the current CSA C22.1 CANADIAN ELECTRICAL CODE Part 1, SAFETY STANDARDS FOR ELECTRICAL INSTALLATIONS, OR THE NATIONAL ELECTRICAL CODE ANSI / NFPA 70 in the U.S.

WARNING: Electrical grounding instructions. This appliance is equipped with a three-prong (grounding) plug for your protection against shock hazard, and must be plugged directly into a properly grounded three-prong outlet.

DO NOT cut or remove the grounding prong from this plug.

CAUTION: Label all wires prior to disconnection when servicing controls. Wiring errors can cause improper and dangerous operation. Verify proper operation after servicing.

NOTE:

- Operation of the fan increases the efficiency and the heat output of the appliance.
- The thermostat connects to the two purple wires in the harness
- Control panel light uses a 7 Watt max. bulb
- **If the unit is installed in a Mobile Home it must be connected to a grounding rod.**
- **If the unit is installed in a Mobile Home it must be bolted securely to the floor.**

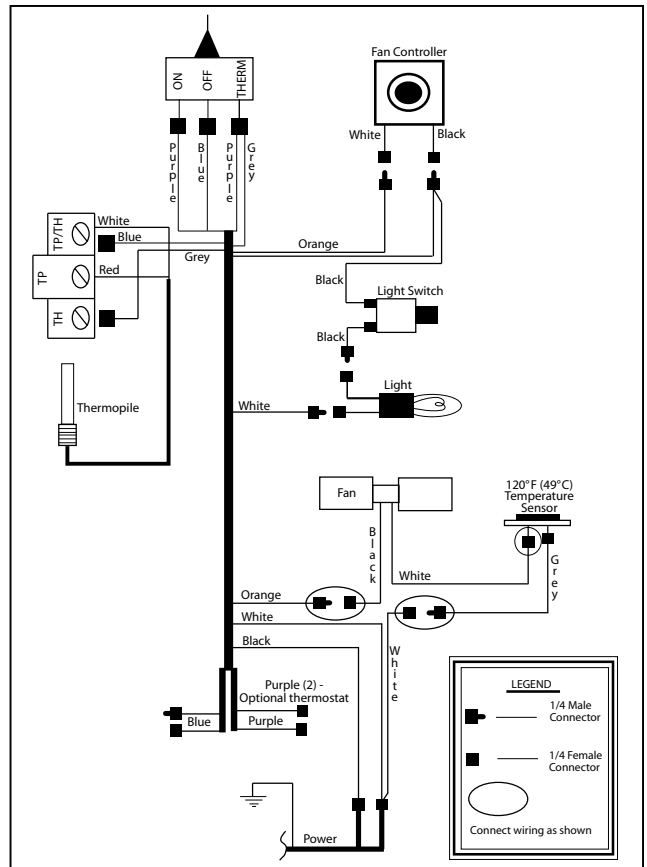

Figure 6: EG40 BV Wiring Diagram.

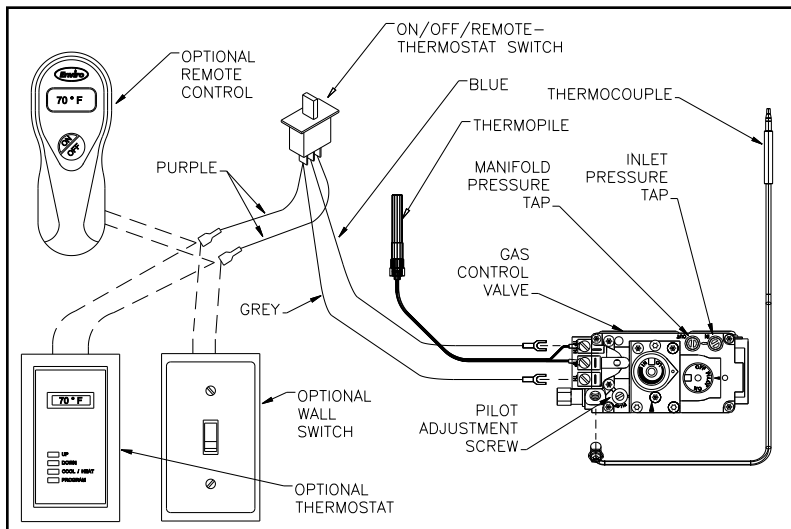

Figure 7: Wiring of a Thermostat

Table 2. Recommended Thermostat Wire Size.

Wire Size	Max. Length
14 gauge	100 ft (30.48 m)
16 gauge	60 ft (18.29 m)
18 gauge	40 ft (12.00 m)
20 gauge	25 ft (7.62 m)
22 gauge	18 ft (5.49 m)

INITIAL INSTALLATION

REPLACING THE BLOWER:

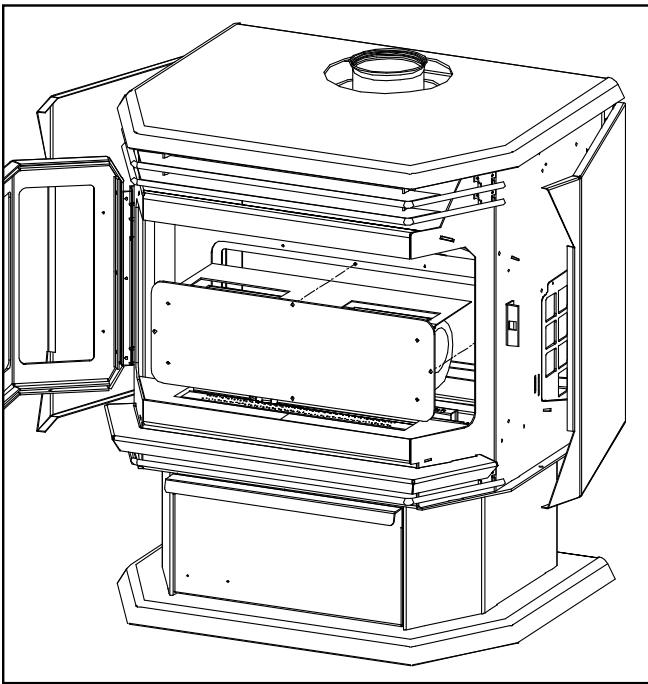

Figure 8: Blower (Fan) Removal.

1. Turn the unit off and remove the log set.
2. Remove the brick liner.
3. Remove the burner tray assembly by removing the screw on either side of the tray, between the front and rear burners. Lift the tray out.
4. Remove the four (4) $\frac{5}{16}$ " bolts that hold the blower mounting plate to the back firewall. Use a light lubricating oil on screws before removal.
5. Carefully pull the blower assembly into the firebox (see Figure 8) disconnect the blower leads from the harness and remove blower.
6. To re-install, check mounting plate gasket if damaged replace with new one and reverse steps 1 through 4. Refer to "Secondary Installation - Installation of Panel Set" and "Secondary Installation - Installation of Log Set and Embers".

ADJUSTING THE VENTURIES:

- There is a separate venturies for each burner, see Figure 9.
- Remove one screw from the cover plate located below the ash shelf and loosen the other screw (do not remove) swing the cover plate out of the way and tighten screw down to hold it in place.
- With along screwdriver rotate spring clips to open or close the venturies to the desired setting.

The venturies allows the amount of air coming into the fireplace to be adjusted in order to accommodate different climates and venting arrangements. Start the pilot and then the burner. Make sure the pilot flame is burning normally and none of the burner ports are plugged. Let the fireplace burn for roughly fifteen minutes and then examine the flames, compare the flames to Figure 16.

The ideal flame will be blue at the base and light orange above. The flames should be of medium height. If the flames look like this, no venturi adjustment is needed. If the flames are fairly short and mostly blue, the fireplace is getting too much air. Therefore, the venturies should be closed slightly until the correct flames are achieved. Flames that are very orange, with tall, dark, stringy tips, are not getting enough air. Open the venturi until the flames clean up. If the venturi is opened, or closed all the way, and the correct flames cannot be attained, turn off the gas and contact the dealer.

Warning: Incorrect venturi adjustment may lead to improper combustion, which is a safety hazard. Contact the dealer if there is any concern about the venturi adjustment.

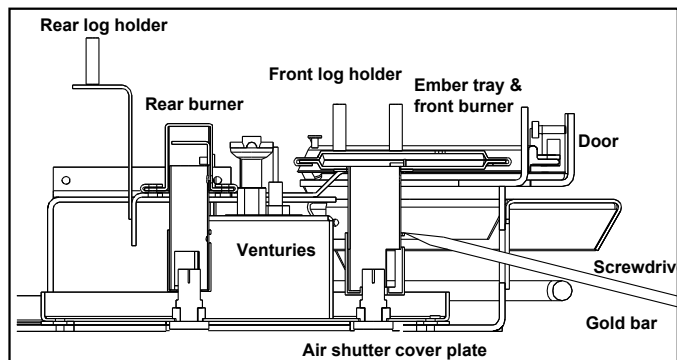

Figure 9: Venturi Adjustment.

INITIAL INSTALLATION

FUEL CONVERSION:

WARNING: This conversion kit shall be installed by a qualified service technician in accordance with the manufacturer's instructions and all applicable codes and requirements of the authority having jurisdiction. If the information in these instructions is not followed exactly, a fire, explosion or CO poisoning may result. The qualified service agency is responsible for the proper installation of this kit. The installation is not proper or complete until the operation of the converted appliance is checked as specified in the owner's conversion kit.

Please read and follow these instructions. Also please read the instruction guidelines provided by S.I.T on how to remove and install the HI-LOW regulator.

- STEP 1. Carefully inspect all parts supplied with this conversion kit.
- STEP 2. Shut the gas off and disconnect the main gas line from the unit.
- STEP 3. Open the door by unscrewing the 1/2" bolt on the right hand side of the stove. Lift door off the hinges mounted on the left-hand side.
- STEP 4. Carefully remove the log set and ember material if they are installed.
- STEP 5. Remove the two (2) T-20 screws on the burner tray located between the front and rear burners.
- STEP 6. Change the regulator on the top of the gas valve. (Follow the instructions provided by S.I.T)
- STEP 7. To change the pilot, pull the pilot hood straight up to access the pilot injector, using a 5/32" Allen key, remove the pilot injector.
- STEP 8. Install new pilot injector supplied with the conversion kit. Screw the new injector inside the pilot assembly and re-install the hood by placing the hood on the assembly, line up the keyway and snap into place
- STEP 9. Remove the two (2) main burner orifices using a 1/2" deep socket.
- STEP 10. Install the two (2) new orifices supplied making sure that the orifices are in the correct location. Be sure to put a bead of pipe thread sealant or approved Teflon tape on the orifices before installing them into the burner assembly.
- STEP 11. Re-install burner tray, log set and door. Also refer to "Installing Log Set and Embers."
- STEP 12. Reconnect the gas line to the unit. Do a leak check using soap and water solution or an approved method on the gas supply and the pilot tubing.
- STEP 13. Re-light the appliance to ensure proper operation and proper flame appearance. Be sure to adjust the venturi setting to achieve an efficient flame in the fireplace.
- STEP 14. MAKE SURE that the sticker provided by S.I.T is installed to signify that this valve has been converted to a different type of fuel. Also make sure that the rating plate has a conversion label to show that this unit has been converted to a different fuel type.

A VISUAL CHECK OF THE REGULATOR KNOB IS NECESSARY TO DETERMINE WHETHER OR NOT THE REGULATOR IS THE CORRECT PART. A 50% TURN DOWN REGULATOR WILL HAVE ONLY ONE CORNER ON THE KNOB.

- 1 - 50% turn down HI-LOW Regulator
- 3 - T-20 Torx screws
- 1 - T-20 tamper proof Torx screwdriver bit
- 1 - pilot injector
- 2 - Main orifice
- Labels to show conversion.

Table 3: Orifice Information.

	Natural Gas	Propane
Pilot Orifice	.62 mm	.35 mm
Burner Orifice Front	#48 DMS	#55 DMS
Burner Orifice Rear	#43 DMS	#54 DMS
Venturi Setting Front	1/8" min.	3/16" min.
Venturi Setting Rear	3/16" min.	1/2" Min

INITIAL INSTALLATION

GAS LINE CONNECTION AND TESTING:

WARNING: Only persons licensed to work with gas piping may make the necessary gas connections to this appliance.

GAS LINE CONNECTION

- This stove is equipped with a certified flexible pipe located on the right side of the unit terminating in a 3/8" male NPT fitting. Consult your local authorities codes or the CAN/CGA B 149 (1 or 2) installation code in Canada, or in the USA gas installations follow either local codes or the current edition of the National Fuel Gas Code ANSI Z223.1.
- The efficiency rating of this appliance is a product thermal efficiency rating determined under continuous operating conditions and was determined independently of any installed system.

The appliance and its shutoff valves must be disconnected from the gas supply piping system during any pressure testing where the pressure exceeds 1/2 PSIG (3.45 KPa) or damage will occur to the valve.

The appliance must be isolated from the gas supply piping system by closing its individual manual shutoff valve during any pressure testing of the gas supply piping system at test pressures equal to or less than 1/2 psig (3.45 KPa).

Always check for gas leaks with a soap and water solution after completing the required pressure test.

TO TEST VALVE PRESSURES

The pressure taps are located on the left side of the valve

- Turn set screw 1 turn counter clockwise to loosen,
- Place 5/16" (8 mm) I.D. hose over pressure tap system.
- Check pressures using a manometer.
- When finished, release pressure, remove hose & tighten setscrew.

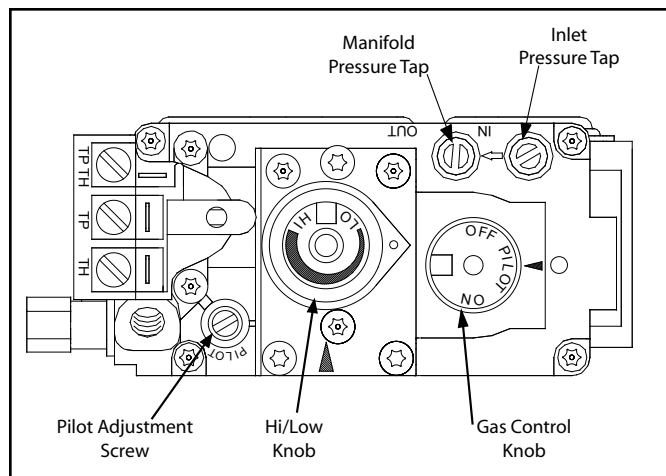

Figure 10: Fully Labeled Gas Valve.

Table 4: Pressure and BTU Information.

	Natural Gas	Propane
Front Burner	#48 DMS	#55 DMS
Rear Burner	#43 DMS	#54 DMS
Manifold Pressure	3.8" W.C. (0.95 KPa)	11.0" W.C. (2.7KPa)
Min. Manifold Pressure	1.1" W.C. (0.27KPa)	2.7" W.C. (0.67KPa)
Max Supply Pressure	7.0" W.C. (1.74KPa)	12.0" W.C. (2.98KPa)
Min. Supply Pressure	5.0" W.C. (1.24KPa)	11.5" W.C. (2.86KPa)
Max BTU/hr Input	38,000 BTU/hr (11.1KW)	38,000 BTU/hr (7.76KW)
Min. BTU/hr Input	20,000 BTU/hr (5.9 KW)	20,000 BTU/hr (5.9KW)

NEVER USE AN OPEN FLAME FOR LEAK TESTING.

SECONDARY INSTALLATION

INSTALLATION OF LOG SET AND EMBERS:

The placement of the logs is not arbitrary. If they are positioned incorrectly, the flames can be “pinched” and will not burn correctly. The burner come with five (5) locator pins, and the rear log has one (1) ledge, which make alignment easier. Using the pictures provided, carefully set the logs in place.

NOTE: The logs are fragile and should be handled gently.

CAUTION: Use only the type of ember material supplied with this appliance. Due to the irregular size of the ember material there may be more than required. The use of other foreign materials on the burners may create dangerous conditions.

If over time, through cleaning and servicing, these embers require replacement, contact the nearest ENVIRO dealer for replacement embers.



Figure 11: Step 1 of Log Placement.

1. The embers can be place before or after the logs are placed. A bag of ceramic fiber embers and rock wool embers is provided gently remove the ember material from the plastic bag. Spread a layer loosely in a random manner across the burner tray. Do not allow any embers to rest against pilot assembly. (See Figure 12 or 15 for proper ember placement.)

DO NOT pack this ember material as this could create an unsafe condition, leave embers loose

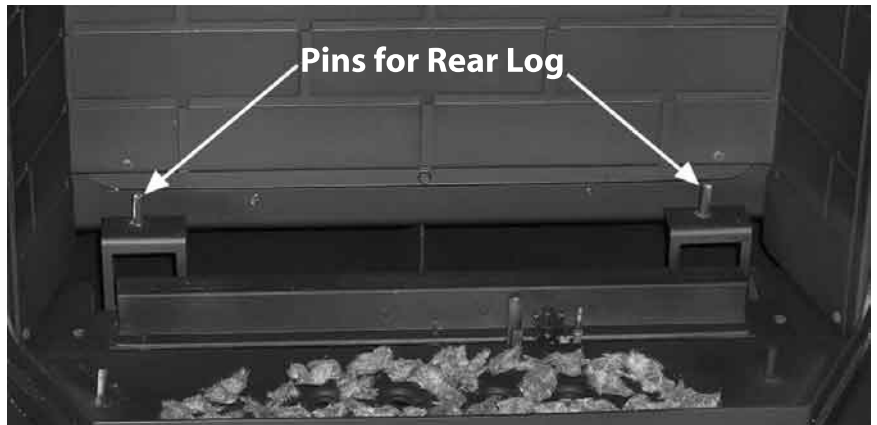

Figure 12: Step 2 of Log Placement

2. Carefully remove logs from box. Check to ensure there is no damage. It is very important to install all logs in their proper position to insure safe, optimum operating conditions.

3. Place the log set into the firebox. Locate each log by seating it down onto the burner tray support pins. Follow Figures 11 to 15 proper log placement.

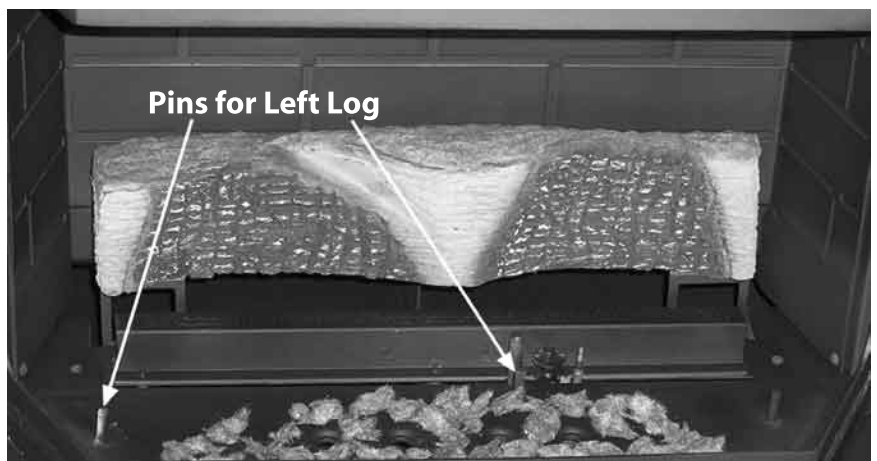

Figure 13: Step 3 of Log Placement.

SECONDARY INSTALLATION

4. Upon the first light up, watch for ignition to **ALL** burner ports. If a long delay is noted: First, wait for the appliance to cool down.

- Open the front door of the appliance.
- Check to carefully reposition the embers making sure that burner ports are not plugged solid or blocked.

Important note: When the unit is turned on for the first time, It should be turned onto high without the fan on for the first 4 hours. This will cure the paint, logs, gasket material and the other products used in the manufacturing process. It is advisable to open a window or door, as the unit will start to smoke and can irritate some people. After the unit has gone through the first burn turn the unit off including the pilot, let the unit get cold then remove the glass door and clean it with a good gas fireplace glass cleaner, available at your local ENVIRO dealer.

See Routine Maintenance And Service on how to remove door to clean glass.

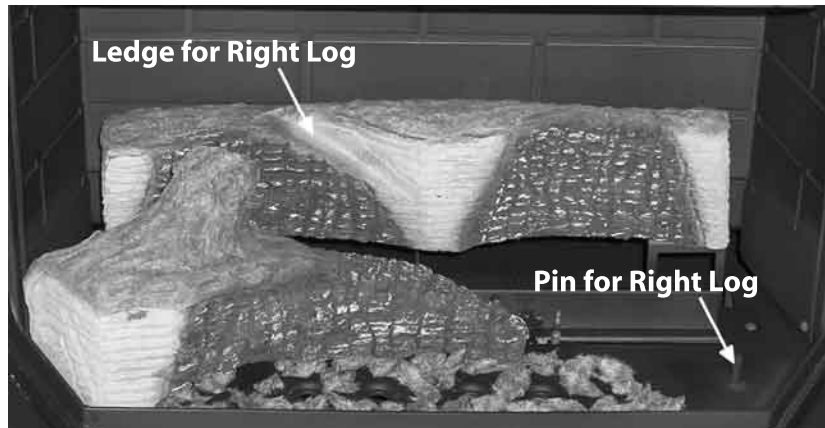

Figure 14: Step 4 of Log Placement.



Figure 15: Log Placement with Embers.



Figure 16: Appliance Burning.

CAUTION: NEVER OPERATE THIS APPLIANCE WITH THE GLASS DOOR REMOVED.

OPERATING INSTRUCTIONS

FOR YOUR SAFETY READ COMPLETELY BEFORE OPERATING.



WARNING: IF YOU DO NOT FOLLOW THESE INSTRUCTIONS EXACTLY, A FIRE OR EXPLOSION MAY RESULT CAUSING PROPERTY DAMAGE, PERSONAL INJURY OR LOSS OF LIFE.

- A) This appliance is equipped with a pilot that must be lit by hand by following these instructions exactly.
- B) BEFORE LIGHTING smell all around the appliance area for gas, and next to the floor because some gas is heavier than air and will settle on the floor.

WHAT TO DO IF YOU SMELL GAS:

- Do not try to light any appliance.
 - Do not touch any electrical switch; do not use any phone in your building.
 - Immediately call your gas supplier from a neighbor's phone. Follow the gas supplier instructions.
 - If you cannot reach your gas supplier, call the fire department.
- C) Use only your hand to push in or turn the gas control knob. Never use tools. If the knob will not push in or turn by hand, do not attempt to repair it. Call a qualified service technician. Force or attempted repair may result in a fire or explosion.
- D) Do not use this appliance if any part has been under water. Immediately call a qualified service technician to inspect the appliance and to replace any part of the control system and any gas control which has been under water.

LIGHTING INSTRUCTIONS:

1. STOP! Read the safety information above.
2. Turn off all electrical power to the appliance.
3. Turn the gas control knob clockwise  to the "off" position.
4. Open door. Wait five (5) minutes to clear out any gas. Close door. If you smell gas including near the floor, STOP! Follow "B" in the above safety information. Leak test all gas joints with soapy water **NEVER USE AN OPEN FLAME FOR LEAK TESTING**. If you don't smell gas go to next step.
5. Find the pilot located to the right between the front and rear burner.
6. Turn gas control knob counter-clockwise  to "PILOT".
7. Push the gas control knob in fully and hold. A BATTERY operated electronic igniter will light the pilot. Keep knob depressed for about 30 seconds after pilot is lit. **Check that the pilot flame has fully engulfed the thermocouple assembly (see Figure 18)**. Release knob. If pilot goes out, repeat steps 4 through 6.

WARNING: The gas valve has an lockout device which will not allow the pilot burner to be re-lit until the thermocouple has cooled.

If the knob does not pop up when released, stop and immediately call your service technician or gas supplier.

If the pilot will not stay lit after several tries, turn the gas control knob to "OFF" and call your service technician or gas supplier.

8. Turn gas control knob counter-clockwise  to the "ON" position. Flip burner switch to "ON". Turn "HI / LO" knob to the desired setting. Turn on all electrical power to the unit. Check that all burner ports have flame.
9. Leak test all gas joints again.

TURNING GAS OFF TO APPLIANCE:

1. Depress the gas control knob slightly and turn it clockwise  to "PILOT". Repeat to turn to the "OFF" position. DO NOT FORCE
2. Turn off all electrical power to the appliance if service is to be performed.
3. Flip burner switch to off, to turn off burners only.

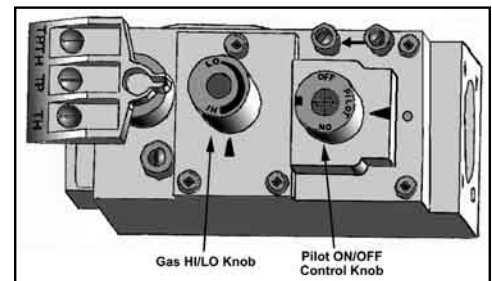

Figure 17: Gas Valve.

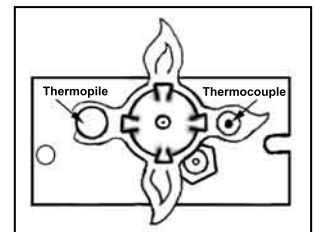

Figure 18: Pilot Burning.

ROUTINE MAINTENANCE AND SERVICE

Annually check to ensure that your Venting system is clear.

Periodically check the pilot and burner. Check to see that all the burner ports are clean and clear. Check the pilot head for blockage. Check to ensure the pilot flame is blue with no or very small yellow tips.

OPENING THE DOOR

Turn unit off and wait until the appliance has cooled down.

1. Open the right hand hinged side flap, which will expose a door fastener. Using a 1/2" wrench, loosen the fastener.
2. Due to the shape of the bay window door. You must also open the left-hand side flap before attempting to open the door.
3. If the door must be removed open the door and lift the door pins out of the hinges (see figure 19).
4. Ensure the door is properly fastened after cleaning before attempting to re-light the appliance.

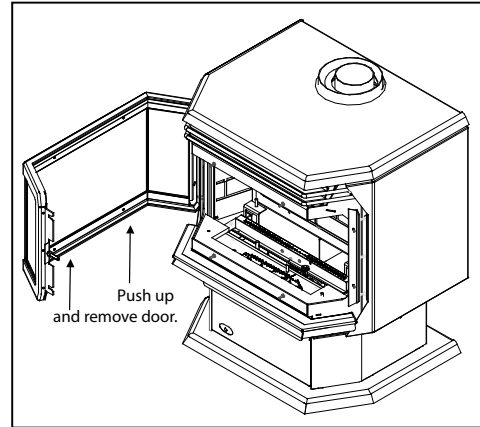

Figure 19: Removing the Door.

CLEANING THE GLASS (Allow the glass to cool before cleaning.)

It will be necessary to clean the ceramic glass periodically. During a cold start up, condensation will sometimes form on the glass. This is a normal condition with all gas fireplaces and stoves. However, this condensation can allow dust and lint to cling to the glass surface. Initial paint curing of the appliance can leave behind a slight film on the glass. This is a temporary problem. It is therefore recommended that the glass be cleaned initially after about the first four hour of use.

Depending upon the amount of use, cleaning should be required no more than two or three times per season.

To clean the door, use a mild glass cleaner and a soft cloth or a glass cleaner available from your Enviro dealer. Abrasive cleaners will damage the glass.

TO REPLACE DOOR

The glass in this appliance is an integral part of the door assembly. If the glass is damaged or broken a replacement inner door with glass assembly must be purchased.

The glass in this appliance is ceramic. If the glass is damaged or broken a factory door with glass replacement must be used.

Remove the door with glass, a new door assembly must be purchased from an ENVIRO dealer (part #: EC-063).

Do not use a substitute materials; it will void the warranty.

CLEANING THE INSIDE OF THE FIREBOX

1. Turn off the unit and allow it to cool down completely.
2. Remove the logs carefully from the firebox. Gently remove the embers and place on a piece of paper towel, until ready to replace.
3. Vacuum the bottom of the firebox thoroughly. Carefully clean off any dust on the logs and remove any lint from the main burner and pilot burner.
4. After carefully replacing the log and embers in their correct positions (see Secondary Installation - Installation of Log Set and Embers), and the door has been resealed, re-light the pilot, following the instructions on the lighting label attached to the unit.

CLEANING PLATED SURFACES:

It is important to note that fingerprints and other marks can leave a permanent stain on plated finishes. To avoid this, give the face a quick wipe with denatured alcohol on a soft cloth BEFORE lighting the fireplace. Never clean the face when it is not cool. Do not use other cleaners as they may leave a residue, which can become permanently etched into the surface.

TROUBLE SHOOTING

Problem	Possible Cause	Solution
Spark will not light the pilot after repeatedly pressing the spark ignitor	Defective piezo ignitor.	<ul style="list-style-type: none"> • Check connections to ignitor. • If ignitor connections are good but there is no spark; replace ignitor.
	Broken spark electrode.	<ul style="list-style-type: none"> • Check for broken ceramic insulation. • Replace electrode if broken.
	Misaligned spark electrode.	<ul style="list-style-type: none"> • If spark is not arcing from electrode to pilot - adjust by loosening the screws on the pilot base. Adjust away from burner and retighten.
Pilot will not remain lit	Problem with thermocouple circuit.	<ul style="list-style-type: none"> • Check for proper connection of the thermocouple to the rear of the valve. If loose, tighten lightly. • Check pilot for full flame impingement around thermocouple. If flame is too small, check gas pressure, adjust pilot rate screw, check pilot head for damage or blockage. • Check thermocouple voltage at rear of valve. It must be greater than 5 mV. If low, replace thermocouple.
	Air in gas line (pilot dies while knob is depressed).	<ul style="list-style-type: none"> • Bleed line. • Check gas line pressure. • Contact dealer.
Burners will not remain lit	Problem with thermopile circuit.	<ul style="list-style-type: none"> • Check gas line pressure . • Check for flame impingement on thermopile. If low, see "Pilot will not remain lit". • Check thermopile for minimum of 200 mV when burner is switched on. • Check wiring to thermostat for breaks.
Flame lifting	Leak in vent pipe.	<ul style="list-style-type: none"> • Check for leaks in vent connections.
	Improper vent configuration.	<ul style="list-style-type: none"> • Check vent configuration with manual.
	Terminal may be recirculating flue gases.	<ul style="list-style-type: none"> • Check to see if the terminal is on correctly. • May need to install high wind termination cap. • Contact dealer.
Glass fogs up	Normal Condition: after the appliance warms up the glass will clear. **Due to additives in gas, glass may get hazy during operation** Clean as needed.	
Blue Flames	Normal during start up: flames will yellow as the fireplace heats up.	
Flames are burning "dirty" or sooting	Flame impingement	<ul style="list-style-type: none"> • Check log positioning. • See also "Burners will not remain lit."
Flame goes out / comes on frequently during a short period of time.	Defective rocker switch.	<ul style="list-style-type: none"> • Check rocker switch connections. • Replace switch if necessary.

PARTS LIST

Reference Number	Part Description	Part Number
1	120 °F (49 °C) Ceramic Temperature Sensor	EC-001
2	220 °F (104 °C) Ceramic Spill Switch	EC-002
3	S.I.T. NOVA Valve NG (50% turn down)	EC-006
3	S.I.T. NOVA Valve LP (50% turn down)	EC-007
4	Thermocouple	EC-009
4	Spark Electrode with Ignitor Cable	EC-011
4	Thermopile	EC-012
4	Fully Assembled Pilot NG	EC-015
4	Fully Assembled Pilot LP	EC-016
4	Pilot Orifice NG Threaded	EC-019
4	Pilot Orifice LP Threaded	EC-020
	Pilot Gasket	EC-021
5	S.I.T. Piezo Ignitor	EC-023
	Stainless Steel Flex Connector with 3/8" Elbow 18" Long	EC-024
6	Burner Switch	EC-025
7	Miniature Light Bulb (115V)	EC-031
7	Light Bulb Holder	EC-032
	Wiring Harness Complete (2 pieces)	EC-037
	Body Wiring Harness	EC-037A
	Burner Wiring Harness	EC-037B
	Fan Control Knob	EC-040
	IEC Power Cord - 115V	EC-043
	4 oz. Bag Coal Embers Only	EC-045
8	1" x 1" Side Cabinet Hinge	EC-054
	Pedestal Door Magnet	EC-056
	3/8" Tadpole Door Gasket (7 ft)	EC-057
	Window Channel Tape 72"	EC-058
9	Door Latch Bolt	EC-059
10	Inner Door with glass	EC-063
11	Light Switch	EC-066
12	Fan Controller with Knob - 115V	EF-045
	Latch Bracket & Nut	EG40-023
13	Convection Air Deflector	EG40-033
	Side Panel Magnet	EG40-049
	Fan Access Cover Gasket	EG40-066

PARTS LIST

Reference Number	Part Description	Part Number
	BV Owner's Manual	EG40-071
14	Pedestal	EG40-080
15	Side Panel	EG40-086
16	BV Stove Top	EG40-087
	Firebox Baffle	EG40-088
	Stove Top Baffle BV	EG40-091
	Venturi Cover Plate	EG40-097
17	Front Venturi	EG40-098
18	Bar Set - Painted (3 pieces)	EG40-114
18	Bar Set - Gold (3 pieces)	EG40-115
18	Bar Set - Nickel (3 pieces)	50-478
	Burner Gasket	EG40-120
	Steel Brick Liner	EG40-129
	Brick Liner Backing	EG40-130
19	Pedestal Door	EG40-135
	LP to NG Conversion Kit	EG40-200
	NG to LP Conversion Kit	EG40-202
20	Ash Sill	EG40-213
21	Door Hinge (Set of 2)	EG40-302
22	Fan Mount	EG40-304
23	Pedestal Box Cover	EG40-307
24	Burner Control Assembly NG	30-014
24	Burner Control Assembly LP	30-015
25	Front Pan Burner	30-016
26	Rear Burner with Venturi	30-017
	Pilot 1/8" Tube with Ferules	30-043
	Log Set Complete	50-081
27	Blank Orifice #73	50-343
28	Door Cover - Gold	50-480
28	Door Cover - Painted	50-776
28	Door Cover - Brushed Nickel	50-1063
29	Convection Blower - 115V	50-514
	16" Ignitor Wire	50-652
	IEC Power Cord Inlet Socket	50-713
	Burner Tray Top NG & LP	50-774

PARTS DIAGRAM - CHASSIS

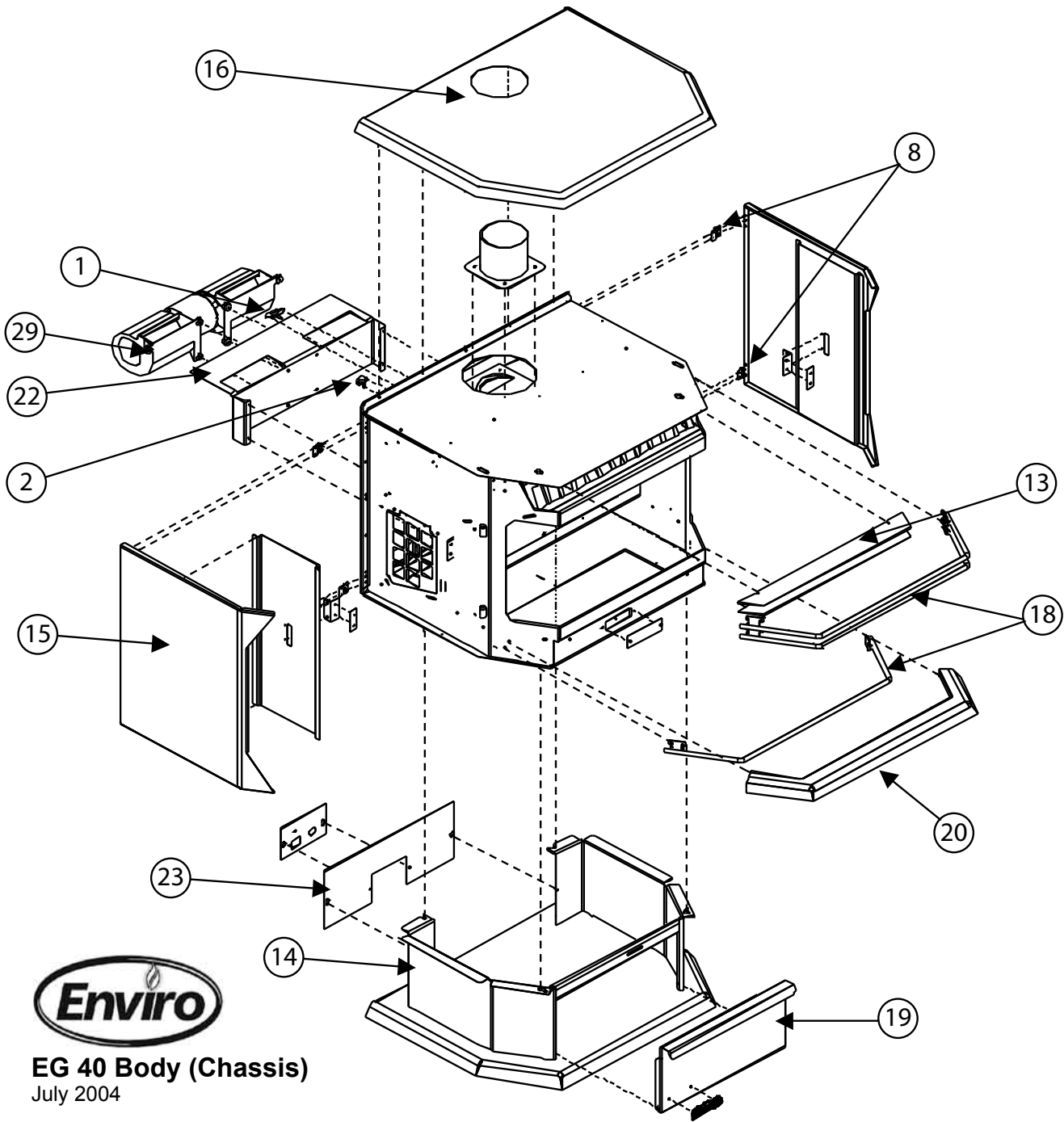

EG 40 Body (Chassis)
July 2004

PARTS DIAGRAM - GAS TRAY & DOOR



EG40 Gas Tray & Door Assemblies
July 2004

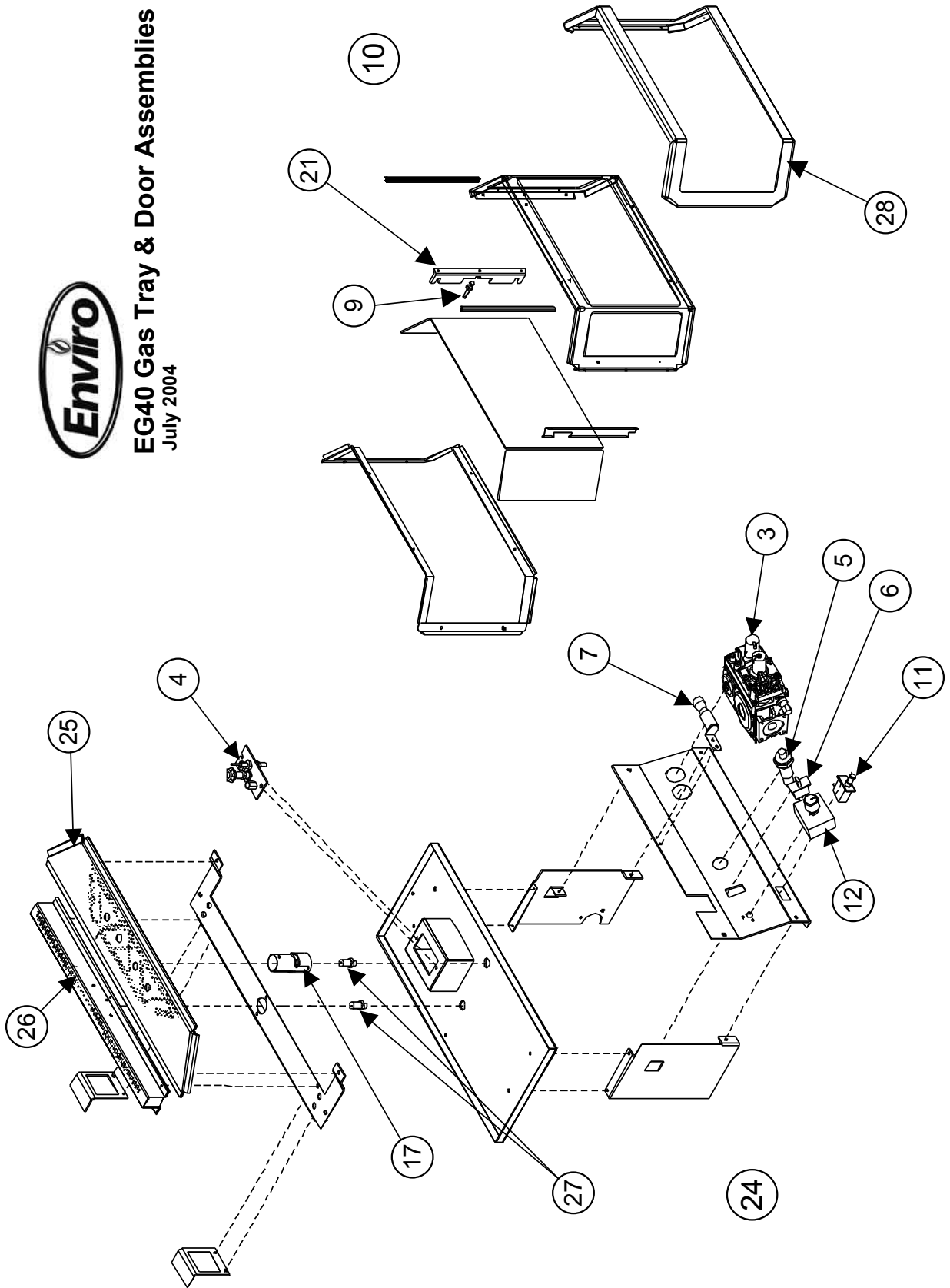

WARRANTY

Sherwood Industries Ltd. offers a Limited Lifetime Warranty on this gas product. This limited lifetime warranty covers the appliance for a period of seven years from the date of installation. This warranty applies only to the original owner in the original location

Covered under the lifetime warranty are Cabinet Sides, Tops, Pedestals, Surround Panels and Chassis and Heat Exchanger. These steel components are covered against manufacturer's defects for 5 years and labor for the first year and for parts only thereafter.* The following exclusions apply:- over-firing due to incorrect setup or tampering, damage caused by incorrect installation, usage or abuse. The unit must be properly installed by a qualified technician or installer, and must meet all local and national gas and building code requirements.

We also cover against manufacture defects under our lifetime warranty. The following components, Gold Plating, Log Set, Burners and Glass (*) The following exclusions apply:

Gold plating- Damage caused by scratching, marring, chemicals, fingerprints, abrasive cleaners or discoloration with age or over-firing

Glass- use of harsh or abrasive cleaners, striking the glass or surface contaminates.

Log-set- Damage caused by incorrect handling or misuse.

Burners- damage caused by improper or continuous operation under incorrect conditions.

The paint on the Metal Brick Liner may peel. This is due to the extreme conditions applied to the paint and is no way covered under warranty.

* TO A MAXIMUM OF SEVEN YEARS

Sherwood Industries Ltd. offers a 2-year warranty on all the Electrical Components and Gas Components against manufacturing defects. Paint is covered against flaking. This offer includes parts and labor for 1 year and for parts only thereafter.

Your dealer shall make all claims under this warranty in writing.

WHEN FILING A WARRANTY CLAIM PLEASE COMPLETE THE FOLLOWING INFORMATION ON AN OFFICIAL WARRANTY CLAIM FORM:

TO THE DEALER

Name, address and telephone number of purchaser and date of purchase.

Date of installation. Name of installer and dealer. Serial number of the appliance. Nature of complaint, defects or malfunction, description and part numbers of any parts replaced.

TO THE DISTRIBUTOR

Sign and verify that work and information are correct.

This warranty covers defects in materials and workmanship only if the product has been installed according to the manual's instructions. If the product is damaged or broken as a result of misuse or mishandling the warranty does not apply. The warranty does not cover removal and re-installation costs.

Sherwood Industries Ltd. reserves the right to repair or to replace the defective product. The shipping costs are to be paid by the consumer. All warranties by the manufacture are set forth herein and no claim shall be made against the manufacturer on any oral warranty or representation.

Sherwood Industries Ltd. and its employees or representatives will not assume any damages, either directly or indirectly caused by improper usage, operation, installation, servicing or maintenance of this appliance.

Sherwood Industries Ltd. reserves the right to make changes without notice. Please complete and mail the warranty registration card and have the installer fill in the installation data sheet in the back of the manual for warranty and future reference.

INSTALLATION DATA SHEET

The following information must be recorded by the installer for warranty purposes and future reference.

NAME OF OWNER: _____

ADDRESS: _____

PHONE: _____

NAME OF DEALER: _____

ADDRESS: _____

PHONE: _____

MODEL: _____

SERIAL NUMBER: _____

DATE OF PURCHASE: _____ (dd/mm/yyyy)

DATE OF INSTALLATION: _____ (dd/mm/yyyy)

NATURAL GAS (NAT) PROPANE(LPG)

INLET GAS PRESSURE: _____ in wc

MAIN BURNER ORIFICE: _____ # DMS

PILOT ORIFICE # _____ OR _____ in diam.

INSTALLER'S SIGNATURE: _____

NAME OF INSTALLER: _____

ADDRESS: _____

PHONE: _____

MANUFACTURED BY:
SHERWOOD INDUSTRIES LTD.
6782 OLDFIELD RD. SAANICHTON, BC, CANADA V8M 2A3
www.envirofire.biz
February 21, 2005
C-10366