

BATTERY OPERATED BI-PLANE

Model 91311

ASSEMBLY & OPERATING INSTRUCTIONS

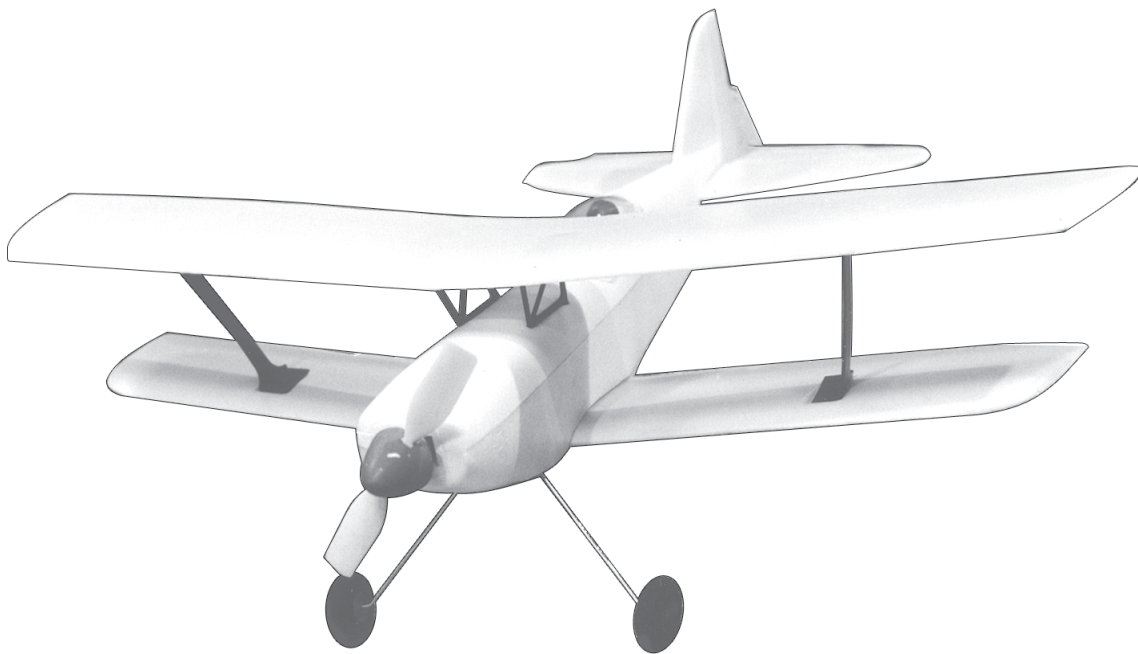

3491 Mission Oaks Blvd., Camarillo, CA 93011

Visit our Website at www.harborfreight.com

IMPORTANT:

If damage is caused due to a crash, your warranty is void.

Copyright© 2004 by Harbor Freight Tools®. All rights reserved. No portion of this manual or any artwork contained herein may be reproduced in any shape or form without the express written consent of Harbor Freight Tools.

For technical questions and replacement parts please call 1-800-444-3353.

REV 10/05

THANK YOU for choosing a **HARBOR FREIGHT TOOLS** product. For future reference, please complete the owner's record below:

Model _____ **Serial No.** _____ **Purchase Date** _____

SAVE THE RECEIPT, WARRANTY AND THESE INSTRUCTIONS. It is important that you read the entire manual to become familiar with the unit BEFORE you begin assembly.

Technical Specifications

Upper Wing Span: 15-7/8" L x 2-1/2" W
Bottom Wing Span: 14-3/8" L x 2-5/8" W
Fuselage: 12-3/8" L x 1-5/8" W x 3" H
Horizontal Tail: 6-3/4" L x 2-5/8" W
Tail Height: 3-1/4" H x 2-3/4" W
Also included: (1) spare propeller, (1) battery charger and glue.

The Bi-Plane charger requires 4 "AA" size batteries. Not included.



READ ALL INSTRUCTIONS BEFORE USING THIS PRODUCT!

Safety Warnings and Precautions

WARNING: When using product, basic safety precautions should always be followed to reduce the risk of personal injury and damage to equipment.

Read all instructions before using this product!

1. **Keep work area clean.** Cluttered areas invite injuries.
2. **Observe work area conditions.** Keep work area well lit. Keep work area uncluttered and free of debris. Cluttered areas invite injury.
3. **Check for damaged parts.** Before using any product, any part that appears damaged should be carefully checked to determine that it will operate properly and perform its intended function. Check for any broken or damaged parts and any other conditions that may affect its operation. Replace or repair damaged or worn parts immediately.
4. **Replacement parts and accessories.** When servicing, use only identical replacement parts. Use of any other parts will void the warranty.
5. **Always check hardware and assembled parts after assembling.** All connections should be tight and hardware tightened.
6. **Children should only be allowed to play with the Bi-Plane when closely supervised by a responsible adult.**
7. **Store idle equipment.** When not in use always lock up the Bi-Plane and keep it out of the reach of children.
8. **Dress properly.** Wear restrictive hair covering to contain long hair.
9. **Use eye protection.** Always wear ANSI approved impact safety goggles when assembling this product.
10. **Maintain products with care.** Keep the Bi-Plane in a dry location. Do not expose it to prolonged moisture.

11. **Do not modify this Bi-Plane and do not use this Bi-Plane for a purpose for which it was not intended.**
12. **Do not use or assemble the Bi-Plane if under the influence of alcohol or drugs.** Read warning labels on prescriptions to determine if your judgement or reflexes are impaired while taking drugs. If there is any doubt, do not assemble or use the Bi-Plane.
13. **Do not pick up the Bi-Plane while it is in motion.**
14. **Use only Batteries of the type recommended.**
15. **Do not mix old and new batteries.**
16. **Remove batteries if the Bi-Plane is not used for a long period of time.**
17. **Do not recharge non-rechargeable batteries.**
18. **Make certain to use the Bi-Plane in a large area free from interference from trees, electrical power lines and other obstacles.**
19. **Never fly near buildings, cars or busy streets.**
20. **Do not fly the Bi-Plane at or near other people or animals.**
21. **Do not fly the Bi-Plane if wind speeds are above 10 MPH.**
22. **Do not allow children to use glue without adult supervision.** Make certain that the glue is stored out of reach of children and animals.

WARNING: The warnings, cautions, and instructions discussed in this instruction manual cannot cover all possible conditions and situations that may occur. It must be understood by the operator that common sense and caution are factors which cannot be built into this product, but must be supplied by the operator.

Assembly/ Operation

Your Battery Operated Bi-Plane will require complete assembly. It is important that you read the entire manual to become familiar with the product BEFORE you use the Bi-Plane. Before assembling the Bi-Plane be sure that you have all parts described in the Parts List and Assembly Diagram located on the last pages of this manual.

Set out all parts on a clear and level surface prior to assembly.

1. Insert the Battery/Switch Compartment Plug (13) into the plug located on the Fuselage (1)- see Figure 1.
2. Remove the backing from the tape on the center of the Lower Wing (11).

IMPORTANT:
If damage is caused due to a crash, your warranty is void.

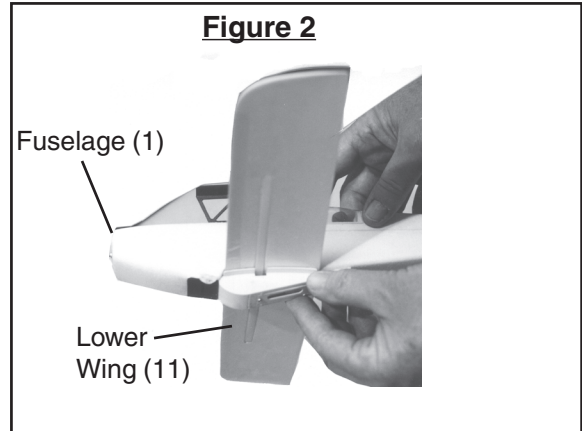
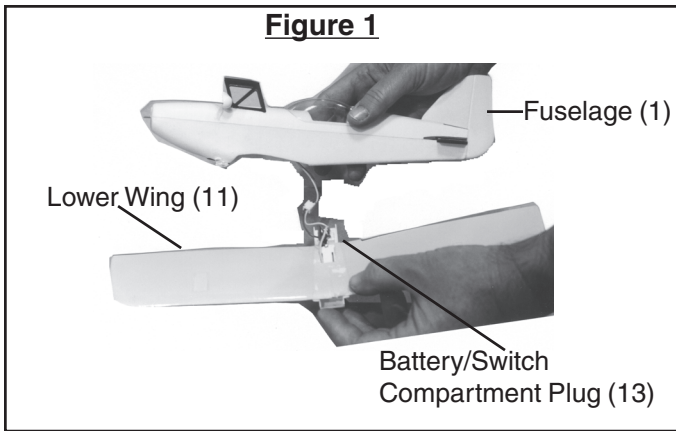

Note: Make certain to only peel off the backing. Peeling off too much will also remove the sticky tape so that the parts will not adhere to one another. The backing should peel off easily; if it is not coming off easily, you may be removing the backing and the tape.

3. Attach the Lower Wing (11) with Battery/Switch Compartment Plug (13) to the Fuselage-see Figure 2. Make certain that the Lower Wing (11) with Battery/Switch Compartment Plug (13) and the Fuselage (1) are lined up perfectly before pressing them together.
4. Locate both Bi-Wing Supports (10). The Bi-Wing Supports (10) must be set on the Lower Wing (11) pointing forward and outward-see Figure 3. Remove the tape backing from both sides of the Lower Wing (11) and press the Bi-Wing Supports (10) into place as in Figure 3.

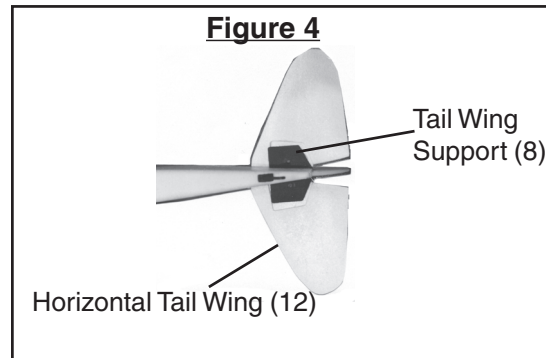
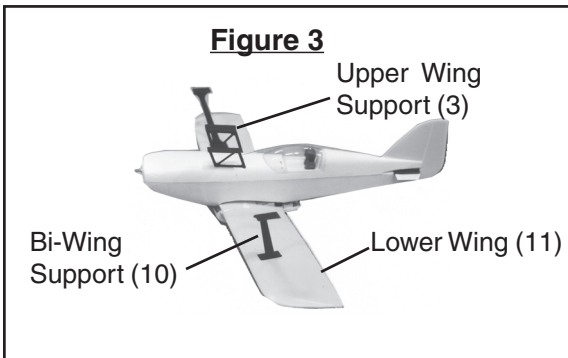

5. Remove the four tape backings from under the Upper Wing (9). Line up the taped areas with the Upper Wing Supports (3) and the Bi-Wing Supports (10). Press the Upper Wing (9) into place.
6. Locate the two (2) Horizontal Tail Wings (12). Remove the tape backings from the Tail Wing Platform. Line up the taped areas of the Horizontal Tail Wings (12) with the Tail Wing Support (8) and press them into place-see Figure 4.
7. Snap the Landing Gear Assembly (15) into the slot at the front and bottom of the Fuselage (1)- see Figure 5.
8. With one hand holding the Fuselage (1), push the Propeller (16) and Spinner (17) onto the shaft located on the nose of the Fuselage (1).
9. Place the Decals (19) on the Bi-Plane.

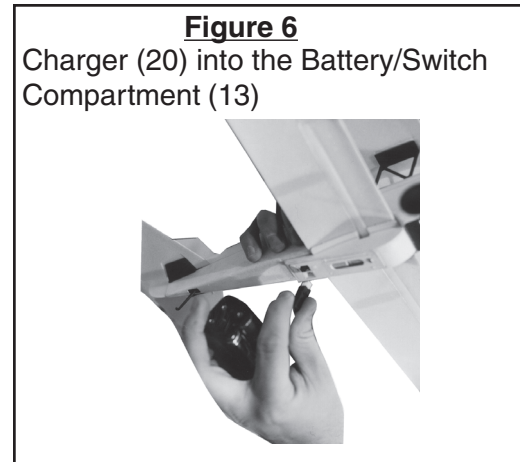
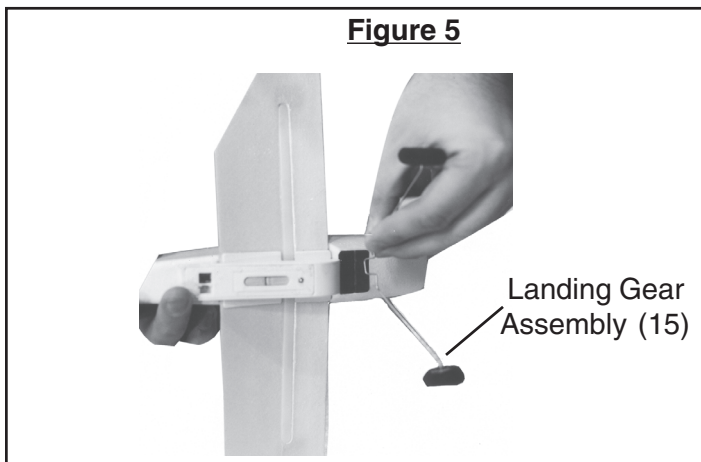

10. Make certain that the “On/OFF” switch for the Bi-Plane is in the “OFF” position. Install four (4) “AA” Batteries into the Charger (20) making certain that the (+) and (-) polarity marks are lined up correctly.
11. Plug the Charger (20) into the Battery/Switch Compartment (13)- see Figure 6. Charge the Batteries for 30 seconds only.
WARNING! NEVER charge the batteries longer than 30 seconds. Overcharging can cause overheating, resulting in PERSONAL INJURY or property damage.
 Turn the Bi-Plane “ON” and allow the batteries to run through one cycle until the Bi-Plane runs down. Recharge battery at this point.

First Motorized Test Flight

Fly the Bi-Plane in an open area, free of obstructions (especially phone and electrical power lines) and fly it on a calm day. **Never fly in winds above 10 MPH.**

Make certain that you fly in a large and clear area as you experiment with flight patterns. Wind can take the Bi-Plane a considerable distance.

Flying the Bi-Plane

1. Turn the On/Off Switch on the Bi-Plane to the “ON” position. Tilt the Bi-plane with the nose 10 degrees upward and face it into the wind. Firmly toss the Bi-Plane.
2. Turning “OFF” the power for about 15 minutes between each flight will prolong your batteries life-span.
3. To adjust the flight radius of the Bi-Plane, you can bend the rudder of the Horizontal Tail Wing (12) two or three degrees left or right.
4. Check the Bi-Plane for damage before each use. Make certain that the wings are correctly aligned and that they are free from damage. Make certain that the Bi-Plane and all of its parts are free from damage. Make certain that the Propeller (16) is securely in place before using.
5. The Bi-Plane comes with one container of Glue for any minor repairs which are needed if damage occurs during use.

Unpacking

When unpacking the Battery Operated Bi-Plane, check to make sure the following parts are included. If any parts are missing or broken, please call **HARBOR FREIGHT TOOLS** at **1-800-444-3353**.

Part #	Description	Quantity	Part #	Description	Quantity
1	Fuselage	1	11	Low wing	1
2	Motor Mount	1	12	Horizontal Tail Wing	2
3	Upper Wing Support	2	13	Battery-Switch Compartment	1
4	Canopy	1	15	Landing Gear Assy	1
5	Pilot	1	16	Propeller	1
6	Vertical Tail Wing	1	17	Spinner	1
7	Horizontal Tail Wing	1	18	Motor	1
8	Tail Support	1	19	Decals	2
9	Upper Wing	1	20	Charger	1
10	Bi-wing Support	2			

Note: Some parts are listed and shown for illustration purposes only and are not available individually as replacement parts.

PLEASE READ THE FOLLOWING CAREFULLY

THE MANUFACTURER AND/OR DISTRIBUTOR HAS PROVIDED THE PARTS DIAGRAM IN THIS MANUAL AS A REFERENCE TOOL ONLY. NEITHER THE MANUFACTURER NOR DISTRIBUTOR MAKES ANY REPRESENTATION OR WARRANTY OF ANY KIND TO THE BUYER THAT HE OR SHE IS QUALIFIED TO MAKE ANY REPAIRS TO THE PRODUCT OR THAT HE OR SHE IS QUALIFIED TO REPLACE ANY PARTS OF THE PRODUCT. IN FACT, THE MANUFACTURER AND/OR DISTRIBUTOR EXPRESSLY STATES THAT ALL REPAIRS AND PARTS REPLACEMENTS SHOULD BE UNDERTAKEN BY CERTIFIED AND LICENSED TECHNICIANS AND NOT BY THE BUYER. THE BUYER ASSUMES ALL RISK AND LIABILITY ARISING OUT OF HIS OR HER REPAIRS TO THE ORIGINAL PRODUCT OR REPLACEMENT PARTS THERETO, OR ARISING OUT OF HIS OR HER INSTALLATION OF REPLACEMENT PARTS THERETO.

