

# *Panther*™

*panthercarts.com*

## **FOLDING SIDES GARDEN WAGON**

**MODEL H0771**

## **INSTRUCTION SHEET**



COPYRIGHT © MARCH, 2004 BY GRIZZLY INDUSTRIAL, INC.  
**WARNING: NO PORTION OF THIS MANUAL MAY BE REPRODUCED IN ANY SHAPE  
OR FORM WITHOUT THE WRITTEN APPROVAL OF GRIZZLY INDUSTRIAL, INC.**  
#6143 PRINTED IN CHINA

# PARTS INVENTORY

After removing the wagon from the box, you should find the following components:

**Figure 1 - Main Contents.**

A.	Front Panel.....	1
B.	Back Panel.....	1
C.	Pull Handle.....	1
D.	Wheels.....	4
E.	Left Rear Axle Brace.....	1
F.	Right Rear Axle Brace.....	1
G.	Center Front Axle Brace.....	1
H.	Bolt Bag.....	1
I.	Steering Connector.....	1
J.	Plastic Coupling.....	1
K.	Yoke.....	1
L.	Front Axle Support.....	1
M.	Rear Axle Support.....	1
N.	Bed.....	1
O.	Side Panels.....	2
P.	Tractor Connector.....	1

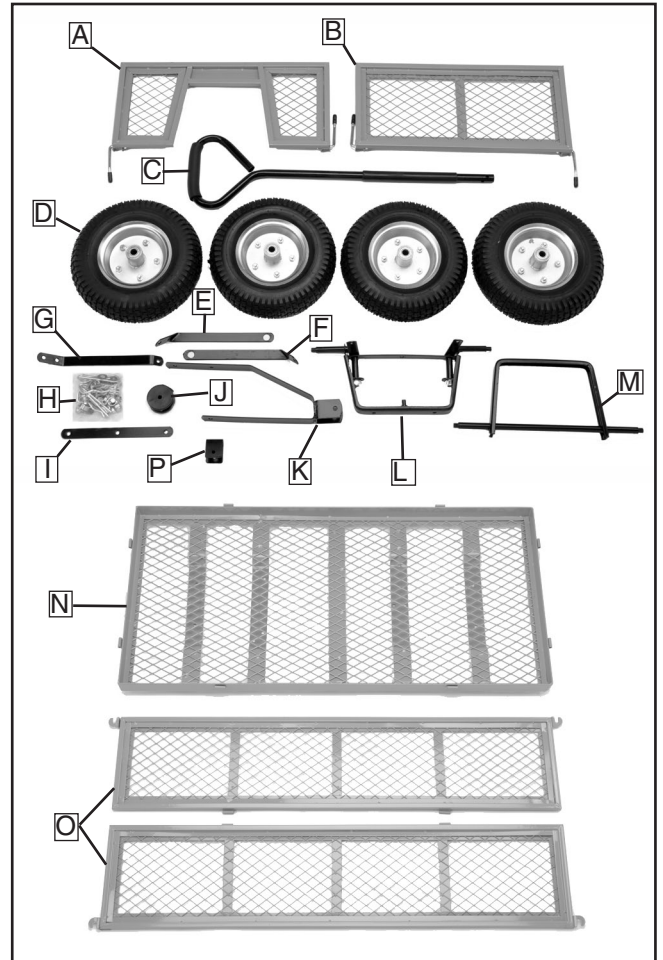

**Figure 1.** Main contents.

**Figure 2 - Bolt Bag.**

—	Panel Assembly Pins.....	8
—	Flat Washer 8mm.....	11
—	Lock Nut M8-1.25.....	11
—	Wheel Bushing.....	4
—	Acorn Nut M12-1.75.....	4
—	Lock Washer 12mm.....	4
—	Flat Washer 12mm.....	4
—	Carriage Bolt M8-1.25 x 20.....	10
—	Slotted Screw M8-1.25 x 80.....	1
—	Shoulder Bolt M8-1.25 x 15.....	3
—	Shoulder Bolt M8-1.25 x 17.....	1
—	Flat Washer 6mm.....	4
—	Lock Nut M6-1.0.....	4
—	Flat Washer M10.....	1
—	Cotter Pin.....	1

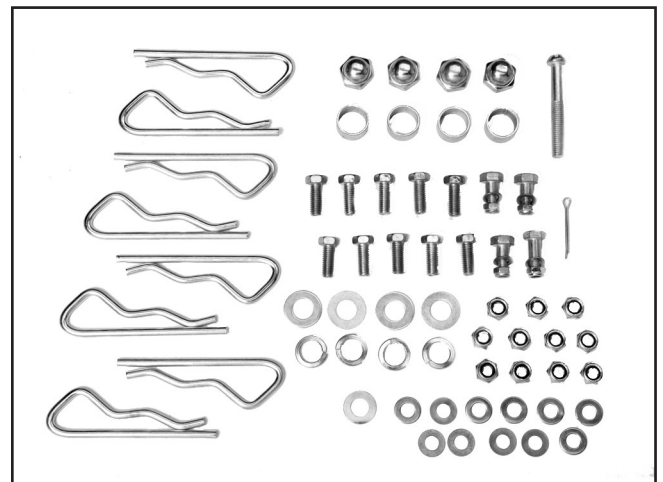

**Figure 2.** Bolt bag contents.

## CAUTION

Adult supervision is always required while this wagon is being used by children.

# ASSEMBLY INSTRUCTIONS

## REMOVAL & INVENTORY

1. Remove your new wagon from the carton.
2. Make sure all parts are present and in good condition.

## FRONT SUPPORT ASSEMBLY

1. Insert the yoke into the front axle support by sliding the top hole of the yoke onto the pivot post on the front axle support. Place the 10mm flat washer on the pivot post and slide the cotter pin in the pre drilled hole and spread. Bolt the center front axle brace and yoke to the bottom of the front axle support with the M8-1.25 x 17 shoulder bolt, 6mm flat washer and lock nut. See **Figure 1**

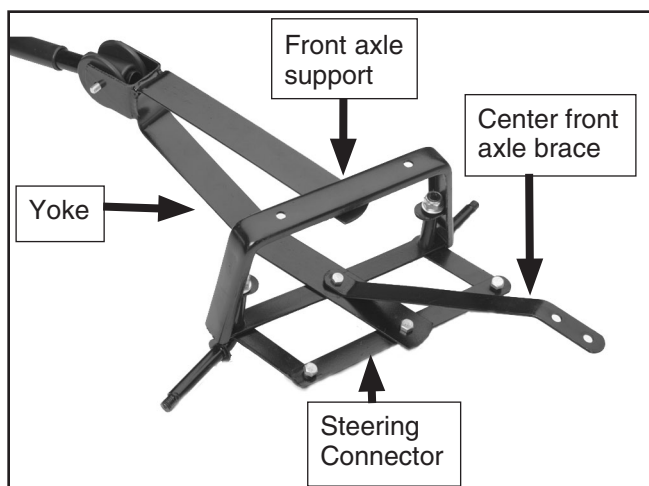
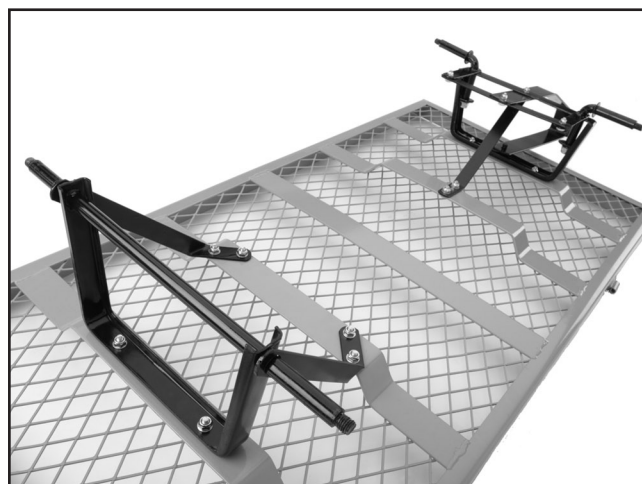

**Figure 1.** Front axle assembly detail.

2. Bolt the steering connector to the steering arms of the front axle support and the yoke using M8-1.25 x 15 shoulder bolts, 6mm flat washers and lock nuts.
3. Mount the front axle assembly to the end of the bed with the corresponding bolt pattern using M8-1.25 x 20 carriage bolts, 8mm washers and lock nuts.

## REAR SUPPORT ASSEMBLY & WHEELS

1. Loosely assemble the rear axle support to the bed using M8-1.25 x 20 carriage bolts, 8mm washers and lock nuts.
2. Slide the left and right rear axle braces onto the rear axles and bolt the opposite ends of the braces to the bed using M8-1.25 x 20 carriage bolts, 8mm washers and lock nuts. See **Figure 2**
3. Tighten the rear axle support.



**Figure 2.** Rear and front axle assemblies

4. Slide a wheel spacer bushing, part 22, on each axle.
5. Slide a wheel onto each axle with the valve stems to the outside and fasten using the M12-1.75 acorn nuts, 12mm flat washers and lock washers.

## FOLDING SIDES

1. Using the panel assembly pins, fasten the hinges of the side panels to the bed, with the side panel hinges on the outside.
2. Fasten the hinges of the front panel to the end with the front axle assembly using the panel assembly pins.
3. Fasten the hinges of the back panel to the end with the rear axle support using the panel assembly pins.

## PULL HANDLE

1. Slide the plastic coupling on to the pull handle, making sure the holes are correctly aligned.
2. Place the pull handle and plastic coupling into the yoke and insert the M8-1.25 x 80 slotted screw. Fasten using an 8mm washer and lock nut.

*Note—The Folding Sides Garden Wagon comes equipped with a tractor connector. Slide the tractor connector over the handle of the wagon and connect to the tractor hitch.*

*If you need additional help with this procedure, call our service department at: (570) 546-9663.*

# H0771 Parts Breakdown and List

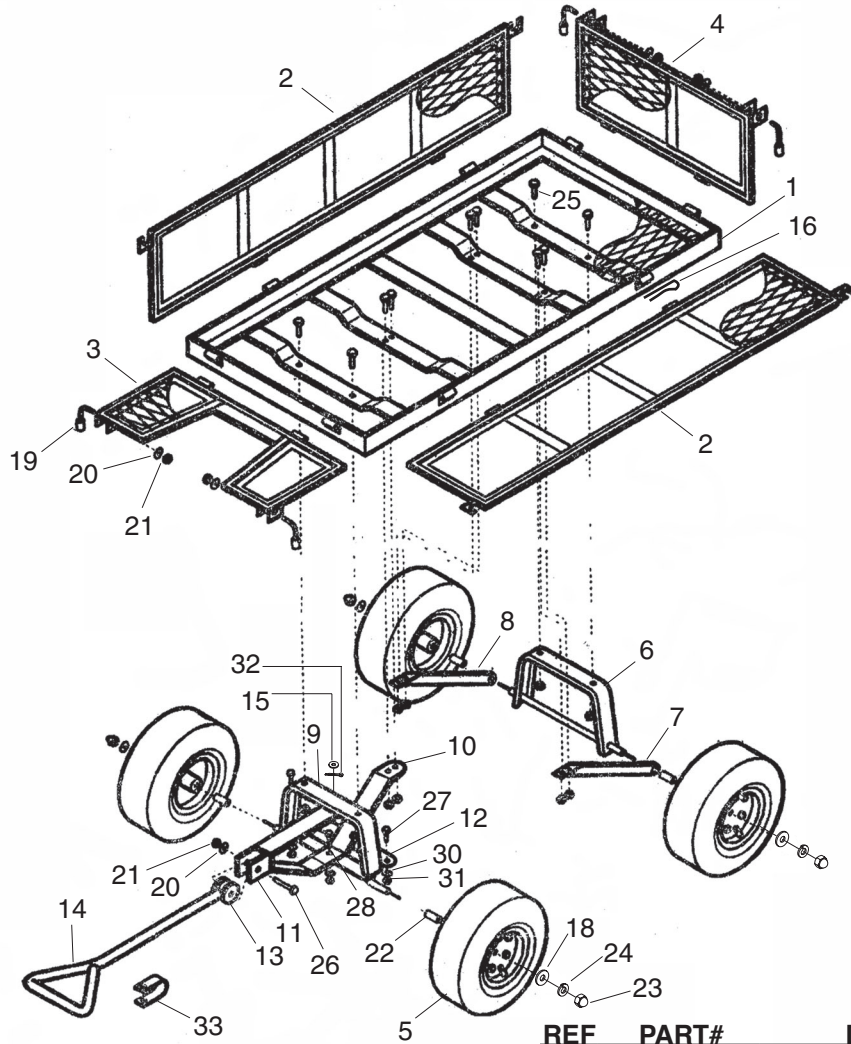

REF	PART#	DESCRIPTION
1	PH0771001	BED PANEL
2	PH0771002	SIDE PANEL
3	PH0771003	FRONT PANEL
4	PH0771004	BACK PANEL
5	PH0771005	WHEEL 13" X 5.00-6
6	PH0771006	REAR AXLE SUPPORT
7	PH0771007	LEFT REAR AXLE BRACE
8	PH0771008	RIGHT REAR AXLE BRACE
9	PH0771009	FRONT AXLE SUPPORT
10	PH0771010	CNTR FRONT AXLE BRACE
11	PH0771011	YOKE
12	PH0771012	STEERING CONNECTOR
13	PH0771013	PLASTIC COUPLING
14	PH0771014	PULL HANDLE
14-1	PH0771014-1	PAD (LOWER)
14-2	PH0771014-2	PAD (UPPER)

REF	PART#	DESCRIPTION
15	PW04M	FLAT WASHER 10MM
16	PH0771016	PANEL ASSEMBLY PINS
18	PW06M	FLAT WASHER 12MM
19	PH0771019	MALE LOCK HANDLE M8-1.25
20	PW01M	FLAT WASHER 8MM
21	PLN04M	LOCK NUT M8-1.25
22	PH0771022	WHEEL SPACER BUSHING
23	PN26M	ACORN NUT M12-1.75
24	PLW05M	LOCK WASHER 12MM
25	PCB01M	CARRIAGE BOLT M8-1.25 x 20
26	PH0771026	SLOT SCREW M8-1.25 x 80
27	PH0771027	SHLDR BOLT M8-1.25 x 15
28	PH0771028	SHLDR BOLT M8-1.25 x 17
30	PW03M	FLAT WASHER 6MM
31	PLN03M	LOCK NUT M6-1.0
32	PH0771032	COTTER PIN
33	PH0771033	TRACTOR CONNECTOR