

11. WARRANTY

Royal Sovereign International warrants the equipment sold is free from defects in material and workmanship for a period of One (1) year for Parts and Labor from the date of installation, excluding lamination rollers which are warranted for Six (6) months. This warranty is extended only to the original purchaser. This warranty is the only warranty made by Royal Sovereign International and cannot be modified or amended. Royal Sovereign's sole and exclusive liability and the customer's sole and exclusive remedy under this warranty shall be, at Royal Sovereign's option, to repair or replace any such defective part or product. These remedies are only available if Royal Sovereign's examination of the product discloses to Royal Sovereign's satisfaction that such defects actually exist and were not caused by misuse, neglect, attempt to repair, unauthorized alternation or modification, incorrect line voltage, fire, accident, flood or other hazard.

The warranty made herein is in lieu of all other warranties, expressed or implied, including any warranty or merchantability or fitness for a particular purpose. Royal Sovereign will not be liable for personal damage or personal injury (unless primarily caused by its negligence), loss of profit, or other incidental or consequential damages arising out of the use or inability to use this equipment.

LIMITED WARRANTY

This warranty specifically does not cover damage to laminating rollers caused by knives, razor blades, or any sharp objects or abrasives, or failure caused by adhesives, or damage caused by lifting, tilting and/or any attempt to position the machine other than rolling on the installed castors or feet on even surfaces, or improper use of the machine. Warranty repair or replacement by Royal Sovereign or its authorized Reseller(s) does not extend the warranty beyond the initial one year period from the date of installation. Unauthorized customer alterations will void this warranty.

CORPORATE HEADQUARTERS

Royal Sovereign International Inc.

2 Volvo Drive, Rockleigh, NJ 07647 U.S.A.

TEL : +1) 800-397-1025 FAX : +1) 201-750-1022

E-mail : info@royalsovereign.com

RS Holland B.V.

Columbusstraat 25 - 3165 AC Rotterdam,
The Netherlands

E-mail : paulchoi@royalsovereign.com

henryabrahamian@royalsovereign.com

Royal Sovereign Inc. <Oversea Sales Office>

1001, World Meridian II, 426-5, Gasan-dong,
Geumcheon-gu, Seoul, 153-759, KOREA

TEL : +82)2-2025-8800 FAX : +82)2-2025-8830

E-mail : sales@royalsovereign.com

RS Canada Inc.

164 Oakdale Road, Toronto, Ontario M3N 2S5
CANADA

TEL : +1) 416-741-8400 FAX : +1) 416-741-8185

E-mail : info@royalsovereign.com

RS International Australia PTY. LTD.

30 Prime Drive, Seven Hills, NSW 2147, Australia

TEL : +61) 2-9674-2127

FAX : +61) 2-9674-2027

E-mail : salesaust@royalsovereign.com

OWNER'S MANUAL

RSL-380 Laminator



Read all instructions carefully before use.

For any Customer Support needs please choose the
Customer Support tab on www.royalsovereign.com

Royal Sovereign International Inc.
www.royalsovereign.com

TABLE OF CONTENTS

TOPIC	PAGE
1. Introduction	3
2. Package Contents	3
3. Safety Precautions	4
4. Parts	5
5. Features Guide.....	6
6. Operation Instructions	8
7. Film Loading and Threading	8
8. Maintenance.....	11
9. Trouble Shooting Guide	12
10. Specifications	13
11. Warranty.....	14

1. INTRODUCTION

Thank you for purchasing a Royal Sovereign RSL-380 Table Top Laminator. It has been designed and manufactured to provide years of continuous service. For complete operating and maintenance information please read this instruction manual thoroughly. Upon receipt of your laminator thoroughly inspect the box, machine and all other contents. It is imperative that any shipping damage is reported and a claim is filed with the delivering carrier immediately upon receipt.

2. PACKAGE CONTENTS

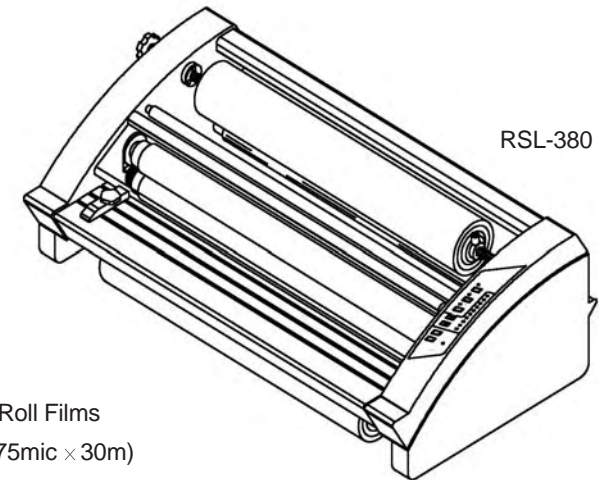

RSL-380

Preloaded Roll Films
 (350mm × 75mic × 30m)
 (14in × 3mil × 98.4ft)



SPARE FUSE (250V / 15A



Owner's Manual

3. SAFETY PRECAUTIONS

Failure to comply with any of the following safety procedures could result in serious injury. Please read the instructions carefully and keep for future reference.

1. Only a licensed electrician should install wiring and outlet for the laminator.
2. Ensure the unit is plugged into a properly grounded outlet with the correct voltage.
3. Keep hands and clothing (i.e. Neckties) away from rollers. The rollers are pinch points that can trap body parts or clothing and cause serious injury.
4. Keep flammable and wet objects away from the machine.
5. Place machine on a level surface.
6. Avoid excessive sunlight, humidity and extreme temperatures.
7. Ensure the unit is turned off, cooled, and unplugged from the outlet prior to moving and/or repairing.
8. Keep out of reach of children.
9. Only Royal Sovereign authorized maintenance and service technicians should make repairs.
10. Do not attempt to laminate items that exceed total recommended material thickness for the unit
11. When cleaning the machine, don't use flammable sprays or materials.
12. Do not touch the rollers when they are hot or place foreign objects inside the machine.
13. Do not cover the surface of the machine until the machine has completely cooled.

4. PARTS

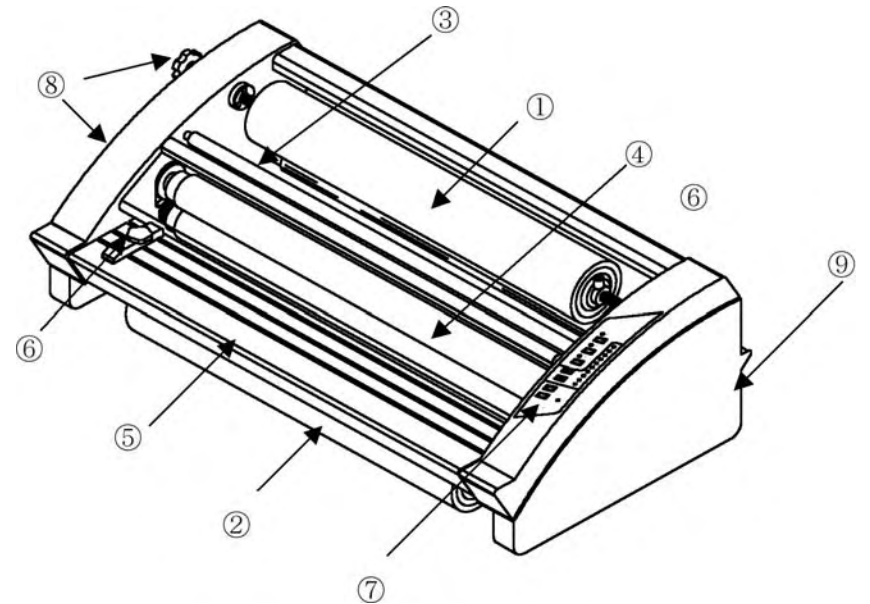

- | | | |
|-----------------|----------------|----------------|
| 1.Upper Film | 2.Lower Film | 3.Idle Bar |
| 4.Hot Rollers | 5.Feed Table | 6.Paper Guide |
| 7.Control Panel | 8.Tension Knob | 9.Power Switch |

5. FEATURES GUIDE

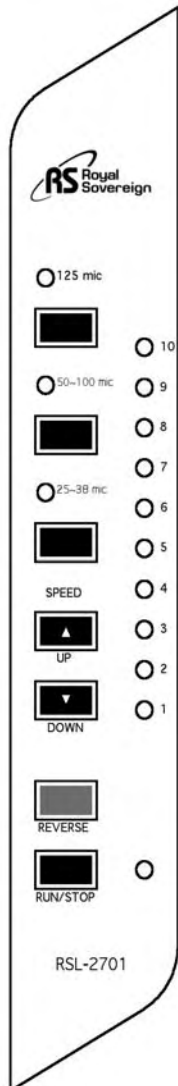

Run and stop the machine



Reverse the rollers to undo jams and correct misfed documents



Reduce roller speed (1-10 speed settings)



Increase roller speed (1-10 speed settings)

25~38mic (1~1.5mil)

Laminate 25~38mic (1~1.5mil) film

50~100mic (2~4mil)

Laminate 50~100mic (2~4mil) film

125mic (5mil)

Laminate 125mic (5mil) film

6. OPERATION INSTRUCTIONS

Power Switch (1) - Located on the rear of the machine. "1" (on) "0" (off). (Fig. 1)

Cross Cutter (2) - Used to cut off the laminated web. (Fig. 1)

Feed Guide (3) - The feed guide permits alignment of the item(s) to be laminated. To position the adjustable guide, loosen the knob, slide it to the desired position and tighten the knob to secure the feed guide in place. (Fig.2)

Safety Shield (4) - It prevents entanglement

NOTE: If the safety shield is opened, the power to the motor will turn off.

Film Shaft and Locking

Core Adapter (5) -

The film shaft holds the film supply on the machine. The locking core holds and locks the film on the shaft to prevent shifting. (Fig.3)

Film Tension Adjustment (6) - Allows the operator to increase or decrease film web tension. To increase the tension turn the knob clockwise and to decrease tension turn the knob counterclockwise. (Fig. 4)

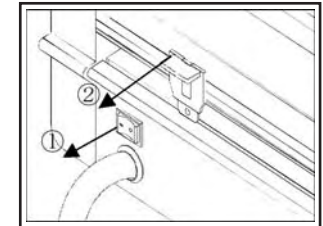

Figure 1

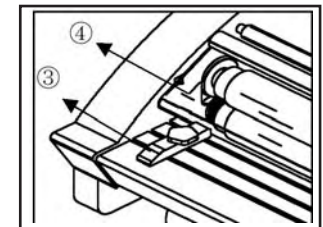

Figure 2

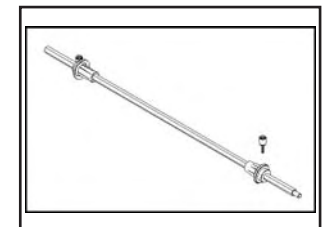

Figure 3

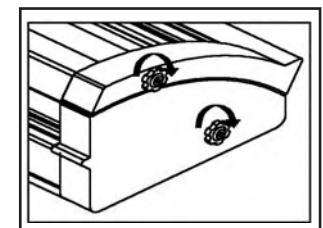

Figure 4

1. Turn the laminator ON (I) located on the rear of the machine. (Fig. 1)
2. Choose appropriate laminating thickness and speed.
3. Do not begin laminating until the blinking light is steady (approximately 10 minutes).
4. Position the item to be laminated on the feed table.
5. Press the RUN button. The rollers will begin to turn, wait for heat line to disappear, feed the item into the machine.
6. Stop the laminator when all of the items have completely exited the rear of the machine.

Repeat the above steps until all of your lamination is completed. When lamination is completed or the machine is not in use for an extended period of time turn the power off.

NOTE: Stand by mode and auto power off mode

- Stand by mode: If no activity is made within 30 minutes after each use the machine will automatically switch into stand by mode. (In stand-by mode the temperature will decrease to 80~90°... (176~194°F) and the three film thickness setting indicators will blink).
- Auto power off mode: If the machine is in stand by mode and no activity is made for 60 minutes the machine will automatically power off.
- If any activity is made while in stand by or auto power off mode the machine will return to it's previous settings.

7. FILM LOADING & THREADING

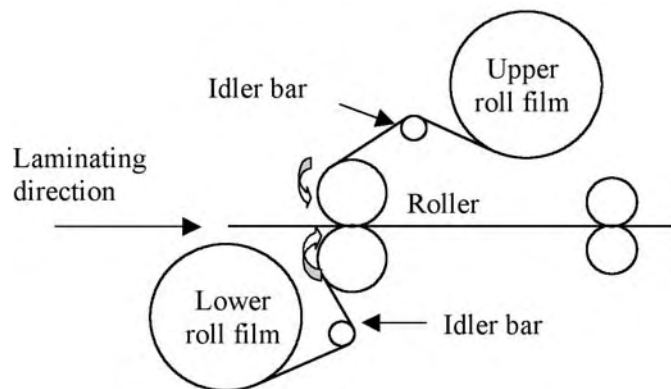

▲ LOADING UPPER ROLL FILM

1. Slightly slide the shaft to the right and pull it out from the machine.

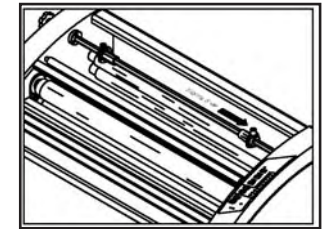

Figure 1

2. Take both lock core adapters off of the shaft

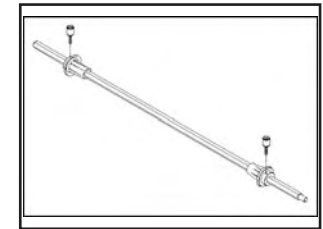

Figure 2

3. Insert one of the core adapters into the right end of the film core. For film with poly-in (adhesive side is inside the web), make sure the adhesive side is facing upward. (Fig.3)

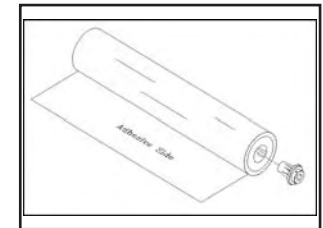

Figure 3

4. Insert the film shaft into the roll of film from the right side with the copper end last. Align and insert the core adapter on the left end of the film core

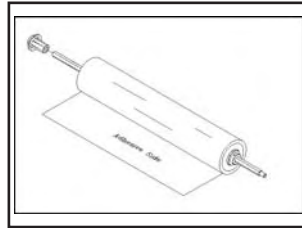

Figure 1

5. Center the film on the shaft and lock it in place with the locking core adapters

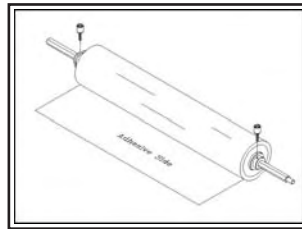

Figure 2

6. Carefully return the film shaft back into place.

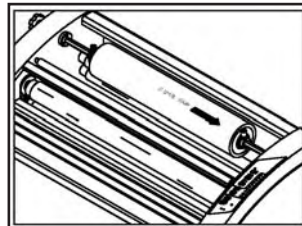

Figure 3

▲ LOADING LOWER ROLL FILM

1. Repeat steps 1-5 to load the lower roll film.
2. Once the upper and lower film is on the shaft, pull the film from the top and roll down to the bottom roll to make certain that the film is aligned properly. Then tighten the lower locking core screws.

NOTE: If the film is not aligned properly exposed adhesive will adhere to the rollers and may cause the film to jam.

FILM THREADING

Refer to Figure 6

8. MAINTENANCE

1. Do not apply any cleaning fluids to the rollers. Certain fluids may damage the rollers.
2. Do not clean rollers with sharp or pointed objects.
3. Use adhesive remover to clean resin off of the rollers.
4. Use a damp cloth with water to clean the body of the machine.
5. Store machine in a dry clean area

9. TROUBLE SHOOTING GUIDE

Problem	Cause	Remedy
Rollers do not operate after the RUN/STOP button is pressed	<ol style="list-style-type: none"> 1.Safety cover is open 2. Power cord is not plugged in 3.Machine is not turned on 	<ol style="list-style-type: none"> 1. Check safety cover is properly closed 2. Plug in the power cord 3. Turn the machine on
Roller is not heating	Call your authorized dealer	Call your authorized dealer
Poor Lamination	<ol style="list-style-type: none"> 1. Film tension is unbalanced. 2. Lower idler bar is not located in proper position 3.Wrong temperature/ speed setting 	<ol style="list-style-type: none"> 1. Adjust film tension 2. Push idler bar in proper position 3. Follow manufacturers recommended temperature and speed

10. SPECIFICATIONS

Description	RSL-380
Power supply	AC 100,200,220~240V 50 / 60Hz 120V 60Hz
Power consumption	1200W
Max laminating width	350mm / 14"
Film thickness	25~125 mic / 1~5mil
Max laminating speed	3m/min / 9.9ft/min
Ready time	10 min
Heating method	Hot Roller
Driving motor	DC geared motor
Temperature control	Digital(micom)
Speed control	10 settings
Transport type	4 Roller
Cooling system	No
Side cutter	No
Cross cutter	Yes
Film alignment	No
Hot lamination	Yes
Cold lamination	No
Reverse	Yes
Dimensions (w × d × h)	550 × 520 × 320(mm) / 21.7" × 20.5" × 12.6"
Unit weight	30kg / 66.1lbs