

**Warranty
Registration**
Register online today for a
chance to win a FREE
Tripp Lite product!
www.tripplite.com/warranty

Owner's Manual

Traffic MOVE-UPS™ (TMU) Uninterruptible Power Supplies (UPS Systems)



1111 W. 35th Street, Chicago, IL 60609 USA
Customer Support: (773) 869-1234
www.tripplite.com

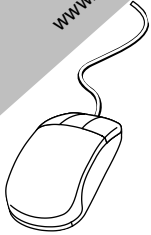

	Input	Output
Invert:	12 VDC	120V, 60 Hz. AC
Charge:	120V, 60 Hz. AC	12 VDC

Reliable Backup Power for Traffic Signals and Security/Wireless Equipment

Congratulations! You've purchased one of the most reliable and cost-effective outdoor uninterruptible power supplies for supporting and protecting traffic signals, airport security, access security and wireless equipment. Traffic MOVE-UPS UPS systems keep traffic moving and citizens safer by keeping mission-critical systems up during power outages. Traffic MOVE-UPS models help ensure vital systems preparedness and security during disasters, terror incidents and routine power disruptions, mitigating tort liability for municipalities, states and other governmental and corporate units. Traffic MOVE-UPS UPS systems provide traffic signals and security/wireless equipment with utility-supplied AC electricity (filtered through premium ISOBAR® power conditioning) whenever available. Whenever power blackouts, brownouts or high voltages occur, Traffic MOVE-UPS models immediately and automatically switch over to invert battery output (DC-to-AC) to power your connected equipment. In addition, Traffic MOVE-UPS models continuously and reliably recharge your connected battery banks.

Rugged Reliability for All Indoor/Outdoor Applications

- Heavy-duty, weather-resistant construction*
- Moisture-resistant, conformally-coated circuit boards*
- Compact size for tight controller cabinets

Premium Protection for Critical Equipment

- Built-in ISOBAR® power conditioning: spike, surge, low voltage, high voltage and lightning protection
- Rapid-recharge, high-amp, 3-stage battery charger
- Rapid, automatic transfer switching (from line power to inverter power)
- Automatic overload protection
- Relay for low battery alarm, flashing red mode (traffic signals)**

Cost-Effective Features for All Budgets

- Power-saving, high-efficiency DC-to-AC inversion
- Maintenance-free operation
- Compatible with economical off-shelf accessories: bypass switch, battery heaters, standard 12V batteries, generator receptacles, NEMA cabinets, etc.
- 12V DC input—allows for easy tie-in of automobile or maintenance truck power via jumper cables in event of prolonged outages
- Dead Battery Startup
- Ignition Interlock & In/Out Swap Protection

Contents

Warranty/Warranty Registration	2	Configuration	6-7
Service & Maintenance	2	Mounting	8
Safety	3	Battery Selection	9
Feature Identification	4	Battery Connection	10
Operation	5	AC Input/Output Connection	11
		Troubleshooting	12

*TMU Systems are moisture-resistant, not waterproof. ** Available on all models except 612 models.
Copyright © 2004. Traffic MOVE-UPS™ is a trademark of Tripp Lite. All rights reserved.

Limited Warranty

Tripp Lite warrants its UPS Systems to be free from defects in materials and workmanship for a 30 month period from the date of retail purchase by end user.

Tripp Lite's obligation under this warranty is limited to repairing or replacing (at its sole option) any such defective products. To obtain service under this warranty you must obtain a Returned Material Authorization (RMA) number from Tripp Lite or an authorized Tripp Lite service center. Products must be returned to Tripp Lite or an authorized Tripp Lite service center with transportation charges prepaid and must be accompanied by a brief description of the problem encountered and proof of date and place of purchase. This warranty does not apply to equipment which has been damaged by accident, negligence or misapplication or has been altered or modified in any way, including opening of the unit's casing for any reason. This warranty applies only to the original purchaser who must have properly registered the product within 10 days of retail purchase.

EXCEPT AS PROVIDED HEREIN, TRIPP LITE MAKES NO WARRANTIES, EXPRESS OR IMPLIED, INCLUDING WARRANTIES OF MERCHANTABILITY AND FITNESS FOR A PARTICULAR PURPOSE. Some states do not permit limitation or exclusion of implied warranties; therefore, the aforesaid limitation(s) or exclusion(s) may not apply to the purchaser.

EXCEPT AS PROVIDED ABOVE, IN NO EVENT WILL TRIPP LITE BE LIABLE FOR DIRECT, INDIRECT, SPECIAL, INCIDENTAL OR CONSEQUENTIAL DAMAGES ARISING OUT OF THE USE OF THIS PRODUCT, EVEN IF ADVISED OF THE POSSIBILITY OF SUCH DAMAGE. Specifically, Tripp Lite is not liable for any costs, such as lost profits or revenue, loss of equipment, loss of use of equipment, loss of software, loss of data, costs of substitutes, claims by third parties, or otherwise.

Tripp Lite has a policy of continuous improvement. Specifications are subject to change without notice.

Warranty Registration

Visit www.tripplite.com/warranty to register the warranty of your new Tripp Lite product. You'll be automatically entered into a drawing for a chance to win a FREE Tripp Lite product!*

* No purchase necessary. Void where prohibited. Some restrictions apply. See website for details

Service & Maintenance

Service: Before returning your UPS System for service, follow these steps: 1.) Review the installation and operation instructions to ensure that the service problem does not originate from a misreading of the instructions. Also, check that the circuit breaker(s) are not tripped.* 2.) If the problem continues, do not contact or return the UPS System to the dealer. Instead, call Tripp Lite at (773) 869-1233. A service technician will ask for the UPS System's model number, serial number and purchase date and will attempt to correct the problem over the phone. 3.) If the problem requires service, the technician will issue you a Returned Material Authorization (RMA) number, which is required for service. Securely pack the UPS System to avoid damage during shipping. Do not use Styrofoam beads for packaging.** Any damages (direct, indirect, special, incidental or consequential) to the UPS System incurred during shipment to Tripp Lite or an authorized Tripp Lite service center is not covered under warranty. UPS Systems shipped to Tripp Lite or an authorized Tripp Lite service center must have transportation charges prepaid. Mark the RMA number on the outside of the package. If the UPS System is within the warranty period, enclose a copy of your sales receipt. Return the UPS System for service using an insured carrier to the address given to you by the Tripp Lite service technician.

* This is a common cause of service inquiries which can be easily remedied by following the resetting instructions in this manual. ** If you require packaging, the technician can arrange to send you proper packaging.

Maintenance: Your UPS System requires no maintenance and contains no user-serviceable or replaceable parts, but should be kept dry at all times. Periodically check, clean and tighten all cable connections, as necessary, both at the unit and at the battery.



SAVE THESE INSTRUCTIONS!

This manual contains important instructions and warnings that should be followed during the installation, operation and storage of all Tripp Lite UPS Systems.

Location Warnings

- Install your UPS System (whether for a mobile or stationary application) in a location or compartment that minimizes exposure to heat, dust, direct sunlight and moisture.
- Although your UPS System is moisture resistant, it is NOT waterproof. Flooding the unit with water will cause it to short circuit and could cause personal injury due to electric shock. Never immerse the unit, and avoid any area where standing water might accumulate. Mounting should be in the driest location available.
- Leave a minimum of 2" clearance at front and back of the UPS System for proper ventilation. To avoid automatic UPS System shutdown due to overtemperature, any compartment that contains the UPS System must be properly ventilated with adequate outside air flow. The heavier the load of connected equipment, the more heat will be generated by the unit.
- Do not install near flammable materials, fuel or chemicals.

Battery Connection Warnings

- The UPS System will not operate (with or without utility power) until batteries are connected.
- Multiple battery systems must be comprised of batteries of identical voltage, age, amp-hour capacity and type.
- Because explosive hydrogen gas can accumulate near batteries if they are not kept well ventilated, your batteries should not be installed (whether for a mobile or stationary application) in a “dead air” compartment. Ideally, any compartment would have some ventilation to outside air.
- Sparks may result during final battery connection. Always observe proper polarity as batteries are connected.
- Do not allow objects to contact the two DC input terminals. Do not short or bridge these terminals together. Serious personal injury or property damage could result.

Equipment Connection Warnings

Do not use a Tripp Lite UPS System in life support or healthcare applications where a malfunction or failure of a Tripp Lite UPS System could cause failure of, or significantly alter the performance of, a life support device or medical equipment.

- Corded models: Do not modify the UPS System’s plug or receptacle in a way that eliminates its ground connection. Do not use power adapters that will eliminate the plug’s ground connection.
- Connect your UPS System only to a properly grounded AC power outlet or hardwired source. Do not plug the unit into itself; this will damage the device and void your warranty.
- You may experience uneven performance results if you connect a surge suppressor, line conditioner or UPS system to the output of the UPS System.

Operation Warnings

- Your UPS System does not require routine maintenance. Do not open the device for any reason. There are no user serviceable parts inside.
- Potentially lethal voltages exist within the UPS System as long as the battery supply and/or AC input are connected. During any service work, the battery supply and AC input connection (if any) should therefore be disconnected.
- Do not connect or disconnect batteries while the UPS System is operating in either inverting or charging mode. Dangerous arcing may result. Operating Mode Switch should be in the OFF position.

Feature Identification

Identify the premium features on your specific model and quickly locate instructions on how to maximize their use.

- 1 Configuration DIP Switches:** optimize UPS System operation depending on your application. See Configuration section for setting instructions.
- 2 Operating Mode Switch:** controls UPS System operation. See Operation section for setting instructions.
- 3 “LINE”, “INVERT”, “LOAD” LEDs:** show whether the UPS System is operating from AC line power or DC battery power. It also warns you if the connected equipment load is too high. See Operation section for instructions on reading the indicator lights.
- 4 “BATT VOLT/CHRG CURR” LEDs:** these three lights will turn ON in several sequences to show two separate operational conditions depending on the position of the Operating Mode Switch. See Operation section for instructions on reading indicator lights.
- 5 DC Power Terminals:** connect to your battery terminals. See Battery Connection section for instructions.
- 6 AC Receptacles (not on hardwire models):** allow you to connect equipment that would normally be plugged into a utility outlet.
- 7 AC Input Cord (not on hardwire models):** connects the UPS System to any source of utility- or generator-supplied AC power. See AC Input/Output Connection section for instructions.
- 8 Hardwire AC Input/Output Terminals (not on corded models):** securely connect the UPS System to electrical system input and equipment output. See AC Input/Output Connection section for instructions.
- 9 Resettable Circuit Breaker:** protect your UPS System against damage due to overload. See Operation section for resetting instructions.

- 10 Main Ground Lug:** properly grounds the UPS System to earth ground. See Configuration section for instructions.
- 11 Multi-Speed Cooling Fan:** quiet, efficient fan prolongs equipment service life.
- 12 Hardwire AC Input/Output Cover Plate**
- 13 Battery Temperature Sensing Connector (not on TMU612 models):** prolongs battery life by adjusting charge based on battery temperature. Use with included cable. See Configuration section for details.
- 14 Low Battery Relay (not on TMU612 models):** when battery reaches low voltage, this relay can signal traffic controller to go to flashing red mode or to send low battery alert to your control center. See Configuration section for details.

Optional Features for alternate uses of Tripp Lite Traffic MOVE-UPS

Tripp Lite’s TMU UPS models are versatile and can be used in mobile applications as well, such as running AC power tools in municipal maintenance trucks or police command vehicles. The features listed below are available for such alternate uses.

- 15 Remote Control Module Connector:** designed only for mobile applications, this connector allows remote control from up to 50 feet away with optional module, sold separately. If required, contact Tripp Lite for further information.
- 16 Load Sense Dial (not on TMU612 models):** designed only for mobile applications, this dial sets the low load level at which the UPS System’s inverter automatically shuts down. To guard against inadvertent inverter shutdown, Tripp Lite recommends you leave the dial in its factory default setting (fully clockwise). If required, contact Tripp Lite for further information.

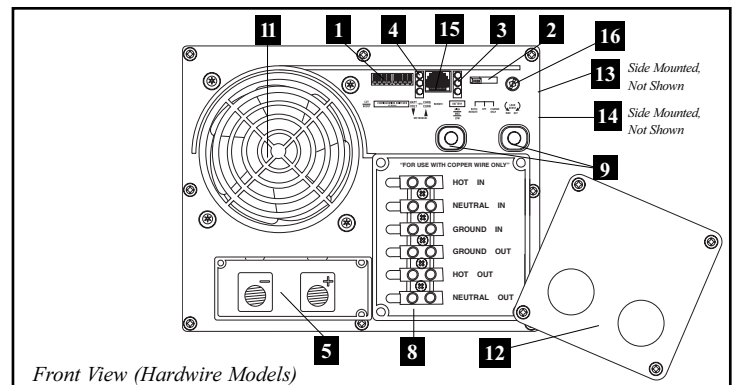
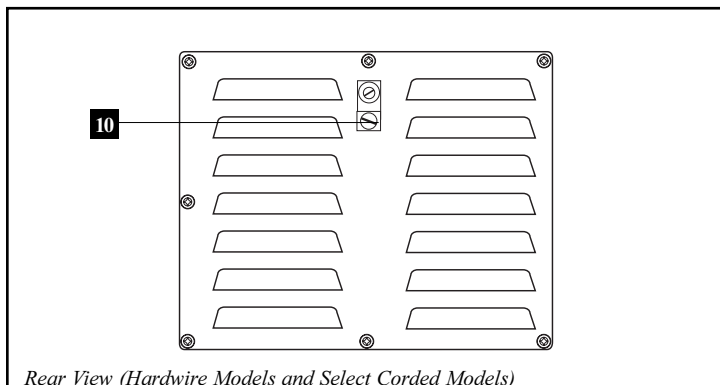
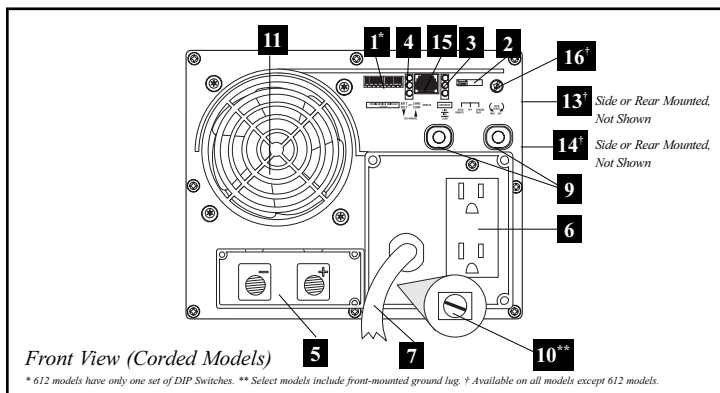

Switch Modes

After configuring, mounting and connecting your UPS System, you are able to operate it by switching between the following operating modes as appropriate to your situation:

AUTO/REMOTE: Switch to this mode when you need constant, uninterrupted AC power for connected lights, controllers or other equipment. Properly installed and maintained, the UPS System will continue to pass-through AC power to connected equipment and to charge your connected batteries while utility- or generator-supplied AC power is present. Since the inverter is ON (but in Standby) in this mode, it will automatically switch to your battery system to supply inverter AC power to connected equipment in the absence of a utility/generator source or in over/under voltage situations, such as in blackouts or brownouts.

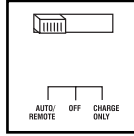

OFF: Switch to this mode to shut down the UPS System completely, preventing the inverter from drawing power from the batteries, and preventing utility AC from passing through to connected equipment or charging the batteries. Use this switch to automatically reset the unit if it shuts down due to overload or overheating. First remove the excessive load or allow the unit to sufficiently cool (applicable to your situation). Switch to “OFF”, then back to “AUTO/REMOTE”. If unit fails to reset, remove more load or allow unit to cool further and retry.

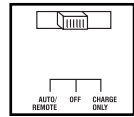

Optional Feature for Alternate Use of Tripp Lite Traffic MOVE-UPS. CHARGE ONLY: The “Charge-Only” setting is designed only for mobile applications, not for traffic signal or security/wireless applications. When the UPS System is switched to this position, the inverter will be disabled and battery backup power will not be supplied during a blackout, brownout or overvoltage.

Indicator Lights

“LINE Green LED”: If the operating mode switch is set to “AUTO/REMOTE”, this light will ILLUMINATE CONTINUOUSLY when your connected equipment is receiving continuous AC power supplied from a utility/generator source.

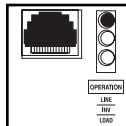

If the operating mode switch is set to “CHARGE ONLY”, this light will BLINK to alert you that the unit’s inverter is OFF and will NOT supply AC power in the absence of a utility/generator source or in over/under voltage situations.

“INV” (Inverting) Yellow LED: This light will ILLUMINATE CONTINUOUSLY whenever connected equipment is receiving battery-supplied, inverted AC power (in the absence of a utility/generator source or in over/under voltage situations). This light will be off when AC power is supplying the load. This light will BLINK to alert you if the load is less than the Battery Charge Converter (Load Sense) setting.

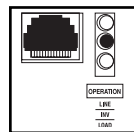

“LOAD” Red LED: This red light will ILLUMINATE CONTINUOUSLY whenever the inverter is functioning and the power demanded by connected equipment exceeds 100% of load capacity. (Be sure to size your UPS model properly for the traffic signal or other loads it is expected to support.) The light will BLINK to alert you when the inverter shuts down due to a severe overload or overheating. If this happens, turn the operating mode switch “OFF”; remove the overload and let the unit cool. You may then turn the operating mode switch to “AUTO/REMOTE” after it has adequately cooled. This light will be off when AC power is supplying the load.

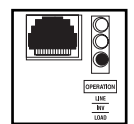

“BATT VOLT/CHRG CURR” LEDs: If the switch is in the “AUTO/REMOTE” position (normal setting for traffic applications), the LEDs indicate the approximate charge level and voltage of your connected battery bank and alert you to several fault conditions. See Chart for charge and voltage levels.*

* When used in alternate mobile applications, the LEDs can indicate charge rate when the Operating Mode Switch is in the “Charge-Only” position. However, in traffic signal or security/wireless applications, the Operating Mode Switch should never be set to the “Charge-Only” position.

LED Function with Switch in “AUTO/REMOTE” Position

Approximate Battery Charge Level*

LEDs Illuminated	Battery Capacity (Charging/Discharging)
1 Green	91%–Full
2 Green & Yellow	81%–90%
3 Yellow	61%–80%
4 Yellow & Red	41%–60%
5 Red	21%–40%
6 All three lights off	1%–20%
7 Flashing red	0% (Inverter shutdown)**

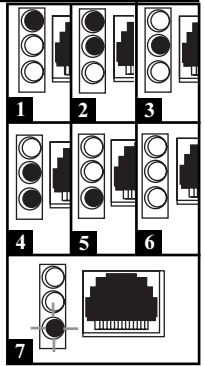

* Charge levels listed are approximate. Actual conditions vary depending on battery condition and load. ** Inverter shutdown protects battery against damage due to excessive discharge.

Fault Condition

LEDs Illuminated	Fault Condition
1 All three lights flash slowly*	Excessive discharge (Inverter shutdown)
2 All three lights flash quickly**	Overcharge (Charger shutdown)

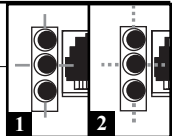

* Approximately ½ second on, ½ second off. See Troubleshooting section. Inverter shutdown protects battery against damage due to excessive discharge. ** Approximately ¼ second on, ¼ second off. Charger shutdown protects battery against damage due to overcharge. May also indicate a battery charger fault exists. See Troubleshooting section.

Resetting Your UPS System to Restore AC Power

Your UPS System may cease supplying AC power or DC charging power under certain conditions, especially in order to protect itself from overload or to protect your electrical system. To restore normal functioning:

Overload Reset: Switch operating mode switch to “OFF” and remove some of the connected electrical load (ie: turn off some of the AC devices drawing power which may have caused the overload of the unit). Wait one minute, then switch operating mode switch back to “AUTO/REMOTE.”

Output Circuit Breaker Reset: Alternatively, check output circuit breaker(s) on the unit's front panel. If tripped, remove some of the electrical load, then wait one minute to allow components to cool before resetting the circuit breaker. See Troubleshooting for other possible reasons AC output may be absent.

Check Battery Voltage: Your UPS is designed to keep your connected batteries constantly charged, so long as utility/generator power is present. In the absence of utility/generator power, or as a result of poor battery maintenance, low battery voltage may prevent AC output. As applicable, recharge or replace battery.

Configuration

Set Configuration DIP Switches

Using a small tool, set the Configuration DIP Switches (located on the front panel, see diagram) to optimize UPS System operation, depending on your application. TMU612 models include one set of four DIP Switches. All other models include an additional set of four DIP switches to configure additional operational functions. Refer to the appropriate section to review the instructions for your specific model.

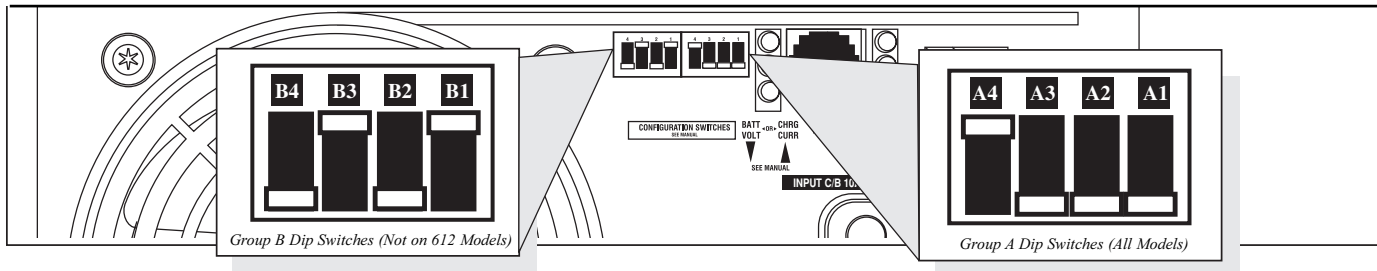

Group A DIP Switches (All Models)

Using a small tool, configure your UPS System by setting the four Group A DIP Switches (located on the front panel of your unit; see diagram) as follows:

A1 Select Battery Type—REQUIRED (All models)

CAUTION: The Battery Type DIP Switch setting must match the type of batteries you connect, or your batteries may be degraded or damaged over an extended period of time. See "Battery Selection," p. 9 for more information.

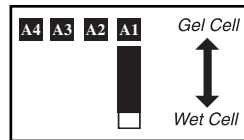

Battery Type	Switch Position
Gel Cell (Sealed) Battery	Up
Wet Cell (Vented) Battery	Down (factory setting)

A2 Select High AC Input Voltage Point for Switching to Battery—OPTIONAL* (All models except TMU1250)

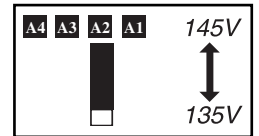

Voltage	Switch Position
145V	Up
135V	Down (factory setting)

TMU1250 Only

Select Charger Enable/Inhibit

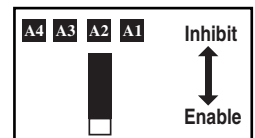

Status	Switch Position
Inhibit	Up
Enable	Down (factory setting)

All Models Except TMU612

A4 & A3 Select Low AC Input Voltage Point for Switching to Battery—OPTIONAL*

Voltage	Switch Position
105V	#A4 Up & #A3 Up
95V	#A4 Up & #A3 Down
85V	#A4 Down & #A3 Up
75V	#A4 Down & #A3 Down (factory setting)

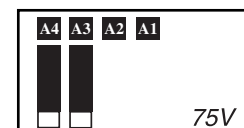
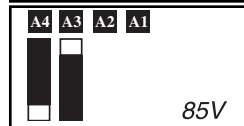
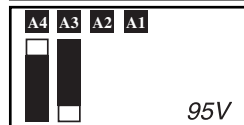
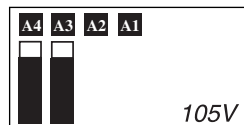

TMU612 Only

A4 & A3 Settings

A3 Select Low AC Input Point for Switching to Battery—OPTIONAL

Voltage	Switch Position
105V	Up
95V	Down (factory setting)

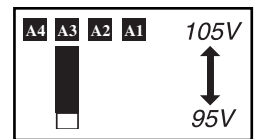

A4 Set Battery Charging Amps Type—OPTIONAL

Check specifications on for your unit's high- and low-charging amp options. By setting on high charging, your batteries will charge at maximum speed. When setting on low charging, you lengthen the life of your batteries (especially smaller ones).

Battery Charger	Switch Position
High Charge Amp	Up
Low Charge Amp	Down (factory setting)*

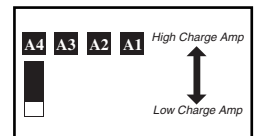

* Most of your connected equipment will perform adequately when your UPS System's High AC Input Voltage Point (DIP Switch #2 of Group A) is set to 135V and its Low AC Voltage Input Point (DIP Switches #3 and #4 of Group A or DIP Switch #3 for 612 models) are set to 95V. However, if the unit frequently switches to battery power due to momentary high/low line voltage swings that would have little effect on equipment operation, you may wish to adjust these settings. By increasing the High AC Voltage Point and/or decreasing the Low AC Voltage Point, you will reduce the number of times your unit switches to battery due to voltage swings.

Configuration *(continued)*

Group B DIP Switches (1012 and 2012 Models Only)

B1 B2 Select Load Sharing—OPTIONAL

Your UPS System features a battery charger that can draw a significant amount of AC power from your utility source or generator when charging at its maximum rate. To help ensure that your unit is supplying sufficient AC power rating to its connected electrical loads, the charger's draw is limited by factory settings as indicated below. Tripp Lite advises against altering these settings in traffic signal UPS applications. Failure to limit the charger's draw in combination with undersizing the UPS for connected loads could trip the AC input circuit breaker, resulting in interruption of pass-through utility power. To keep the sum of the unit's AC load and charge power within the circuit breaker rating, this charger-limiting function has four settings, allowing you to reduce the charger's draw lower and lower, as needed, if the AC input circuit breaker keeps tripping under the normal AC loads of devices you have connected downline from the unit. The figures show how to set your DIP Switches to determine how heavy the connected load can be on your UPS System before charger-limiting begins.

Select Battery Charger-Limiting Points—OPTIONAL

“Most Limiting” (#B2 & #B1 Up, factory setting for 2012 and 1012 models): Charger-limiting takes effect the moment any 120V AC load is applied; charger output falls gradually from full output at no 120V load passing through to no output at full load.

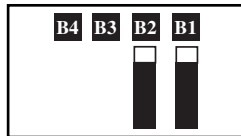

“Less Limiting” (#B2 Up & #B1 Down): Charger-limiting begins when the UPS System's load reaches 33% of the UPS System's load rating. Charger output falls gradually from full output at 33% of the UPS System's load rating to about 40% of full output at full load.

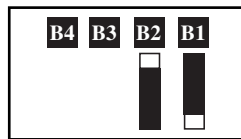

“Least Limiting” (#B2 Down & #B1 Up, applicable only to 2012 models): Charger-limiting begins when the UPS System's load reaches 66% of the UPS System's load rating. Charger output falls gradually from full output at 66% of the UPS System's load rating to about 40% of full output at full load. This setting IS NOT recommended for traffic signal UPS applications

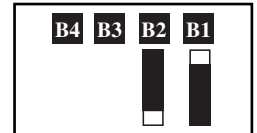

“No Limiting” (#B2 & #B1 Down): No charger-limiting occurs at any load size.

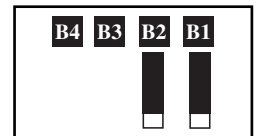

Note: On TMU612 and TMU1250 models, these DIP Switches are non-functional.

B3 Select Equalize Battery Charge—OPTIONAL (Not on 612 Models)

This DIP Switch is momentarily engaged to begin the process of equalizing the charge state of your battery's cells by time-limited overcharge of all cells. This can extend the useful life of certain types of batteries; consult with your battery's manufacturer to determine if your batteries could benefit from this process. The charge equalization process is automatic; once started, it can only be stopped by removing the input power.



Setting Procedure

- Move to “Equalize” (DOWN) position for three seconds.
- Move to “Reset” (UP) position and leave it there. This is the factory default setting.

CAUTION: Do not leave DIP switch #B3 in the down position after beginning process. Battery charge equalization should only be performed in strict accordance with the battery manufacturer's instructions and specifications.

Battery Charge	Switch Position
Reset	Up (factory setting)
Equalize	Down—momentarily

B4 Set Battery Charging Amps—OPTIONAL (function included on A4 switch on 612 models)

For traffic signal UPS applications, confirm that the setting is on low charging to lengthen the life of your batteries (especially smaller ones), which is advisable in traffic signal UPS applications. By setting on high charging, your batteries will charge at maximum speed, which may

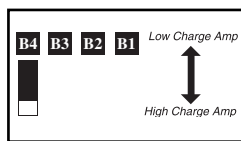

appear for mobile applications. Check specifications for your unit's high- and low-charging amp options.

Battery Charger Switch Position

Low Charge Amps	Up (factory setting)
High Charge Amps	Down

CAUTION: When switching to the High Charge Amp setting, the user must ensure that the amp hour capacity of their battery system exceeds the amperage of the High Charge Amp setting or the batteries may be damaged or degraded.

Connect Battery Temperature Sensing Cable (1012 and 2012 models only)

The battery temperature sensing function prolongs battery life by adjusting the charge float voltage level based on battery temperature. Connect the sensor cable (the cable, included with select models, has an RJ style connector on one end and a black sensor on the other) to the RJ style jack located on the side of the UPS System labeled “Remote Temp. Sense.” With user-supplied electrical or duct tape, affix the sensor to the side of the battery below the electrolyte level. Make sure that nothing, not even tape, comes between the sensor and the side of the battery. To guard against false readings due to ambient temperature, place the sensor between batteries, if possible, or away from sources of extreme heat or cold. If the sensor cable is not used, the UPS System will charge according to its default 25° C values.

Utilize Low Battery Relay for Flashing-Red Mode or Alarm Capability—OPTIONAL (1012 and 2012 models only) All models except 612 models include an RJ type modular jack on the side panel. Attach to a user-supplied cable and relay. Once attached, the interface will allow the UPS System to automatically relay alarms to a controller station indicating that connected battery systems are nearly depleted, to enable the controller to switch to flashing-red mode and/or send a low battery alarm to a central control monitor.

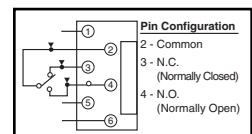

Mounting



WARNING! Mount your UPS System BEFORE DC battery and AC power connection. Failure to follow these instructions may lead to personal injury and/or damage to the UPS System and connected systems.

Tripp Lite manufactures a variety of UPS Systems with a variety of mounting options. Tripp Lite recommends permanent mounting of your UPS System in any of the configurations illustrated below. User must supply mounting hardware and is responsible for determining if the hardware and mounting surface are suitable to support the weight of the UPS System. Contact Tripp Lite if you require further assistance in mounting your UPS System.

Horizontal Mount

(612 & 1250 models only)

A Using the measurements from the diagram, install two user-supplied 1/4" (6 mm) fasteners into a rigid horizontal surface, leaving the heads slightly raised. **B** Slide the UPS System back over the fasteners to engage the mounting slots molded on the bottom of the UPS System cabinet. **C** Install and tighten two user-supplied 1/4" (6 mm) fasteners into the mounting feet molded on the front of the UPS System cabinet.

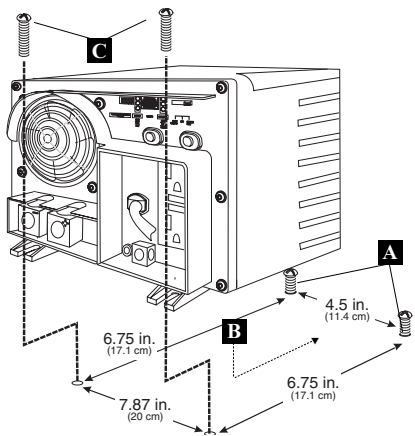

Horizontal Mount

(1012 and 2012 models only)

A Using the measurements from the diagram, install two user-supplied 1/4" (6 mm) fasteners into a rigid horizontal surface, leaving the heads slightly raised. **B** Slide the UPS System forward over the fasteners to engage the mounting feet molded on the front of the UPS System cabinet. Install and tighten additional user-supplied 1/4" (6 mm) fasteners into the mounting feet molded on the rear and sides of the UPS System cabinet*. The rear feet extend beyond the unit's cabinet to provide for adequate ventilation space behind the cooling fan(s); they should not be removed.

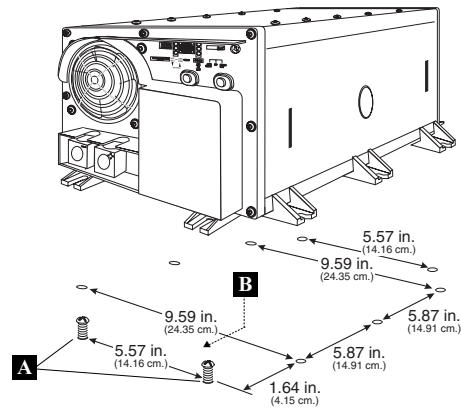

Note: Cabinets may have different front panel features, but all mount as per the figure above, or via the Lateral Mounting Bracket, illustrated at left.

* All models include front and rear mounting feet. Select models include side mounting feet.

Battery Selection

Select Battery Type

Select batteries suitable for functionality within the ambient temperature ranges of your battery or traffic signal controller cabinets. Select “Deep Cycle” batteries to receive optimum performance from your UPS System. For lower initial costs in extreme climates, ordinary car or starting batteries or batteries rated in Cold Cranking Amps (CCA) may appeal, but are likely to offer a more limited number of backup events prior to failing (in which event AC output power would be interrupted). If the batteries you connect to the UPS System are not true Deep Cycle batteries, their operational lifetimes may be significantly shortened. Batteries of either Wet-Cell (vented) or Gel-Cell /Absorbed Glass Mat (sealed) construction are ideal. 6-volt “golf cart”, Marine Deep-Cycle or 8D Deep-Cycle batteries are also acceptable. You must set the UPS System’s Battery Type DIP Switch (see Configuration section for more information) to match the type of batteries you connect or your batteries may be degraded or damaged over an extended period of time.

Match Battery Amp-Hour Capacity to Your Application

Select a battery or system of batteries that will provide your UPS System with proper DC voltage and an adequate amp-hour capacity to power your application. Even though Tripp Lite UPS Systems are highly efficient at DC-to-AC inversion, their rated output capacities are limited by the total amp-hour capacity of connected batteries.

NOTE: Unlike various competitors, Tripp Lite Traffic MOVE-UPS models operate on 12V input. In the event of prolonged power outages that exceed battery backup time, this design allows for easy tie-in of 12V power from a police cruiser or maintenance truck via jumper cables, to keep crucial traffic signals from going dark. This flexibility, in turn, may allow traffic managers to feel comfortable with fewer battery amp-hours and shorter back-up times, thereby minimizing budgetary outlays for batteries, auxiliary cabinets and battery maintenance.

• STEP 1: Determine Total Wattage Required

Add the wattage ratings of all equipment you will connect to your UPS System. Wattage ratings are usually listed in equipment manuals or on nameplates. If your equipment is rated in amps, multiply that number times AC utility voltage to determine watts.

Note: Your UPS System will operate at higher efficiencies at about 75% - 80% of nameplate rating.

• STEP 2: Determine DC Battery Amps Required

Divide the total wattage required (from step 1, above) by the battery voltage (12) to determine the DC amps required.

• STEP 3: Estimate Battery Amp-Hours Required

Multiply the DC amps required (from step 2, above) by the number of hours you estimate you will operate your equipment exclusively from battery power before you have to recharge your batteries with utility- or generator-supplied AC power. Compensate for inefficiency by multiplying this number by 1.2. This will give you a rough estimate of how many amp-hours of battery power (from one or several batteries) you should connect to your UPS System.

NOTE! Battery amp-hour ratings are usually given for a 20-hour discharge rate. Actual amp-hour capacities are less when batteries are discharged at faster rates. For example, batteries discharged in 55 minutes provide only 50% of their listed amp-hour ratings, while batteries discharged in 9 minutes provide as little as 30% of their amp-hour ratings.

• STEP 4: Estimate Battery Recharge Required, Given Your Application

You must allow your batteries to recharge long enough to replace the charge lost during inverter operation or else you will eventually run down your batteries. To estimate the minimum amount of time you need to recharge your batteries given your application, divide your required battery amp-hours (from step 3, above) by your UPS System’s rated charging amps (see Specifications section).

Battery Connection

Connect your UPS System to your batteries using the following procedures:

• **Connect DC Wiring:** Though your UPS System is a high-efficiency device, its rated output capacity is limited by the length and gauge of the cabling running from the battery to the unit. Use the shortest length and largest diameter cabling (maximum 2/0 gauge) to fit your UPS System's DC Input terminals. Shorter and heavier gauge cabling reduces DC voltage drop and allows for maximum transfer of current. Your UPS System is capable of delivering peak wattage at up to 200% of its rated continuous wattage output for brief periods of time. See Specifications page for details. Heavier

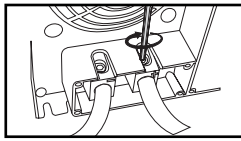

DC Connectors

gauge cabling should be used when continuously operating heavy draw equipment under these conditions. Tighten your UPS System and battery terminals to approximately 3.5 Newton-meters of torque to create an efficient connection and to prevent excessive heating at this connection. Insufficient tightening of the terminals could void your warranty. **See Specifications page for Minimum Recommended Cable Sizing Chart.**

• **Connect Ground:** Using a #8 AWG wire or larger directly connect the Main Ground Lug to earth ground. See the Feature Identification section to locate the Main Ground Lug on your specific UPS System model.

All installations must comply with national and local codes and ordinances.

• **Connect Fuse:** NEC (National Electrical Code) article 551 requires that you connect all of your UPS System's positive DC Terminals directly to a UL-listed fuse(s) and fuse block(s) within 18 inches of the battery. The fuse's rating must equal or exceed the Minimum DC Fuse Rating listed in your UPS System's specifications. See Specifications for fuse and fuse block recommendations. See diagrams below for proper fuse placement.



WARNING!

- Failure to properly ground your UPS System to earth ground may result in a lethal electrical shock hazard.
- Never attempt to operate your UPS System by connecting its DC terminals directly to output from a generator rather than a battery or battery bank.
- Observe proper polarity with all DC connections.

In a parallel connection, your UPS System's Nominal DC Input Voltage (12V DC) **must match** the voltage of your battery or batteries (12V DC). In a series connection, your UPS System's Nominal DC Input Voltage **must match** the number of batteries multiplied by their voltage. For example, a 12V DC UPS System would require two 6V batteries connected in series ($12 = 2 \times 6$). See diagram below. Contact Tripp Lite technical support for assistance with additional parallel, series or series/parallel connections.

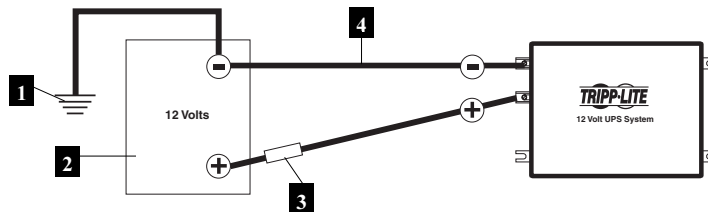

Single Battery Connection

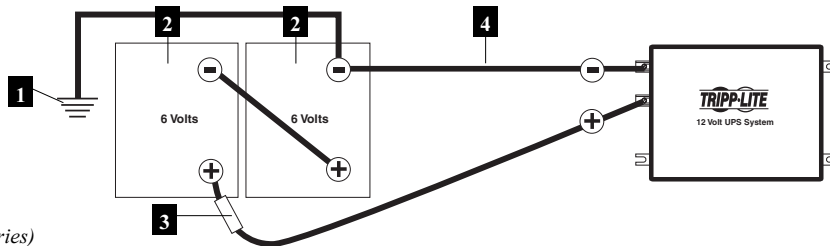

Multiple Battery Connection (Series)

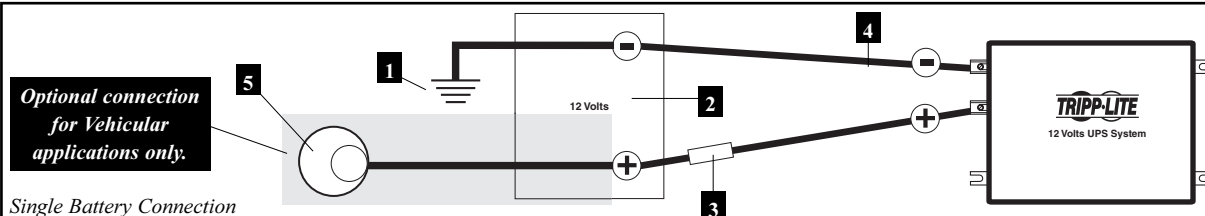

Single Battery Connection

- 1 Earth Ground 2 Battery 3 UL-Listed Fuse & Fuse Block (mounted within 18 inches of the battery) 4 Large Diameter Cabling, Maximum 2/0 Gauge to Fit Terminals 5 Alternator (for vehicle connection only)

AC Input/Output Connection

To avoid overloading your UPS System, match the power requirements of the equipment you plan to run at any one time (add their total watts) with the output wattage capacity of your UPS System model (see Specifications). Do not confuse “continuous” wattage with “peak” wattage ratings. If you are not using your UPS System in conjunction with electronic traffic signal controllers, keep in mind that most electric motors require extra power at start-up (“peak wattage”) than required to run continuously after start-up, sometimes over 100% more. Some motors start and stop intermittently according to demand, requiring “peak wattage” at multiple, unpredictable times during operation. DoubleBoost™ Feature: Tripp Lite UPS Systems deliver up to twice their nameplate rated wattage for up to 10 seconds,* providing the extra power needed to cold start heavy-duty equipment. OverPower™ Feature: Tripp Lite UPS Systems deliver up to 150% of their name-plate rated wattage for up to 1 hour,* providing plenty of reserve power to reliably support equipment longer.

** Actual duration depends on model, battery age, battery charge level and ambient temperature.*

Connection for Models with Cords and Receptacles

Plug the UPS System’s AC input cord into an outlet providing 120V AC, 60Hz. power. Make sure that the circuit you connect your UPS System to has adequate overload protection, such as a circuit breaker or a fuse. Plug your equipment into the UPS System’s AC receptacles. Any equipment you connect to it will benefit from your UPS System’s built-in **ISOBAR**® power conditioning, including surge, spike and lightning protection!



Warning! Consult a qualified electrician and follow all applicable electrical codes and requirements for hardwire connection. Disconnect both DC input and AC utility supply before attempting hardwiring. Use wire type THHN or equivalent with minimum temperature rating of 90°C.

Connection for Models with Hardwire Terminals

Input: Connect incoming wires to the hot (brown) **2**, neutral (blue) **3** and ground* (green) terminals **1**.

Output: Connect outgoing wires to the hot (black) **4**, neutral (white) **5** and ground* (green) terminals **1**.

Replace cover plate and tighten screws. If the incoming conduit only contains two wires (hot and neutral), the incoming conduit must be bonded to the main ground lug on the unit. In any case, the incoming conduit must be bonded to earth ground, and the incoming conduit must be bonded to the outgoing conduit.*

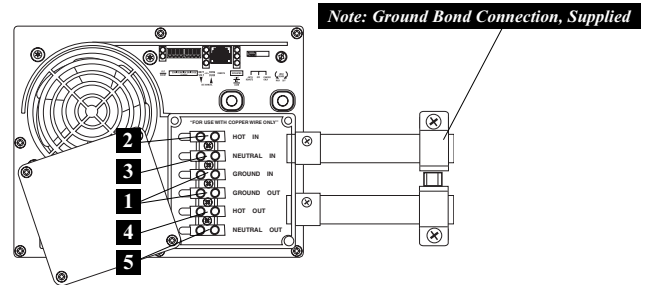

Troubleshooting

Try these remedies for common UPS System problems before calling for assistance. Call Tripp Lite Customer Service at (773) 869-1234 before returning your unit for service.

SYMPTOM	PROBLEMS	CORRECTIONS
No AC Output (All Indicator Lights are OFF)	Unit is not properly connected to utility power	Connect unit to utility power.
	Operating Mode Switch is set to "OFF" and AC input is present.	Set Operating Mode Switch to "AUTO/REMOTE".
	Operating Mode Switch is inadvertently set to "CHARGE ONLY" and AC input is absent.	Set Operating Mode Switch to "AUTO/REMOTE"
	Circuit breaker is tripped.	Reset circuit breaker.
	Unit has shut down due to battery overcharge (preventing battery damage). The problem may be with connected auxiliary chargers, if any, or with the unit's charger.	Disconnect any auxiliary chargers. Reset by moving Operating Mode Switch to "OFF". Wait 1 minute and switch to "AUTO/REMOTE". If unit remains in shutdown mode after several attempts to reset, contact Tripp Lite Customer Service for assistance.
	Unit has shut down due to excessive battery discharge.	Use an auxiliary charger* to raise battery voltage. Check external battery connections and fuse. Unit automatically resets when condition is cleared.
	Connected batteries are dead.	Check and replace old batteries.
Battery Not Recharging (AC Input Present)	Unit has shut down due to overload.	Reduce load. Reset by moving Operating Mode Switch to "OFF". Wait 1 minute. Switch to "AUTO/REMOTE".
	Connected batteries are dead.	Check and replace old batteries.
	Battery fuse* is blown.	Check and replace fuse.*
	Battery cabling* is loose.	Check and tighten or replace cabling.*
	Unit has shut down due to battery overcharge (preventing battery damage). The problem may be with connected auxiliary chargers, if any, or with the unit's charger.	Disconnect any auxiliary chargers. Reset by moving Operating Mode Switch to "OFF". Wait 1 minute and switch to "AUTO/REMOTE". If unit remains in shutdown mode after several attempts to reset, contact Tripp Lite Customer Service for assistance.
	Charger Enable/Inhibit Switch inadvertently set to "INHIBIT"	Set Charger Enable/Inhibit Switch to "ENABLE"
All Three "BATT VOLT/CHRG CURR" LEDs are slowly flashing (½ second flashes) with Operating Mode Switch in the "AUTO/REMOTE" position.	Input circuit breaker is tripped.	Reset circuit breaker.
	Battery is excessively discharged. Unit will shut down to prevent battery damage.	Use an auxiliary charger* to raise battery voltage. Check external battery connections and fuse. Unit automatically resets when condition is cleared.
All Three "BATT VOLT/CHRG CURR" LEDs are rapidly flashing (¼ second flashes) with Operating Mode Switch in the "AUTO/REMOTE" position.	Battery is overcharged. Unit will shut down to prevent battery damage. The problem may be with connected auxiliary chargers, if any, or with the unit's charger.	Disconnect any auxiliary chargers. Reset by moving Operating Mode Switch to "OFF". Wait 1 minute and switch to "AUTO/REMOTE." If unit remains in shutdown mode after several attempts to reset, contact Tripp Lite Customer Service for assistance.
Red "LOW" Battery Indicator Light is flashing with Operating Mode Switch in the "AUTO/REMOTE" position.	Battery voltage is low. Unit has shut down to protect battery from damage.	If AC power (utility- or generator-supplied) is present, the unit will automatically reset itself and start recharging connected batteries. However, if an external charger is used to recharge the batteries, you will need to manually reset the unit by moving the Operating Mode Switch to "OFF" for two seconds then returning it to "AUTO/REMOTE".
	False reading due to undersized or insufficiently connected DC cabling.	Use sufficient size DC cable sufficiently connected to UPS System.
Red "LOAD" Operation Indicator Light flashing	Inverter is overloaded. Unit will automatically shut down after 5 seconds.	Reduce load. Reset by moving Operating Mode Switch to "OFF". Wait 1 minute. Switch to "AUTO/REMOTE".

* User-supplied.

Regulatory Compliance Identification Numbers

For the purpose of regulatory compliance certifications and identification, your Tripp Lite product has been assigned a unique series number. The series number can be found on the product nameplate label, along with all required approval markings and information. When requesting compliance information for this product, always refer to the series number. The series number should not be confused with the marking name or model number of the product.

This product designed and engineered in the USA.