

Sonachron[®] (DWA-S)

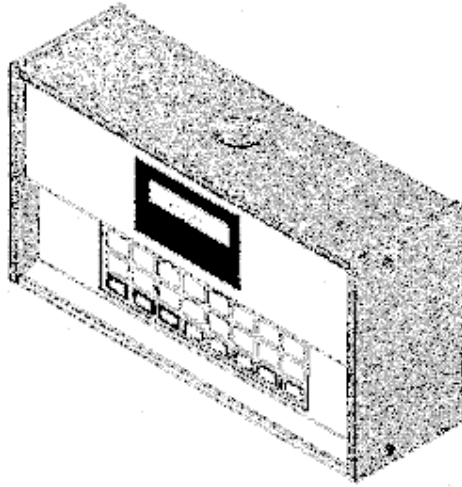

User's Manual



LATHEM TIME

Lathem Time Corporation

200 Selig Drive, SW

Atlanta, GA 30336

1-800-241-4990

1-404-691-0400

www.lathem.com

Document No. OMSC-0708

Copyright © 2008 Lathem Time Corporation.

All rights reserved.

TABLE OF CONTENTS

SPECIFICATIONS.....	1
INTRODUCTION	2
QUICK START STEPS.....	3
DIP SWITCH SETTINGS.....	8
PROGRAMMING A SECURITY CODE	9
UNLOCKING THE KEYPAD.....	10
SETTING TIME AND DATE	10
PROGRAMMING EVENTS (On/Off Controller)	11
PROGRAMMING EVENTS (Bell Ringer).....	12
PROGRAMMING SIGNAL LENGTH (Bell Ringer) ..	12
MANUAL LUNCH AND BREAKS (Bell Ringer)	13
SIGNAL ON/OFF	14
MANUAL OPERATION.....	14
STANDBY POWER	14
RS485 SYNCH	15
WIRING DIAGRAMS	15
WARRANTY	24

SPECIFICATIONS

Input Voltage	115 VAC (220 Optional)
Input Frequency	50/60 Hz
Input Power	20 Watts Max
Standby Power	1.2 Ah, 6 V battery
Standby Time	10 Days
Timing Accuracy	Per line frequency
Number of Events	1440 (any combination of weekdays)
Signal Duration	Programmable – 1 to 99 secs
Daylight Savings	Automatic (Disable by dip switch)
Time Display	12 or 24 hr selectable
Comm Port	RS485 – Receiver
Relays	10 Amp Dry Contact
Temperature Range	0 C to 60 C
Voltage Range	+/- 10 % of input voltage
Shipping Weight	7 lb
Dimensions	9 3/4"x 3 1/4"x 5 3/8"

WARNING: This equipment generates uses and can radiate radio frequency energy and, if not installed and used in accordance with the instruction manual, may cause interference to radio communications. It has been tested and found to comply with the limits for a Class A computing device pursuant to Subpart J of Part 15 of FCC Rules, which are designed to provide reasonable protection against such interference when operated in a commercial environment. Operation of this equipment in a residential area is likely to cause interference, in which case, the user, at his own expense, will be required to take whatever measures may be required to correct the interference.

INTRODUCTION

The DWA-S is a single circuit signaling device which can be used as a bell ringer or on/off controller. It is capable of retaining up to 1440 separate events for each day of the week in memory plus a floating lunch and break schedule which can be activated with a single key on the keypad or a remote switch. Automatic adjustment for daylight savings time change is also provided. A liquid crystal display on the front of the unit displays the current time (in 12 or 24 hour format), date, and day of the week, bell or on/off control status, programming prompts, and indication of operation on standby power. A 24-button keypad is used for setting time, programming events, manual operation of bells or controls, initiating lunch or break bells, and on/off control of the schedule. Access to programming functions and manual keys (MANUAL, START LUNCH, and START BREAK) is controlled by a user defined security code.

The time keeping ability of the DWA-S is dependent on the power source frequency. A switch setting selects operation based on 50 or 60 Hz. During A.C. power failures, the unit switches to a quartz crystal time base and a 6 volt battery allows the unit to continue to keep time and retain all data for 10 days. Upon power resumption, the battery automatically recharges with current limited to 1.5 Amperes.

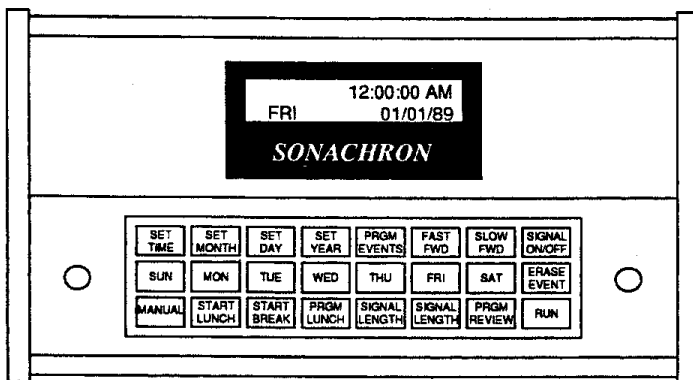

QUICK START STEPS

Step 1 – Mount Unit to Wall

1. Unscrew 2 left screws to remove left side panel.
2. Slide front panel left.

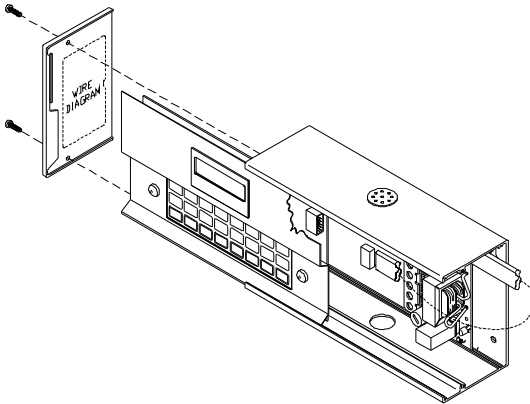

3. Disconnect cable connector from right side of front panel.
4. Slide front panel left and remove completely.
5. Find a suitable location on the wall that allows at least 10 inches of clearance on the left side to allow the front panel to slide on and off.
6. Mark 3 hole positions on wall for mounting the unit.

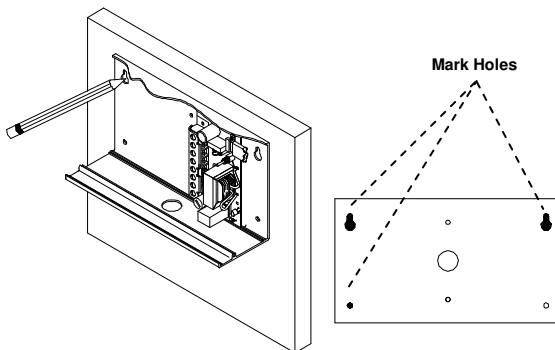

7. Remove plastic bushing from back of unit before mounting on the wall.
8. Drill marked holes and install wall anchors in wall if necessary (not provided).

- Secure unit to wall using screws (not provided).

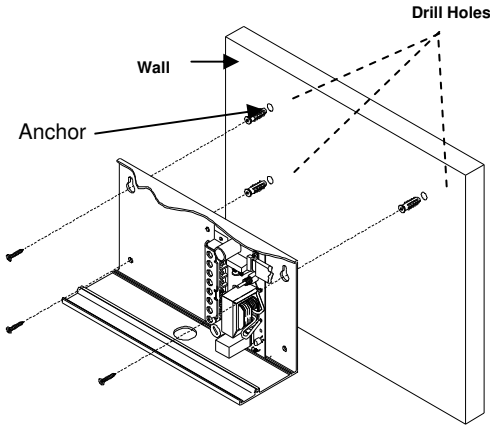

Step 2 – Switch Off Power to AC Circuit

- SWITCH OFF THE CIRCUIT THAT WILL FEED AC POWER TO THE UNIT BEFORE PROCEEDING.

Step 3 – Connect Wires for 115VAC or 24VAC Bells

IMPORTANT! This unit is shipped from the factory as a Bell Ringer. To change to an ON/OFF controller, see DIP Switch Setting on page 8. This section provides instructions for wiring 115VAC or 24VAC bells, see Wiring Diagrams on pages 20 – 22 for other options.

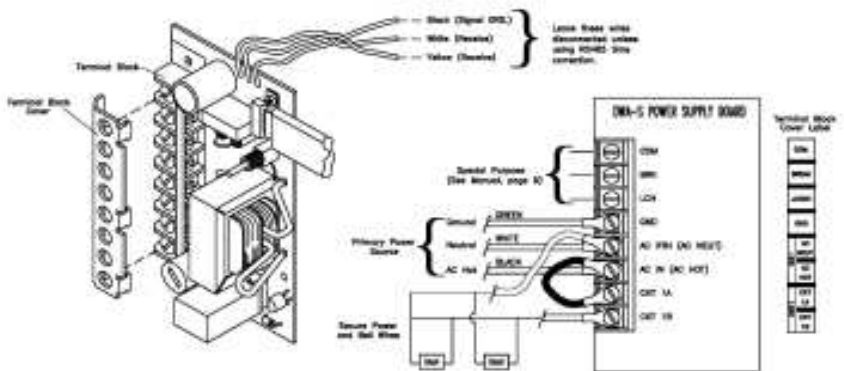

- There are three options for routing wires into the DWA-S: top, back or bottom. Select on of these and remove the plug.
- Remove cover from terminal strip.

IMPORTANT: DO NOT PROCEED IF WIRE COLORS ARE DIFFERENT THAN SHOWN OR IF YOU ARE UNSURE WHICH WIRES ARE AC HOT, AC NEUTRAL AND GROUND. THERE IS RISK OF PERSONAL INJURY AND DAMAGE TO THE UNIT THAT'S NOT COVERED BY WARRANTY. INEXPENSIVE TESTERS ARE AVAILABLE AT YOUR LOCAL HOME ELECTRICAL SUPPLY STORE FOR VERIFYING WIRES.

3. Connect wires from power cord as follows: green (ground) wire to "GND", white (AC neutral) wire to Line Neutral, and black (AC Hot) wire to Line Hot.
4. For 115VAC bells or horns, connect a jumper wire between Line Hot and CKT 1A. Connect the bell wires to AC Neutral and CKT 1B.
5. For 24VAC bells or horns, connect a jumper wire between AC Hot and CKT 1A. Connect the transformer 115VAC/primary wires to AC Neutral and CKT 1B. Connect the transformer 24VAC/secondary wires to the 24 V bells or horns.

NOTE: See pages 20 - 22 for other wiring options that use the COM, BREAK and LUNCH terminals.

Step 4 – Turn on Power Switch

1. Press cover onto Terminal Block.
2. Set Power switch to up position.

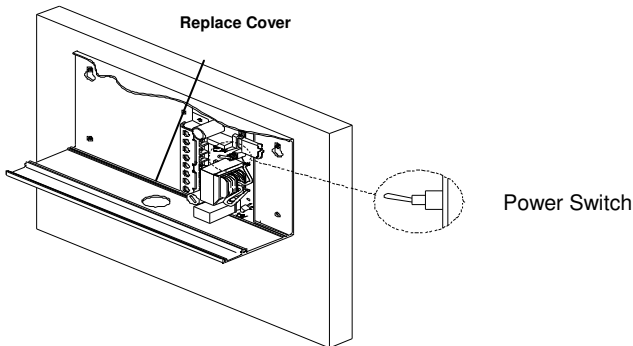

Step 5 – Secure Cover

1. Align front panel in track and slide half way to right.
2. Secure ribbon cable on right edge of front panel.
3. Slide front panel all the way closed making sure that the cable lays down.
4. Attach red battery wire onto battery post.
5. Secure left side panel with the screws.

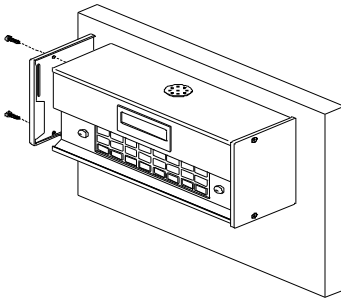
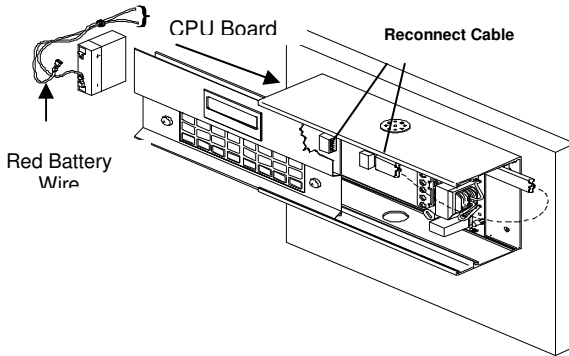

Step 8 – Restore Power to AC Circuit

1. MAKE SURE THE SIDE COVERS ARE SECURE THEN SWITCH ON THE AC POWER TO THE CIRCUIT FEEDING POWER TO THE UNIT.

Step 9 – Test Signaling

1. Your display should appear as shown in the picture below. If not, please contact your dealer or Lathem Time directly.

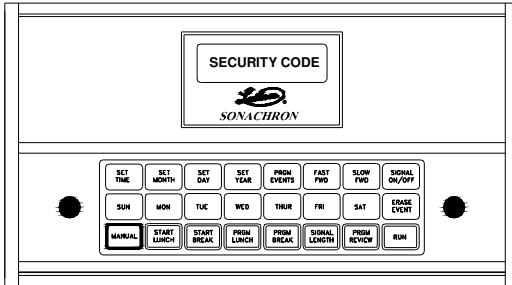

2. Enter a security code using the day of week keys (remember the days that you selected).
3. Press **Run** to return to the normal display showing current time of day.
4. Press the **Manual Bells** button and confirm that the bells and horns are sounding properly. If not, please contact your dealer or Lathem Time directly.

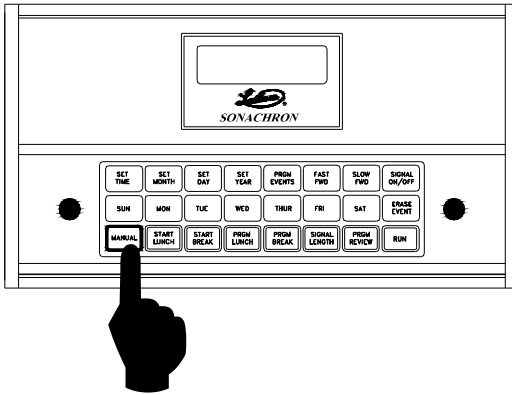

5. Set the time and date, and program the unit as described in the following pages.

DIP SWITCH SETTINGS

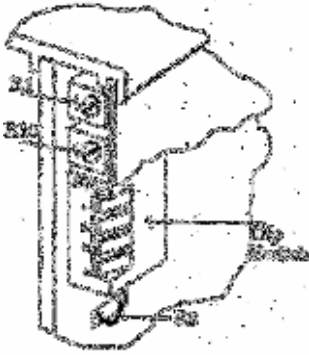

To access the dip switches, remove the two screws holding the left side panel in place and remove the panel. Dip Switches 1, 2, and 3 are monitored at all times and changes take effect immediately. Dip Switch 4 is read only at power up. To change the setting for this switch, the unit must be powered completely off and back on. Dip Switch 2 is also used to reset the security code. Any change in its setting will allow you to view and change the security code. The unit is shipped from the factory with all dip switches in the ON position. The chart below shows the dip switch settings:

Dip Switch	Description	ON	OFF
1	Time Keeping Frequency	60 Hz	50 Hz
2	Time Format (Security Code Access)	12 Hr	24 Hr
3	Daylight Savings Time Change	Enabled	Disabled
4	Operation	Bell Ringer	On/Off Controller

PROGRAMMING A SECURITY CODE

Upon power up you are allowed to enter a security code to restrict access to programming functions. When the unit displays "**SECURITY CODE**", press from one to four Day of the Week keys. This is your security code. The **ERASE EVENT** key can be used to clear the code for re-entry. Press the **RUN** key to advance the programming when you are satisfied with the security code. The unit will prompt "**UNSECURED MANUAL FWD TO CHANGE.**" If this selection is chosen, only the programming functions will require the security code to be accessed. **MANUAL, START LUNCH, and START BREAK** will be unsecured. Pressing the selection requires the security code to be entered prior to both accessing the programming functions and using the **MANUAL, START LUNCH, and START BREAKS** keys. The remote **START LUNCH** and **START BREAK** switches do not require the security code to activate Lunch or Break schedules. After choosing the level of security desired, press the **RUN** key to advance to the normal display.

If unlimited access to all functions is desired (no security), press the **RUN** key without pressing any Day of the Week keys when the unit prompts for the security code. The unit will advance to the normal display and no security code will be required to access any function.

To change or view the security code, remove the left side panel, toggle Dip Switch 2, and return it to the desired position. The current security code will be displayed. Replace the side panel. To change the code, press the **ERASE EVENT** key to clear the current code and program the new code in the same manner as described above. If you do not wish to change the code, press the **RUN** key until the normal display returns.

UNLOCKING THE KEYPAD

To unlock the keypad, press the Day of the Week keys you programmed for the security code followed by **RUN**. The security keys must be pressed in the exact order as they were originally entered. The display should read "**SELECT FUNCTION.**" To relock the keypad, simply press **RUN**. The keypad must be unlocked, or no security programmed, to access programming functions. Remote operation of Start Lunch or Start Break switches do not depend on the status of the keypad or security code. Pressing the **MANUAL, START LUNCH,** or **START BREAK** key while in the programming mode (keypad unlocked) will ring the bells and return the unit to the normal display with the keypad secured. The **PRGM LUNCH, PRGM BREAK, SIGNAL LENGTH,** and **PRGM REVIEW** keys may be pressed while the keypad is locked to view the current settings of their respective functions.

SETTING TIME AND DATE

Follow procedure above to unlock keypad. The display should read "**SELECT FUNCTION.**" To set the time, simply press the **SET TIME** key and use the **FAST FWD** and **SLOW FWD** keys to advance to the correct time. The seconds will be set to zero when either forward key is pressed. Selecting another function or pressing **RUN** will start the seconds indexing. To set the month, date, or year, press the **SET MONTH, SET DAY,** or **SET YEAR** key, respectively. Use the forward keys to advance to the appropriate setting. Continue to next programming procedure or press **RUN** to return to the normal display. The day of the week will be determined automatically based on the date.

PROGRAMMING EVENTS (On/Off Controller)

NOTE: Dip Switch 4 must be set to **OFF** (see page 8)

With “**SELECT FUNCTION**” displayed, press the **PRGM EVENTS** key. The display should read “**CONTROL 12:00 AM.**” Use the **FAST FWD** and **SLOW FWD** keys to advance the displayed time to the desired event time. Once the event time is reached, press the day of the week keys (**Sun, Mon, Tue**, etc.) to indicate on which day(s) the control should operate. Pressing a key once will display the day of the week and pressing it again will remove it. The control will default to OFF, press the **SIGNAL ON/OFF** key to toggle the control between OFF and ON. Once you have chosen the day(s) and on/off status for the event, use the forward keys to advance the time to the next event and enter the day(s) and On/Off status. Continue in this fashion until all controls are programmed. Press **RUN** to lock the keypad and return to the normal display.

While in the Program Events function, the **PRGM REVIEW** and **ERASE EVENT** keys can be used to scan and erase events, respectively. To scan programmed events, simply press the **PRGM REVIEW** key. The next event in memory will be located and displayed. Pressing the key repeatedly will scan through all events sequentially. To erase an event, locate the event and press the **ERASE EVENT** key.

PRGM REVIEW may also be used when the keypad is locked. Pressing the key will display the next scheduled event. Press the key repeatedly to scan all programmed events. The normal display will return after 5 seconds or when the **RUN** key is pressed. **ALL LUNCH** and **BREAK** keys and remote switches are inactive when using the unit as an On/Off Controller.

PROGRAMMING EVENTS (Bell Ringer)

NOTE: Dip Switch 4 must be set to **ON** (see page 8)

With “**SELECT FUNCTION**” displayed, press the **PRGM EVENTS** key. The display should read “**SIGNAL 12:00 AM**” “**ON DAYS:**” Use the **FAST FWD** and **SLOW FWD** keys to advance the displayed time to the desired event time. Once the event time is reached, press the day of the week keys (**Sun, Mon, Tue**, etc.) to indicate on which day(s) the bells should ring. Pressing a key once will display the day of the week and pressing it again will remove it. Once you have chosen the day(s) for the event, use the forward keys to advance the time to the next event and enter the days. Continue in this fashion until all events are programmed. Press **RUN** to lock the keypad and return to the normal display.

While in the Program Events function, the **PRGM REVIEW** and **ERASE EVENT** keys can be used to scan and erase events, respectively. To scan programmed events, simply press the **PRGM REVIEW** key. The next event in memory will be located and displayed. Pressing the key repeatedly will scan through all events sequentially. To erase an event, locate the event and press the **ERASE EVENT** key.

PRGM REVIEW may also be used when the keypad is locked. Pressing the key will display the next scheduled event. Press the key repeatedly to scan all programmed events. The normal display will return after 5 seconds or when the **RUN** key is pressed.

PROGRAMMING SIGNAL LENGTH (Bell Ringer)

The signal length defaults to 5 seconds. To change this value, unlock the keypad and press the **SIGNAL LENGTH** key. The current signal length will be displayed. Use the **FAST FWD** and **SLOW FWD** keys to change the setting. Values from 1 to 99 seconds are allowed. Press **RUN** to return to the normal display.

To review the signal length without unlocking the keypad, simply press the **SIGNAL LENGTH** key. The normal display will return after 5 seconds or when the **RUN** key is pressed.

MANUAL LUNCH AND BREAKS (Bell Ringer)

This function provides a means of programming set lunch and break lengths which can be initiated at various times during the day. It is only available when the unit is used as a Bell Ringer and operating on AC power. Pressing the **START LUNCH** or **START BREAK** key at the keypad (or a remote momentary switch connected to the unit) causes the bells to signal and a displayed timer to begin counting down the programmed lunch or break time. When the timer counts to zero, the bells automatically signal again to indicate the end of lunch or break. This feature is especially convenient for facilities which are serviced by a lunch truck. When the truck arrives on site, simply press the remote lunch switch to begin the lunch break. This function also allows a warning bell to ring before the final lunch or break bell.

To program a lunch, unlock the keypad then press the **PRGM LUNCH** key. Use the forward keys to program the desired lunch length, 00 to 99 minutes. Press the **PRGM LUNCH** key a second time to display the length of time (0 to 9 minutes) a warning bell will ring before the ending bell rings. The default is 0. Use the forward keys to change this value. Press the **RUN** key to return to the normal display. Program breaks in the same method.

Scheduled bells are inhibited during lunch and break periods. If the schedule is turned off or the **MANUAL** key pressed while a lunch or break period is in progress, the remaining lunch or break time will be canceled. If the wrong key was pressed, **LUNCH** instead of **BREAK** or **BREAK** instead of **LUNCH**, simply press the correct key before the programmed time has expired. The bells will not ring again and the time already elapsed will be applied towards the programmed time for the break or lunch. To review the programmed times without unlocking the keypad, simply press the **PRGM LUNCH** or **PRGM BREAK** key. The normal display will return after 5 seconds or when the **RUN** key is pressed.

SIGNAL ON/OFF

Pressing the **SIGNAL ON/OFF** key when the keypad is unlocked changes the On/Off status of the programmed schedule. When the status is ON, bells or controls will operate based on the schedule. When the status is OFF, the schedule is ignored and only the manual key will operate the bells or controls. The current On/Off status of controls will remain active until **MANUAL** is pressed or the schedule reactivated. Press **RUN** to return to the normal display. When the schedule is inactive, **SCHEDULE OFF** will be shown below the time on the display.

MANUAL OPERATION

Pressing the **MANUAL** key when the unit is being used as a Bell Ringer will cause the bells to signal for the length of time the key is pressed. This provides a means of operating the bells at unscheduled times. Pressing **MANUAL** while lunch or break is counting down will operate the bells and cause the remaining lunch or break time to be canceled.

Pressing the **MANUAL** key when the unit is operating as an On/Off Controller will toggle the current On/Off status of the controls.

The **MANUAL** key will not ring bells if the unit is operating on standby power.

STANDBY POWER

During AC power failures, the DWA-S switches to a quartz crystal time base to maintain the time keeping ability of the unit. A 6 volt battery allows the unit to continue operation and retain the programmed schedule for 10 days. An * on the lower line of the display indicates operation on Standby Power.

Programming, schedule review, and manual toggling of the On/Off control status are available when operating on battery back up. If operating as a Bell Ringer, the **MANUAL**, **START LUNCH**, and **START BREAK** keys, and the remote **START LUNCH** and **START BREAK** switches are inactive during AC power failures. Schedule operation is also inactive when operating as a Bell Ringer.

RS485

The DWA-S comes equipped with an RS485 receiver which can be used to synchronize the time and date of the unit with other equipment. The option supplies three leads on the power supply board for connecting to the sending device. The interconnection cable between devices should be a minimum of 3 meters long to prevent interference to radio communications as required by FCC regulations. Cables less than 3 meters in length require a Fair-Rite bead (Lathem Part # VII0058) installed around the cable. The figure below indicates the signal names and corresponding wire colors.

Signal	Wire Color
Receive (+)	White
Receive (-)	Yellow
Signal Ground	Black

NOTE: Preferred cable is CAT-3 or CAT-5 twisted-pair, up to 4,000 feet in length.

WIRING DIAGRAMS

FIGURE 1: CONNECTION FOR DWA-S TO LTRX-512

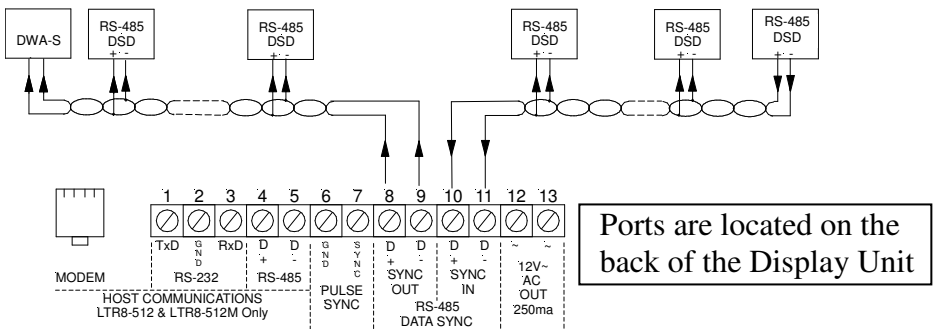

NOTE: Since the Sync In port can send as well as receive, 30 extra devices can connect here. If you already have a Master Source, such as an LTR-0, connect it and its string of clocks to the Sync In port, for a total of up to 60 devices.

FIGURE 2: CONNECTION FOR DWA-S TO LTR-0

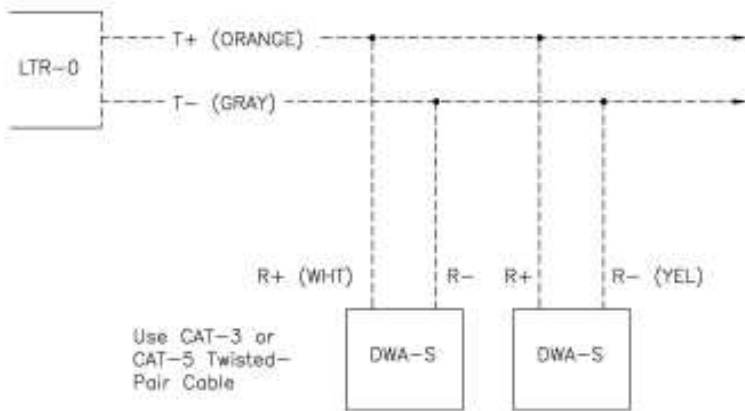

FIGURE 3: CONNECTION FOR DWA-S TO LTR-GPS

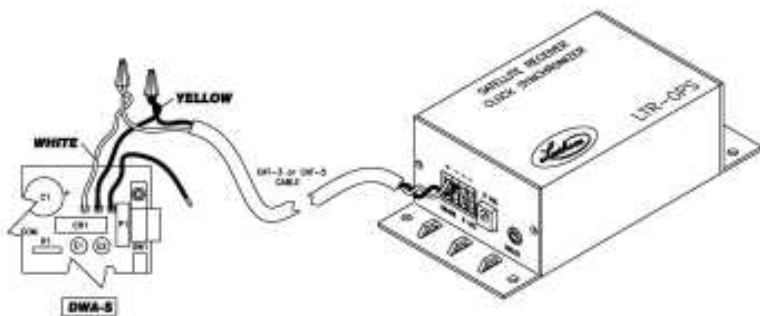
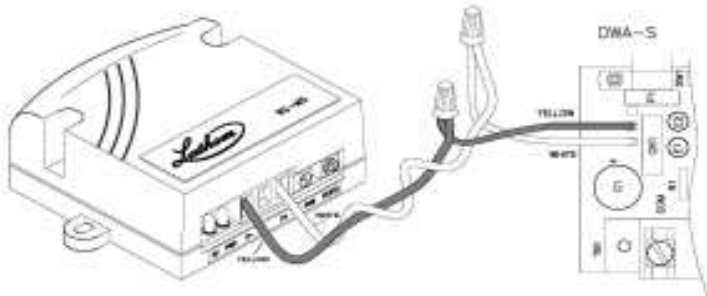

FIGURE 4: CONNECTING RC-MS TO SYNCH DWA-S OR LTR-0



NOTE: A 9vDC Power Adapter (not shown) is also required for the RC-MS.

FIGURE 5: OMC – DWA-S INTERCONNECTION

OMC-DWA-S INTERCONNECTION

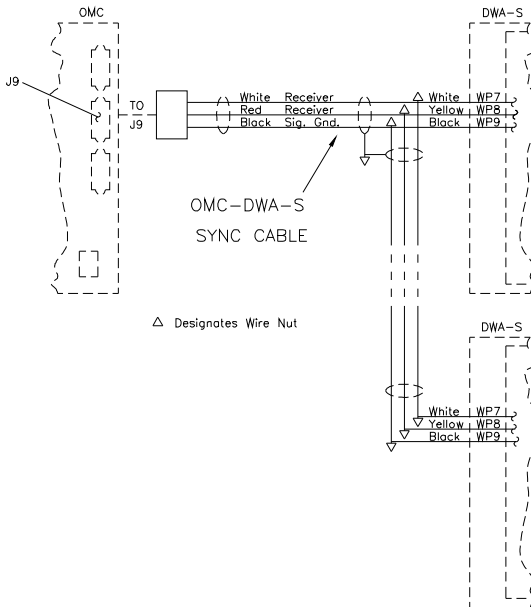

Sonachron (DWA-S) can be synchronized to Lathem's LTRx-512 master, LTR-0 master, LTR-GPS receiver, RC-MS master or Omni:ChronII time clock reference devices. Distance from the source can be extended using Lathem's SWIFT485+ repeater.

Omni:ChronII Time Recorder can be equipped with an optional RS485 transmitter for communication with the DWA-S. When installed, the DWA-S will synchronize with the time and date from the Omni:ChronII each minute.

When installing multiple DWA-S units, all units EXCEPT the one at the end of the RS485 line require jumper E2 be cut. When E2 is installed, a 100 ohm terminating resistor is internally connected across the RS485 line to reduce the signal reflection and thereby improve reception. E2, located on the far left side of the CPU circuit board, can be accessed by removing the left end cap. Refer to the Figure on Page 8.

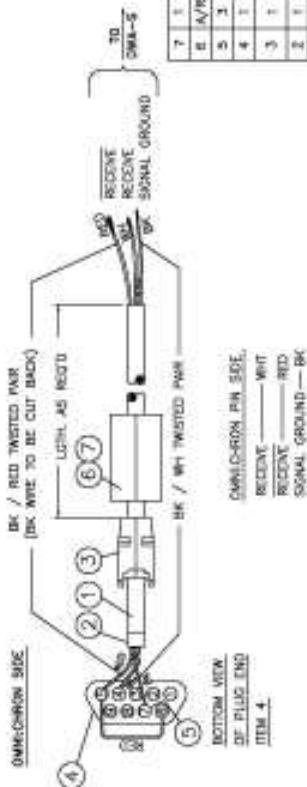

SAE-0038

OS-9P

ITEM QTY	PART NO.	MFG'S NO.	DESCRIPTION	MFG#	
7	1	MS-0760	#2199164251	PLASTIC HOUSING	FAR-RITE
8	A/R	VI-0058	#2643164251	BEAD	FAR-RITE
5	3	VE-0392	#1-86508-0	CRIMP TYPE CONTACT, PIN	AMP
4	1	VE-0285	#205204-3	9 PIN CONNECTOR (9-PIN) PLUG	AMP
3	1	VE-0388	#749054-3	9/16" DIA METALIZED SHIELD FOR JACKETS CABLE	AMP
2	1	VE-0387	#745508-3	SPLIT RING FERRULE	AMP
1	1			CABLE 2' W/ 24 AWG X 1 L. COND. W/ BRAIDED SHIELD	ACCU-TECH

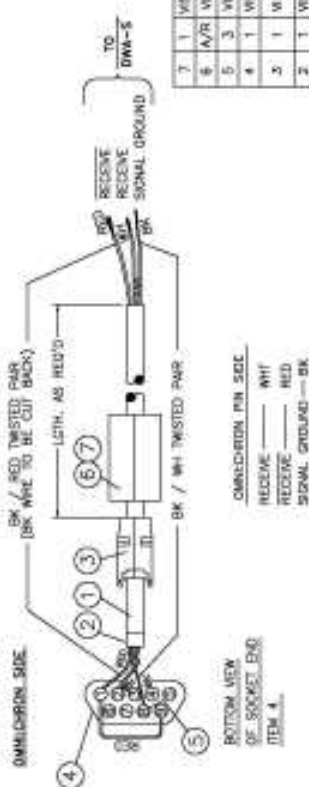

SAE-0045

NS-9S

ITEM QTY	PART NO.	MFG'S NO.	DESCRIPTION	MFG#	
7	1	MS-0760	#2199164251	PLASTIC HOUSING	FAR-RITE
8	A/R	VI-0058	#2643164251	BEAD	FAR-RITE
5	3	VE-0391	#1-66504-0	CRIMP TYPE CONTACT, SOCKET	AMP
4	1	VE-0392	#205203-3	9 PIN CONNECTOR (9-PIN) SOCKET	AMP
3	1	VE-0288	#745504-3	9/16" DIA METALIZED SHIELD FOR JACKETS CABLE	AMP
2	1	VE-0387	#745508-3	SPLIT RING FERRULE	AMP
1	1			CABLE 2' W/ 24 AWG X 1 L. COND. W/ BRAIDED SHIELD	ACCU-TECH

(INC TO DWA-S)

NOTE:
The interconnection cable between devices should be a minimum of 9 feet (3 Meters) long, to prevent interference to radio communications as required by FCC regulations. Cable less than 9 Feet (3 Meters) in length, requires a 5/8"-dia ball (ITEM 6) terminated ground cable.

FIGURE 6: 115/220 VAC BELL WIRING

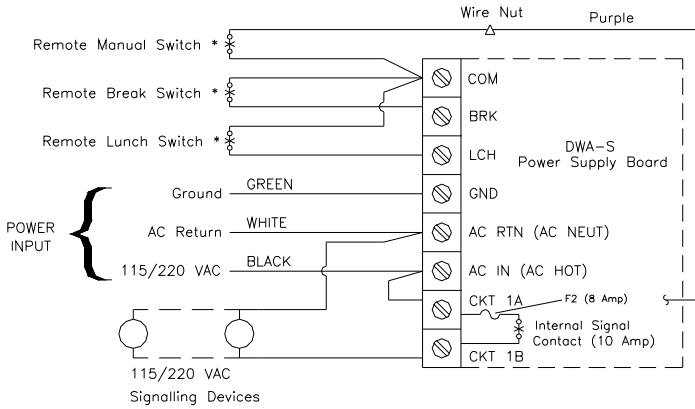

FIGURE 7: LOW VOLTAGE AC BELL WIRING

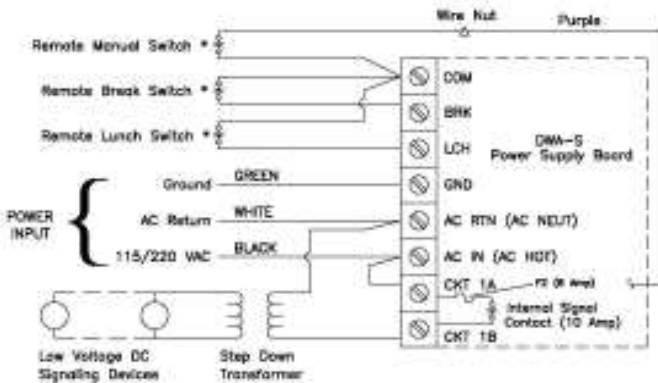

FIGURE 8: LOW VOLTAGE DC BELL WIRING

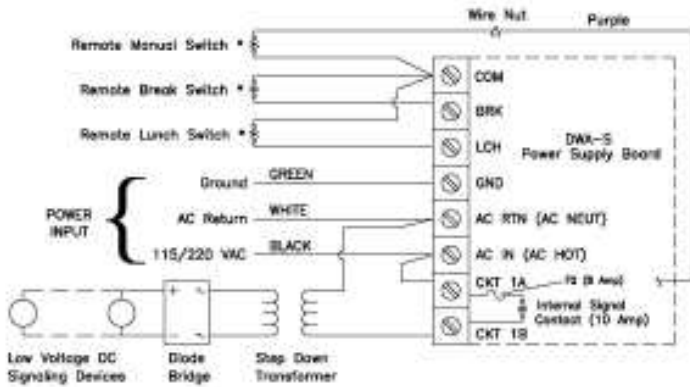

FIGURE 9: 115/220 VAC CONTROL WIRING

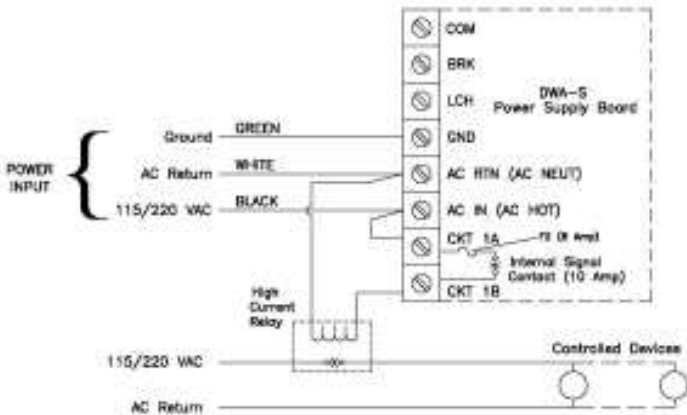

FIGURE 10: LOW VOLTAGE AC CONTROL WIRING

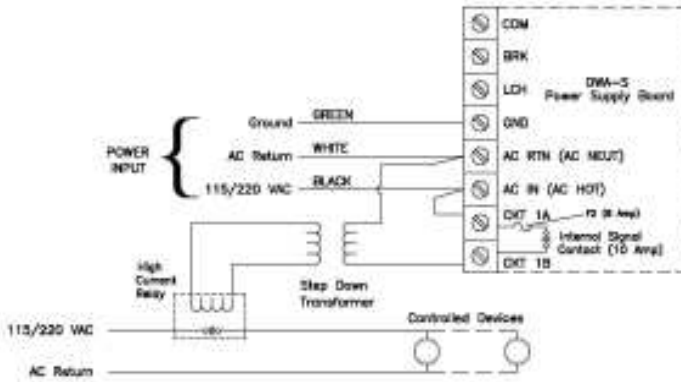

FIGURE 11: LOW VOLTAGE DC CONTROL WIRING

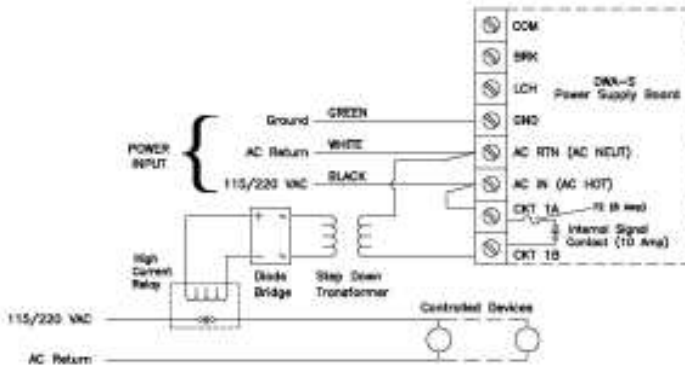
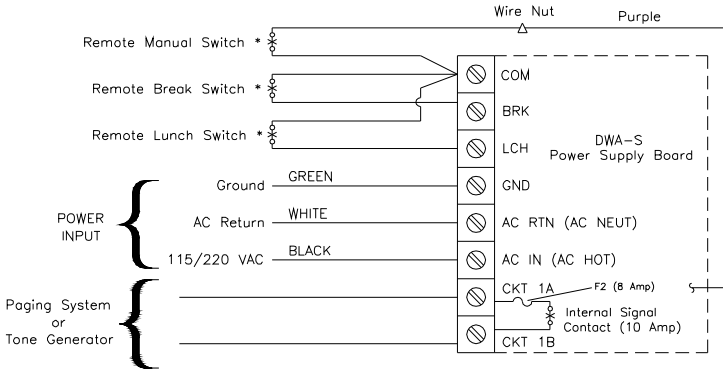

FIGURE 12: DRY CONTACT WIRING FOR PAGING SYSTEM OR TONE GENERATOR



Limited One-Year Limited Warranty

Lathem warrants the hardware products described in this guide against defects in material and workmanship for a period of **one year** from date of original purchase from Lathem or from an authorized Lathem reseller. The conditions of this warranty and the extent of the responsibility of Lathem Time Corporation ("Lathem") under this warranty are listed below.

1. This warranty will become void when service performed by anyone other than an approved Lathem warranty service dealer results in damage to the product.
2. This warranty does not apply to any product which has been subject to abuse, neglect, or accident, or which has had the serial number altered or removed, or which has been connected, installed, adjusted, or repaired other than in accordance with instructions furnished by Lathem.
3. This warranty does not cover dealer labor cost for removing and reinstalling the machine for repair, or any expendable parts that are readily replaced due to normal use.
4. The sole responsibility of Lathem under this warranty shall be limited to repair of this product, or replacement thereof, at the sole discretion of Lathem.
5. If it becomes necessary to send the product or any defective part to Lathem or any authorized service dealer, the product must be shipped in its original carton or equivalent, fully insured with shipping charges prepaid. Lathem will not assume any responsibility for any loss or damage incurred in shipping.
6. **WARRANTY DISCLAIMER AND LIMITATION OF LIABILITY:** Except only the limited express warranty set forth above, the products are sold with no expressed or implied warranties of any kind, and the implied warranties of merchantability and fitness for a particular purpose are hereby expressly disclaimed. No warranties are given with respect to products purchased other than from Lathem or an authorized Lathem reseller and any such products are purchased "as is, with all faults." In no event will Lathem be liable for any direct, indirect, special, incidental or consequential damages arising out of or in connection with the delivery, use or inability to use, or performance of this product. In the event any limited remedy given herein shall be deemed to have failed of its essential purpose, Lathem's maximum liability shall be to refund the purchase price upon return of the product.
7. Proof of date of purchase from Lathem or an authorized Lathem reseller is required for warranty service on this product.
8. This Warranty grants specific legal rights. Additional legal rights, which may vary by locale, may also apply.
9. Should any difficulties arise with the performance of this product during warranty, or with any Lathem authorized service centers, contact Lathem Time at the address below.

Lathem Time
200 Selig Drive, SW, Atlanta, GA 30336
1-404-691-0405
www.lathem.com

