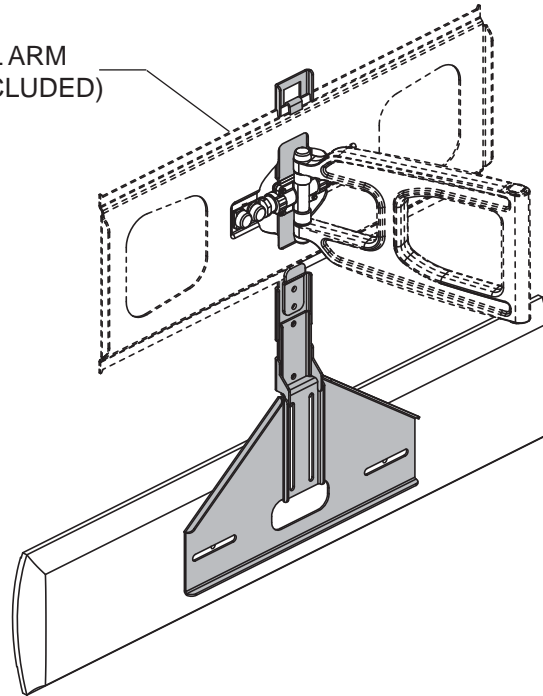


## Installation and Assembly: Speaker Bracket

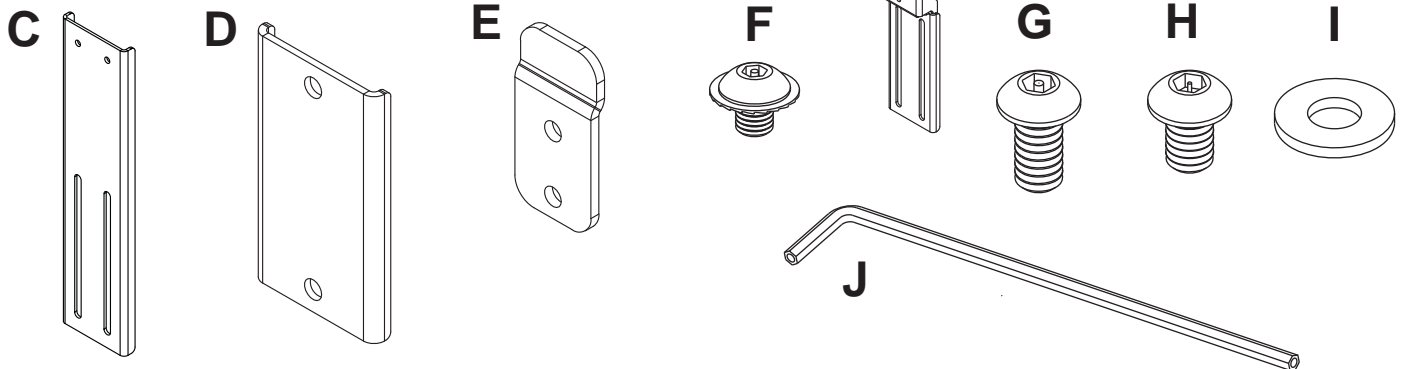
Model: ACC-SB, ACC-SB-M

WALL ARM  
(NOT INCLUDED)

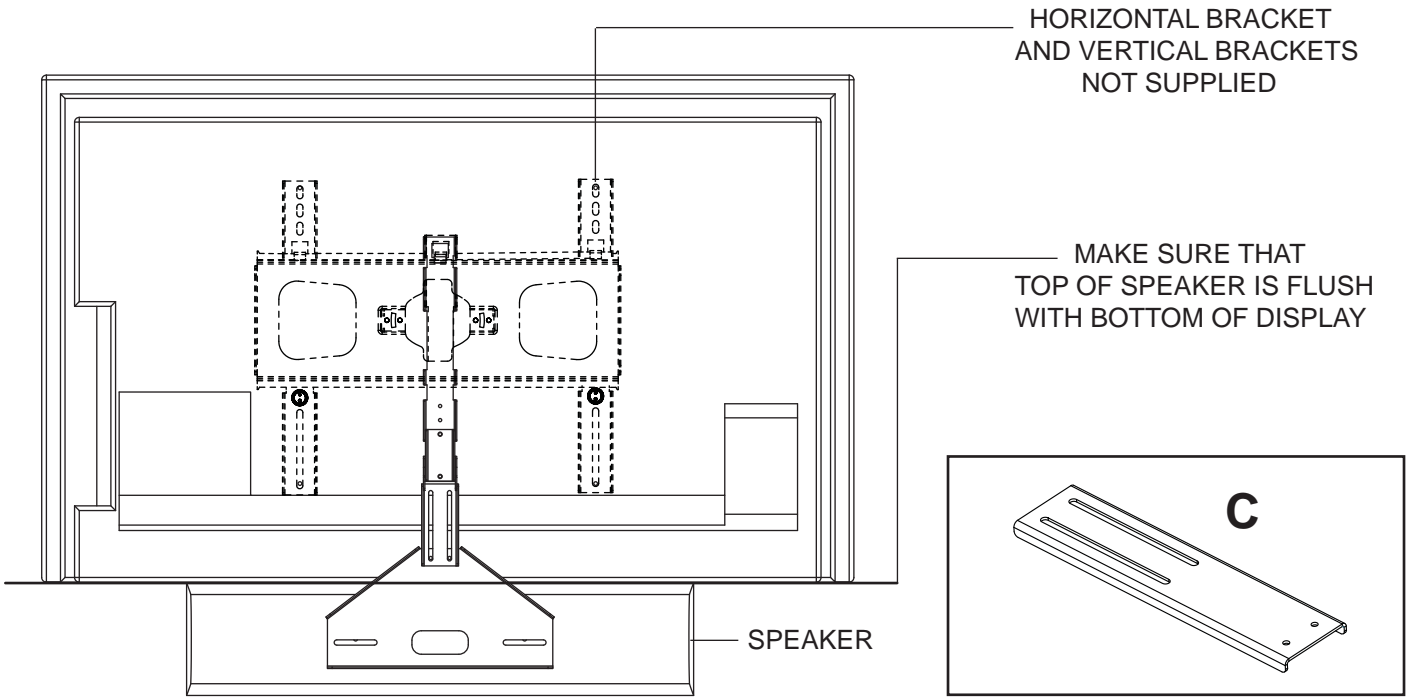


### Parts List

Description	Qty.	Part #
A hook on bracket	1	046-P1218
B speaker bracket	1	046-P1222
C extension bracket	1	046-P1221
D reinforcement bracket	1	046-P1220
E lock bracket	1	046-P1219
F M5 x 6 mm socket pin serrated washer head screw	8	510-1114
G 1/4-20 x 1/2" socket pin screw	2	520-1054
H 1/4-20 x 3/8" socket pin screw	2	520-1109
I 1/4" flat washer	2	540-9440
J 4 mm allen wrench	1	560-9646

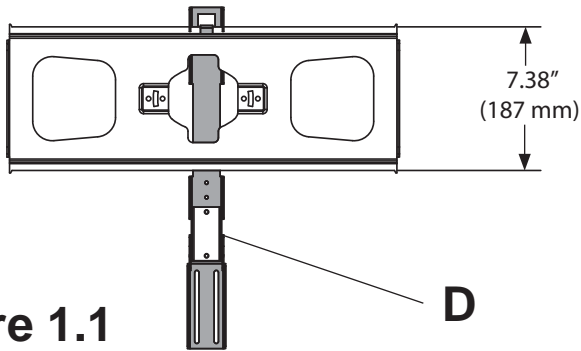


- 1** Lay display face down on a nonabrasive surface. Use detail below to determine if extension bracket (C) is needed.  
**NOTE:** Top of speaker must extend below the bottom of the screen.  
 If extension bracket (C) is not needed skip to step 2 on page 3.  
 If extension bracket (C) is needed skip to step 2 on page 5.



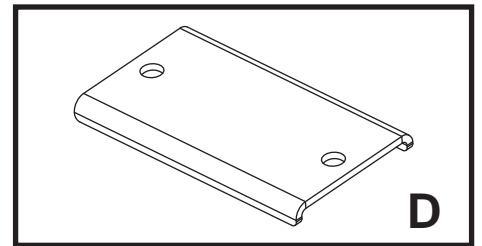
- 1** Use figures 1.1 and 1.2 to determine if reinforcement bracket (D) is needed.  
 If reinforcement bracket (D) is needed skip to step 2 on page 3.  
 If reinforcement bracket (D) is not needed skip to step 2 on page 5.

**SUA745PU, SUA745PU-M**

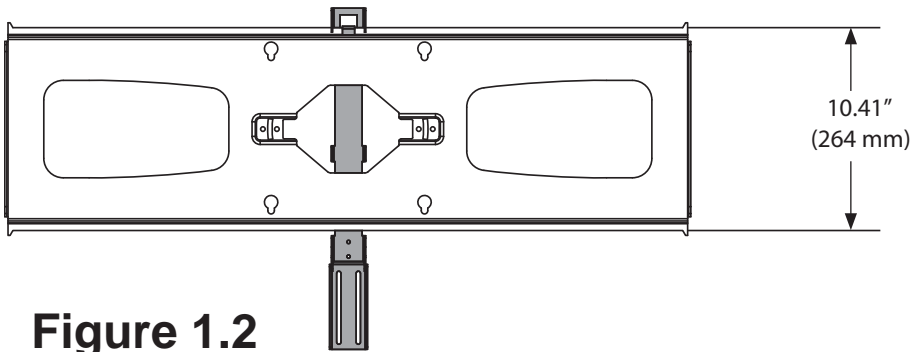


**Figure 1.1**

**Will Use Reinforcement Bracket**

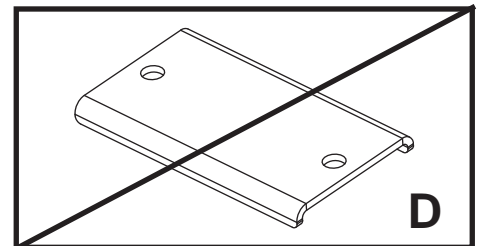


**SUA750PU, SUA750PU-M, SUA765PU**



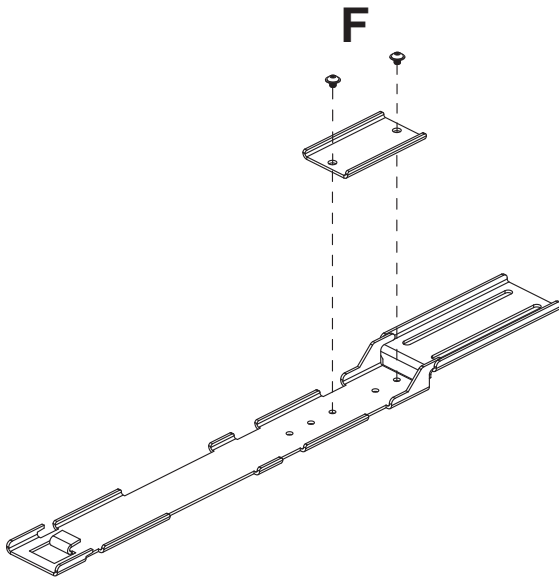
**Figure 1.2**

**Will Not Use Reinforcement Bracket**

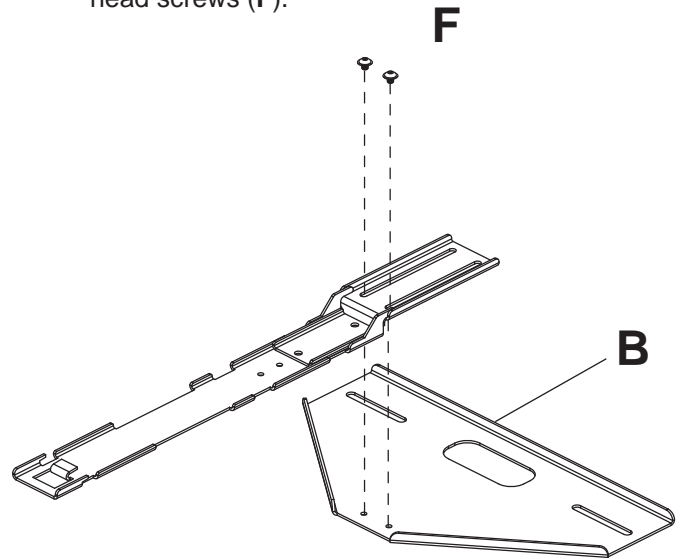


## Attaching Reinforcement Bracket and Speaker Bracket

- 2 Attach reinforcement bracket (D) to adapter bracket (A) using two M5 x 6 mm socket pin serrated washer head screws (F).

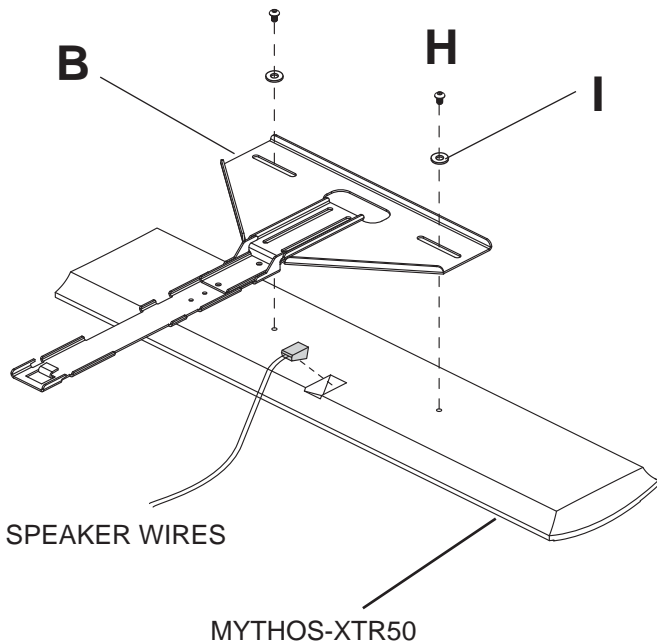


- 3 Attach adapter bracket (A) to speaker bracket (B) using two M5 x 6 mm socket pin serrated washer head screws (F).

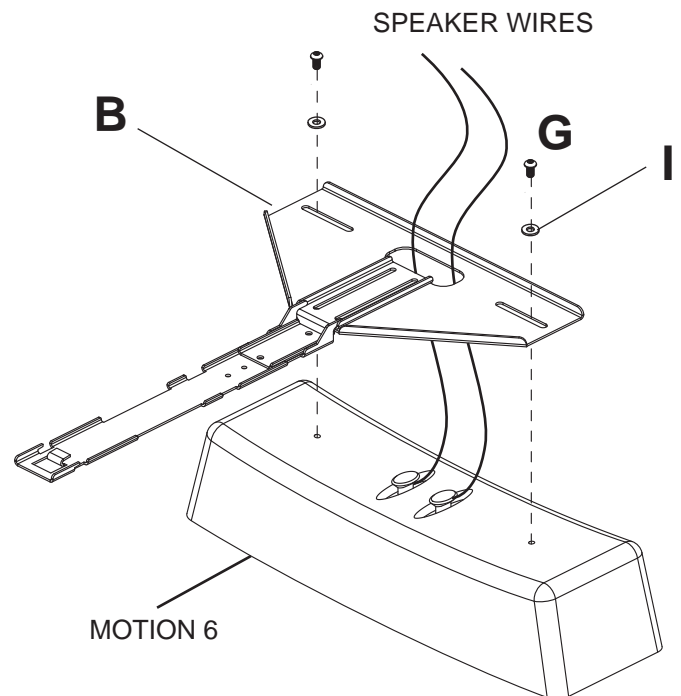


## Attaching Speaker

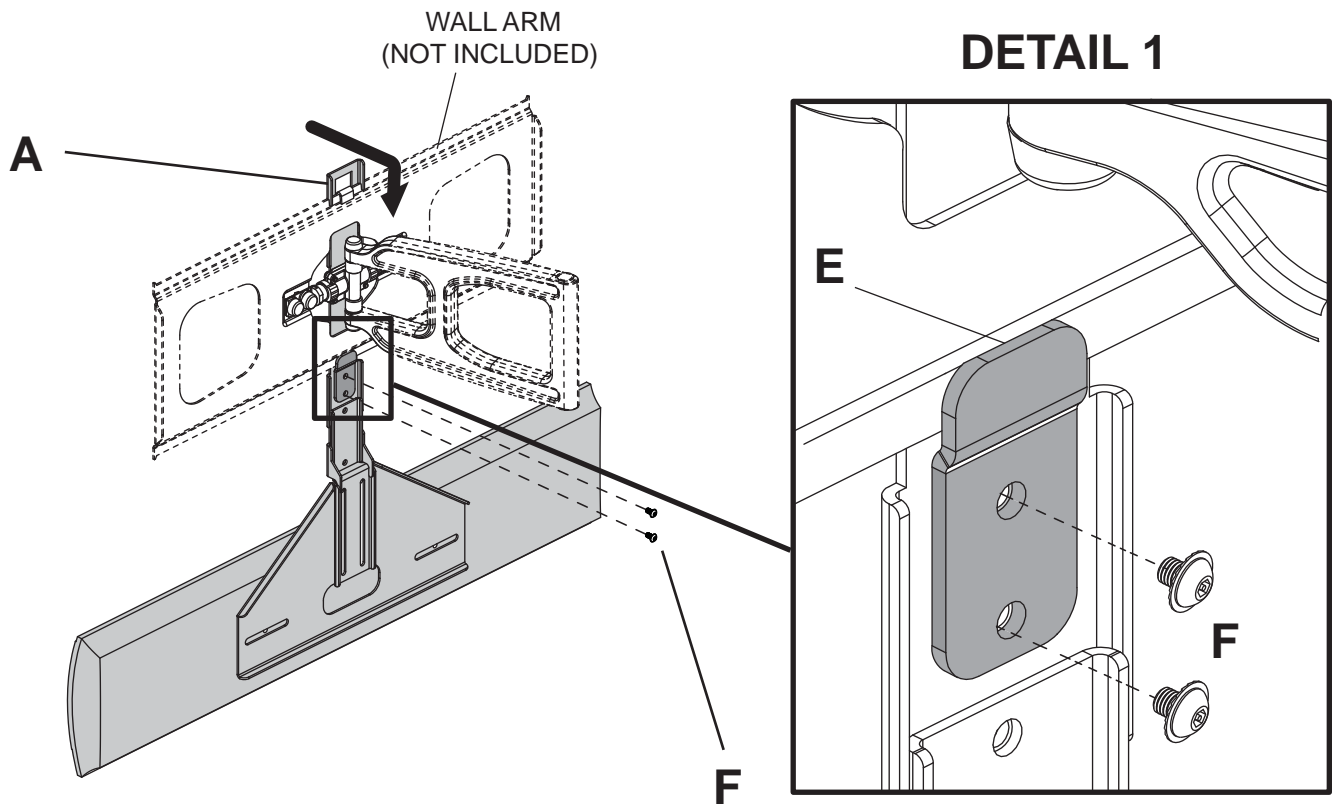
- 4 **NOTE:** Make sure that speaker wires are connected as indicated in speaker instructions before attaching speaker bracket (B). Secure speaker bracket (B) to speaker using two 1/4-20 x 3/8" socket pin screw (H), and two 1/4 flat washers (I).



- 4 **NOTE:** Make sure that speaker wires are connected as indicated in speaker instructions before attaching speaker bracket (B). Secure speaker bracket (B) to speaker using two 1/4-20 x 1/2" socket pin screw (G), and two 1/4 flat washers (I).

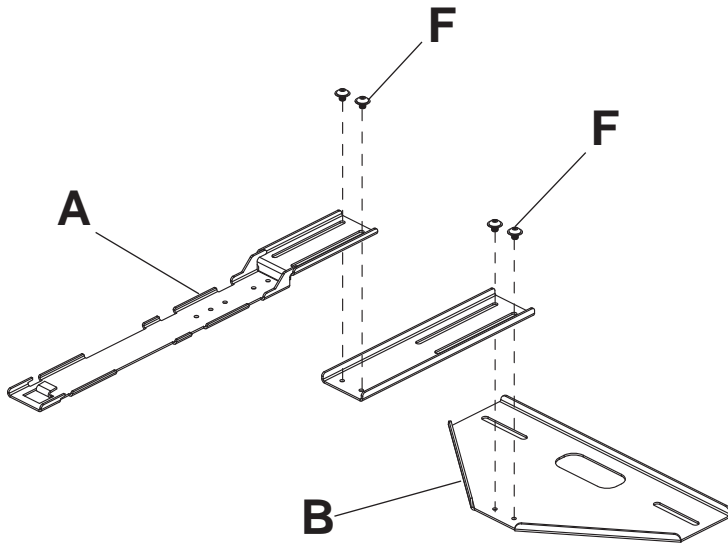


- 5 Hook adapter bracket (A) onto wall arm (not included) and secure using lock bracket (E) and two M5 x 6 mm socket pin serrated washer head screws (F) as shown in detail 1.

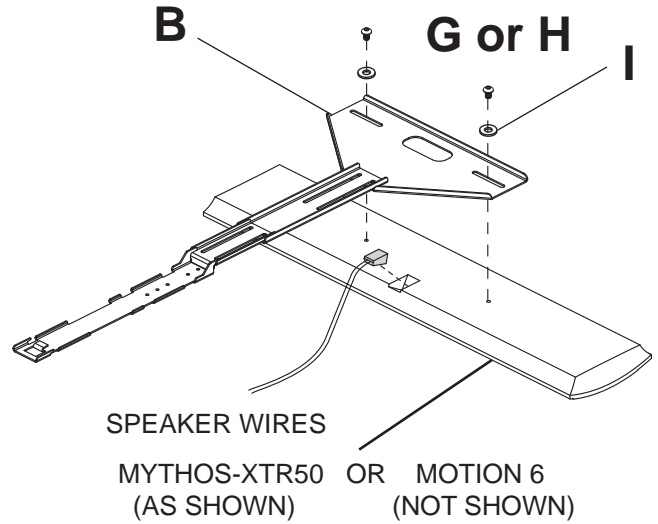


# Attaching Speaker Using Extension Bracket

**2** Attach adapter bracket (A) to extension bracket (C) and speaker bracket (B) using two M5 x 6 mm socket pin serrated washer head screws (F) as shown below.



**3** **NOTE:** Make sure that speaker wires are connected as indicated in speaker instructions before attaching speaker bracket (B). Secure speaker bracket (B) to speaker using two 1/4-20 socket pin screws (G or H), and two 1/4 flat washers (I).



**4** Hook adapter bracket (A) onto wall arm (not included) and secure using lock bracket (E) and two M5 x 6 mm socket pin serrated washer head screws (F) as shown in detail 2.

