

# WESLO<sup>®</sup>

## 225 GTX

Model No. WLTL19507.0

Serial No. \_\_\_\_\_

Write the serial number in the space above for future reference.

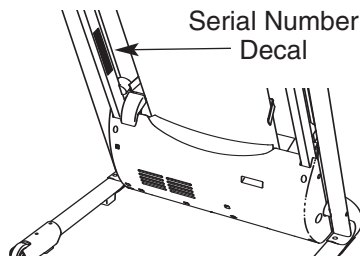

## USER'S MANUAL

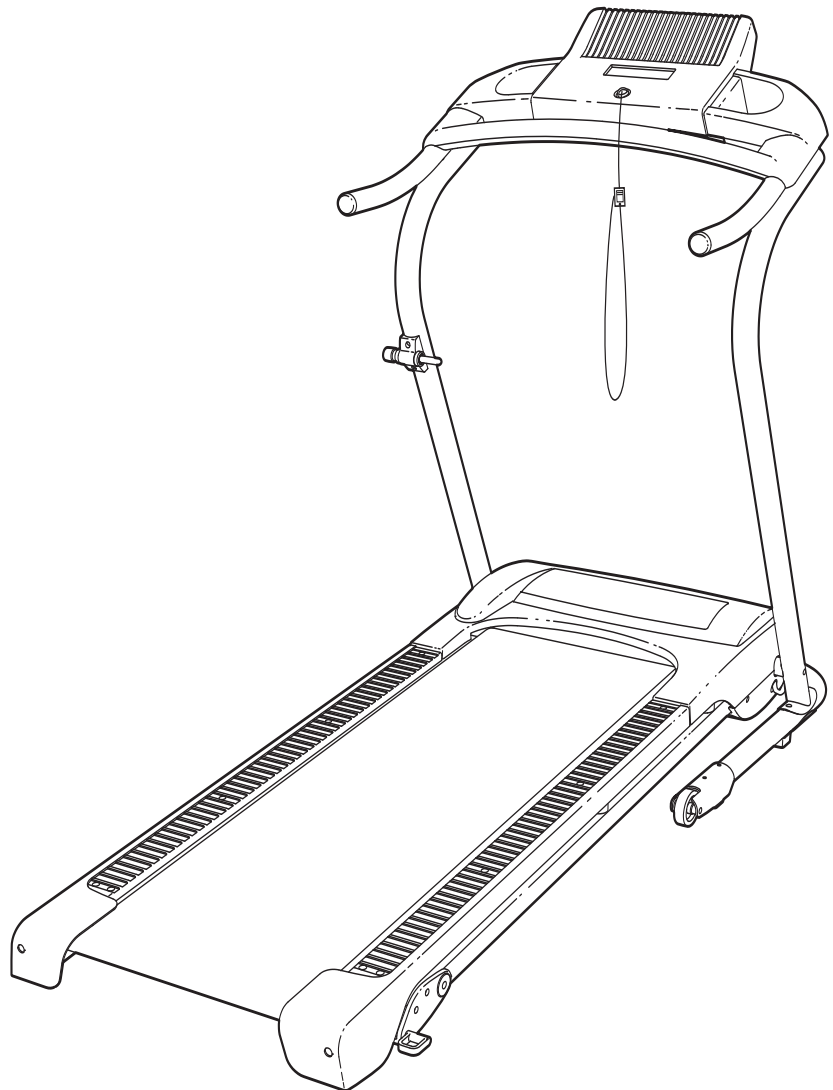

### QUESTIONS?

As a manufacturer, we are committed to providing complete customer satisfaction. If you have questions, or if parts are missing, **PLEASE DO NOT CONTACT THE STORE;** please contact Customer Care.

**IMPORTANT:** You must note the product model number and serial number (see the drawing above) before contacting us:

CALL TOLL-FREE:

**1-866-699-3756**

Mon.–Fri. 6 a.m.–6 p.m. MST

Sat. 8 a.m.–4 p.m. MST

ON THE WEB:

[www.wesloservice.com](http://www.wesloservice.com)

### CAUTION

Read all precautions and instructions in this manual before using this equipment. Save this manual for future reference.



Visit our website at

[www.weslo.com](http://www.weslo.com)

new products, prizes,  
fitness tips, and much more!

# TABLE OF CONTENTS

WARNING DECAL PLACEMENT .....2  
 IMPORTANT PRECAUTIONS .....3  
 BEFORE YOU BEGIN .....5  
 ASSEMBLY .....6  
 OPERATION AND ADJUSTMENT .....11  
 HOW TO FOLD AND MOVE THE TREADMILL .....16  
 TROUBLESHOOTING .....18  
 EXERCISE GUIDELINES .....20  
 PART LIST .....22  
 EXPLODED DRAWING .....24  
 ORDERING REPLACEMENT PARTS ..... Back Cover  
 LIMITED WARRANTY ..... Back Cover

## WARNING DECAL PLACEMENT

The decal shown here has been applied in the location shown. **If the decal is missing or illegible, call the telephone number on the front cover of this manual and request a free replacement decal. Apply the decal in the location shown.** Note: The decal may not be shown at actual size.

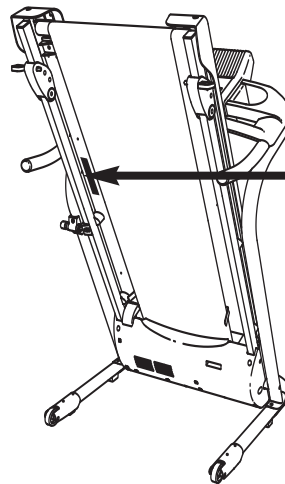

**▲WARNING:**  
 Protect yourself and others from risk of serious injury. Read the user's manual and :

-  •Stand only on the side rails when starting or stopping treadmill.
- Change speed in small increments.
- Hold handrails to prevent falling, and always wear the safety clip while operating treadmill.
- Stop if you feel faint, dizzy, or short of breath.
- Fully engage storage latch before treadmill is moved or stored.
- Reduce incline to its lowest level before folding treadmill into storage position.

---

-  •Never allow children on or around treadmill.
- Remove key when not in use.

---

-  •Keep clothing, fingers, and hair away from moving belt.
- Never try to adjust or fix the belt while it is moving.

---

-  •Always wear athletic shoes while operating treadmill.

# IMPORTANT PRECAUTIONS

**⚠️ WARNING:** To reduce the risk of serious injury, read all important precautions and instructions in this manual and all warnings on your treadmill before using your treadmill. ICON assumes no responsibility for personal injury or property damage sustained by or through the use of this product.

1. Before beginning any exercise program, consult your physician. This is especially important for persons over the age of 35 or persons with pre-existing health problems.
2. It is the responsibility of the owner to ensure that all users of this treadmill are adequately informed of all warnings and precautions.
3. Use the treadmill only as described.
4. Place the treadmill on a level surface, with at least 8 ft. (2.4 m) of clearance behind it and 2 ft. (0.6 m) on each side. Do not place the treadmill on any surface that blocks air openings. To protect the floor or carpet from damage, place a mat under the treadmill.
5. Keep the treadmill indoors, away from moisture and dust. Do not put the treadmill in a garage or covered patio, or near water.
6. Do not operate the treadmill where aerosol products are used or where oxygen is being administered.
7. Keep children under the age of 12 and pets away from the treadmill at all times.
8. The treadmill should be used only by persons weighing 250 lbs. (113 kg) or less.
9. Never allow more than one person on the treadmill at a time.
10. Wear appropriate exercise clothes when using the treadmill. Do not wear loose clothes that could become caught in the treadmill. Athletic support clothes are recommended for both men and women. *Always wear athletic shoes. Never use the treadmill with bare feet, wearing only stockings, or in sandals.*
11. When connecting the power cord (see page 11), plug the power cord into a surge suppressor (not included) and plug the surge suppressor into a grounded circuit capable of carrying 15 or more amps. No other appliance should be on the same circuit. Do not use an extension cord.
12. Use only a single-outlet surge suppressor that meets all of the specifications described on page 11. To purchase a surge suppressor, see your local WESLO dealer or call the telephone number on the front cover of this manual and order part number 146148, or see your local electronics store.
13. Failure to use a properly functioning surge suppressor could result in damage to the control system of the treadmill. If the control system is damaged, the walking belt may change speed, accelerate, or stop unexpectedly, which may result in a fall and serious injury.
14. Keep the power cord and the surge suppressor away from heated surfaces.
15. Never move the walking belt while the power is turned off. Do not operate the treadmill if the power cord or plug is damaged, or if the treadmill is not working properly. (See TROUBLESHOOTING on page 18 if the treadmill is not working properly.)
16. Read, understand, and test the emergency stop procedure before using the treadmill (see HOW TO TURN ON THE POWER on page 13).
17. Never start the treadmill while you are standing on the walking belt. Always hold the handrails while using the treadmill.
18. The treadmill is capable of high speeds. Adjust the speed in small increments to avoid sudden jumps in speed.
19. Never leave the treadmill unattended while it is running. Always remove the key, unplug the power cord, and switch the reset/off circuit breaker to the off position when the treadmill is not in use. (See the drawing on page 5 for the location of the circuit breaker.)

20. Do not attempt to raise, lower, or move the treadmill until it is properly assembled. (See ASSEMBLY on page 6, and HOW TO FOLD AND MOVE THE TREADMILL on page 16.) You must be able to safely lift 45 lbs. (20 kg) to raise, lower, or move the treadmill.
21. When folding or moving the treadmill, make sure that the storage latch is fully closed.
22. Never insert any object into any opening on the treadmill.
23. Inspect and properly tighten all parts of the treadmill regularly.

24. **DANGER:** Always unplug the power cord immediately after use, before cleaning the treadmill, and before performing the maintenance and adjustment procedures described in this manual. Never remove the motor hood unless instructed to do so by an authorized service representative. Servicing other than the procedures in this manual should be performed by an authorized service representative only.
25. This treadmill is intended for in-home use only. Do not use this treadmill in a commercial, rental, or institutional setting.

**SAVE THESE INSTRUCTIONS**

# BEFORE YOU BEGIN

Thank you for selecting the new WESLO® 225 GTX treadmill. The 225 GTX treadmill combines advanced technology with innovative design to make your workouts at home more effective and enjoyable. And when you're not exercising, the 225 GTX treadmill can be folded up, requiring less than half the floor space of other treadmills.

**For your benefit, read this manual carefully before using the treadmill.** If you have questions after reading this manual, please see the front cover of this man-

ual. To help us assist you, note the product model number and serial number before contacting us. The model number and the location of the serial number decal are shown on the front cover of this manual.

**To avoid a registration fee for any service needed under warranty, you must register the treadmill at [www.wesloservice.com/registration](http://www.wesloservice.com/registration).**

Before reading further, please familiarise yourself with the parts that are labelled in the drawing below.

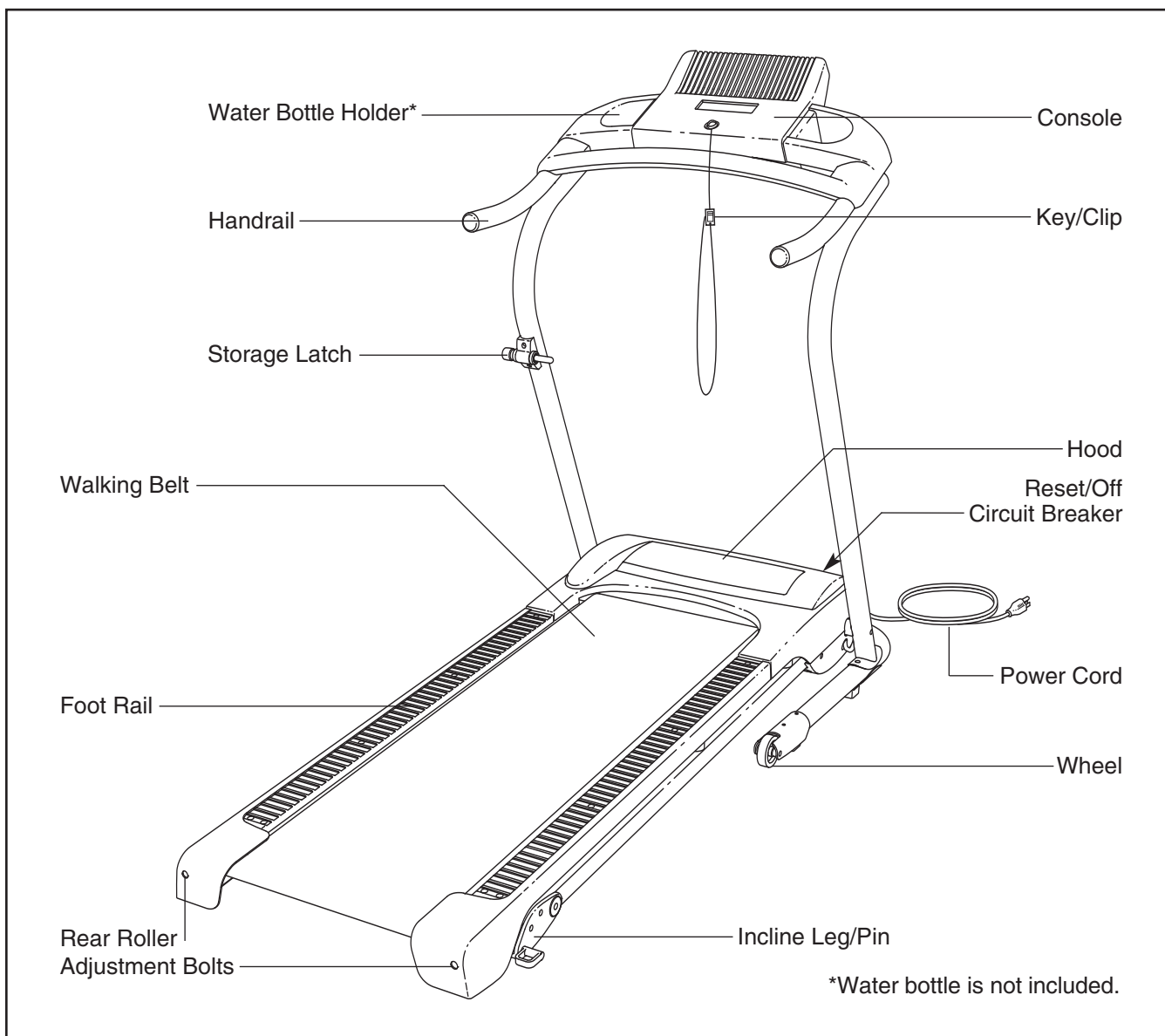

# ASSEMBLY

To hire an authorized service technician to assemble the treadmill, call 1-800-445-2480.

**Assembly requires two persons.** Set the treadmill in a cleared area and remove all packing materials; **do not dispose of the packing materials until assembly is completed.** Note: The underside of the treadmill walking belt is coated with high-performance lubricant. During shipping, a small amount of lubricant may be transferred to the top of the walking belt or the shipping carton. This does not affect treadmill performance. If there is lubricant on top of the walking belt, simply wipe off the lubricant with a soft cloth and a mild, non-abrasive cleaner.

**Assembly requires the included hex key  and your own Phillips screwdriver , two adjustable wrenches , and wire cutters .**

Use the drawings below to identify the assembly hardware. The number in parentheses below each drawing is the key number of the part, from the PART LIST near the end of the manual. The number after the parentheses shows the quantity needed for assembly. **Note: If a part is not in the parts bag, check to see if it is pre-attached to one of the parts to be assembled. Extra hardware may be included. To avoid damaging plastic parts, do not use power tools for assembly.**

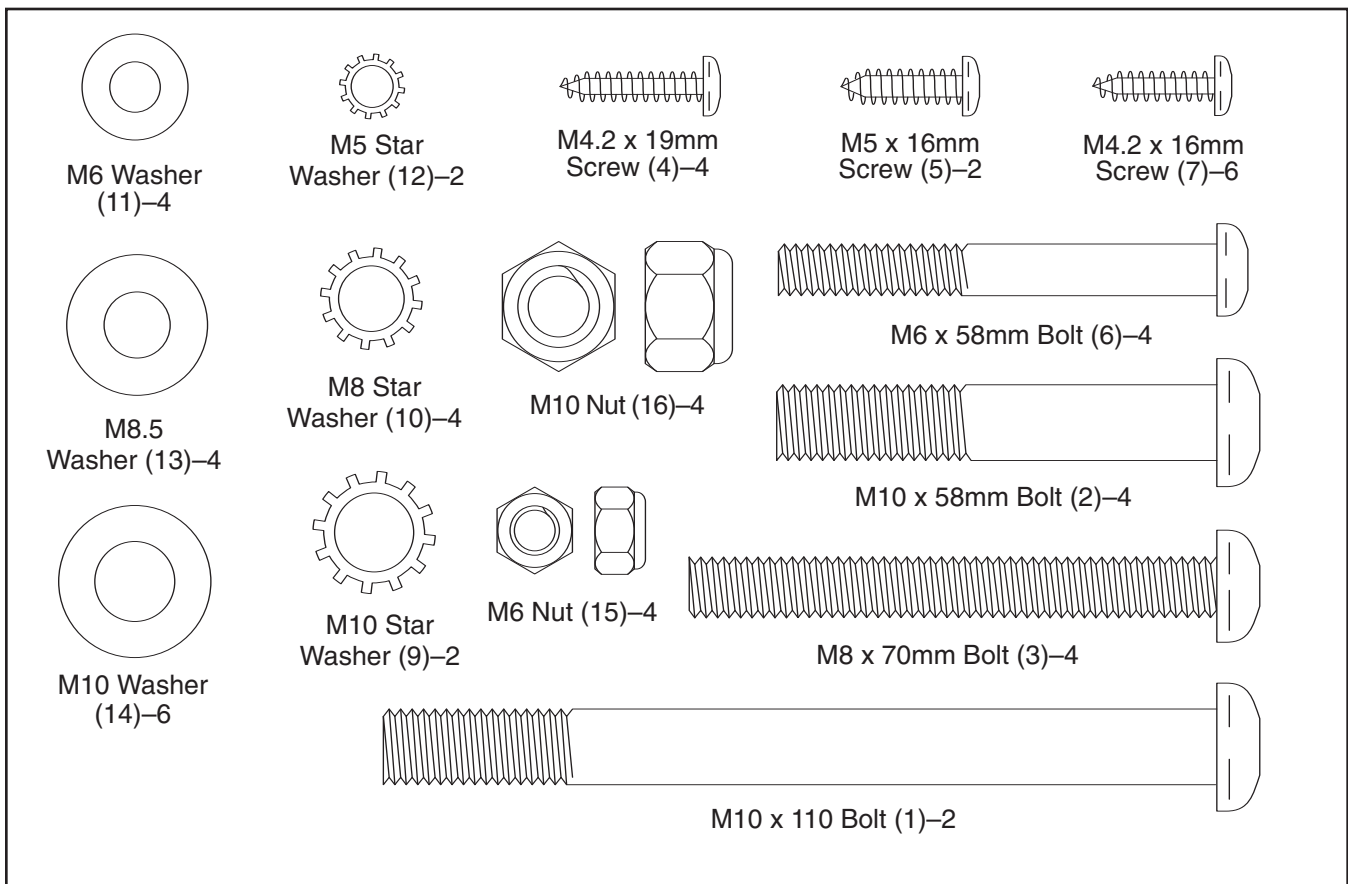

1. Have a second person hold the Base (52) in the position shown.

Identify the Left Upright (53) (the Right Upright [54] has a large hole near the lower end).

**Hold the Left Upright (53) so the bend is in the position shown. Insert two M10 x 58mm Bolts (2) into the bracket on the Left Upright. Attach the Left Upright to the Base (52) with the Bolts, two M10 Washers (14), and two M10 Nuts (16). Do not tighten the Nuts yet.**

**Attach the Right Upright (54) to the Base (52) in the same way.**

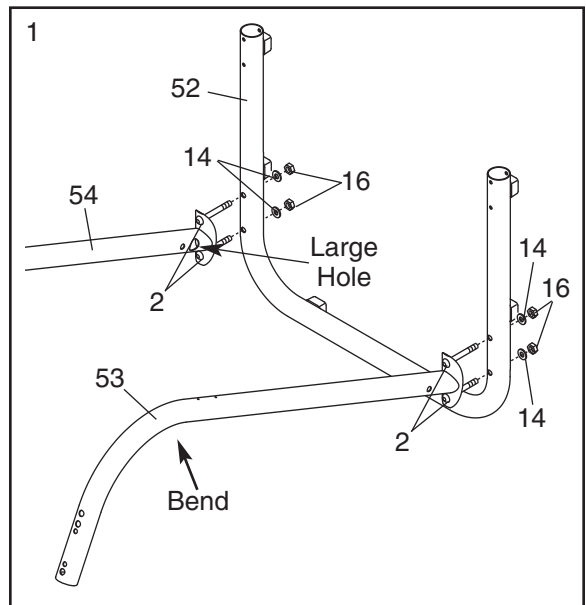

2. Slide the two Wheel Housings (62) onto the Base (52) with the head of the M10 x 62mm Bolts (35) on the outside as shown. Attach each Wheel Housing with two M6 x 58mm Bolts (6), two M6 Washers (11), and two M6 Nuts (15).

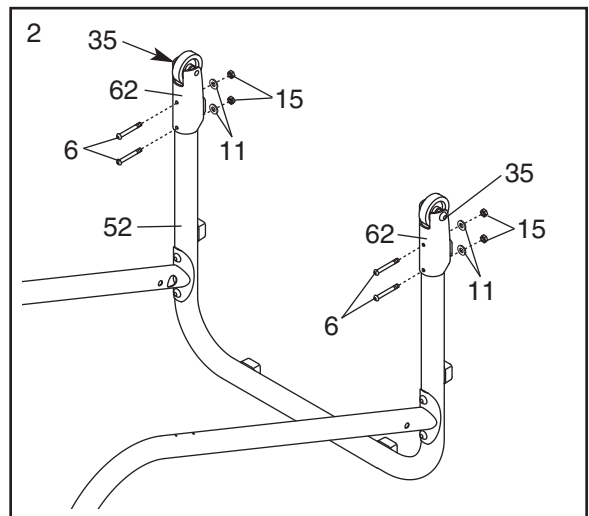

- With the help of a second person, raise the Uprights (53, 54) so the Base (52) is flat on the floor as shown. Next, position the front of the treadmill Frame (51) between the Uprights.

**See the inset drawing.** Locate the wire inside of the lower end of the Right Upright (54). Secure the wire to the Wire Harness (98) using the included plastic tie. Then, pull the upper end of the wire until the end of the Wire Harness is extending from the indicated hole in the upper end of the Right Upright.

Have a second person lift and hold the front end of the Frame (51). Hold a Frame Spacer (23) between the Right Upright (54) and the Frame. Attach the Right Upright and the Frame Spacer to the Frame with an M10 x 110mm Bolt (1), an M10 Washer (14), and an M10 Star Washer (9).

**Repeat this step on the left side of the treadmill.**

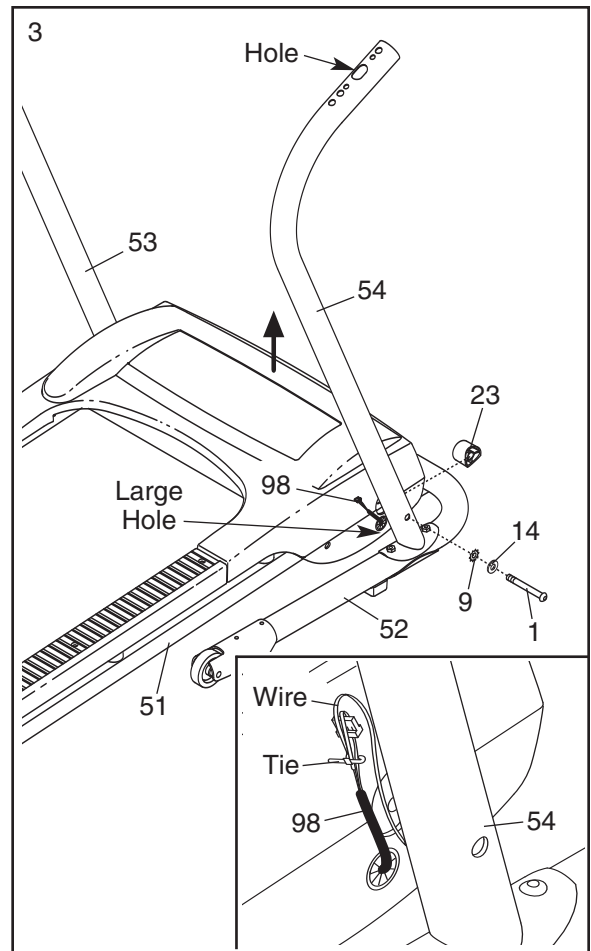

- Turn the Console (91) face-down. **Be careful not to scratch the face of the Console.**

Identify the Right Handrail (55), which has a large hole in one side.

Attach the Right Handrail (55) to the Console (91) with two M4.2 x 19mm Screws (4), an M5 x 16mm Screw (5), and an M5 Star Washer (12).

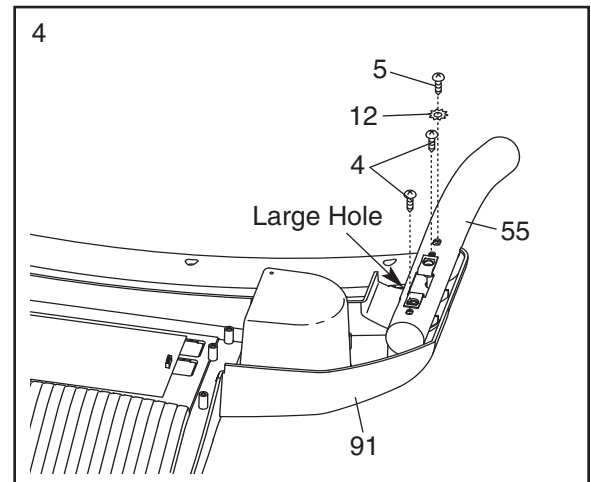



- Place the Left Handrail (56) on the Console (91). Attach the Left Handrail (56) to the Console with two M4.2 x 19mm Screws (4), an M5 x 16mm Screw (5), and an M5 Star Washer (12).

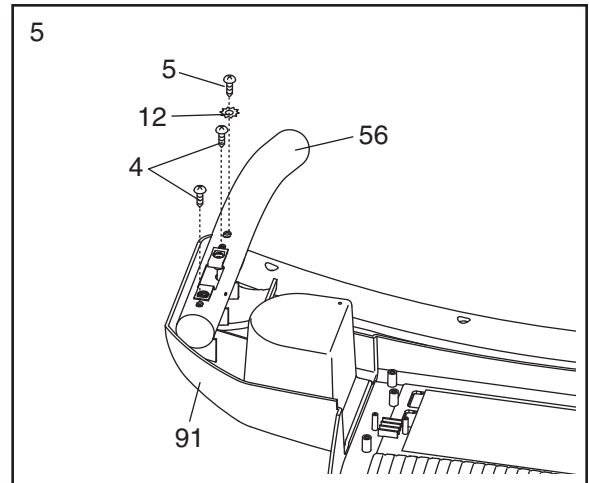

- Hold the Console (91) near the Right Upright (54). **Touch the Right Handrail to discharge any static.**

Insert the end of the Wire Harness (98) into the hole in the bottom of the Right Handrail (55) and out of the large hole in the side. Next, Insert the end of the Wire Harness through the two looped plastic ties.

Press the end of the Wire Harness (98) into the indicated connector on the back of the Console (91). **See the inset drawing. The end of the Wire Harness should slide easily into the connector and snap into place.** If it does not, turn the end of the Wire Harness and try again. **IF THE CONNECTOR IS NOT INSERTED PROPERLY, THE CONSOLE MAY BE DAMAGED WHEN THE POWER IS TURNED ON.**

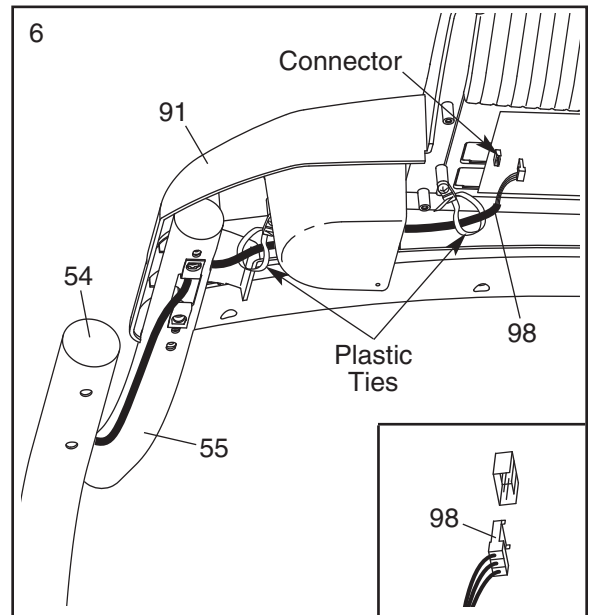

- Insert the slack in the Wire Harness (98) down into the Right Upright (54). Then, tighten the two plastic ties around the Wire Harness, and cut off the ends of the plastic ties.

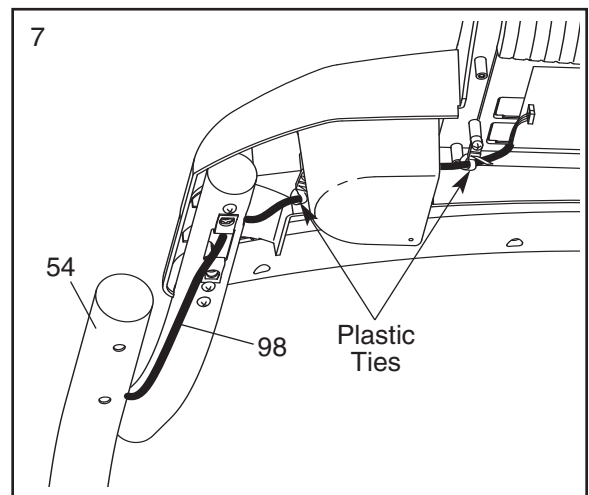

8. Set the Console (91) on the Right Upright (54) and the Left Upright (not shown). Next, start four M8 x 70mm Bolts (3) with four M8.5 Washers (13) and four M8 Star Washers (10) (only two of each are shown) into the Right Upright and the Left Upright. **Then, tighten all four Bolts.**

Insert the slack in the Wire Harness (98) down into the Right Upright (54).

Attach the Console Back (93) to the Console (91) with four M4.2 x 16mm Screws (7). **Make sure that the Wire Harness (98) is in the indicated slot in the Console Back and that no wires are pinched.**

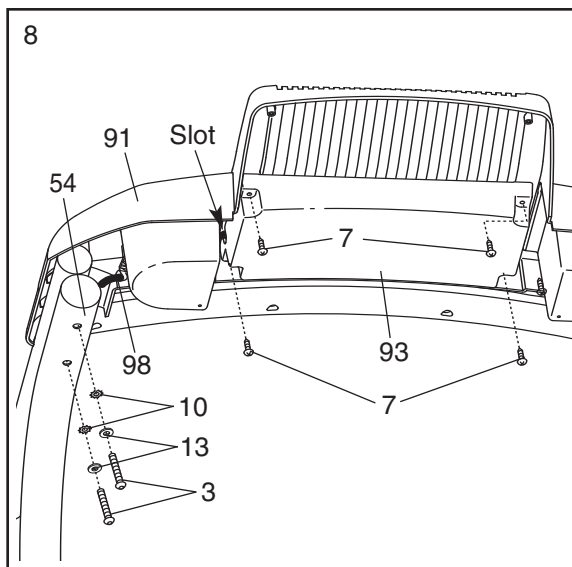

9. Carefully lower the Handrails (55, 56) to the floor. Center the Frame (51) between the Handrails, and tighten the four M10 x 58mm Bolts (2) (**see step 1**). Then, raise the Handrails back to the vertical position.

**See the inset drawing.** Attach the Latch Assembly (50) to the Left Upright (53) with two M4.2 x 16mm Screws (7). **Make sure that the Latch Assembly is oriented as shown.**

See HOW TO CHANGE THE INCLINE OF THE TREADMILL on page 15. Adjust the incline of the treadmill as desired.

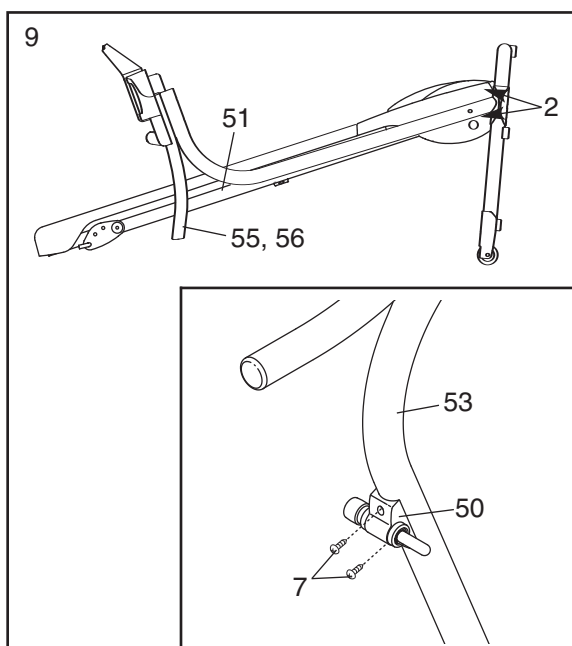

10. **Make sure that all parts are properly tightened before you use the treadmill.** Note: Extra hardware may be included. Keep the included hex keys in a secure place; the large hex key is used to adjust the walking belt (see page 19). To protect the floor or carpet, place a mat under the treadmill.

# OPERATION AND ADJUSTMENT

## THE PRE-LUBRICATED WALKING BELT

Your treadmill features a walking belt coated with high-performance lubricant. **IMPORTANT: Never apply silicone spray or other substances to the walking belt or the walking platform. Such substances will deteriorate the walking belt and cause excessive wear.**

## HOW TO PLUG IN THE POWER CORD

**⚠ DANGER:** Improper connection of the equipment-grounding conductor can result in an increased risk of electric shock. Check with a qualified electrician or serviceman if you are in doubt as to whether the product is properly grounded. Do not modify the plug provided with the product—if it will not fit the outlet, have a proper outlet installed by a qualified electrician.

Your treadmill, like any other type of sophisticated electronic equipment, can be seriously damaged by sudden voltage changes in your home's power. Voltage surges, spikes, and noise interference can result from weather conditions or from other appliances being turned on or off. **To decrease the possibility of your treadmill being damaged, always use a surge suppressor with your treadmill (see drawing 1 at the right).** To purchase a surge suppressor, see your local WESLO dealer or call the telephone number on the front cover of this manual and order part number 146148, or see your local electronics store.

Use only a single-outlet surge suppressor that is UL 1449 listed as a transient voltage surge suppressor (TVSS). The surge suppressor must have a UL suppressed voltage rating of 400 volts or less and a minimum surge dissipation of 450 joules. The surge suppressor must be electrically rated for 120 volts AC and 15 amps. There must be a monitoring light on the surge suppressor to indicate whether it is functioning properly. Failure to use a properly functioning surge suppressor could result in damage to the control system of the treadmill. If the control system is damaged, the walking belt may change speed, accelerate or stop unexpectedly, which may result in a fall and serious injury.

**This product must be grounded.** If it should malfunction or break down, grounding provides a path of least resistance for electric current, reducing the risk of elec-

tric shock. This product is equipped with a cord having an equipment-grounding conductor and a grounding plug. **Plug the power cord into a surge suppressor, and plug the surge suppressor into an appropriate outlet that is properly installed and grounded in accordance with all local codes and ordinances. Important: The treadmill is not compatible with GFCI-equipped outlets.**

This product is for use on a nominal 120-volt circuit, and has a grounding plug that looks like the plug illustrated in drawing 1 below. A temporary adapter that looks like the adapter illustrated in drawing 2 may be used to connect the surge suppressor to a 2-pole receptacle as shown in drawing 2 if a properly grounded outlet is not available.

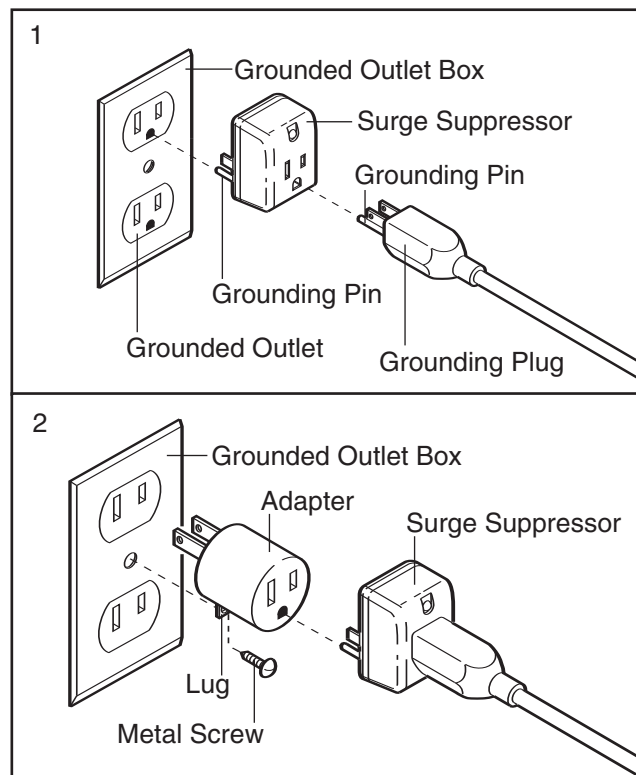

The temporary adapter should be used only until a properly grounded outlet (drawing 1) can be installed by a qualified electrician.

The green-colored rigid ear, lug, or the like extending from the adapter must be connected to a permanent ground such as a properly grounded outlet box cover. Whenever the adapter is used it must be held in place by a metal screw. **Some 2-pole receptacle outlet box covers are not grounded. Contact a qualified electrician to determine if the outlet box cover is grounded before using an adapter.**

## CONSOLE DIAGRAM

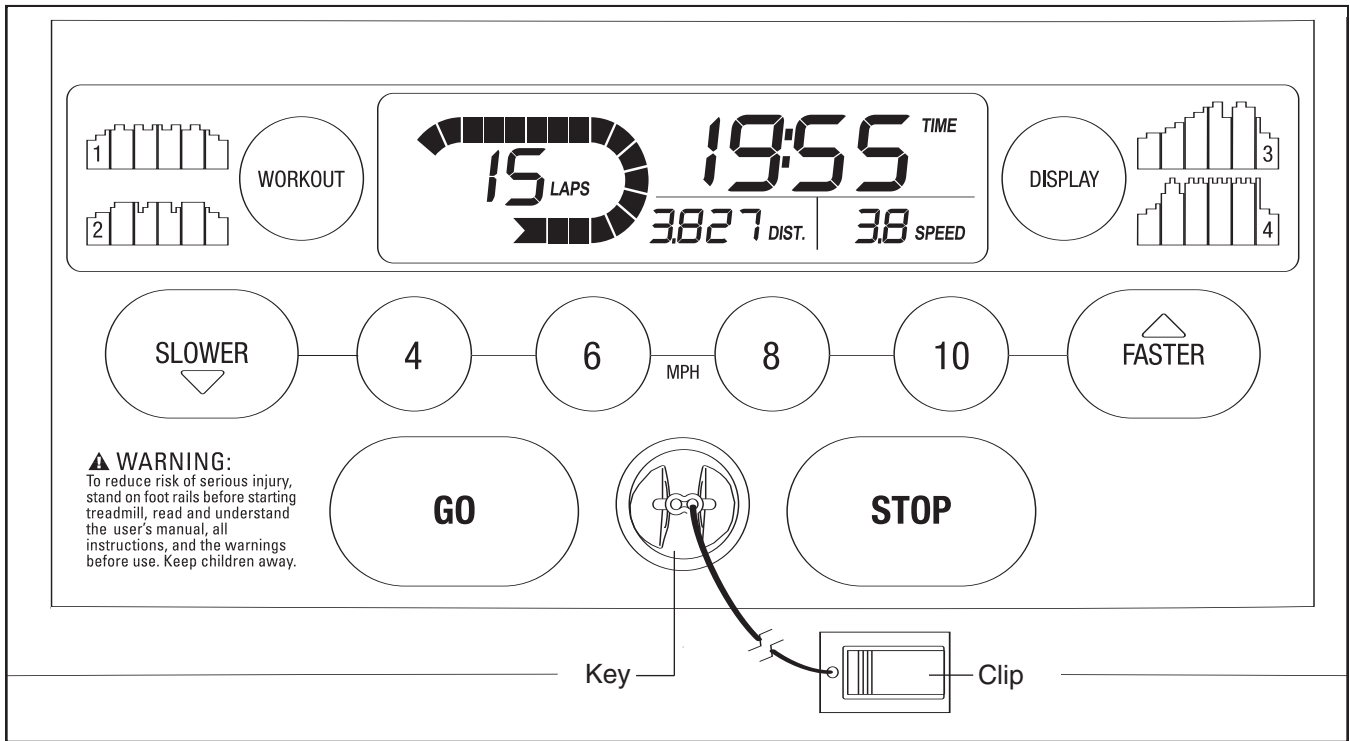

### FEATURES OF THE CONSOLE

The treadmill console offers a selection of features designed to make your workouts more effective.

When the manual mode of the console is selected, the speed of the treadmill can be changed with the touch of a button. As you exercise, the displays will provide continuous exercise feedback.

The console also offers four speed workouts. Each workout automatically controls the speed of the treadmill as it guides you through an effective workout.

To use the manual mode of the console, follow the steps beginning on page 13. To use a speed workout, see page 14.

**IMPORTANT:** If there is a sheet of clear plastic on the console, remove the plastic. To prevent damage to the walking platform, wear clean athletic shoes while using the treadmill. The first time you use the treadmill, observe the alignment of the walking belt, and center the walking belt if necessary (see page 19).

## HOW TO TURN ON THE POWER

**IMPORTANT:** If the treadmill has been exposed to cold temperatures, allow it to warm to room temperature before turning on the power. If you do not do this, the console displays or other electrical components may become damaged.

Plug in the power cord (see page 11). Next, locate the reset/off circuit breaker on the treadmill frame near the power cord. Switch the circuit breaker to the reset position.

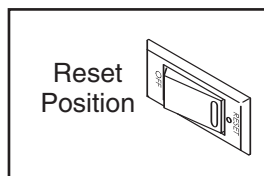

Next, stand on the foot rails of the treadmill. Find the clip attached to the key (see the drawing on page 12) and slide the clip onto the waistband of your clothes. Then, insert the key into the console. After a moment, the displays will light. **IMPORTANT:** In an emergency situation, the key can be pulled from the console, causing the walking belt to slow to a stop. Test the clip by carefully taking a few steps backward; if the key is not pulled from the console, adjust the position of the clip.

## HOW TO USE THE MANUAL MODE

### 1. Insert the key into the console.

See HOW TO TURN ON THE POWER above.

### 2. Select the manual mode.

When the key is inserted, the manual mode will be selected. If you have selected a speed workout, reselect the manual mode by pressing the Workout button repeatedly until only zeros appear in the displays.



### 3. Start the walking belt.

To start the walking belt, press the Go button, the Faster button, or one of the four numbered speed buttons.

If you press the Go button or the Faster button, the walking belt will begin to move at 1 mph. As you exercise, change the speed of the walking belt as desired by pressing the Faster and Slower buttons. Each time you press a button, the speed setting will change by 0.1 mph; if you hold down a button, the speed setting will change by 0.5 mph. Note: After you press the buttons, it may take a moment for the walking belt to reach the selected speed setting.

If you press one of the four numbered speed buttons, the walking belt will gradually increase in speed until it reaches the selected speed setting.

To stop the walking belt, press the Stop button. The time will begin to flash in one of the displays. To restart the walking belt, press the Go button, the Faster button, or one of the numbered speed buttons.

### 4. Follow your progress with the displays.

**The track**—The track represents a distance of 1/4 mile (400 meters). As you walk or run on the treadmill, the indicators around the track will appear in succession until the entire track appears. The track will then disappear and the indicators will again begin to appear in succession. The center of the track will show the number of laps that you have completed.

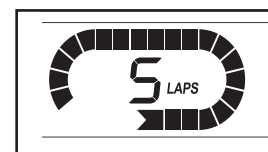

**The lower left display**—As you exercise, the lower left display can show the elapsed time and the distance that you have walked or run.



Note: When a speed workout is selected, the lower left corner of the display will show the time remaining in the workout instead of the elapsed time.

**The lower right display**—The lower right display can show the speed of the walking belt and the approximate number of calories that you have burned.

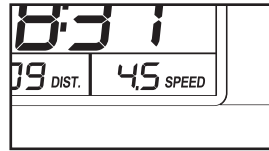

**The priority display**—

The upper display is the *priority display*. The priority display can show the elapsed time, the distance that you have walked or run, the speed of the walking belt, or the approximate number of calories you have burned. Press the Display button repeatedly until the priority display shows the information that you are most interested in viewing. Note: While information is shown in the priority display, the same information will not be shown in the lower left or right display.



To reset the displays, press the Stop button, remove the key, and then reinsert the key.

Note: The console can display speed and distance in either miles or kilometers. To see which unit of measurement is selected, hold down the Stop button, insert the key into the console, and then release the Stop button. An “M” for metric kilometers or an “E” for English miles will appear in the priority display. Press the Faster button to change the unit of measurement. When the desired unit of measurement is selected, remove the key and then reinsert it.

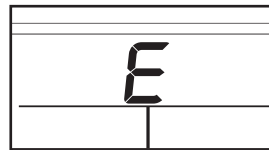

**5. When you are finished exercising, remove the key from the console.**

Step onto the foot rails, press the Stop button, remove the key from the console, and put it in a secure place. When you are finished using the treadmill, switch the reset/off circuit breaker to the “off” position and unplug the power cord. **IMPORTANT: If you do not do this, the treadmill’s electrical components may wear prematurely.**

**HOW TO USE A SPEED WORKOUT**

**1. Insert the key into the console.**

See HOW TO TURN ON THE POWER on page 13.

**2. Select one of the four speed workouts.**

To select a speed workout, press the Workout button repeatedly; “P- 1,” “P- 2,” “P- 3,” or “P- 4” will appear in the priority display for a few seconds to show which workout is selected. The maximum speed of the workout will appear in the lower right display for a few seconds. The length of the workout will then appear in the priority display.

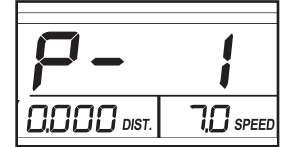

Each workout consists of 30 one-minute segments. One speed setting is programmed for each segment. Note: The same speed setting may be programmed for consecutive segments. The profiles on the console show how the speed of the walking belt will change during the workouts.

**3. Press the Go button or the Faster button to start the workout.**

When you press the button, the treadmill will automatically adjust to the speed setting that is programmed for the first segment. Hold the handrails and begin walking.

At the end of each segment, a series of tones will sound. If a different speed setting is programmed for the next segment, the speed setting will flash in the display to alert you. The workout will continue in this way until the last segment ends. The walking belt will then slow to a stop.

If the speed setting is too high or too low during the workout, you can manually override the setting by pressing the Faster and Slower buttons. **However, when the current segment of the workout ends, the treadmill will automatically adjust to the speed setting for the next segment.**

To stop the workout temporarily, press the Stop button. The time will begin to flash in the display. To restart the workout, press the Go button or the Faster button. The walking belt will begin to move at 1 mph. When the next segment begins, the treadmill will automatically adjust to the speed setting programmed for the next segment.

**4. Follow your progress with the displays.**

See step 4 on pages 13 and 14.

**5. When you are finished exercising, remove the key from the console.**

See step 5 on page 14.

## HOW TO CHANGE THE INCLINE OF THE TREADMILL

To vary the intensity of your exercise, you can change the incline of the treadmill. There are three incline levels. **Before changing the incline, remove the key and unplug the power cord.** Next, fold the treadmill to the storage position (see page 16).

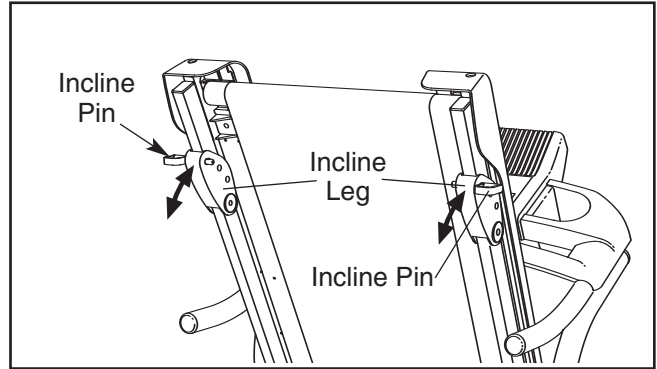

To change the incline, first remove the incline pin from one of the incline legs. Adjust the incline leg to the desired position, and then fully reinsert the incline pin. Adjust the other incline leg in the same way. **CAUTION: Before using the treadmill, make sure that both incline legs are at the same height and that both incline pins are fully inserted into the incline legs.**

After you have adjusted the incline legs, lower the treadmill (see page 17).



# HOW TO FOLD AND MOVE THE TREADMILL

## HOW TO FOLD THE TREADMILL FOR STORAGE

Unplug the power cord. **CAUTION:** You must be able to safely lift 45 lbs. (20 kg) to raise, lower, or move the treadmill.

1. Hold the metal frame firmly in the location shown by the arrow at the right. **CAUTION:** To decrease the possibility of injury, do not lift the frame by the plastic foot rails. Make sure to bend your legs and keep your back straight. As you raise the frame, make sure to lift with your legs rather than your back. Raise the frame about halfway to the vertical position.

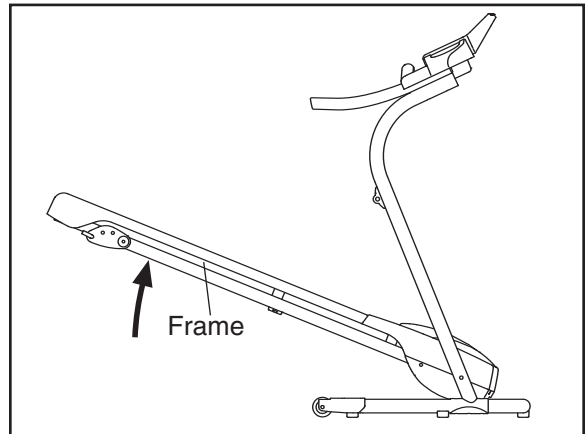

2. Move your right hand to the position shown and hold the treadmill firmly. Using your left hand, pull the latch knob to the left and hold it. Raise the frame until the catch is past the latch pin. Then, slowly release the latch knob; make sure that the frame is held securely by the latch pin.

To protect the floor or carpet from damage, place a mat under the treadmill. Keep the treadmill out of direct sunlight. Do not leave the treadmill in the storage position in temperatures above 85° F (30° C).

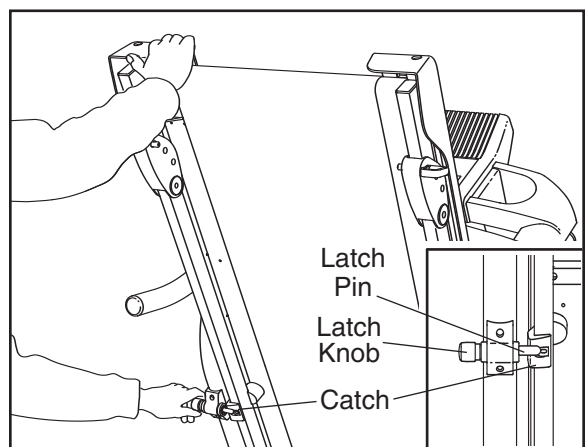

## HOW TO MOVE THE TREADMILL

Before moving the treadmill, convert the treadmill to the storage position as described above. **Make sure that the frame is held securely by the latch pin.**

1. Hold the handrails and place one foot against one of the wheels. **Do not pull back on the frame.**
2. Tilt the treadmill back until it rolls freely on the wheels, and carefully move the treadmill to the desired location. **Never move the treadmill without tipping it back. To reduce the risk of injury, use extreme caution while moving the treadmill. Do not attempt to move the treadmill over an uneven surface.**
3. Place one foot against one of the wheels, and carefully lower the treadmill until it is in the storage position.

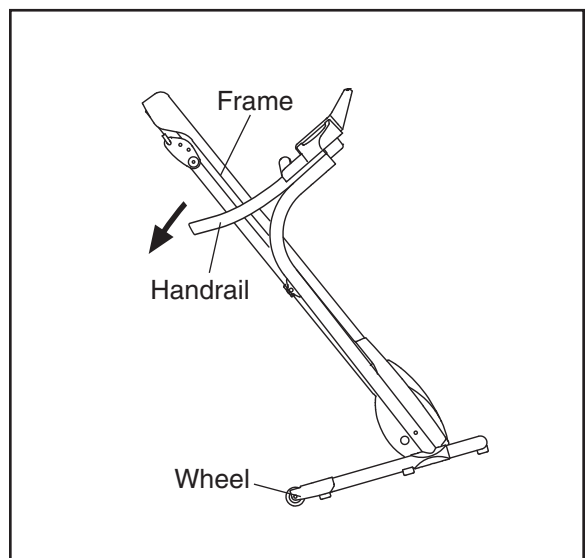



## HOW TO LOWER THE TREADMILL FOR USE

1. Hold the upper end of the treadmill with your right hand as shown. Using your left hand, pull the latch knob to the left and hold it. Next, lower the frame until it is past the latch pin. Then, slowly release the latch knob.

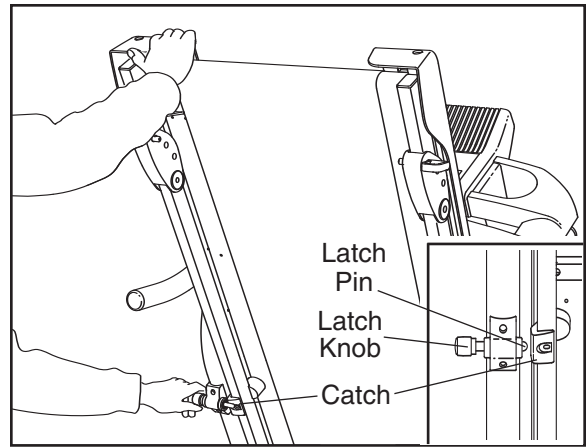

2. Hold the frame firmly with both hands, and lower it to the floor. **To decrease the possibility of injury, bend your legs and keep your back straight.**

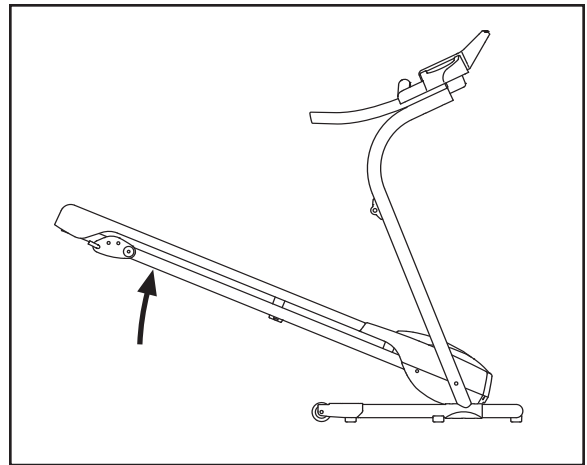

# TROUBLESHOOTING

Most treadmill problems can be solved by following the steps below. Find the symptom that applies, and follow the steps listed. If further assistance is needed, please see the front cover of this manual.

**PROBLEM: The power does not turn on**

**SOLUTION:** a. Make sure that the power cord is plugged into a surge suppressor, and that the surge suppressor is plugged into a properly grounded outlet (see page 11). Use only a single-outlet surge suppressor that meets all of the specifications described on page 11. Important: The treadmill is not compatible with GFCI-equipped outlets.

b. After the power cord has been plugged in, make sure that the key is inserted into the console.

c. Check the reset/off circuit breaker located on the treadmill frame near the power cord. If the switch protrudes as shown, the circuit breaker has tripped. To reset the circuit breaker, wait for five minutes, and then press the switch back in.

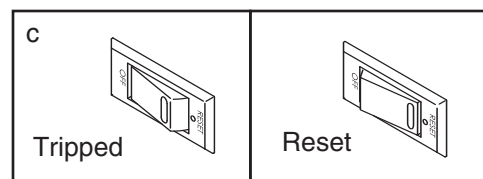

**PROBLEM: The power turns off during use**

**SOLUTION:** a. Check the reset/off circuit breaker located on the treadmill near the power cord (see c. above). If the circuit breaker has tripped, wait for five minutes and then press the switch back in.

b. Make sure that the power cord is plugged in. If the power cord is plugged in, unplug it, wait for five minutes, and then plug it back in.

c. Remove the key from the console. Reinsert the key into the console.

d. If the treadmill still will not run, see the front cover of this manual.

**PROBLEM: The displays of the console do not function properly**

**SOLUTION:** a. Remove the key from the console and **UNPLUG THE POWER CORD**. Remove the five indicated M4.2 x 10mm Screws (20) and the two M5.5 x 25mm Screws (25). Then, carefully remove the Hood (65).

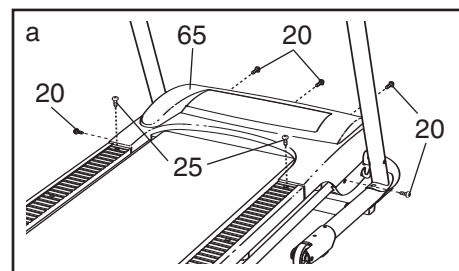

Locate the Reed Switch (97) and the Magnet (95) on the left side of the Pulley (99). Turn the Pulley until the Magnet is aligned with the Reed Switch. **Make sure that the gap between the Magnet and the Reed Switch is about 1/8 in. (3 mm)**. If necessary, loosen the M4.2 x 13mm Screw (21), move the Reed Switch slightly, and then retighten the Screw. Reattach the Hood (not shown), and run the treadmill for a few minutes to check for a correct speed reading.

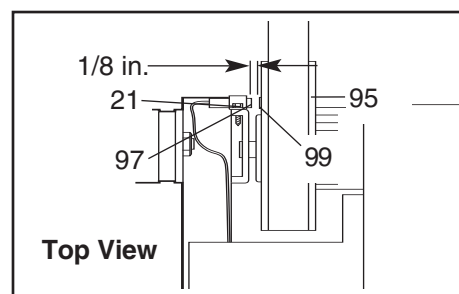

**PROBLEM: The walking belt slows when walked on**

**SOLUTION:** a. Use only a single-outlet surge suppressor that meets all the specifications described on page 11.

b. If the walking belt is overtightened, treadmill performance may decrease and the walking belt may become damaged. Remove the key and **UNPLUG THE POWER CORD**. Using the hex key, turn both rear roller bolts counterclockwise, 1/4 of a turn. When the walking belt is properly tightened, you should be able to lift each edge of the walking belt 2 to 3 in. (5 to 8 cm) off the walking platform. Be careful to keep the walking belt centered. Then, plug in the power cord, insert the key, and run the treadmill for a few minutes. Repeat until the walking belt is properly tightened.

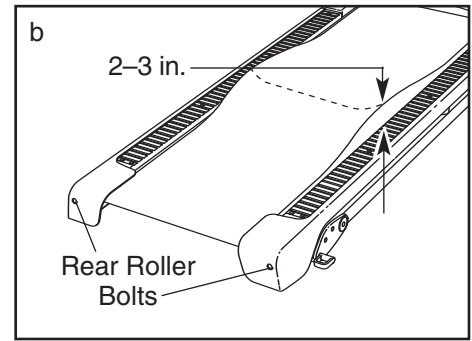

c. If the walking belt still slows when walked on, please see the front cover of this manual.

**PROBLEM: The walking belt is off-center or slips when walked on**

**SOLUTION:** a. **If the walking belt has shifted to the left**, first remove the key and **UNPLUG THE POWER CORD**. Using the hex key, turn the left rear roller bolt clockwise 1/2 of a turn. Be careful not to overtighten the walking belt. **If the walking belt has shifted to the right**, turn the left rear roller bolt counterclockwise 1/2 of a turn. Then, plug in the power cord, insert the key, and run the treadmill for a few minutes. Repeat until the walking belt is centered.

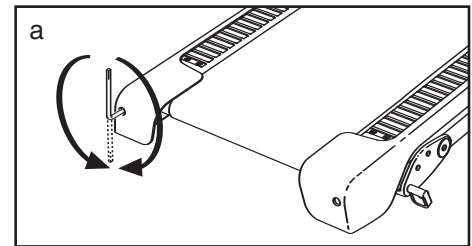

b. **If the walking belt slips when walked on**, first remove the key and **UNPLUG THE POWER CORD**. Using the hex key, turn both rear roller bolts clockwise, 1/4 of a turn. When the walking belt is correctly tightened, you should be able to lift each edge of the walking belt 2 to 3 in. (5 to 8 cm) off the walking platform. Be careful to keep the walking belt centered. Then, plug in the power cord, insert the key, and carefully walk on the treadmill for a few minutes. Repeat until the walking belt is properly tightened.

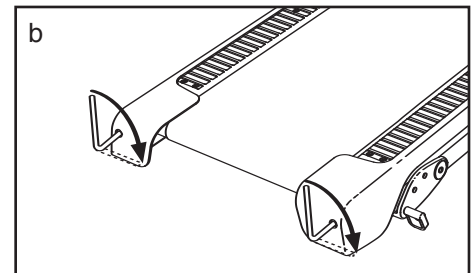

# EXERCISE GUIDELINES

**⚠️ WARNING:** Before beginning this or any exercise program, consult your physician. This is especially important for persons over the age of 35 or persons with pre-existing health problems.

These guidelines will help you to plan your exercise program. For detailed exercise information, obtain a reputable book or consult your physician. Remember, proper nutrition and adequate rest are essential for successful results.

## EXERCISE INTENSITY

Whether your goal is to burn fat or to strengthen your cardiovascular system, exercising at the proper intensity is the key to achieving results. You can use your heart rate as a guide to find the proper intensity level. The chart below shows recommended heart rates for fat burning and aerobic exercise.

165	155	145	140	130	125	115	♥️
145	138	130	125	118	110	103	♥️
125	120	115	110	105	95	90	♥️
<hr/>							
20	30	40	50	60	70	80	

To find the proper intensity level, find your age at the bottom of the chart (ages are rounded off to the nearest ten years). The three numbers listed above your age define your “training zone.” The lowest number is the heart rate for fat burning, the middle number is the heart rate for maximum fat burning, and the highest number is the heart rate for aerobic exercise.

**Burning Fat**—To burn fat effectively, you must exercise at a low intensity level for a sustained period of time. During the first few minutes of exercise, your body uses *carbohydrate calories* for energy. Only after the first few minutes of exercise does your body begin to use stored *fat calories* for energy. If your goal is to burn fat, adjust the intensity of your exercise until your heart rate is near the lowest number in your training zone. For maximum fat burning, exercise with your heart rate near the middle number in your training zone.

**Aerobic Exercise**—If your goal is to strengthen your cardiovascular system, you must perform aerobic exercise, which is activity that requires large amounts of oxygen for prolonged periods of time. For aerobic exercise, adjust the intensity of your exercise until your heart rate is near the highest number in your training zone.

## HOW TO MEASURE YOUR HEART RATE

To measure your heart rate, exercise for at least four minutes. Then, stop exercising and place two fingers on your wrist as shown. Take a six-second heartbeat count, and multiply the result by 10 to find your heart rate. For example, if your six-second heartbeat count is 14, your heart rate is 140 beats per minute.

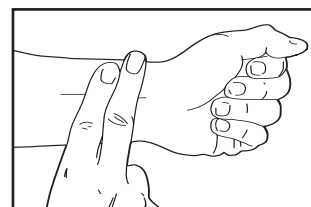

## WORKOUT GUIDELINES

**Warming up**—Start with 5 to 10 minutes of stretching and light exercise. A warm-up increases your body temperature, heart rate, and circulation in preparation for exercise.

**Training Zone Exercise**—Exercise for 20 to 30 minutes with your heart rate in your training zone. (During the first few weeks of your exercise program, do not keep your heart rate in your training zone for longer than 20 minutes.) Breathe regularly and deeply as you exercise—never hold your breath.

**Cooling down**—Finish with 5 to 10 minutes of stretching. Stretching increases the flexibility of your muscles and helps to prevent post-exercise problems.

## EXERCISE FREQUENCY

To maintain or improve your condition, complete three workouts each week, with at least one day of rest between workouts. After a few months of regular exercise, you may complete up to five workouts each week, if desired. Remember, the key to success is to make exercise a regular and enjoyable part of your everyday life.

## SUGGESTED STRETCHES

The correct form for several basic stretches is shown at the right. Move slowly as you stretch—never bounce.

### 1. Toe Touch Stretch

Stand with your knees bent slightly and slowly bend forward from your hips. Allow your back and shoulders to relax as you reach down toward your toes as far as possible. Hold for 15 counts, then relax. Repeat 3 times. Stretches: Hamstrings, back of knees and back.

### 2. Hamstring Stretch

Sit with one leg extended. Bring the sole of the opposite foot toward you and rest it against the inner thigh of your extended leg. Reach toward your toes as far as possible. Hold for 15 counts, then relax. Repeat 3 times for each leg. Stretches: Hamstrings, lower back and groin.

### 3. Calf/Achilles Stretch

With one leg in front of the other, reach forward and place your hands against a wall. Keep your back leg straight and your back foot flat on the floor. Bend your front leg, lean forward and move your hips toward the wall. Hold for 15 counts, then relax. Repeat 3 times for each leg. To cause further stretching of the achilles tendons, bend your back leg as well. Stretches: Calves, achilles tendons and ankles.

### 4. Quadriceps Stretch

With one hand against a wall for balance, reach back and grasp one foot with your other hand. Bring your heel as close to your buttocks as possible. Hold for 15 counts, then relax. Repeat 3 times for each leg. Stretches: Quadriceps and hip muscles.

### 5. Inner Thigh Stretch

Sit with the soles of your feet together and your knees outward. Pull your feet toward your groin area as far as possible. Hold for 15 counts, then relax. Repeat 3 times. Stretches: Quadriceps and hip muscles.

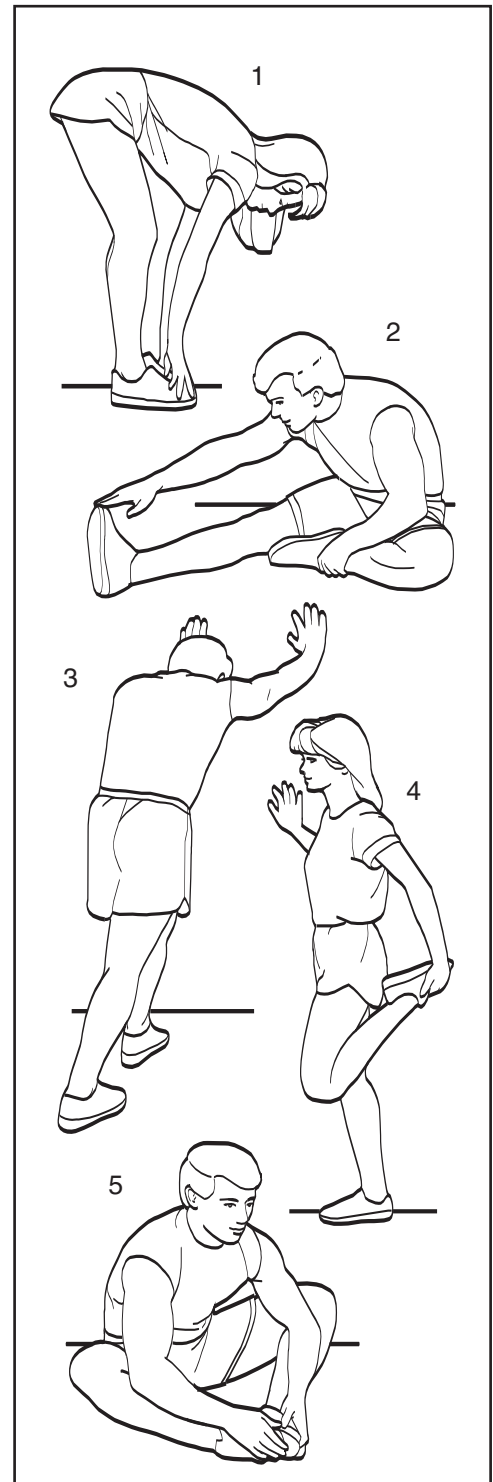

# PART LIST—Model No. WLTL19507.0

R0807A

To locate the parts listed below, see the EXPLODED DRAWING near the end of this manual.

Key No.	Qty.	Description	Key No.	Qty.	Description
1	2	M10 x 110mm Bolt	48	4	“U”-Nut
2	4	M10 x 58mm Bolt	49	2	M4 Nut
3	4	M8 x 70mm Bolt	50	1	Latch Assembly
4	4	M4.2 x 19mm Screw	51	1	Frame
5	2	M5 x 16mm Screw	52	1	Base
6	4	M6 x 58mm Bolt	53	1	Left Upright
7	6	M4.2 x 16mm Screw	54	1	Right Upright
8	1	Rear Roller	55	1	Right Handrail
9	2	M10 Star Washer	56	1	Left Handrail
10	4	M8 Star Washer	57	1	Electronics Bracket
11	4	M6 Washer	58	1	Dust Guard
12	2	M5 Star Washer	59	1	Motor Bracket
13	4	M8.5 Washer	60	1	Left Rear Roller Bracket
14	6	M10 Washer	61	1	Right Rear Roller Bracket
15	4	M6 Nut	62	2	Wheel Housing
16	6	M10 Nut	63	6	Base Pad
17	1	6 mm Hex Key	64	1	Catch
18	1	4 mm Hex Key	65	1	Hood
19	2	M8 x 35mm Screw	66	1	Belly Pan
20	5	M4.2 x 10mm Screw	67	1	Left Foot Rail
21	14	M4.2 x 13mm Screw	68	1	Right Foot Rail
22	1	M6 x 50mm Bolt	69	2	Incline Leg
23	2	Frame Spacer	70	2	Wheel
24	2	M4 x 10mm Bolt	71	4	Wheel Spacer
25	10	M5.5 x 25mm Screw	72	1	Power Cord Grommet
26	6	M4.2 x 18mm Screw	73	1	Filter Wire
27	2	M8 x 30mm Bolt	74	2	Frame Endcap
28	4	M4.2 x 13mm Belt Guide Screw	75	2	Upright Endcap
29	2	M6 x 70mm Bolt	76	4	Handrail Endcap
30	2	1/4" Motor Bolt	77	4	Platform Cushion
31	1	M8 x 98mm Bolt	78	2	Belt Guide
32	2	M8 x 52mm Bolt	79	1	Drive Motor
33	4	M6 x 23mm Screw	80	4	Wire Tie
34	2	M8 x 20mm Bolt	81	5	8" Tie
35	2	M10 x 62mm Bolt	82	1	Releasable Tie
36	2	M6 Flat Washer	83	1	Reed Switch Clip
37	3	M6 Star Washer	84	1	Belly Pan Grommet
38	2	M8.4 Star Washer	85	1	Grommet
39	2	M4 Washer	86	1	Key/Clip
40	2	Incline Pin	87	1	Controller
41	13	M4.2 x 13mm Tek Screw	88	1	Power Outlet Bracket
42	4	M4.2 Star Washer	89	1	Reset/Off Circuit Breaker
43	4	M8.5 Washer	90	1	Power Cord
44	2	M8 Motor Nut	91	1	Console
45	2	M10 Insert Nut	92	1	Console Crossbar
46	5	M8 Nut	93	1	Console Back
47	5	Hood Clip	94	1	Warning Decal

95	1	Front Roller/Pulley	*	–	4" Red Wire, M/F
96	1	Motor Belt	*	–	4" Blue Wire, 2F
97	1	Reed Switch	*	–	10" Blue Wire, 2F
98	1	Wire Harness	*	–	User's Manual
99	1	Magnet			
100	1	Walking Platform			
101	1	Walking Belt			

\*These parts are not illustrated.  
Specifications are subject to change without notice.

# EXPLODED DRAWING A—Model No. WLTL19507.0

R0807A

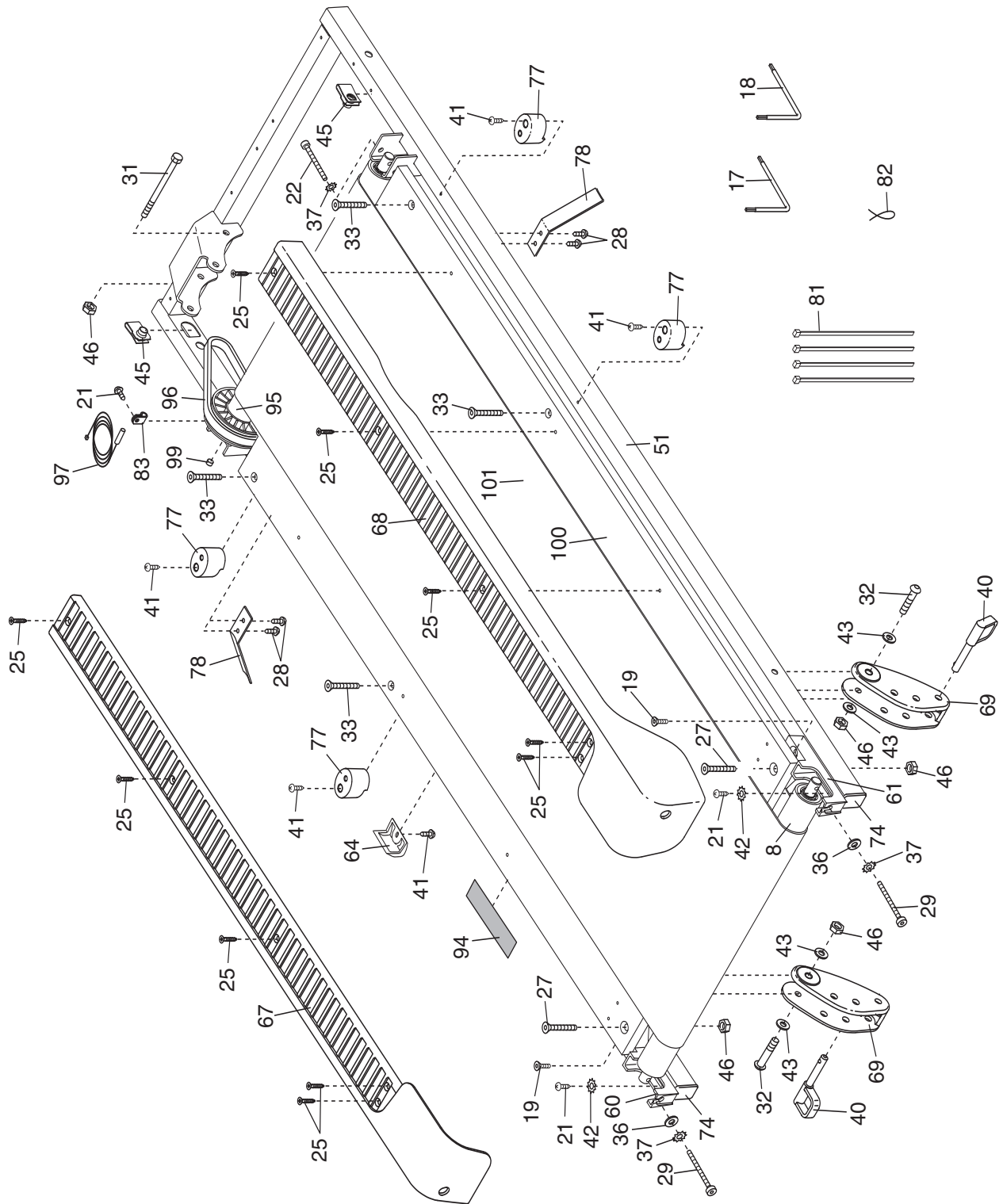



# EXPLODED DRAWING B—Model No. WLT19507.0

R0807A

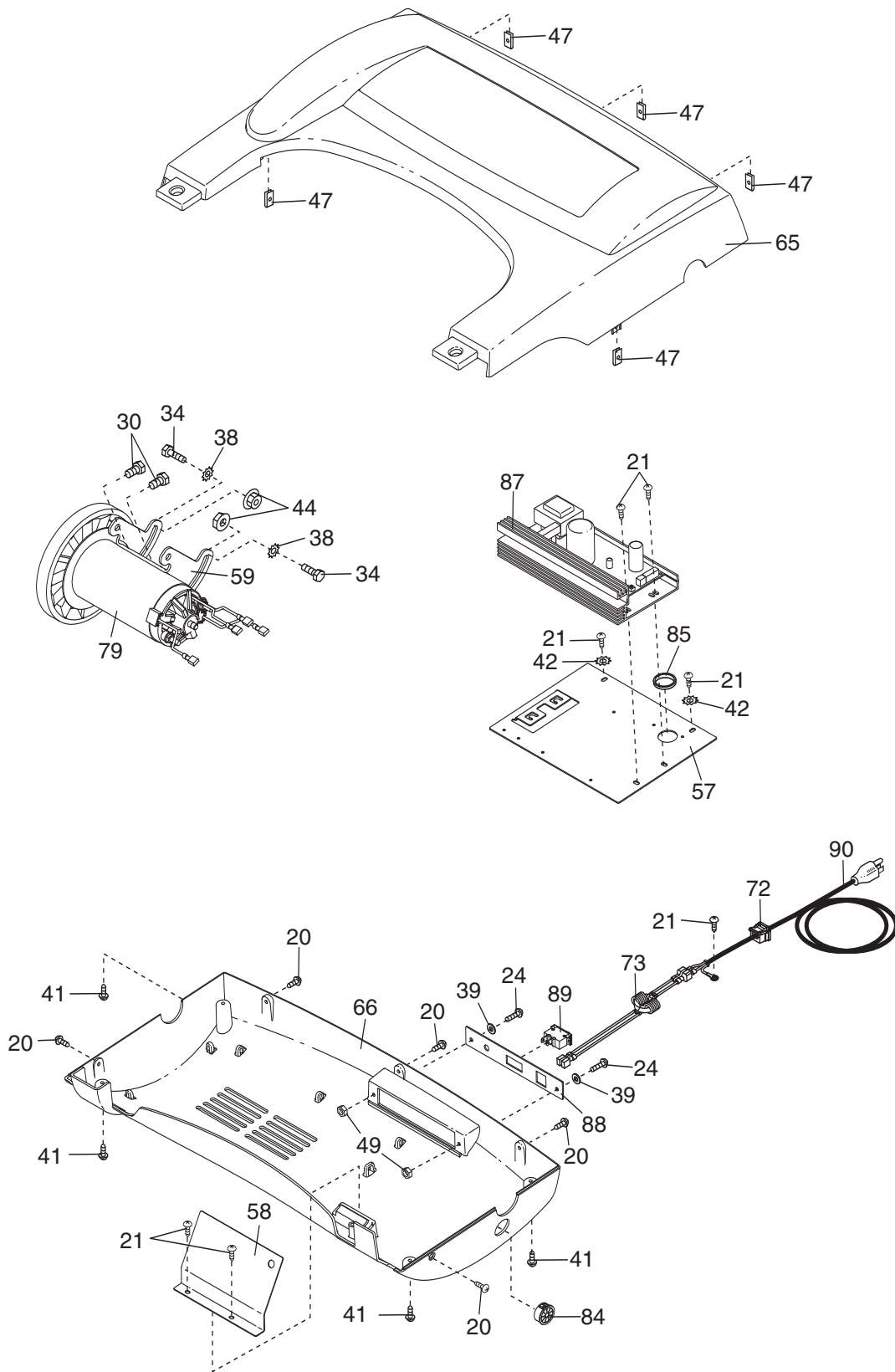

# EXPLODED DRAWING C—Model No. WLTL19507.0

R0807A

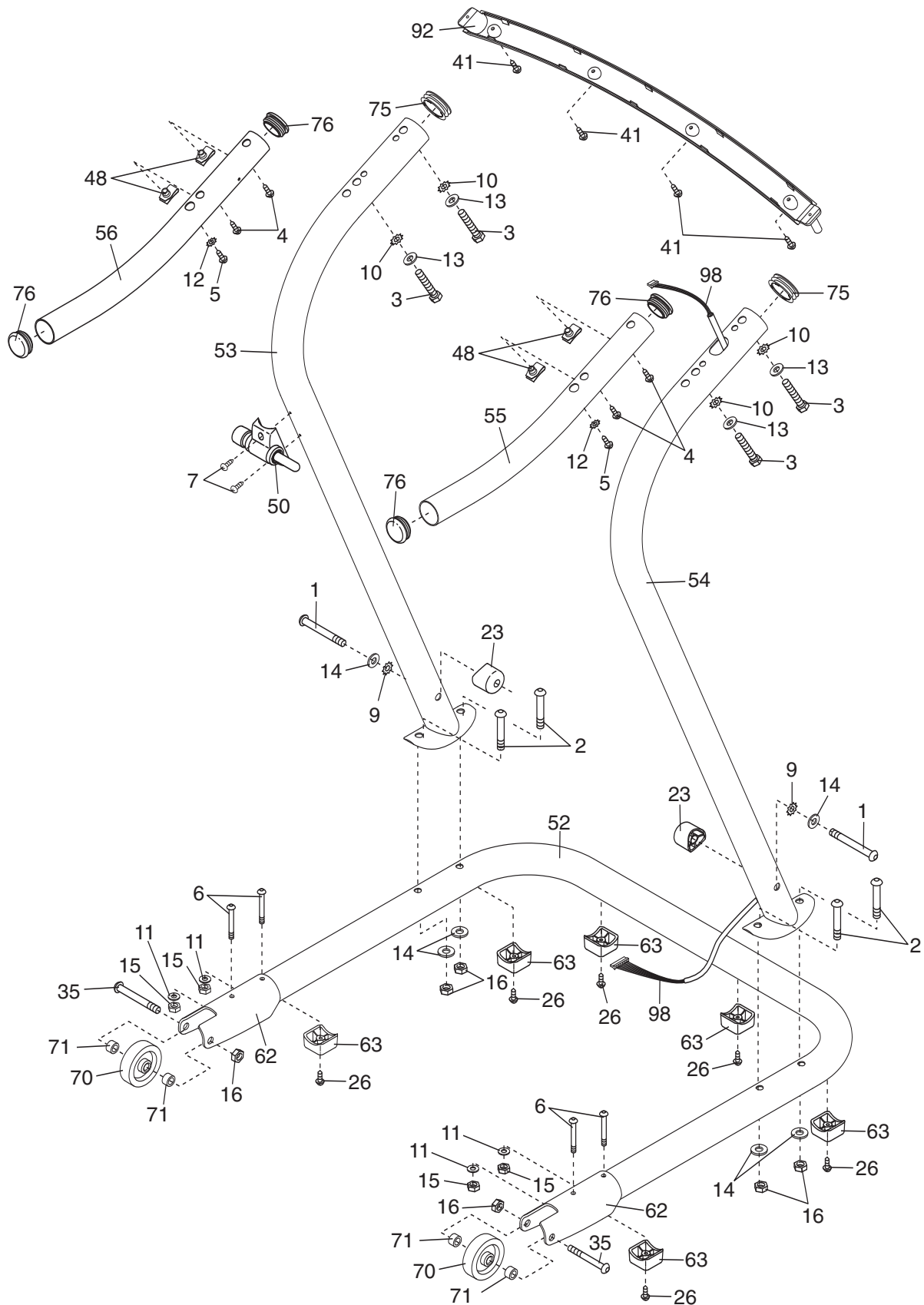

# EXPLODED DRAWING D—Model No. WLTL19507.0

R0807A

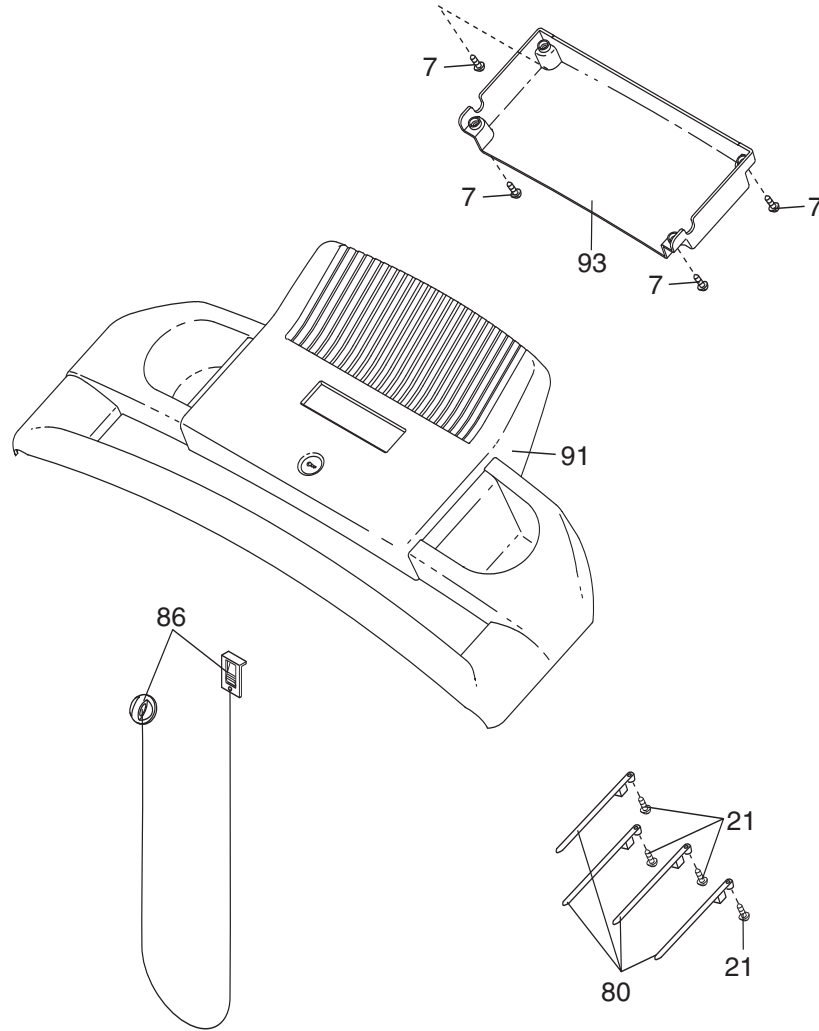

---

# ORDERING REPLACEMENT PARTS

To order replacement parts, please see the front cover of this manual. To help us assist you, be prepared to provide the following information when contacting us:

- the model number and serial number of the product (see the front cover of this manual)
- the name of the product (see the front cover of this manual)
- the key number and description of the replacement part(s) (see the PART LIST and the EXPLODED DRAWING near the end of this manual)

## LIMITED WARRANTY

ICON Health & Fitness, Inc. (ICON) warrants this product to be free from defects in workmanship and material under normal use and service conditions. The drive motor is warranted for two (2) years after the date of purchase. Parts and labor are warranted for ninety (90) days after the date of purchase.

This warranty extends only to the original purchaser. ICON's obligation under this warranty is limited to replacing or repairing, at ICON's option, the product through one of its authorized service centers. All repairs for which warranty claims are made must be pre-authorized by ICON. If the product is shipped to a service center, freight charges to and from the service center will be the customer's responsibility. For in-home service, the customer will be responsible for a minimal trip charge. This warranty does not extend to any product or damage to a product caused by or attributable to freight damage, abuse, misuse, improper or abnormal usage or repairs not provided by an ICON authorized service center; products used for commercial or rental purposes; or products used as store display models. No other warranty beyond that specifically set forth above is authorized by ICON.

ICON is not responsible or liable for indirect, special or consequential damages arising out of or in connection with the use or performance of the product or damages with respect to any economic loss, loss of property, loss of revenues or profits, loss of enjoyment or use, costs of removal or installation or other consequential damages of whatsoever nature. Some states do not allow the exclusion or limitation of incidental or consequential damages. Accordingly, the above limitation may not apply to you.

The warranty extended hereunder is in lieu of any and all other warranties and any implied warranties of merchantability or fitness for a particular purpose is limited in its scope and duration to the terms set forth herein. Some states do not allow limitations on how long an implied warranty lasts. Accordingly, the above limitation may not apply to you.

This warranty gives you specific legal rights. You may also have other rights which vary from state to state.

**ICON HEALTH & FITNESS, INC., 1500 S. 1000 W., LOGAN, UT 84321-9813**