

Smart choice for power

xantrex



ACCB-L
ACCB-L-L1

Owner's Guide

Sine Wave Plus Long AC Conduit Box Owner's Guide

www.xantrex.com

Sine Wave Plus Long AC Conduit Box

Owner's Guide

About Xantrex

Xantrex Technology Inc. is a world-leading supplier of advanced power electronics and controls with products from 50 watt mobile units to one MW utility-scale systems for wind, solar, batteries, fuel cells, microturbines, and backup power applications in both grid-connected and stand-alone systems. Xantrex products include inverters, battery chargers, programmable power supplies, and variable speed drives that convert, supply, control, clean, and distribute electrical power.

Trademarks

Sine Wave Plus Long AC Conduit Box is a trademark of Xantrex International. Xantrex is a registered trademark of Xantrex International.

Other trademarks, registered trademarks, and product names are the property of their respective owners and are used herein for identification purposes only.

Notice of Copyright

Sine Wave Plus AC Conduit Box Long Owner's Guide © June 2004 Xantrex International. All rights reserved.

Disclaimer

UNLESS SPECIFICALLY AGREED TO IN WRITING, XANTREX TECHNOLOGY INC. ("XANTREX")

(a) MAKES NO WARRANTY AS TO THE ACCURACY, SUFFICIENCY OR SUITABILITY OF ANY TECHNICAL OR OTHER INFORMATION PROVIDED IN ITS MANUALS OR OTHER DOCUMENTATION.

(b) ASSUMES NO RESPONSIBILITY OR LIABILITY FOR LOSS OR DAMAGE, WHETHER DIRECT, INDIRECT, CONSEQUENTIAL OR INCIDENTAL, WHICH MIGHT ARISE OUT OF THE USE OF SUCH INFORMATION. THE USE OF ANY SUCH INFORMATION WILL BE ENTIRELY AT THE USER'S RISK.

Date and Revision

June 2004 Revision A

Part Number

973-0031-01-01 Rev A

Contact Information

Telephone: 1 800 670 0707 (toll free North America)
1 360 925 5097 (direct)

Fax: 1 800 994 7828 (toll free North America)
1 360 925 5143 (direct)

Email: customerservice@xantrex.com

Web: www.xantrex.com

About This Guide

Purpose

The purpose of this Owner’s Guide is to provide explanations and procedures for installing, operating, maintaining, and troubleshooting the Sine Wave Plus Long AC Conduit Box.

Scope

The Guide provides safety guidelines, and procedures for installing and operating the Sine Wave Plus Long AC Conduit Box.

Audience

The Guide is intended for a skilled electrician or technician who needs to install and operate the Sine Wave Plus Long AC Conduit Box. Installers should be certified and familiar with all local and national codes regarding electrical installations of this nature.

Organization

This Guide is organized into three chapters.

Chapter 1, “Introduction” provides a basic introduction to the design and purpose of the Sine Wave Plus Long AC Conduit Box (ACCB-L).

Chapter 2, “Installation” provides installation and wiring instructions for the Sine Wave Plus Long AC Conduit Box.

Chapter 3, “Operation” describes the different modes and operation of the AC Bypass Switch(es) on the ACCB-L-L1, or for the second AC Bypass Switch (ACCB-L-L2) if installed.

Warranty and product information is provided at the end of the guide.

Product Naming Conventions

ACCB-L refers to the Long AC Conduit Box without AC Bypass Switch.

ACCB-L-L1 refers to the Long AC Conduit Box with AC Bypass Switch.

ACCB-L-L2 refers to the ACCB-L-L1 with the field-installed ACCB-L2-PCK (AC Bypass Switch assembly, with wiring, and an AC Bus Bar for Hot L2 connections) and is usually configured for dual operation.

Long AC Conduit Box refers to all products and is used in situations where all three products are treated the same.

Conventions Used

The following conventions are used in this guide.



WARNING

Warnings identify conditions that could result in personal injury or loss of life.



CAUTION

Cautions identify conditions or practices that could result in damage to the unit or other equipment.

Important: These notes describe things which are important for you to know, but not as serious as a caution or warning.

Abbreviations and Acronyms

AC	Alternating Current
ACCB-L	AC Conduit Box Long (with ground bar only)
ACCB-L-L1	AC Conduit Box Long (adds internal components for wiring)
ACCB-L-L2	AC Conduit Box Long (built on ACCB-L-L1 for dual configuration)
ACCB-L2-PCK	AC Bypass Switch Assembly only (includes wiring)
ALM	Auxiliary Load Module
AHJ	Authority Having Jurisdiction
ASC	Authorized Service Center
AWG	American Wire Gauge
CEC	Canadian Electrical Code
CSA	Canadian Standards Association
DC	Direct Current
EPO	Emergency Power Off
GSM	Generator Start Module
ICA	Inverter Communications Adapter
ICM	Inverter Control Module
ISC-S	Inverter Stacking Control – Series
NEC	National Electrical Code
RMA	Return Material Authorization
UL	Underwriters Laboratory

Related Information

You can find more information about Xantrex Technology Inc. as well as its products and services at www.xantrex.com.

Important Safety Instructions



WARNING

This chapter contains important safety and operating instructions for the Sine Wave Plus Long AC Conduit Box (ACCB-L and ACCB-L-L1) and the ACCB-L-L2 (ACCB-L2-PCK add-on package). Read and keep this Sine Wave Plus AC Conduit Box Long Owner's Guide for future reference.

1. Before installing the Long AC Conduit Box, read all instructions and cautionary markings on the Long AC Conduit Box and all appropriate sections of this guide.
2. Do not expose the Long AC Conduit Box to rain, snow, or spray.
3. To reduce risk of fire hazard, do not cover or obstruct the ventilation openings.
4. Do not install the Long AC Conduit Box in a zero-clearance compartment. Overheating may result. *Minimum clearance for ventilation around the unit must be twelve inches above and around the sides of the unit. See "Ventilation Requirements" on page 2-5 for additional information.*
5. Do not store anything flammable near the unit. Relocate anything flammable to another location.
6. Xantrex offers CSA "approved" parts for installation into this product. Parts purchased elsewhere are subject to approval by the local electrical authority. See Figure 2-11 on page 2-16 for details.
7. The Long AC Conduit Box is designed to be permanently connected to your Sine Wave Plus inverter. Xantrex recommends that all wiring be done by a certified technician or electrician to ensure adherence to the local and national electrical codes applicable in your application.
8. To avoid a risk of fire and electric shock, make sure that existing wiring is in good condition and that wire is not undersized. Do not operate the Long AC Conduit Box, or inverter, with damaged or substandard wiring.
9. To reduce the risk of electrical shock, disconnect all power to the Long AC Conduit Box and the Sine Wave Plus Inverter/Charger before attempting any maintenance or cleaning or working on the Long AC Conduit Box.
10. The Long AC Conduit Box is provided with an equipment-grounding bar which must be connected to the inverter/system equipment ground.

Explosive gas precautions

1. Working in the vicinity of lead-acid batteries is dangerous. Batteries generate explosive gases during normal operation. Therefore, you must read this guide and follow the instructions exactly before installing the Long AC Conduit Box.
2. To reduce the risk of battery explosion, follow these instructions and those published by the battery manufacturer and the manufacturer of the equipment in which the battery is installed.

Certifications

CSA certified to the following standards:

- UL 1741-2001 (First Edition), and
- CSA C22.2 No. 107.1-01

Contents

Important Safety Instructions	v
--	---

1 Introduction

Introduction	1-2
Specifications	1-4
AC Bypass Switch Assembly	1-6
Blockoff Plates	1-7

2 Installation

Preparing for the Installation	2-2
Code Compliance	2-2
Installation Tools and Materials	2-2
Configuration Planning	2-3
Off-Grid Configurations	2-3
On-Grid Configurations	2-3
Pre-Installation	2-4
Location	2-4
Service Planning	2-4
Ventilation Requirements	2-5
Removing and Replacing the Cover	2-6
Installing or Removing the Blockoff Plates	2-7
Knockout Preparation	2-8
Installing Additional Breakers	2-10
Mounting	2-11
Mounting on the Xantrex Back Plate (XBP)	2-11
Mounting on Plywood	2-13
Wiring - General	2-14
Accessing the AC Input/Output Terminal Block in the ACCB-L-L1	2-14
Wire Sizes and Disconnect Requirements	2-15
Wiring for Off-Grid Applications	2-19
Single Inverter Configurations (120 Vac)	2-19
Step-down Configurations (240 Vac to 120 Vac)	2-21
Step-up Configuration (Deep Well Pump) (120 Vac to 240 Vac)	2-23
Dual Inverter Configurations (120 Vac and 240 Vac)	2-24
Wiring for On-Grid Applications	2-25
Single Inverter Configurations (120 Vac)	2-25
Step-up Configurations (Utility Backup) (120 Vac to 240 Vac)	2-27
Dual Inverter Configurations (120 Vac and 240 Vac)	2-28
Additional Accessory Wiring	2-29

3 Operation

The AC Bypass Switch ----- 3-2
Operating the AC Bypass Switch ----- 3-2
 Normal Operation ----- 3-3
 Bypass Operation ----- 3-3
 AC Input/Output Off ----- 3-4
Dual Inverters: 240 Vac Loads ----- 3-4

Warranty and Return Information ----- WA-1

Index ----- IX-1

Figures

Figure 1-1	The Sine Wave Plus ACCB-L Basic-----	1-2
Figure 1-2	The Sine Wave Plus Long AC Conduit Box (ACCB-L-L1, and ACCB-L-L2)-----	1-3
Figure 1-3	ACCB-L Dimensions (not to scale) -----	1-5
Figure 1-4	Bypass Switch Assembly in the ACCB-L-L1-----	1-6
Figure 1-5	Blockoff Plates -----	1-7
Figure 2-1	Shock Hazard Warning Label -----	2-4
Figure 2-2	Clearance Requirements for Ventilation -----	2-5
Figure 2-3	Cover Removal and Replacement -----	2-6
Figure 2-4	The Blockoff Plate on the Long AC Conduit Box-----	2-7
Figure 2-5	SW Plus Inverter, AC Side Showing Knockout Location-----	2-8
Figure 2-6	Knockouts Locations -----	2-9
Figure 2-7	Installing Additional Breakers on the DIN Rail -----	2-10
Figure 2-8	The Xantrex Back Plate -----	2-11
Figure 2-9	Installing the ACCB-L on the Backplate-----	2-12
Figure 2-10	Installing the ACCB-L to the SW Plus Inverter on Plywood-----	2-13
Figure 2-11	ACCB-L Approved Internal Components -----	2-16
Figure 2-12	ACCB-L-L1 Internal Components (Factory installed)-----	2-17
Figure 2-13	ACCB-L-L1 Internal Components with the Optional ACCB-L2-PKG Installed -----	2-18
Figure 2-14	Wiring an Off-grid Application Using a Single Inverter -----	2-19
Figure 2-15	Wiring an Off-grid Application Using a Single Inverter (No Sub Panel) -----	2-20
Figure 2-16	Wiring an Off-grid Application Using a Single Inverter and TX Autotransformer in a Step-Down Configuration-----	2-21
Figure 2-17	Wiring an Off-grid Application Using a Single Inverter and TX Autotransformer for a Step-Down Configuration (No Sub Panel) -----	2-22
Figure 2-18	Wiring an Off-grid Application Using a Single Inverter and TX Autotransformer for a Step-Up Configuration for a Deep Well Pump Application-----	2-23
Figure 2-19	Wiring an Off-grid Application Using Dual Inverters (ACCB-L-L2)-----	2-24
Figure 2-20	Wiring an On-grid Application Using a Single Inverter-----	2-25
Figure 2-21	Wiring an On-grid Application Using a Single Inverter (No Sub Panel)-----	2-26
Figure 2-22	Wiring an On-grid Application Using a Single Inverter and TX Autotransformer for a Step-Up Configuration for Utility Backup -----	2-27
Figure 2-23	Wiring an On-grid Application Using Dual Inverters (ACCB-L-L2) -----	2-28
Figure 2-24	Accessory Wiring for Single-Inverter Configurations -----	2-29
Figure 2-25	Accessory Wiring for Dual-Inverter Configurations -----	2-30
Figure 3-1	AC Bypass Switch Mode Summary -----	3-2
Figure 3-2	Normal Operation -----	3-3
Figure 3-3	Bypass Operation -----	3-3
Figure 3-4	AC Output OFF -----	3-4

Tables

Table 1-1	Operational and Environmental Specifications for the ACCB-L, ACCB-L-L1, and ACCB-L-L2 -----	1-4
Table 2-1	Torque Values for Wiring-----	2-15

1

Introduction

Chapter 1, “Introduction” provides a basic introduction to the design and purpose of the Sine Wave Plus Long AC Conduit Box (ACCB-L).

The following topics are covered in this chapter.

For this topic:	See:
“Introduction”	page 1–2
“Specifications”	page 1–4
“AC Bypass Switch Assembly”	page 1–6

Introduction

The Sine Wave Plus Long AC Conduit Box (ACCB-L and ACCB-L-L1) connects to the AC side of a Sine Wave Plus inverter and accepts AC conduit runs. It is designed to protect the wiring connections to the inverter and provides room for up to nine additional AC disconnect breakers (Square D, Type QOU, DIN rail mounted) to protect user-specified loads.

There are three models of ACCB-L:

- the ACCB-L Basic,
- the ACCB-L-L1, and
- the ACCB-L-L2.

The ACCB-L contains a ground bar only and provides no wiring.

The ACCB-L-L1 includes a ground wire attached to the ground bar, an AC bypass switch (for a single AC input source) and input/output wiring attached to the AC Input/output Terminals, a Neutral bar with neutral wire installed, and an isolated HOT bar.

The ACCB-L-L2 configuration is created by field-intalling an ACCB-L2-PCK into an ACCB-L-L1. The ACCB-L2-PCK consists of another field-installable AC Bypass Switch with wiring and an isolated AC Bus Bar.

This guide provides instructions for connecting the Long AC Conduit Box to the inverter and other system components (i.e., utility panel, AC distribution panel, grounding, and generator). It also provides instructions for installing additional Square D™, Type QOU, DIN rail-mounted circuit breakers.

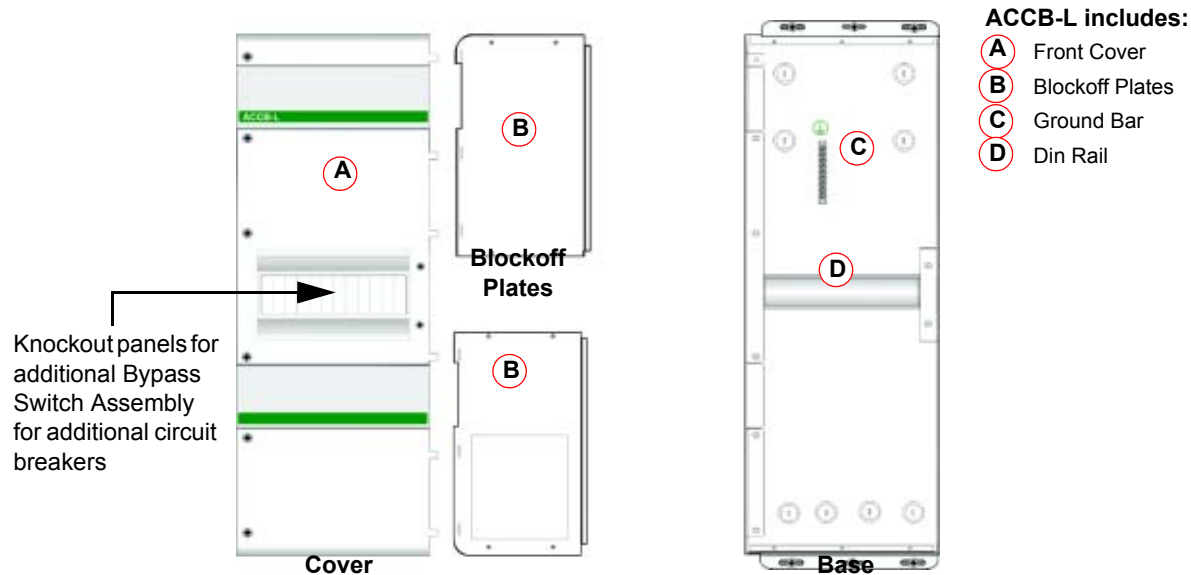
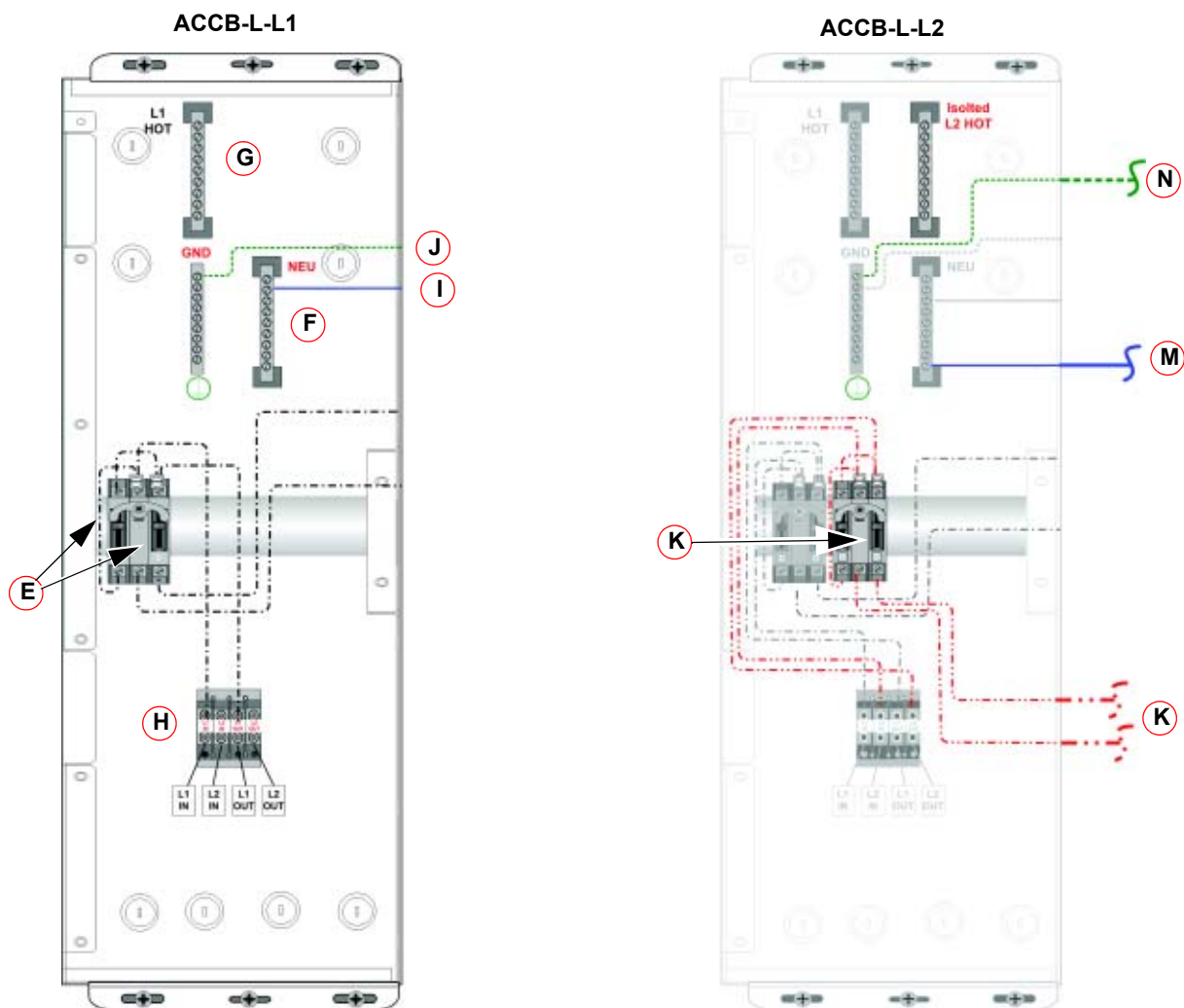

Figure 1-1 The Sine Wave Plus ACCB-L Basic



ACCB-L-L1 includes the components of the ACCB-L and adds the following:

- (E)** One AC Bypass Switch Assembly (including wiring)
- (F)** AC Bus Bar (Neutral)
- (G)** AC Bus Bar (HOT L1)
- (H)** AC Input/output Terminal Block
- (I)** One length white NEUTRAL wire
- (J)** One length green GROUND wire

ACCB-L-L2 is created by installing the ACCB-L2-PCK to the ACCB-L-L1. ACCB-L2-PCK consists of the following:

- (K)** Second AC Bypass Switch Assembly Only (including wiring)
- (L)** AC Bus Bar (HOT L2)
- (M)** One length white NEUTRAL wire
- (N)** One length green GROUND wire

*This package is field-installed. The illustration above shows where it would be located when installed in the ACCB-L-L1.

Figure 1-2 The Sine Wave Plus Long AC Conduit Box (ACCB-L-L1, and ACCB-L-L2)

Specifications

The following table contains the specifications for the ACCB-L, the ACCB-L-L1, and the ACCB-L-L2. The ACCB-L-L2 is not available pre-built from the factory, but is created by field-installing an ACCB-L2-PCK into a ACCB-L-L1 model.

Table 1-1 Operational and Environmental Specifications for the ACCB-L, ACCB-L-L1, and ACCB-L-L2

	ACCB-L	ACCB-L-L1	ACCB-L-L2 ^a
Dimensions	33" (H) x 11" (W) x 8 3/4" (D) (84 cm x 28 cm x 23 cm)	33" (H) x 11" (W) x 8 3/4" (D) (84 cm x 28 cm x 23 cm)	<i>This configuration is created by field-installing an ACCB-L2-PCK into an ACCB-L-L1.</i>
Weight	19 pounds (8.6 kg)	24 pounds (10.9 kg)	~2 pounds
Shipping Weight	23 pounds (10.4 kg)	27 pounds (12.2 kg)	~2 pounds
Operating Voltage	120/240 Vac, 60 Hz split-phase	120/240 Vac, 60 Hz split-phase	120/240 Vac, 60 Hz split-phase
Factory-installed hardware	<ul style="list-style-type: none"> • Din Rail • Ground Bar 	<ul style="list-style-type: none"> • Din Rail • Ground Bar • AC Bus Bar (Neutral) • AC Bus Bar (HOT L1) • AC Input/Output Terminals • AC Bypass Breaker 	<ul style="list-style-type: none"> • Din Rail • Ground Bar • AC Bus Bar (Neutral) • AC Bus Bar (HOT L1) • AC Input/Output Terminals • AC Bypass Breaker
Factory-installed wiring	None	#6 THHN AWG, rated to 105 °C, stranded copper <ul style="list-style-type: none"> • One - Ground Wire • One - Neutral Wire • One - HOT IN • One - HOT OUT 	#6 THHN AWG, rated to 105 °C, stranded copper <ul style="list-style-type: none"> • One - Ground Wire • One - Neutral Wire • One - HOT IN • One - HOT OUT
Field-installed hardware	N/A	ACCB-L2-PCK (needed to create ACCB-L-L2)	<ul style="list-style-type: none"> • AC Bypass Breaker (Din Rail-mountable) (w/HOT In and HOT Out wiring) • AC Bus Bar (HOT L2)
AC Bypass Switch			
Bypass	None	60 Amp (SPST)	60 Amp (SPST)
Inverter Input/Output	None	60 Amp (DPST)	60 Amp (DPST)
Rated Temperature	0 to 25 °C (32 to 77 °F)	0 to 25 °C (32 to 77 °F)	0 to 25 °C (32 to 77 °F)
Storage Temperature	-55 to +100 °C (-67 to 212 °F)	-55 to +100 °C (-67 to 212 °F)	-55 to +100 °C (-67 to 212 °F)
Enclosure	Indoor rated, White, Powdercoat Finish	Indoor rated, White, Powdercoat Finish	Indoor rated, White, Powdercoat Finish

Table 1-1 Operational and Environmental Specifications for the ACCB-L, ACCB-L-L1, and ACCB-L-L2

	ACCB-L	ACCB-L-L1	ACCB-L-L2 ^a
Ratings	120/240 Vac/60 hz., split-phase, 60 Amp pass-thru	120/240 Vac/60 hz., split-phase, 60 Amp pass-thru	120/240 Vac/60 hz., split-phase, 60 Amp pass-thru
Regulatory	Certified by CSA to UL 1741-2001 (First Edition) and CSA C22.2 No. 107.1-01	Certified by CSA to UL 1741-2001 (First Edition) and CSA C22.2 No. 107.1-01	Certified by CSA to UL 1741-2001 (First Edition) and CSA C22.2 No. 107.1-01

a. The ACCB-L-L2 is not available pre-built from the factory, but is created by field-installing an ACCB-L2-PCK into a ACCB-L-L1 model.

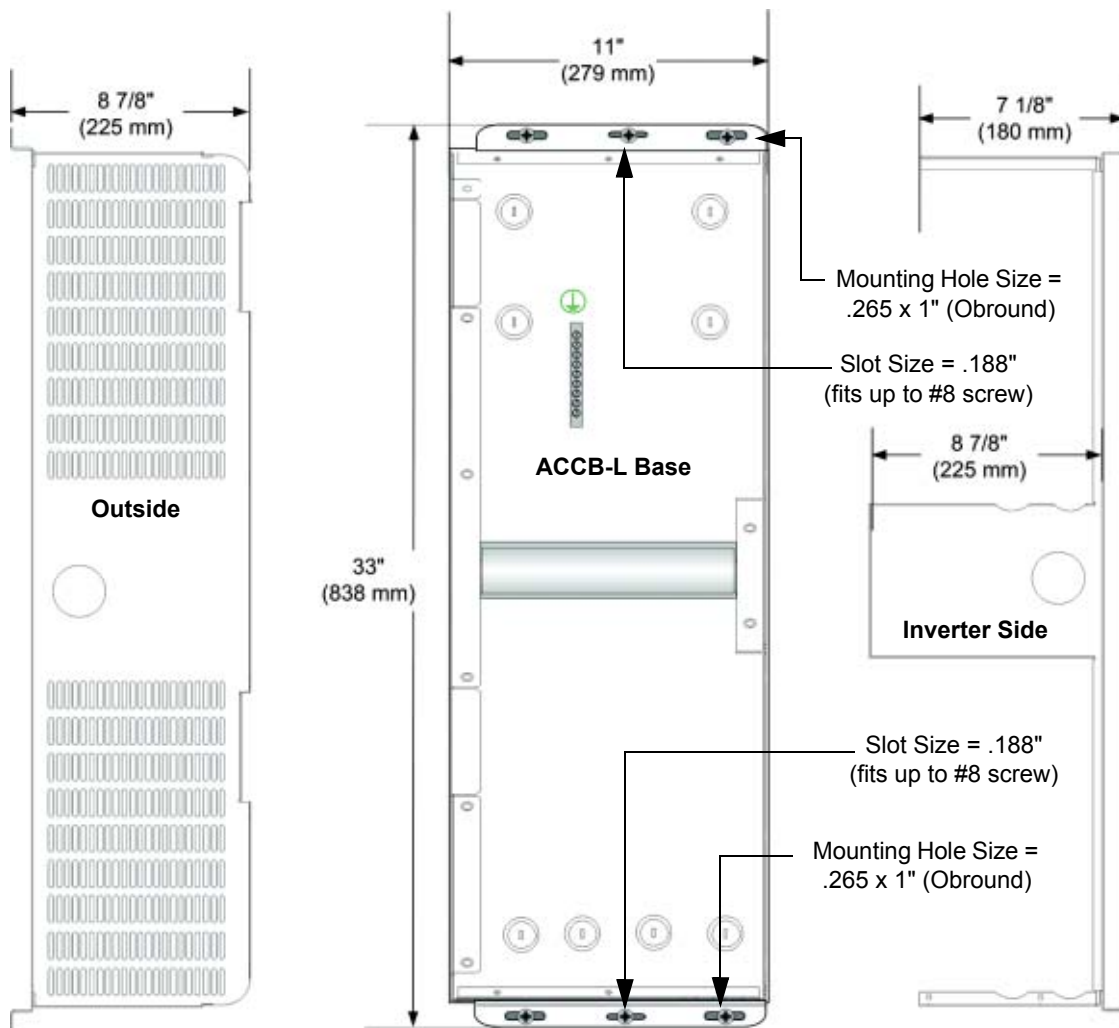

Figure 1-3 ACCB-L Dimensions (not to scale)

AC Bypass Switch Assembly

The AC bypass switch assembly in the ACCB-L-L1 is designed for 120 Vac applications and comes with two 60-amp circuit breakers (one SPST and one DPST). The breaker pair is equipped with a lockout rocker that allows only one breaker to be ON at any given time.

The AC bypass switch allows the generator or grid to provide power to the inverter loads in the event that the inverter is disabled for battery maintenance or removed for service.

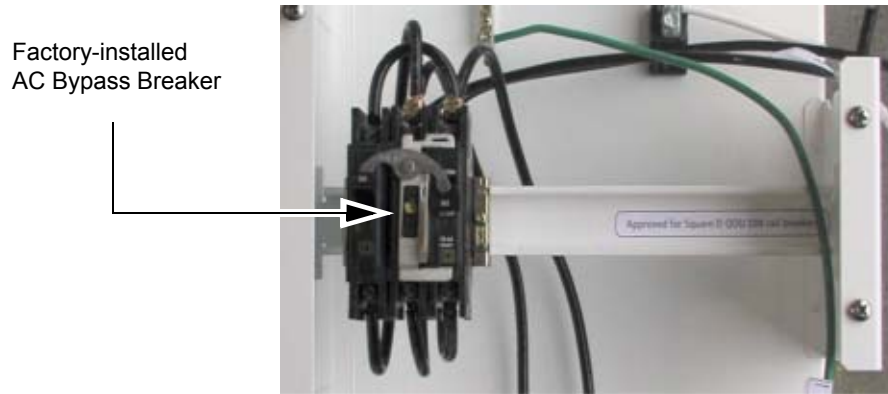

Figure 1-4 Bypass Switch Assembly in the ACCB-L-L1

A second AC bypass switch assembly (ACCB-L2-PCK) is available for dual-inverter installations (ACCB-L-L2 configuration). This field-installed, add-on package includes pre-cut wires for wiring a second inverter in the lower position and provides an additional Isolated Hot Bar for optional installation.



CAUTION: Equipment Damage

Although it is possible to use the second AC Bypass Switch for a second AC input (i.e., generator and grid) to the same inverter, using the AC Bypass Switch for this purpose is not recommended. Switching ON both Bypass switches can cause the two AC sources to short each other out.

For more information see Chapter 3, “Operation” in this guide.



WARNING: Electrical Hazard

If the inverter is removed from service while the bypass is used, live circuits inside the Long AC Conduit Box will not be guarded from accidental contact. Be sure to install the Blockoff Plates to prevent accidental electrocution if the inverter is removed from the system.

Blockoff Plates

Upper and Lower Blockoff Plates are included to enclose the open portions of the Long AC Conduit Box chassis. In the event that an inverter is removed for service, the Blockoff Plates secure the enclosure to prevent accidental contact with any AC power within the Long AC Conduit Box.

Remove the Blockoff Plate (upper or lower) from its position for the inverter used in your installation. The Blockoff Plates will not be needed at all in a dual SW Plus inverter installation.

See page 2-7 for installation instructions for the Blockoff Plates.

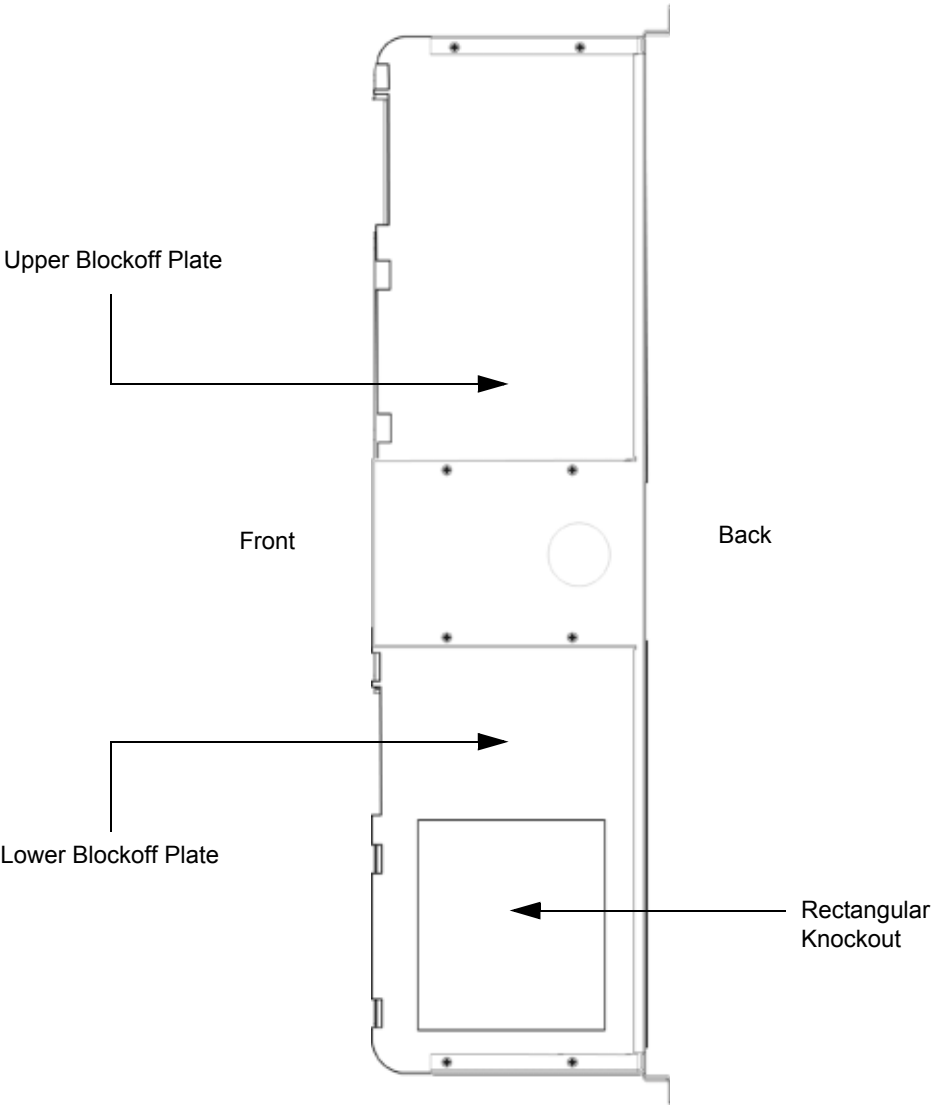

Figure 1-5 Blockoff Plates

2

Installation

Chapter 2, “Installation” provides installation and wiring instructions for the Sine Wave Plus Long AC Conduit Box.

The following topics are covered in this chapter.

For this topic:	See:
“Preparing for the Installation”	page 2-2
“Configuration Planning”	page 2-3
“Installing or Removing the Blockoff Plates”	page 2-7
“Mounting”	page 2-11
“Wiring - General”	page 2-14
“Wiring for Off-Grid Applications”	page 2-19
“Wiring for On-Grid Applications”	page 2-25
“Additional Accessory Wiring”	page 2-29

Preparing for the Installation

Important: Before installing the Long AC Conduit Box, read all instructions and cautionary markings located in this guide and in your inverter manual.

Code Compliance

Governing installation codes vary depending on the location and type of installation. Electrical installations must meet local and national wiring codes. Installations of this equipment should only be performed by skilled personnel such as qualified electricians and Certified Renewable Energy (RE) System Installers. For a list of Xantrex Certified RE dealers, please visit our website at www.XantrexREdealers.com.

Important: Be sure to obtain the appropriate permits, if necessary, prior to starting this installation.

Installation Tools and Materials

Tools Required

The following tools may be required for installing this equipment:

- Wire strippers
- Assorted open-end wrenches or socket wrench and fittings
- Torque wrench
- Electrical tape
- Multimeter (AC/DC volts, frequency)
- Assorted Phillips screw drivers
- Allen/Hex head driver set
- Slotted screw driver
- Level
- Pencil
- Utility knife

Hardware / Materials Required

The following materials may be required for completing this installation:

- Conduits (flexible conduit is recommended), bushings, wire nuts, and appropriate fittings for wire runs
- Electrical wire of appropriate size and length
- Breaker panels (if used)
- Additional circuit breakers (if required)
- Ground busses, bars, and/or rods
- Six appropriately sized wood screws or lag bolts and washers

Configuration Planning

Wiring scenarios will depend upon the configuration of the overall system (i.e., Off Grid or On Grid, and output requirements).

Pre-installation and mounting instructions apply to all configurations. Follow the instructions from page 2–4 to page 2–19 for all installations.

After the pre-installation procedures have been completed, select the wiring scenario that applies to your configuration. Once you have completed the wiring instructions for your specific application, proceed to the Operation section.

Off-Grid Configurations

The following Off-Grid scenarios are covered in this guide:

- **Single inverter (120 Vac)**
See Figure 2-14 on page 2–19 for a wiring diagram for this application.
See Figure 2-15 on page 2–20 for a wiring diagram for this application using the Long AC Conduit Box as a sub panel.
- **Single inverter and a TX Autotransformer for a Step-down application (240 Vac to 120 Vac)**
See Figure 2-16 on page 2–21 for a wiring diagram for this application.
See Figure 2-17 on page 2–22 for a wiring diagram for this application using the Long AC Conduit Box as a sub panel.
- **Single inverter and a TX Autotransformer for a Step-up application (120 Vac to 240 Vac with Water Pressure Switch) for Deep Well Pump Applications**
See Figure 2-18 on page 2–23 for a wiring diagram for this application.
- **Dual inverters**
See Figure 2-19 on page 2–24 for a wiring diagram for this application.

On-Grid Configurations

The following On-Grid scenarios are covered in this guide:

- **Single inverter**
See Figure 2-20 on page 2–25 for a wiring diagram for this application.
- **Single inverter and a TX Autotransformer for a Step-up application**
See Figure 2-22 on page 2–27 for a wiring diagram for this application.
- **Dual inverters**
See Figure 2-23 on page 2–28 for a wiring diagram for this application.

Pre-Installation



WARNING: Shock Hazard

Ensure that no DC voltage is being supplied to the inverter and that no AC voltage is present on the AC wiring. Failure to do so could cause serious injury or death. A warning label is provided to inform all personnel that multiple sources of power are available inside. This label should be installed on the outside cover to be clearly visible. Ensure all sources are **OFF** or disconnected **before** servicing.

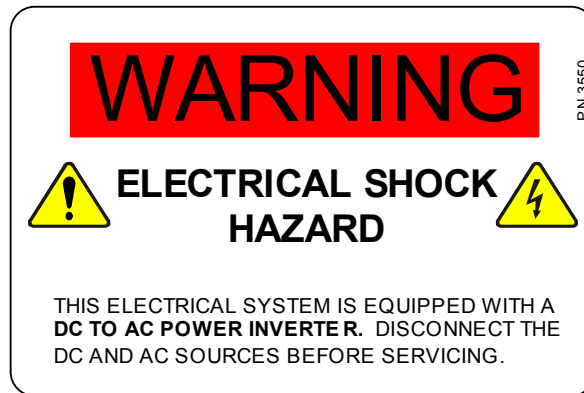

Figure 2-1 Shock Hazard Warning Label

Location

Be sure to allow sufficient space for the Long AC Conduit Box to be mounted directly adjacent to the inverter's AC side. Be sure to leave room for expansion if necessary. Also consider the additional weight and ventilation space requirements of the Long AC Conduit Box.

Service Planning

If for any reason the inverter may need service or needs to be removed from the position where it's mounted, the following recommendations should be considered to make this task easier.

To make servicing the inverter easier to accomplish:

- Use flexible conduit.
- When mounting the components such as the ACCB-L or DCCB-L next to the inverter, bias the mounting screws away from the inverter. This will allow "sliding" room within the mounting holes, so that the ends can slide apart without being removed from their mounted position.

Figure 2-10, "Installing the ACCB-L to the SW Plus Inverter on Plywood" on page 2-13 for details.

Ventilation Requirements

Minimum clearance for ventilation around the Long AC Conduit Box must be at least 12 inches (305 mm) at the top, the ends, and in front. This clearance is needed to prevent recirculating hot air from the inverter's exhaust (DC side) from going back into the inverter's intake (AC side).

Please refer to the Sine Wave Plus Inverter/Charger Owner's Guide for additional location considerations.

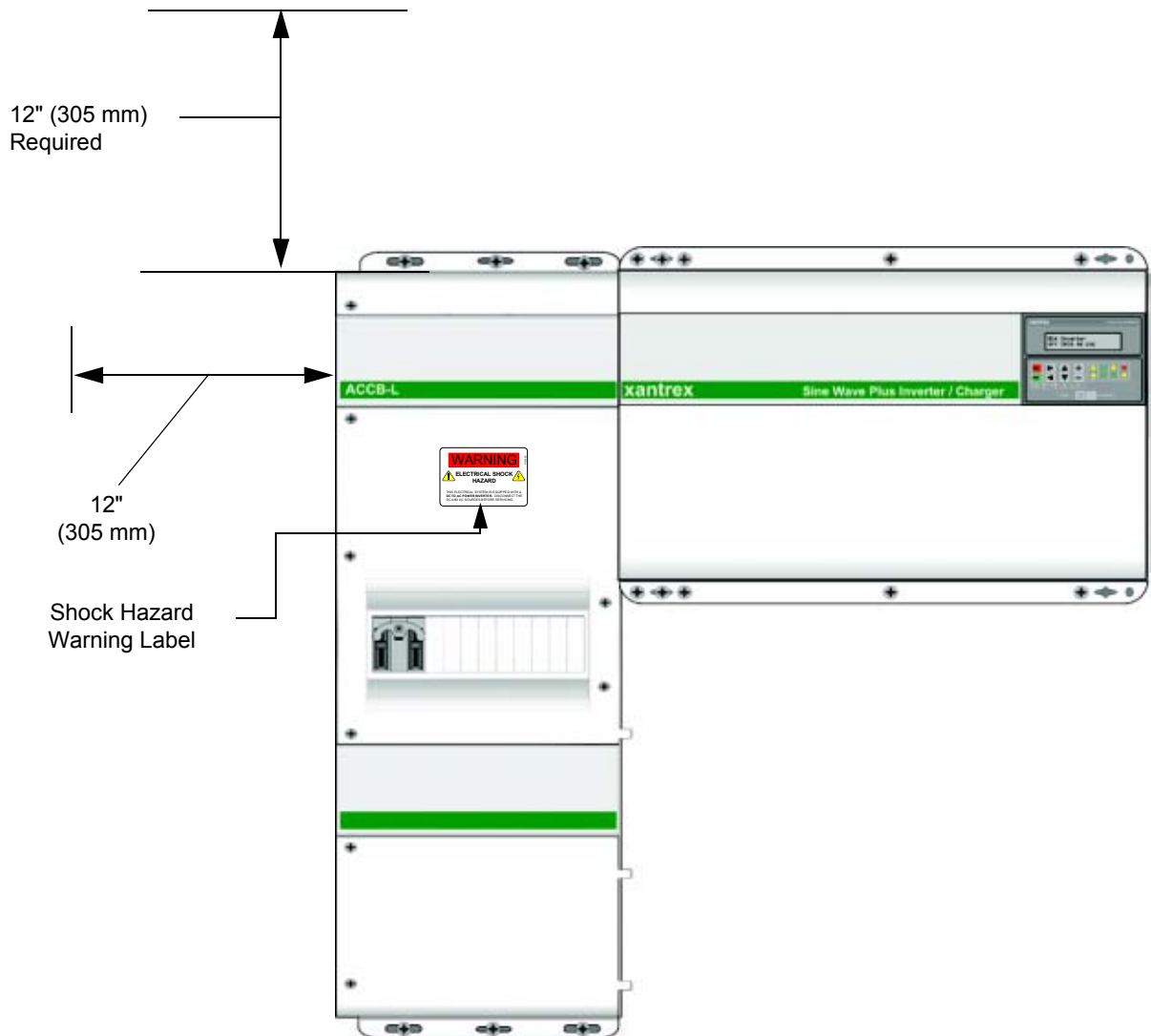

Figure 2-2 Clearance Requirements for Ventilation

Removing and Replacing the Cover

Remove the top cover to install additional breakers and to connect the AC wiring of the Long AC Conduit Box to the Sine Wave Plus Inverter. Follow the diagram below to locate and remove, or replace, the appropriate screws and washers on the cover of the Long AC Conduit Box. Be sure to put the screws in a safe place when removed, so they don't get lost. Torque to the values provided in Figure 2-3 when replacing them.

Remove these 3 #8 phillips screws from the top of the cover.

When replacing these #8 phillips screws, torque to 19-21 in-lb.

Remove these 8 #12 phillips screws from the front of the cover.

When replacing these #12 phillips screws, torque to 26-28 in-lb.

Remove these 3 #8 phillips screws from the bottom of the cover.

When replacing these #8 phillips screws, torque to 19-21 in-lb.

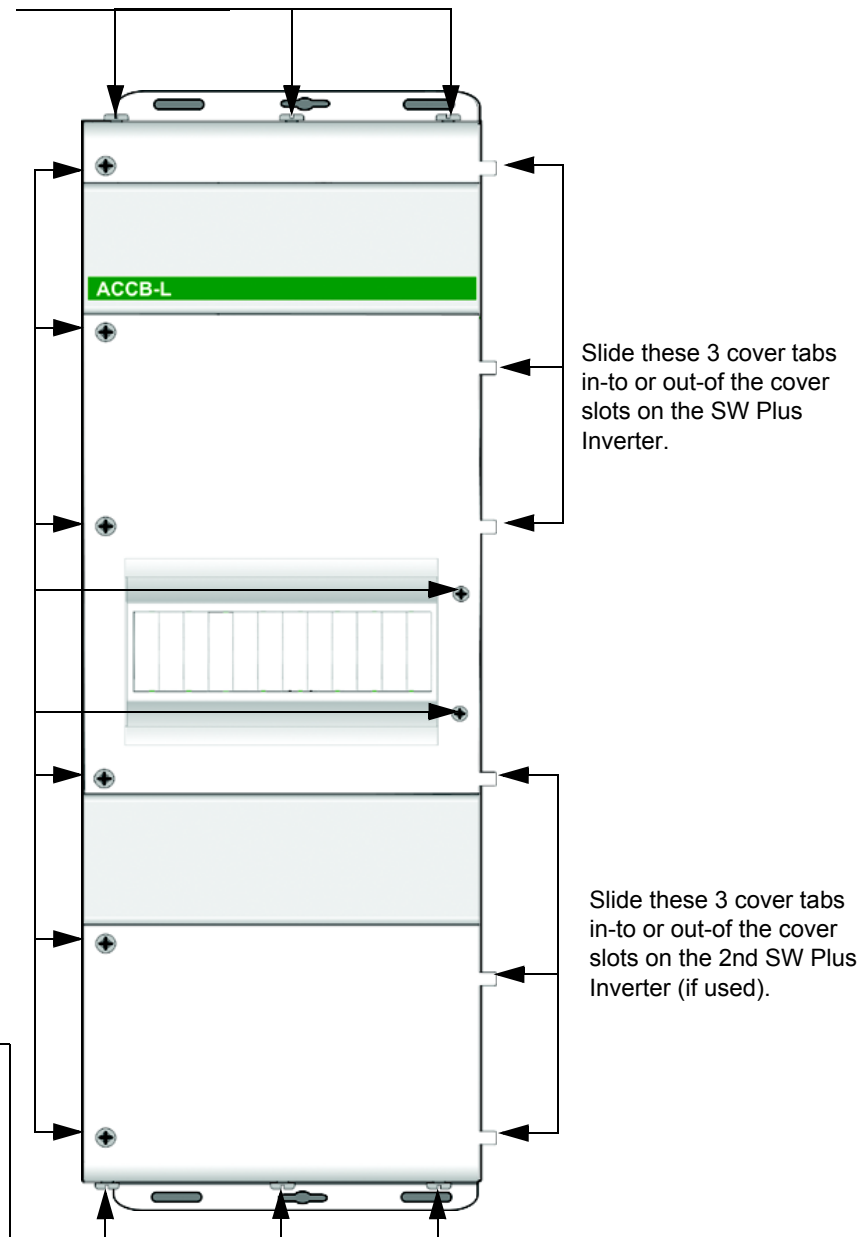

Slide these 3 cover tabs in-to or out-of the cover slots on the SW Plus Inverter.

Slide these 3 cover tabs in-to or out-of the cover slots on the 2nd SW Plus Inverter (if used).

Figure 2-3 Cover Removal and Replacement

Installing or Removing the Blockoff Plates

The unit is shipped with both upper and lower blockoff plates installed. If you are installing a single-inverter system, remove the upper blockoff plate only. If you are installing a dual-inverter system, then remove the lower blockoff plate also.

If a TX Autotransformer is to be installed in the lower position, remove the rectangular knockout in the lower blockoff plate. Do not remove the lower blockoff plate from that position.

Store the unused blockoff plates in a safe place, where they can be easily retrieved and reinstalled in the event that the inverter is removed for service.



WARNING: Shock Hazard

Be sure to disconnect all DC and AC power before removing the inverter and installing the blockoff plates.

Align the holes on the Blockoff Plate *behind* the holes provided from the inside of the ACCB-L chassis.

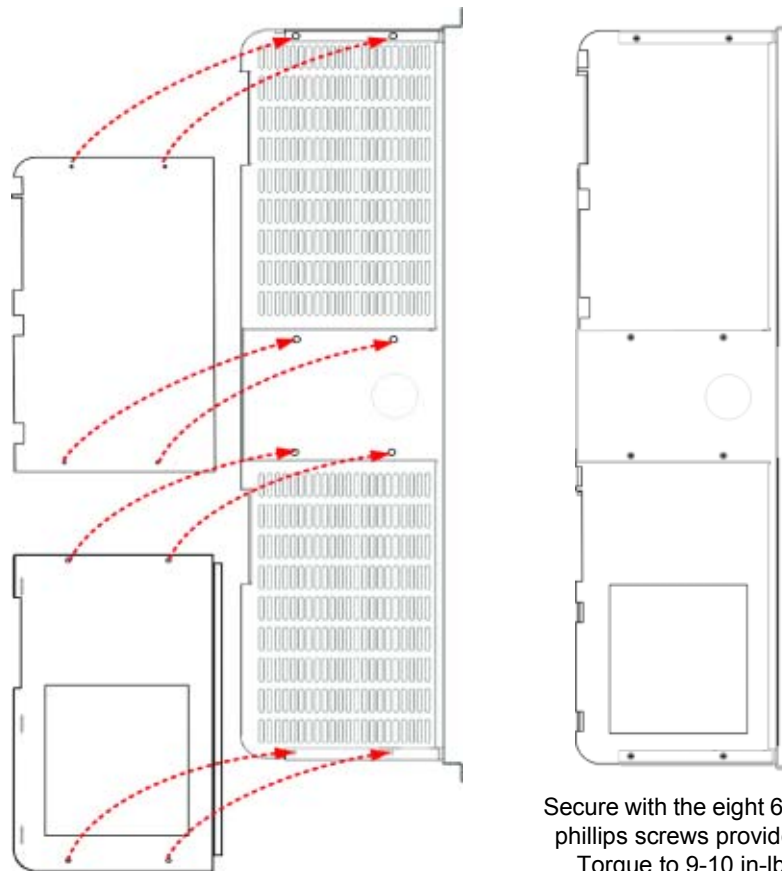

Secure with the eight 6x32 phillips screws provided.
Torque to 9-10 in-lb.

Figure 2-4 The Blockoff Plate on the Long AC Conduit Box

Knockout Preparation

Knockout preparation should be done before mounting either the inverter or the Long AC Conduit Box.

1. Remove the appropriate knockouts from the AC side of the inverter for cabling from the Long AC Conduit Box terminal block to the inverter terminal block. See Figure 2-5 for the size and locations of the knockouts on the Sine Wave Plus Inverter Charger.
2. Remove the appropriate knockouts from the Long AC Conduit Box for wire runs from utility and/or inverter panels, a generator, and/or additional inverters. See Figure 2-6 for the locations of the knockouts on the Long AC Conduit Box.
3. If additional circuit breakers are to be added to the Long AC Conduit Box, remove one knockout on the top cover for each additional circuit breaker to be installed. See Figure 2-6 for the locations of the knockouts on the Long AC Conduit Box top cover.
4. Ensure that there are no metal shavings in the Long AC Conduit Box or inverter before proceeding with the rest of the installation.
5. Install bushings in the knockout holes to protect the wires from damage.

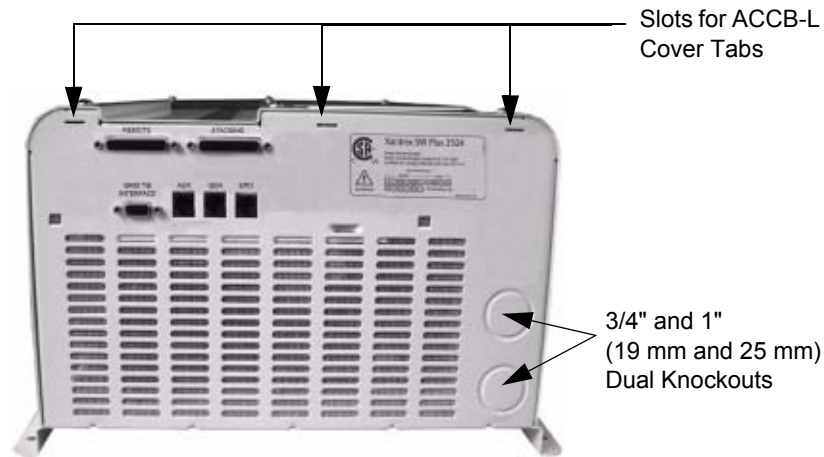

Figure 2-5 SW Plus Inverter, AC Side Showing Knockout Location

Important: If larger knockouts are required in the Long AC Conduit Box, an electricians knockout punch may be used for larger size knockout holes if necessary.

Square D™ filler plates (QOFP) may be used to refill a knockout panel if the knockout is no longer used or removed in error.

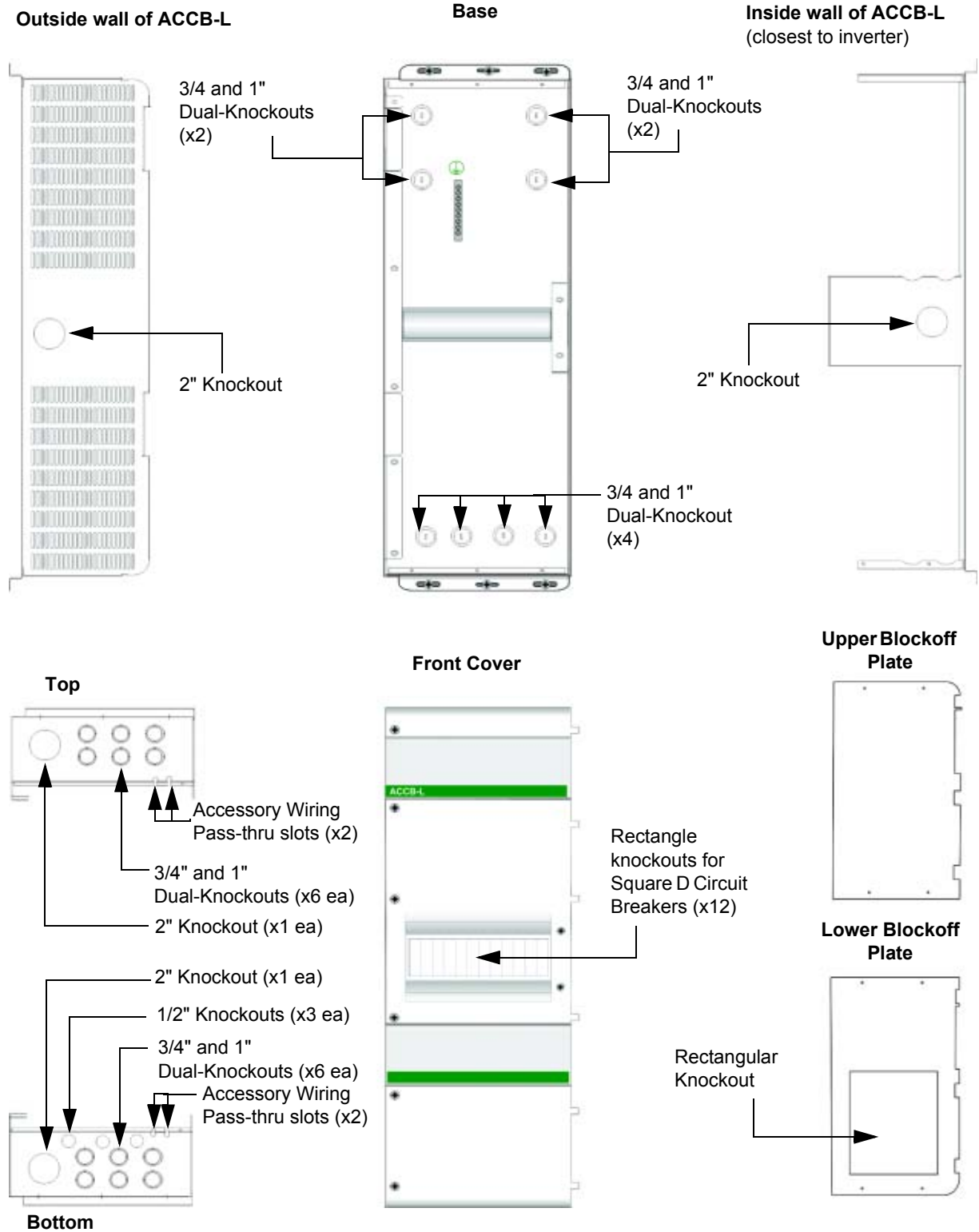

Figure 2-6 Knockouts Locations

Installing Additional Breakers

If additional AC circuit breakers are to be installed for specific AC loads or a generator disconnect, then install them per the manufacturer's instructions on the DIN Rail in the space to the left of the factory-installed AC Bypass Breaker. The Long AC Conduit Box DIN Rail supports Square-D™, Type QOU, circuit breakers.

To install additional Square-D™, Type QOU, circuit breakers in the Long AC Conduit Box:

1. Remove the top cover as described on page 2–6.
2. Loosen the screw in the DIN Rail End Clamp and slide the clamp away from the existing breaker.
3. Install the circuit breaker(s) on the DIN Rail to the right of the factory-installed AC Bypass Switch. Be sure to align them to fit into the spaces made by the knockouts that were removed on the top cover.
4. Slide the clamp tight against the last circuit breaker on the right and tighten the screw to secure the clamp on the DIN Rail.

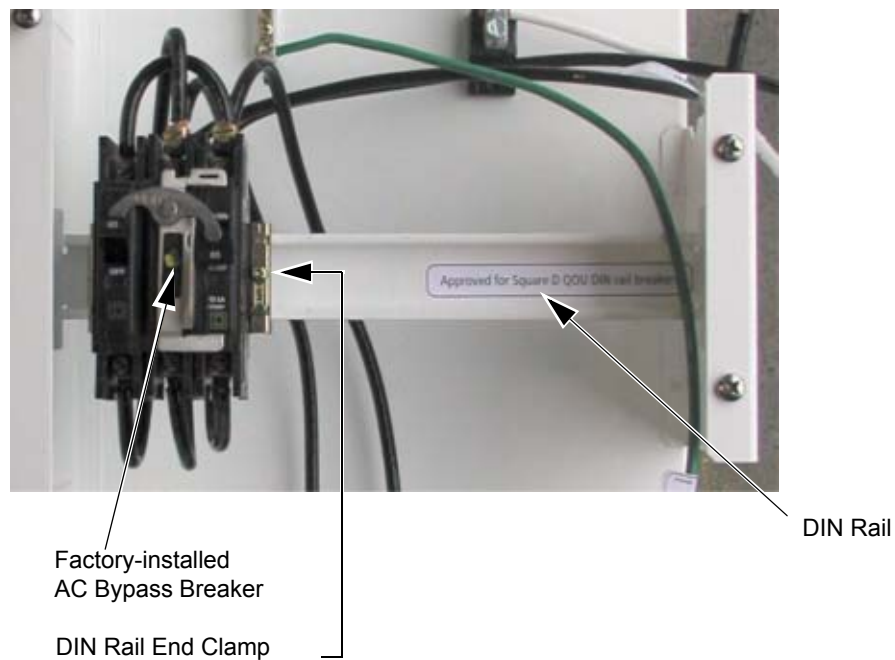

Figure 2-7 Installing Additional Breakers on the DIN Rail

If creating an ACCB-L-L2 using the ACCB-L2-PCK add-on package, install the second AC Bypass Switch to the right of the factory-installed AC Bypass Switch. See the instructions provided with the package. Ensure the DIN Rail End clamp is tight against the last breaker installed.

Mounting

The Long AC Conduit Box is designed to mount directly to the AC side of a Sine Wave Plus inverter. However, the SW Plus inverter can weigh up to 136 pounds (62 kg). The ACCB-L weighs up to 27 lbs (12.2 kg). Ensure the supporting surface is strong enough to hold twice the total weight being installed. Remember to include the weight of any other accessory, such as the DC Conduit Box, when considering the strength of the supporting surface.

Xantrex provides a steel back plate (XBP) that provides the additional support. A sheet of 3/4" plywood could also provide adequate support.

Mounting on the Xantrex Back Plate (XBP)

A two-piece, steel back plate is available for providing extra support to the mounting surface. The back plate comes with mounting hooks that can be attached to the panel to hang the components on as they're installed.

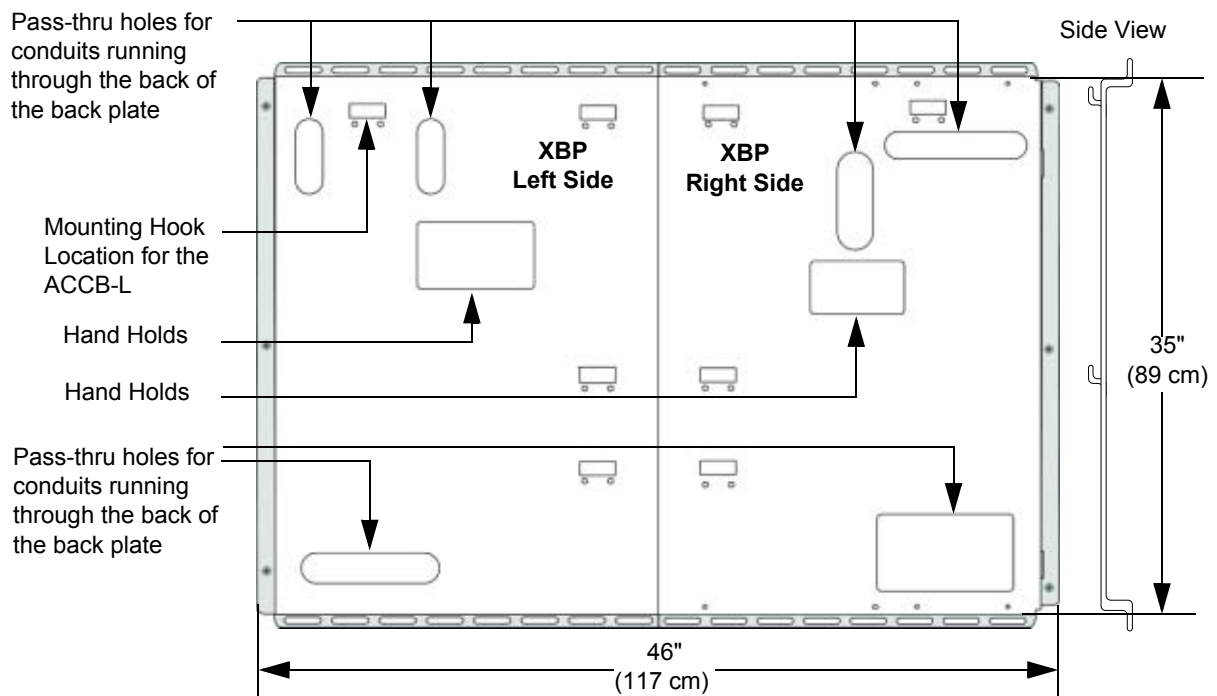

Figure 2-8 The Xantrex Back Plate

To mount the Long AC Conduit Box on the Back Plate (XBP):

1. Install the mounting hook (if used) onto the backplate in the position indicated in Figure 2-8 for the Long AC Conduit Box. See the XBP Installation Instructions for details.
2. Mount the backplate to the supporting surface according to the instructions provided with the XBP Installation Instructions.

3. Lift the inverter and place the mounting holes in the rail directly over the mounting hooks on the panel and lower into place.
4. Install four ¼-20 phillips screws provided with the panel, into the mounting holes of the Long AC Conduit Box, but do not fully tighten.
5. Lift the second inverter (if used) and place the mounting holes in the rail directly over the mounting hooks on the panel and lower into place.
6. Install four ¼-20 phillips screws on the second inverter (if used) into the mounting holes of the Long AC Conduit Box, but do not fully tighten.
7. Next, lift the Long AC Conduit Box and place the mounting hole in the rail directly over the mounting hooks on the panel and lower into place.

Important: Ensure the mounting hooks are visible through the holes in the mounting rails. If you can not see the hooks, the unit is not installed properly and will not be secure to the wall.

8. Push the Long AC Conduit Box as close to the inverter(s) as it will possibly go and secure it to the panel using four of the ¼-20 phillips screws provided with the back plate hard ware kit. Torque to 76 in-lbs.
9. Tighten the mounting screws on the inverter(s) to the panel. Torque to 76 in-lbs.

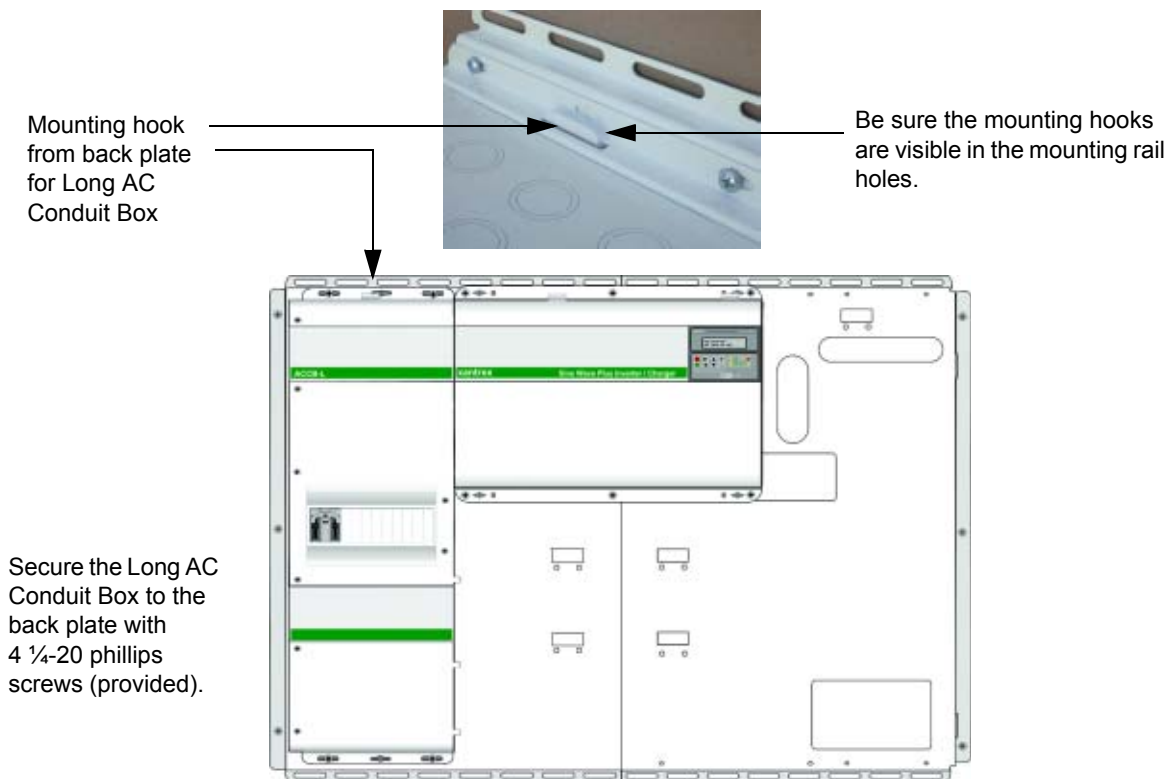

Figure 2-9 Installing the ACCB-L on the Backplate

Mounting on Plywood

Important: Ensure that the factory-installed cables in the Long AC Conduit Box are not pinched, crushed, removed, or damaged during the installation to the inverter.

To mount the Long AC Conduit Box on plywood:

1. With the help of another person, lift the inverter and mount it into place. Secure it to the plywood with #10 wood screws (14 total - length to penetrate 1½ inches or more into the studs.) *See the Sine Wave Plus Inverter/Charger Owner's Manual for more specific mounting instructions for the inverter.*
2. Line up the Long AC Conduit Box at the AC end of the inverter, so that the mounting rails are aligned together and the Long AC Conduit Box base is as close to the inverter as possible. The gap between the Long AC Conduit Box and the inverter should be no more than 1/16 inch.
3. Secure the Long AC Conduit Box in place with six #10 wood screws of an appropriate length (or lag bolts) in the six mounting and keyhole slots on the mounting rails of the ACCB. Bias the screws away from the inverter.
4. Leave the top cover off the Long AC Conduit Box to proceed with wire connections.

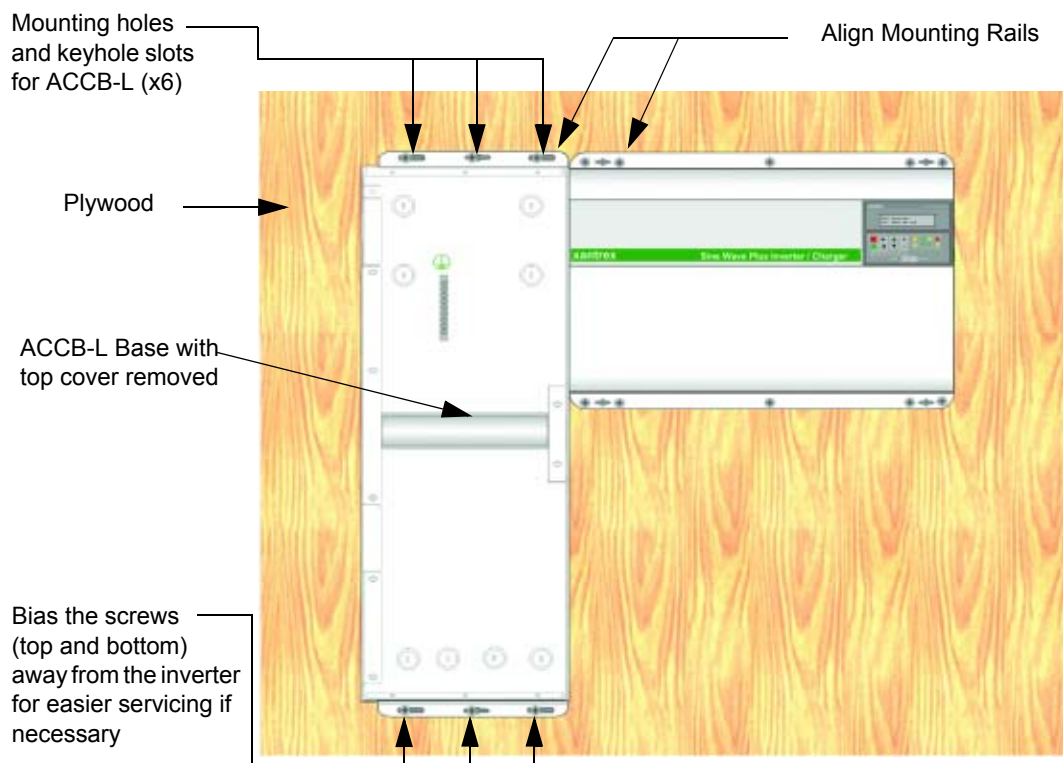

Figure 2-10 Installing the ACCB-L to the SW Plus Inverter on Plywood

Wiring - General

The ACCB-L comes with a ground bar only. The ACCB-L-L1 is pre-wired at the factory and ready for connection to one Sine Wave Plus Inverter/Charger. The factory-installed wires are labeled to assist with the installation procedure.

See Figure 2-12 on page 2–17 for an illustration of the ACCB-L-L1.

See Figure 2-13 on page 2–18 for an illustration of the ACCB-L2-PCK installed in the ACCB-L-L1 to create the ACCB-L-L2.



WARNING: Shock Hazard

Any changes to factory wiring must meet local and national electrical codes.



WARNING: Fire Hazard

A possible fire hazard can exist if 120 Vac only sources (such as inverters and generators) are wired incorrectly into 120/240 Vac distribution panels containing multi wire branch circuits. For more information on multi-branch wiring, see the Xantrex website (www.xantrex.com).



WARNING: Shock Hazard

Be sure to connect the ground wires first when connecting AC wiring to prevent a potential shock hazard.



WARNING: Shock Hazard

While installing the components, ensure that no DC or AC voltage is being supplied to the inverter.

Accessing the AC Input/Output Terminal Block in the ACCB-L-L1

Consult the Sine Wave Plus Inverter/Charger Owner's Manual for additional information on wire and disconnect requirements.

To prepare the ACCB-L-L1 and inverter for wiring installation:

1. Expose the AC Input/Output Terminal Block in the ACCB-L-L1 by removing the front cover, as described on page 2–6.
2. Expose the terminal block in the SW Plus Inverter by removing the AC access cover, as described in your inverter's owner's guide.

Wire Sizes and Disconnect Requirements

The AC Input/Output Terminal block in the ACCB-L-L1 accept wires sized #2/0 to 14 AWG.

The ground bar in both models has nine holes and accepts #4 to 14 AWG wires.

The AC Bus Bar (for neutral and hot connections) has dual sizes. The smaller nine holes accept #6 to 14 AWG wire and the larger two holes accept #1/0 to 14 AWG.

Determine the wire sizes and disconnect sizes required for the installation. See Table 2-1 for torque values.

The full AC pass-thru capacity is 60 amps. For full pass-thru capability of this unit, a maximum fuse/breaker of 60 amps is recommended, which corresponds to a cable size of #6 AWG (THHN) in conduit. If you are using other wire sizes, please refer to your local electrical code for fuse/breaker requirements.

Important: Only use copper conductors rated for 75 °C (167 °F). All wiring within the Long AC Conduit Box enclosure, except low voltage control wiring, shall be rated at least 300 V or a combination of 300 V (e.g., 150 V cable enclosed with 150 V insulation/heat shrink). Control wiring can be rated for 150 V.

Table 2-1 Torque Values for Wiring

Wire Gauge	Torque Value
#14 to 10 AWG	35 in-lb
#8 AWG	40 in-lb
#6 to 2/0 AWG	120 in-lb



CAUTION: Equipment Damage

The inverter's AC output must never be wired to the utility or generator output. This will cause severe damage to the inverter which is not covered under warranty.

Important: These instructions assume that the DC connections have already been made and that the system ground has already been established. Consult the Sine Wave Plus Owner's Manual for additional wiring information.

Important: Be sure to use wire-ties as needed to keep field and factory-installed wiring neat and tidy so it does not interfere with airflow through the Long AC Conduit Box into the Sine Wave Plus Inverter/Charger. This also helps keep wiring away from potentially hot surfaces.

The following illustration provides the part numbers and placement location for all field-installable parts. Parts shown in this illustration have been approved by CSA. Some are available at Xantrex. Others are available at your local electrical supply distributor. Similar parts purchased from other vendors may be subject to approval from your local electrical authority.

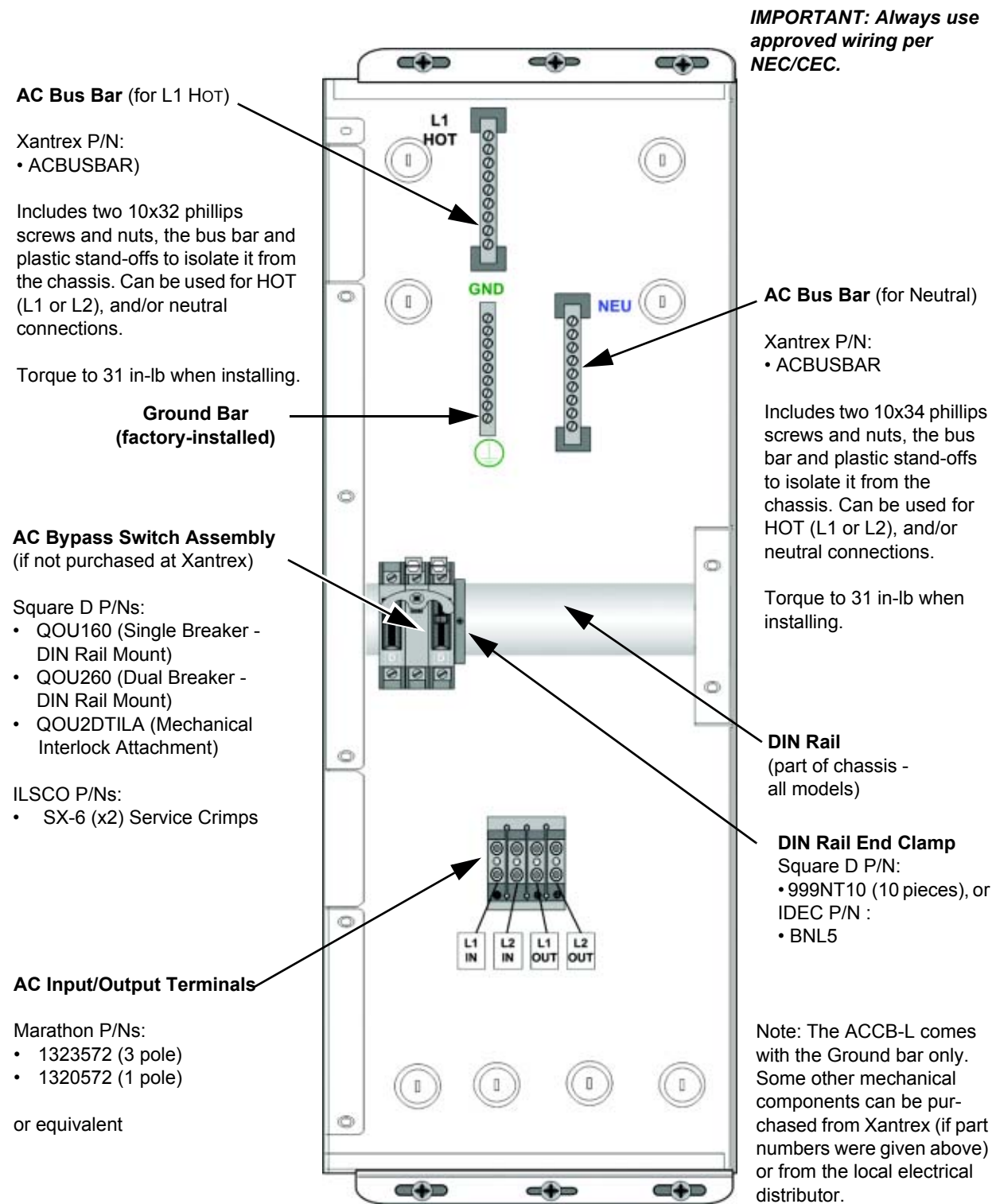

Figure 2-11 ACCB-L Approved Internal Components

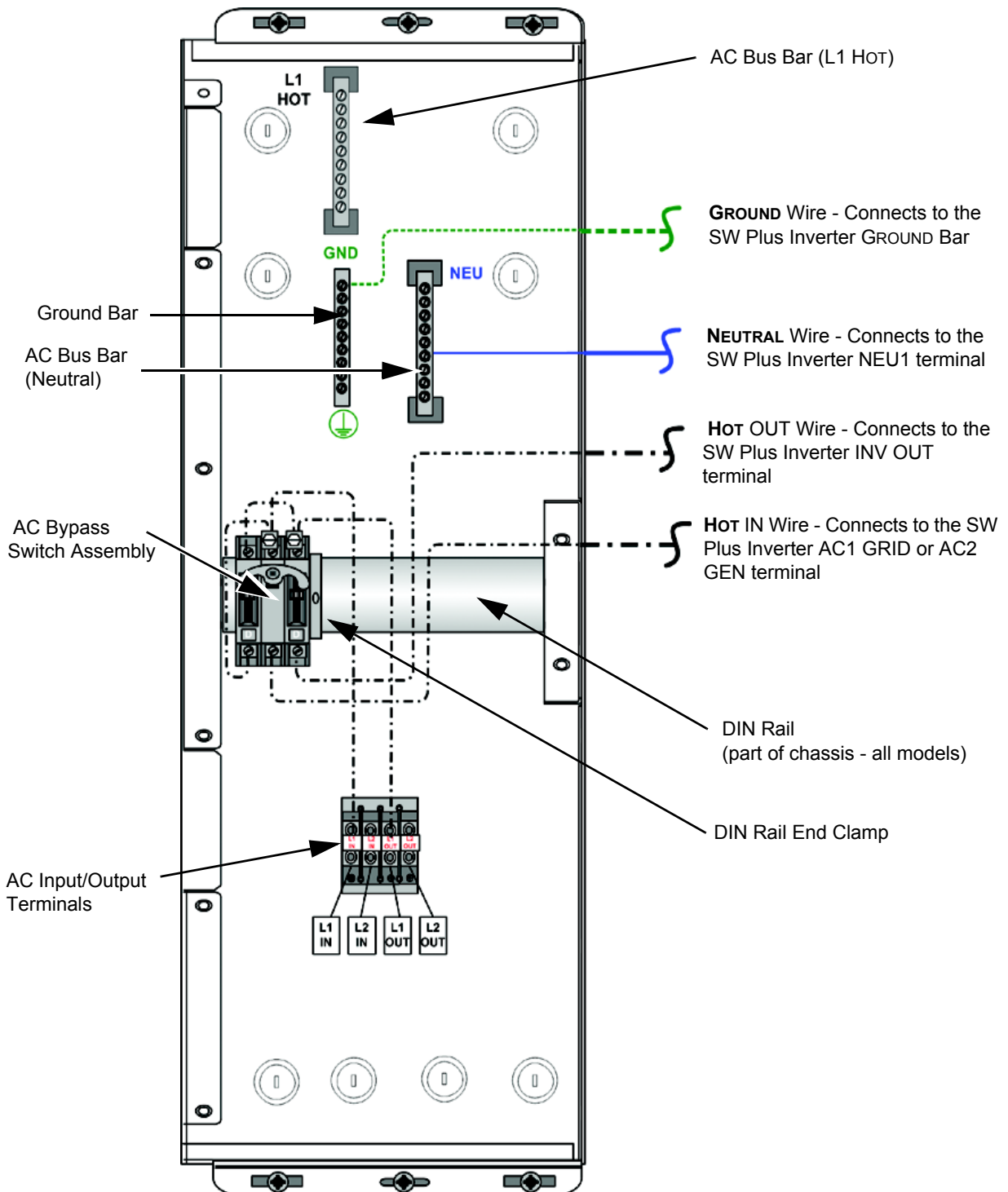

Figure 2-12 ACCB-L-L1 Internal Components (Factory installed)

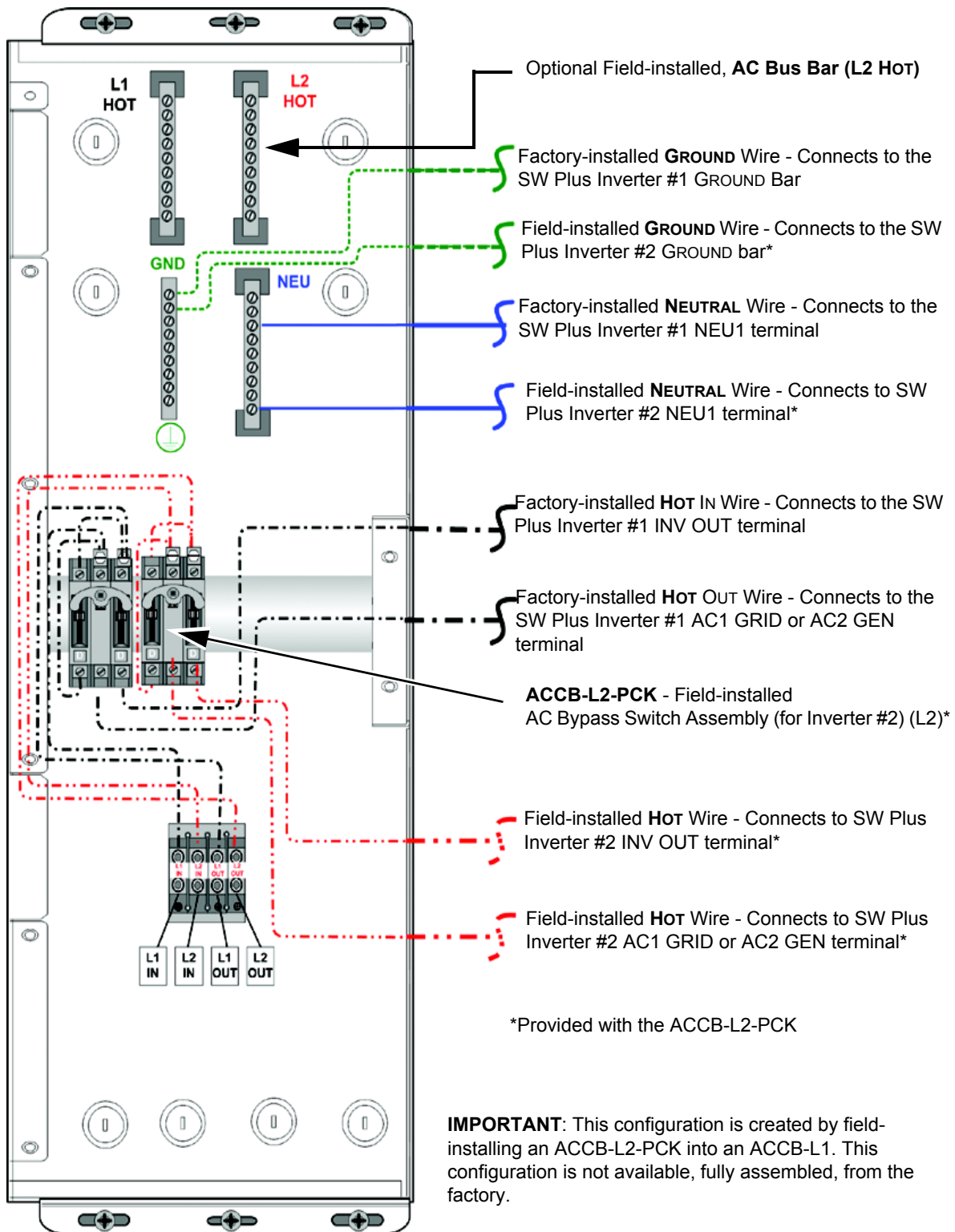

Figure 2-13 ACCB-L1 Internal Components with the Optional ACCB-L2-PKG Installed

Wiring for Off-Grid Applications

The following illustrations show the wiring examples for six basic off-grid configurations using the ACCB-L-L1 with a minimum number of breakers installed for clarity. For other possible configurations, consult a qualified electrician or a Xantrex certified dealer. (See www.xantrexREdealer.com).

Single Inverter Configurations (120 Vac)

The following illustration shows the complete wiring for the ACCB-L-L1 and SW Plus Inverter in an off-grid configuration. This illustration includes the use of a separate AC Distribution Panel.

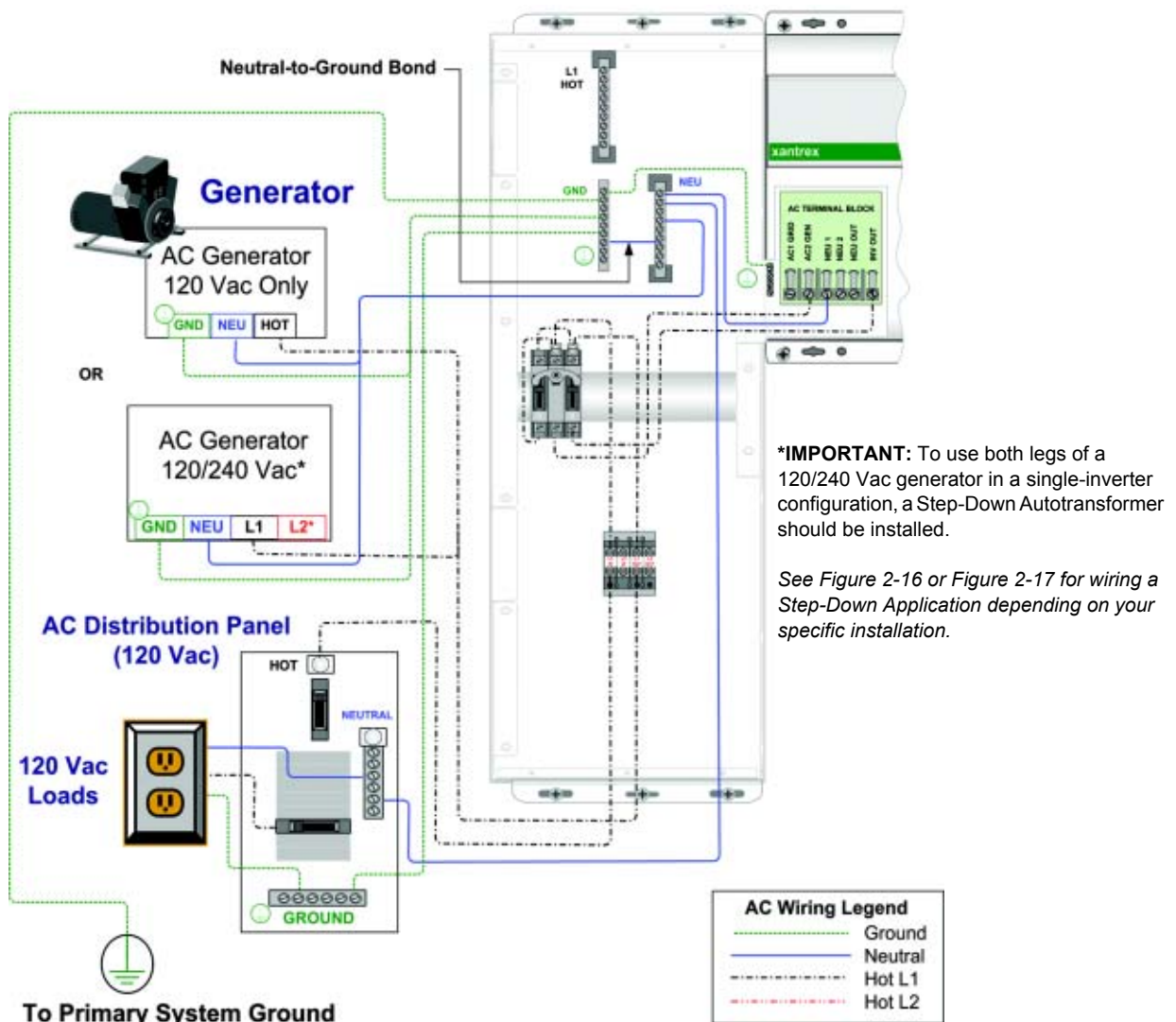

Figure 2-14 Wiring an Off-grid Application Using a Single Inverter

The following illustration shows the complete wiring for the ACCB-L-L1 and SW Plus Inverter in an off-grid configuration. This illustration includes the use of field-installed circuit breakers in the ACCB-L-L1 for AC distribution, instead of using a separate sub panel.

***IMPORTANT:** To use both legs of a 120/240 Vac generator in a single-inverter configuration, a Step-Down Autotransformer should be installed.

See Figure 2-16 or Figure 2-17 for wiring a Step-Down Application depending on your specific installation.

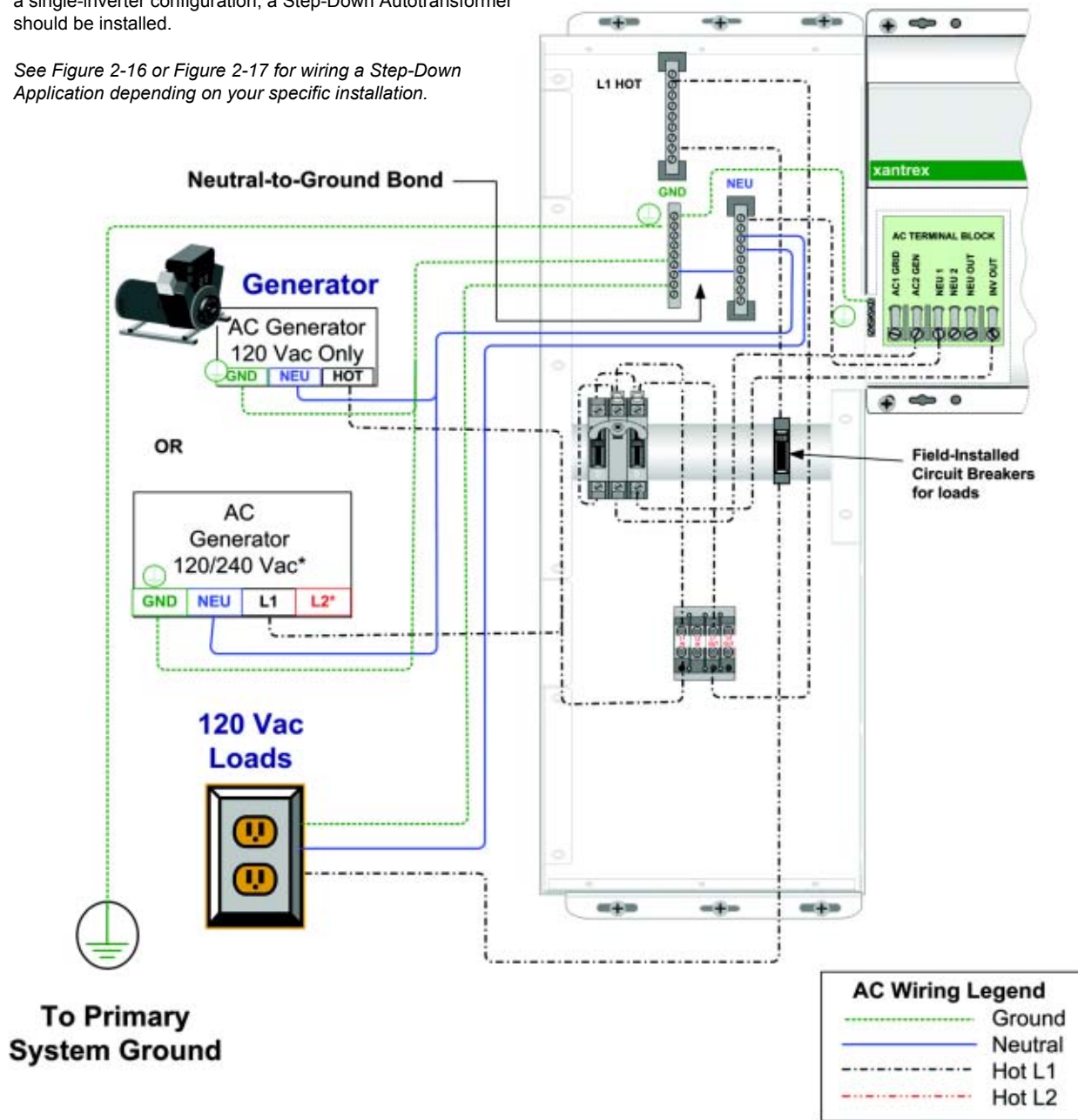

Figure 2-15 Wiring an Off-grid Application Using a Single Inverter (No Sub Panel)

Step-down Configurations (240 Vac to 120 Vac)

The following illustration shows the complete wiring for the ACCB-L-L1, TX Autotransformer, and a SW Plus Inverter for a Step-down Configuration to use a 240 Vac-Only Generator.

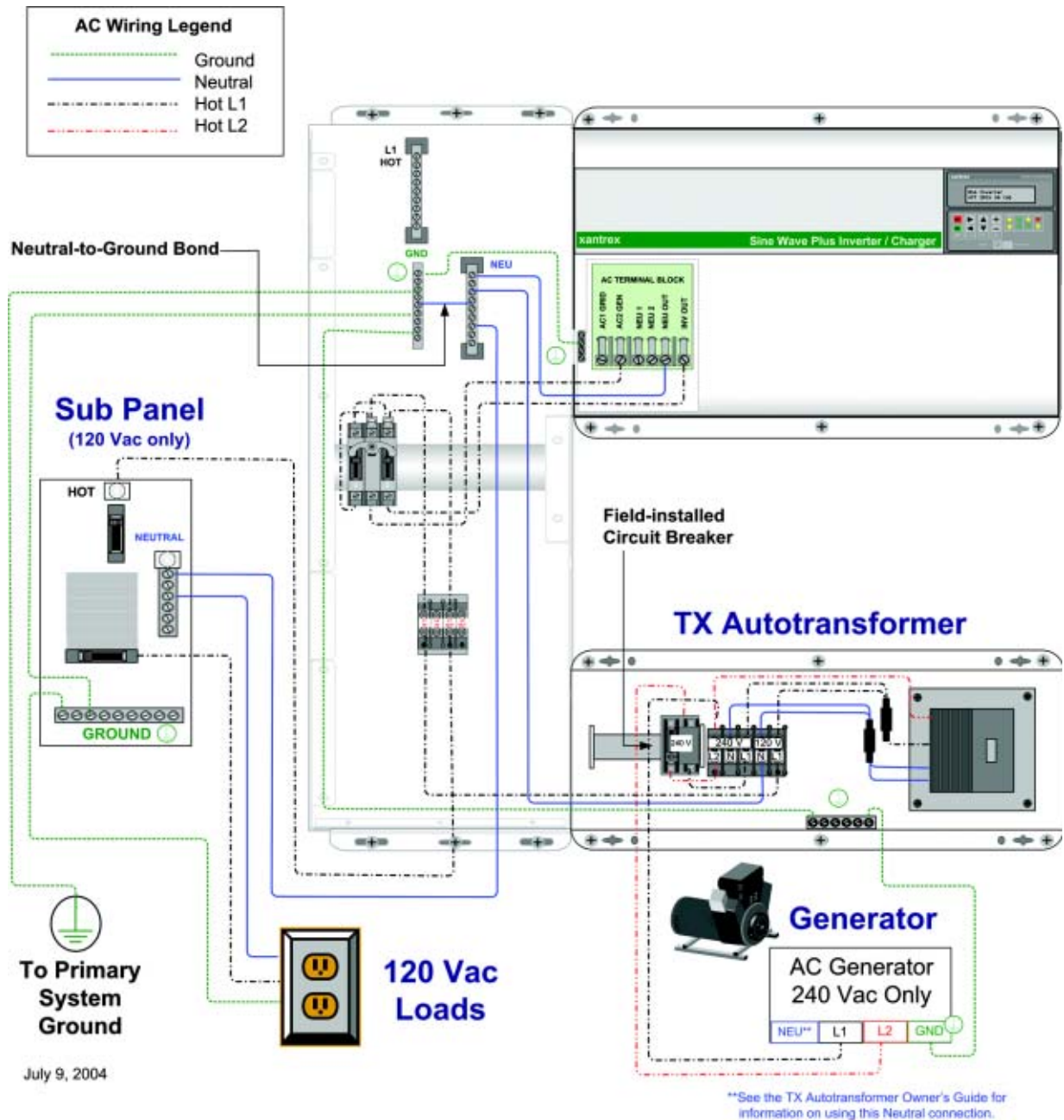
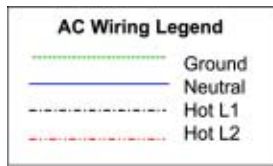

Figure 2-16 Wiring an Off-grid Application Using a Single Inverter and TX Autotransformer in a Step-Down Configuration

The following illustration shows the complete wiring for the ACCB-L-L1, TX Autotransformer, and a SW Plus Inverter for a Step-down Configuration to use a 240 Vac-Only Generator. This configuration uses the ACCB-L-L1 as the sub panel.



Note: Because there is only one circuit breaker installed (other than the AC Bypass Switch), the output for the ACCB-L doesn't need to be connected to the L1 HOT Bus Bar. It can be connected to the line side of the field-installed circuit breaker.

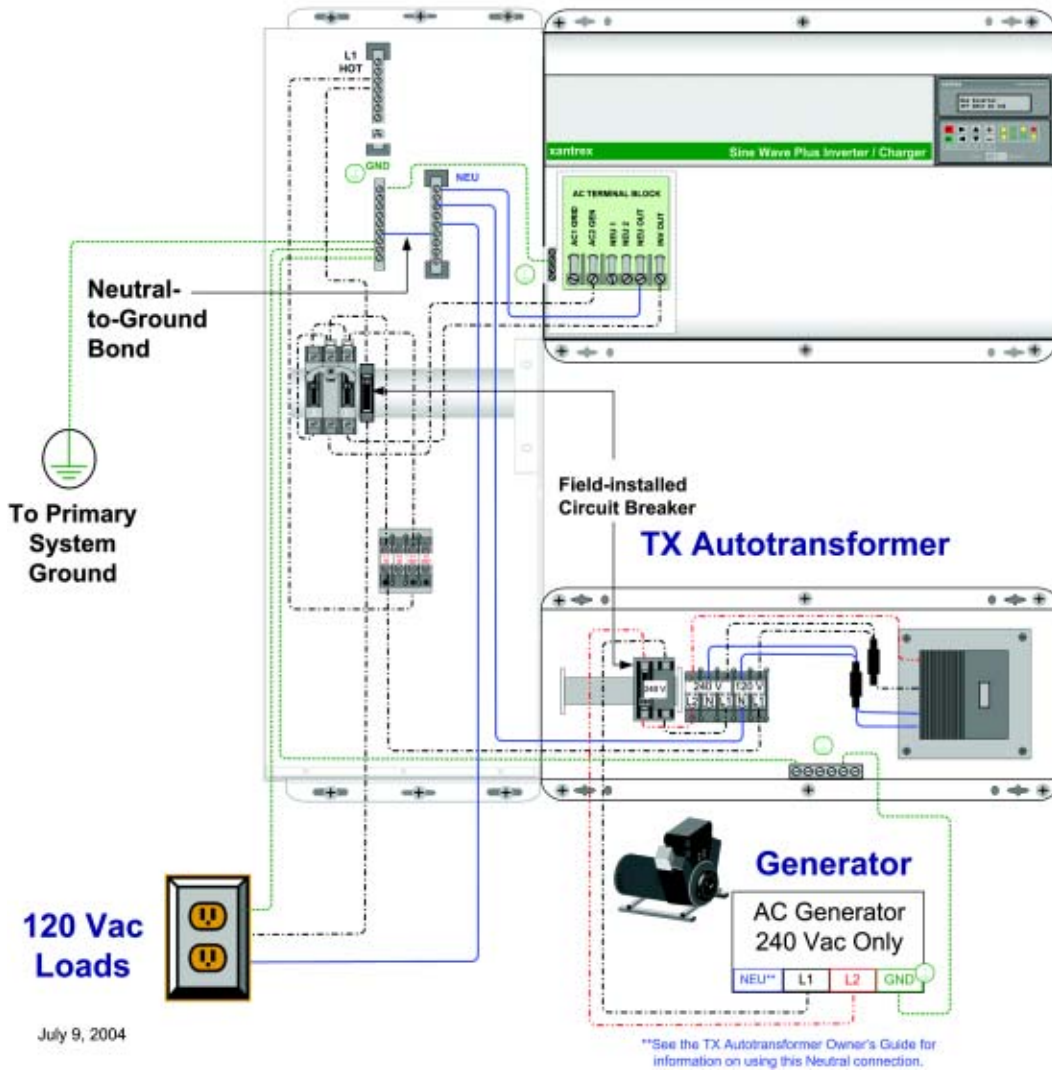

Figure 2-17 Wiring an Off-grid Application Using a Single Inverter and TX Autotransformer for a Step-Down Configuration (No Sub Panel)

Step-up Configuration (Deep Well Pump) (120 Vac to 240 Vac)

The following illustration shows the complete wiring for the ACCB-L-L1, TX Autotransformer, and a SW Plus Inverter for a Step-up Configuration to provide power for a 240 Vac Load.

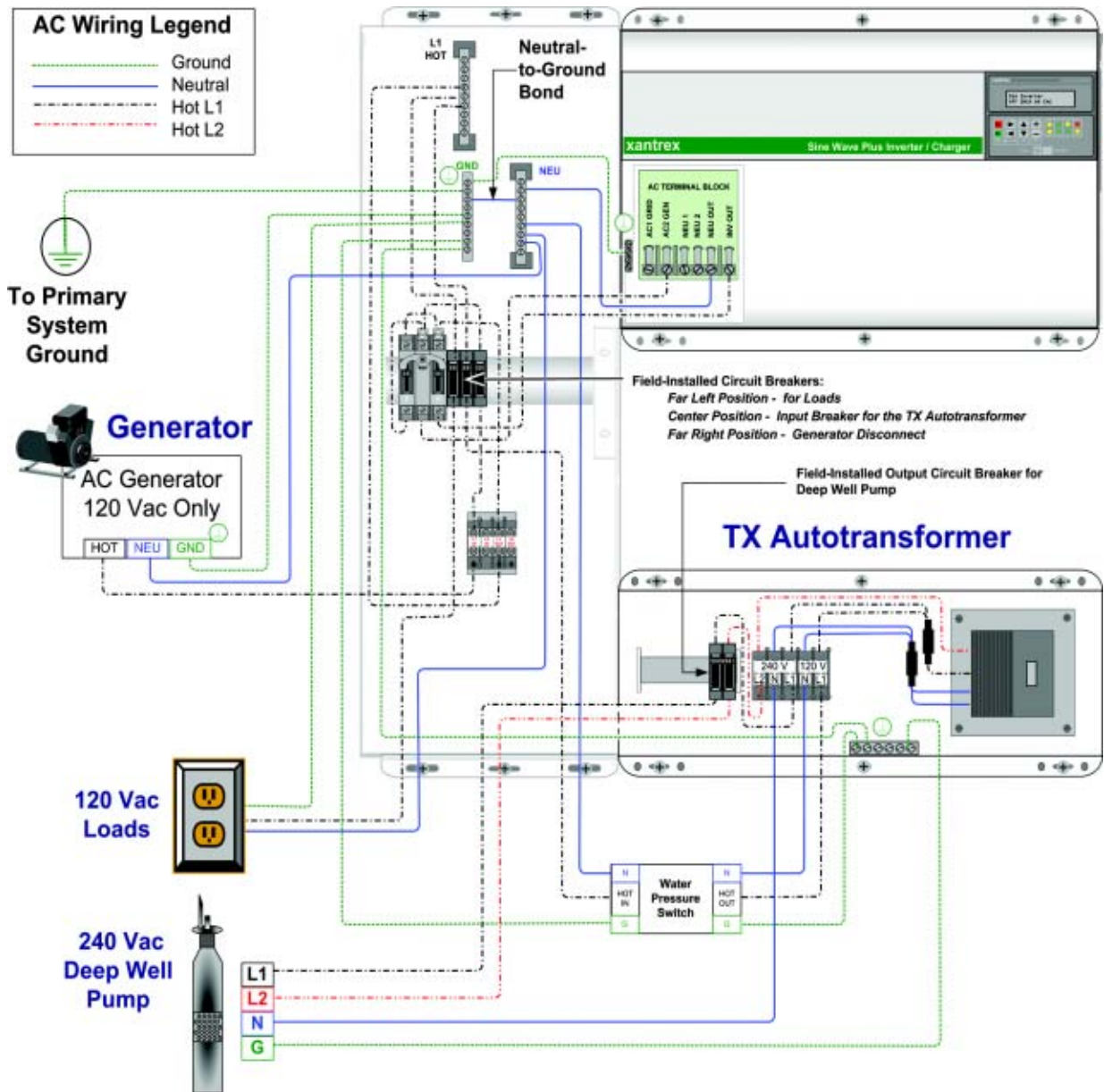

Figure 2-18 Wiring an Off-grid Application Using a Single Inverter and TX Autotransformer for a Step-Up Configuration for a Deep Well Pump Application

Dual Inverter Configurations (120 Vac and 240 Vac)

The following illustration shows the complete wiring for the ACCB-L-L2 (ACCB-L-L1 with ACCB-L2-PCK installed) and dual SW Plus Inverters in an off-grid application. In this configuration, the generator's output (L1 and L2) is connected to the AC Bypass breakers, then to the SW Plus input and output.

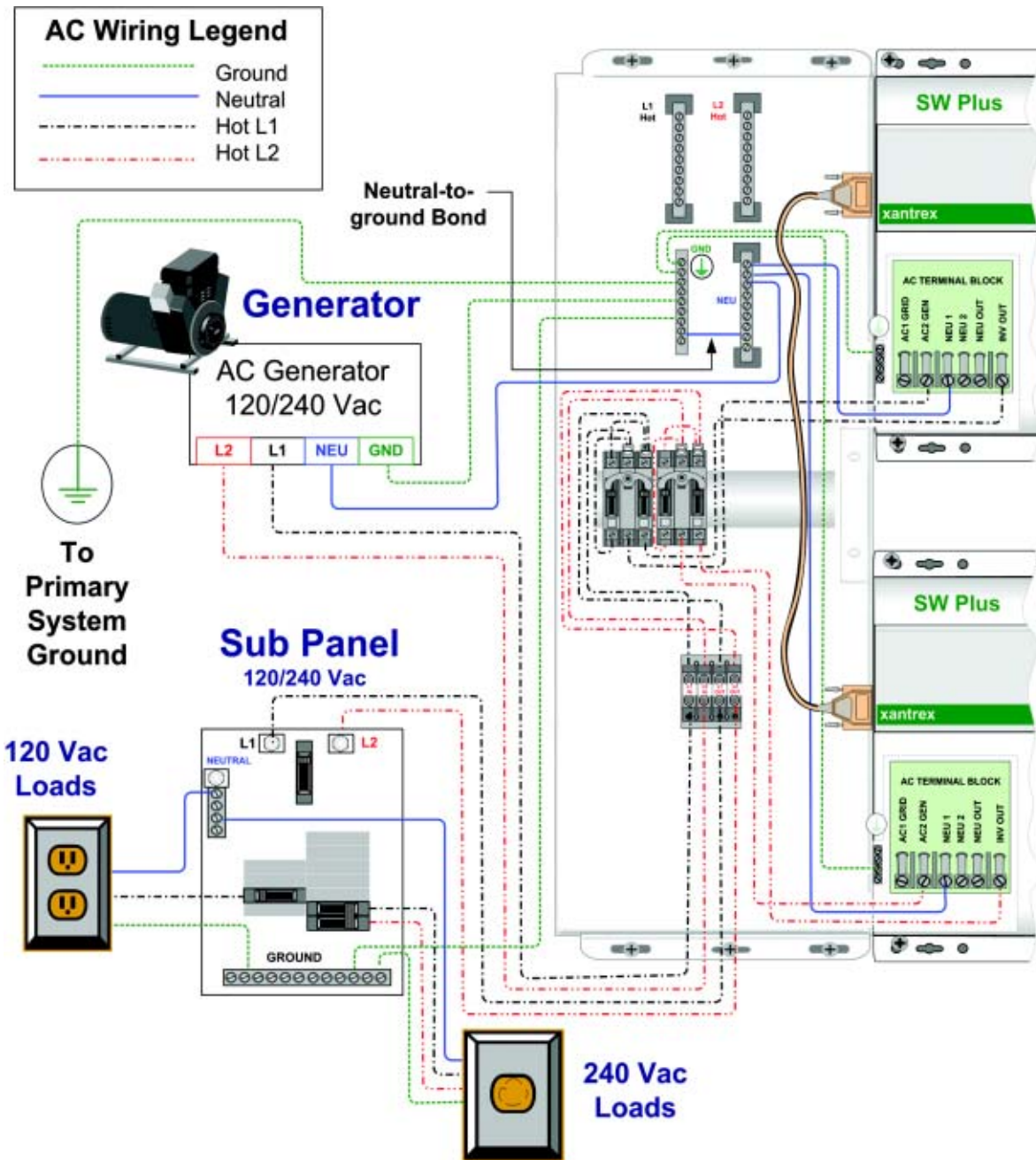

Figure 2-19 Wiring an Off-grid Application Using Dual Inverters (ACCB-L-L2)

Wiring for On-Grid Applications

The following illustrations show the complete wiring to the six basic on-grid configurations. For other possible configurations, consult a qualified electrician or a Xantrex certified dealer (See www.xantrexREdealer.com).

Single Inverter Configurations (120 Vac)

The following illustration shows the complete wiring for the ACCB-L-L1 and SW Plus Inverter in an on-grid configuration. This diagram also includes the use of a generator disconnect breaker in the ACCB-L-L1.

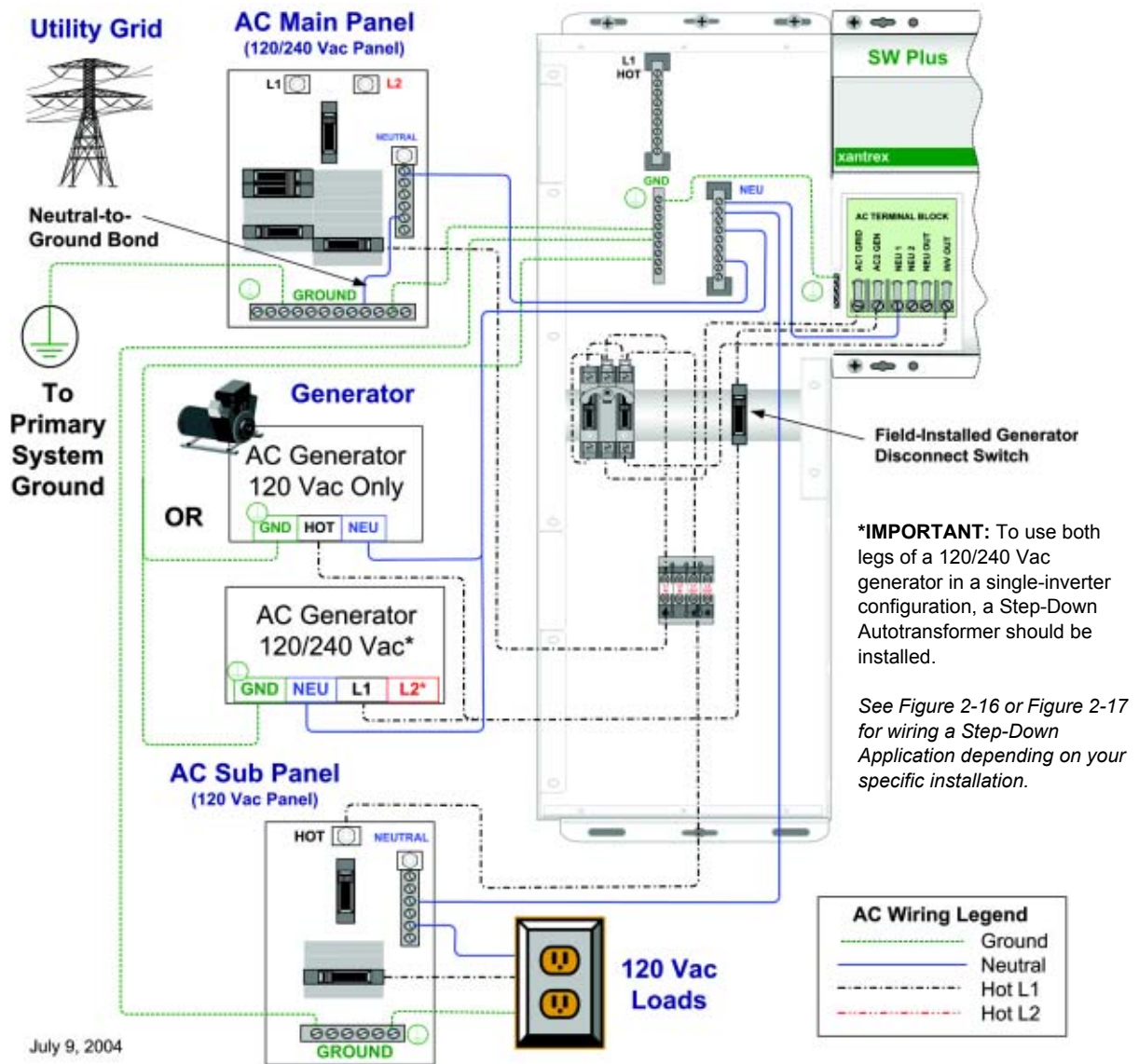

Figure 2-20 Wiring an On-grid Application Using a Single Inverter

The following illustration shows the complete wiring for the ACCB-L-L1 and SW Plus Inverter in an on-grid configuration. This diagram includes the use of a generator disconnect breaker and load breakers in the ACCB-L-L1.

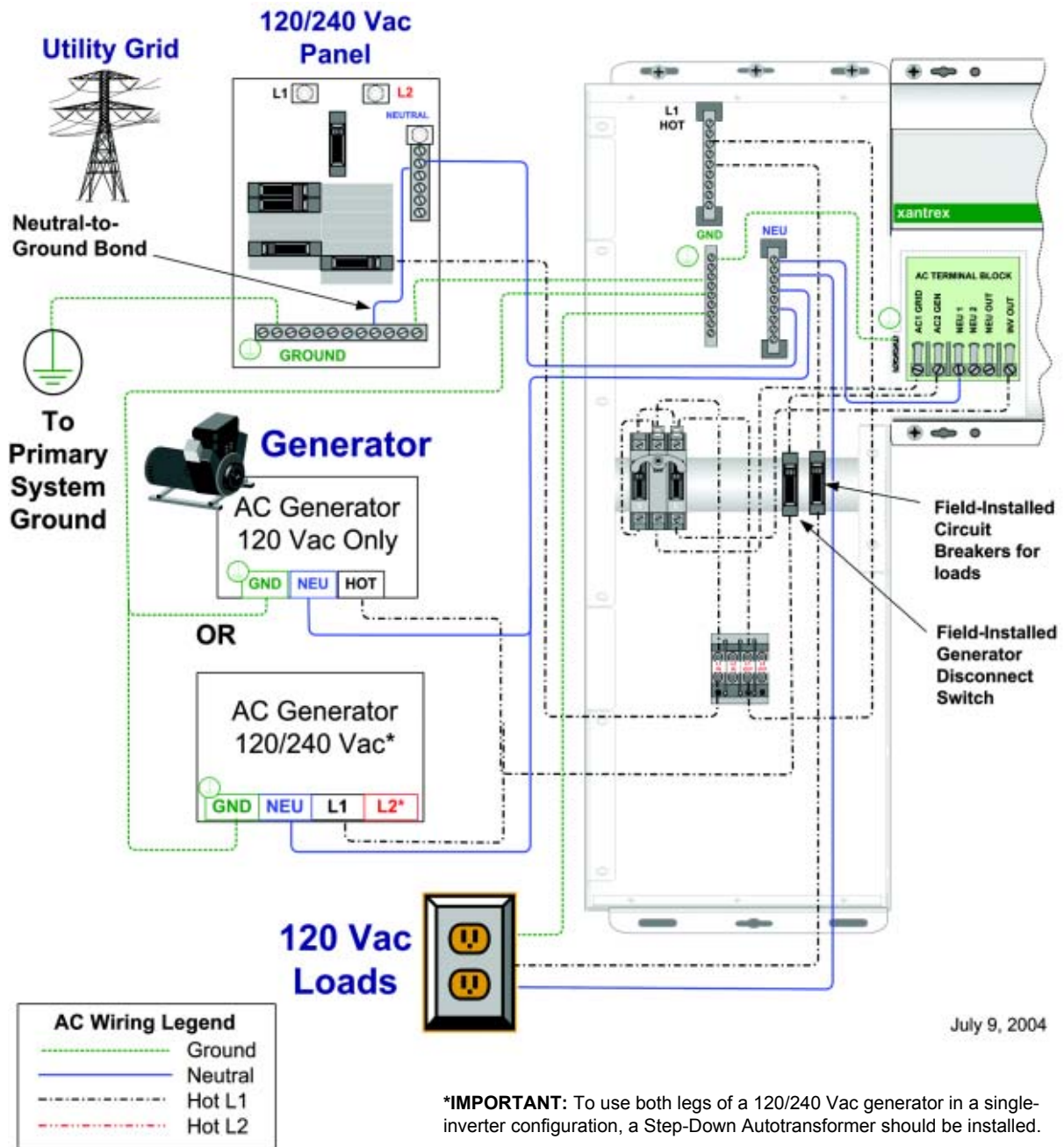

Figure 2-21 Wiring an On-grid Application Using a Single Inverter (No Sub Panel)

Step-up Configurations (Utility Backup) (120 Vac to 240 Vac)

The following illustration shows the complete wiring for the ACCB-L-L1, TX Autotransformer, and a SW Plus Inverter for a Step-up Configuration to provide power for a 240 Vac Load.

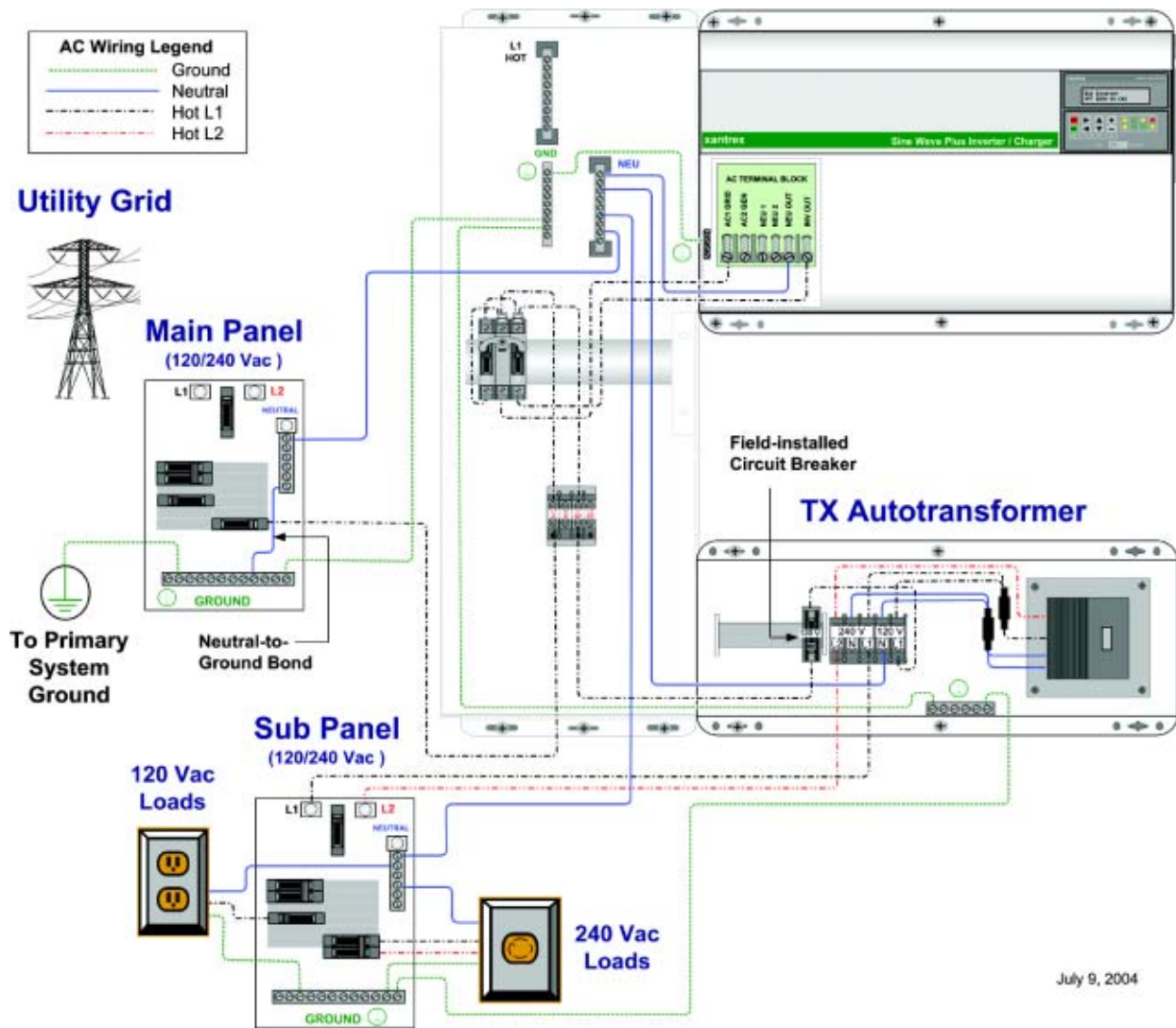

Figure 2-22 Wiring an On-grid Application Using a Single Inverter and TX Autotransformer for a Step-Up Configuration for Utility Backup

Dual Inverter Configurations (120 Vac and 240 Vac)

The following illustration shows the complete wiring for the ACCB-L-L2 (ACCB-L-L1 with ACCB-L2-PCK installed) and dual SW Plus Inverters in an on-grid application. In this configuration, the utility grid is connected to the AC Bypass Breakers, then to the SW Plus input and output.

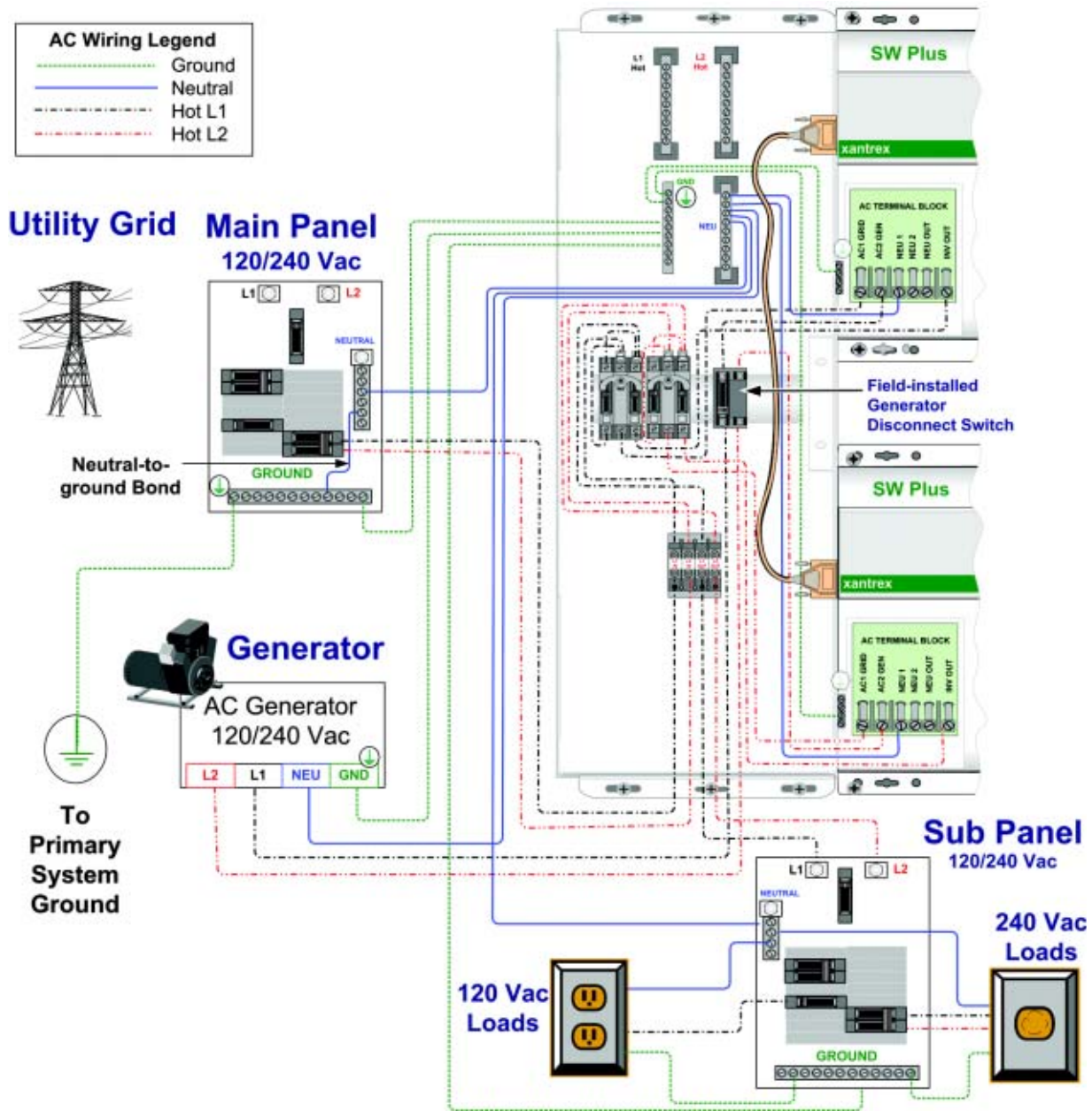

Figure 2-23 Wiring an On-grid Application Using Dual Inverters (ACCB-L-L2)

Additional Accessory Wiring

If you have any of the following accessories connected (or to be connected) to your inverter, then you will also need to pass their connecting cables through the Long AC Conduit Box to the AC side of the inverter:

- **Generator Start Module (GSM)** for automatic generator control
- **Auxiliary Load Module (ALM)** for controlling auxiliary loads such as alarms or ventilator fans
- **Emergency Power Off (EPO) switch** (not supplied by Xantrex)
- **Inverter Control Module (ICM)**, or an **Inverter Communications Adapter (ICA)** for remote control and monitoring of the inverter
- **Inverter Stacking Control – Series (ISC-S) Cable** for connecting to another inverter in a dual-inverter, series-stacked configuration.

See your inverter owner's guide and the appropriate accessory guide for further information about the installation and configuration of these accessories.

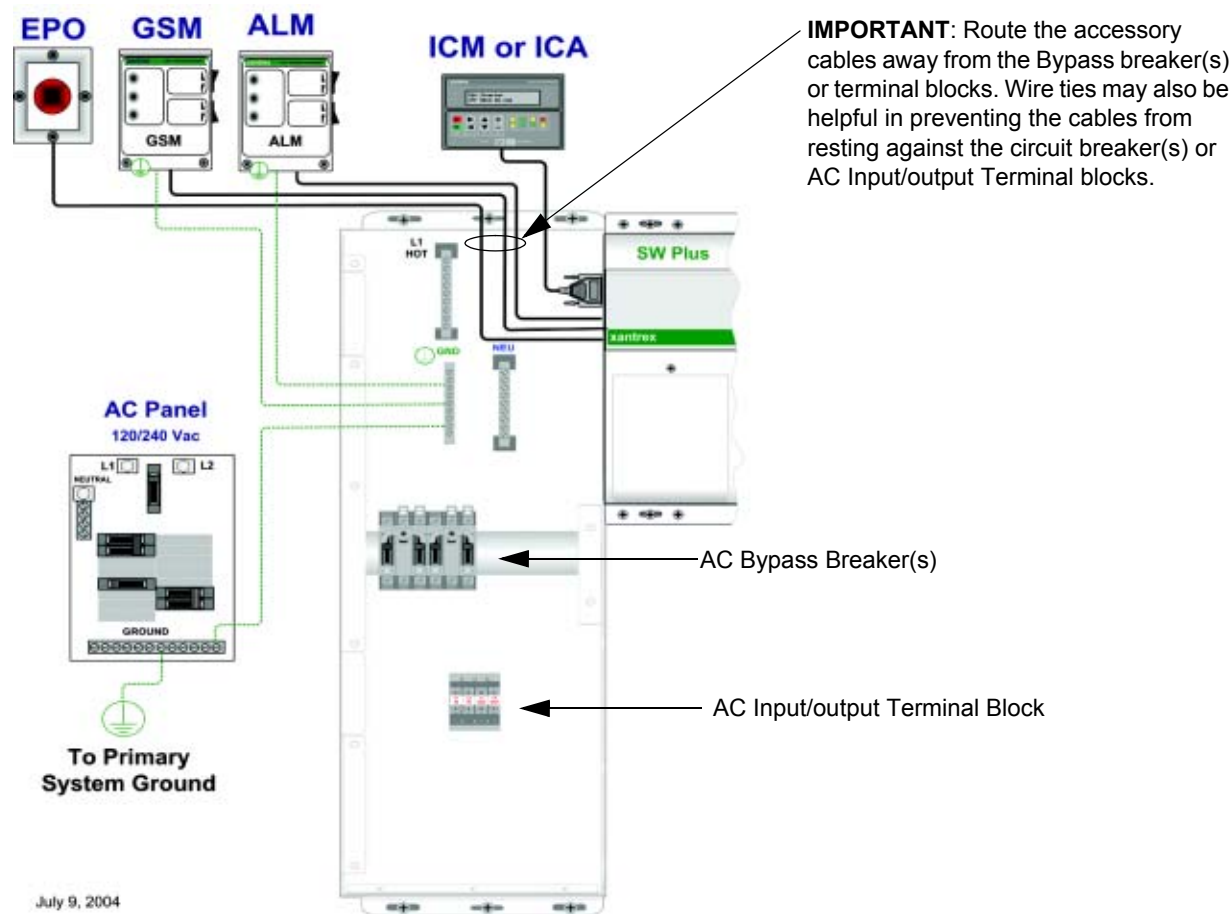

Figure 2-24 Accessory Wiring for Single-Inverter Configurations

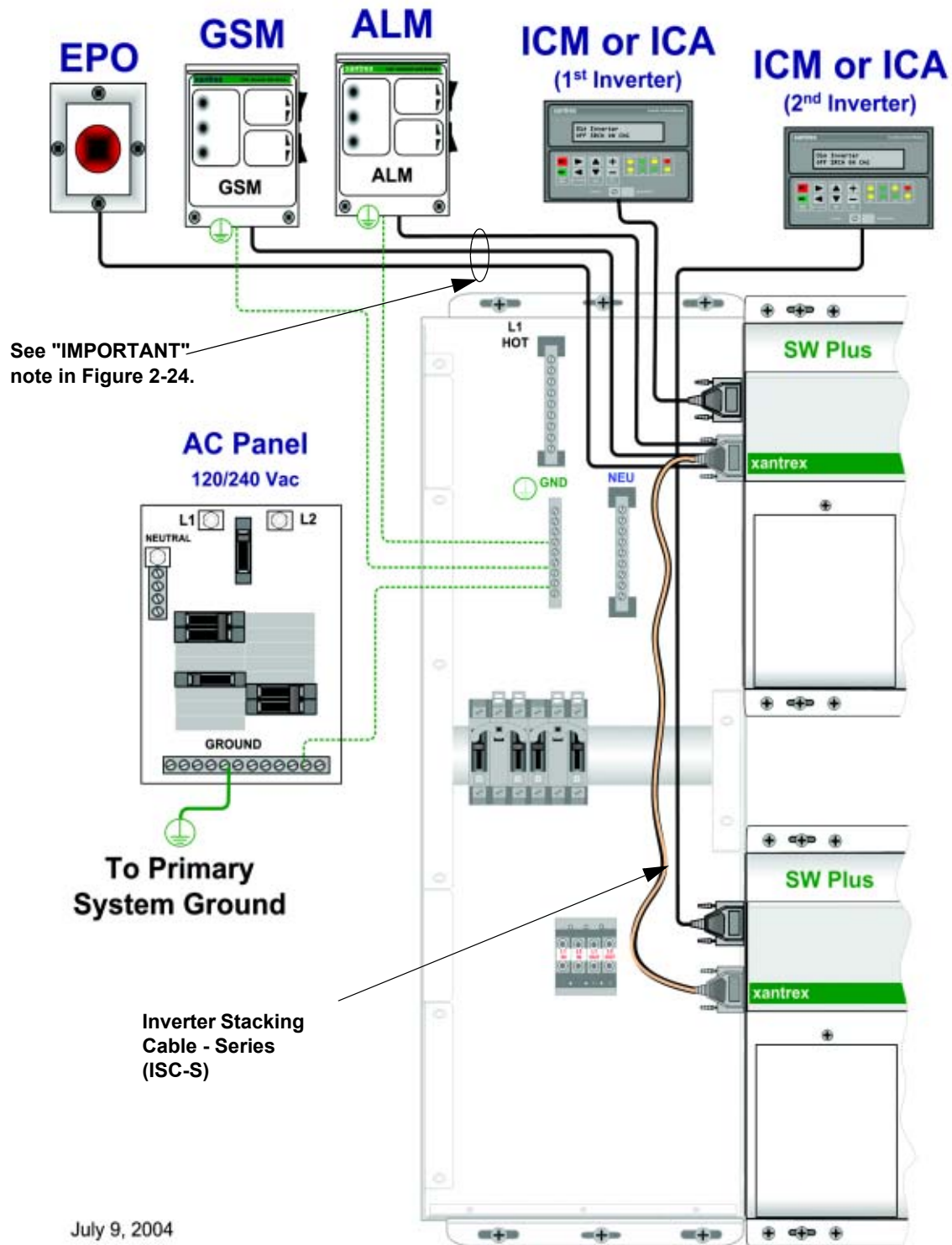

Figure 2-25 Accessory Wiring for Dual-Inverter Configurations

3

Operation

Chapter 3, “Operation” describes the different modes and operation of the AC Bypass Switch(es) on the ACCB-L-L1, or for the second AC Bypass Switch (ACCB-L-L2) if installed.

The following topics are covered in this chapter.

For this topic:	See:
“The AC Bypass Switch”	page 3–2
“Operating the AC Bypass Switch”	page 3–2
“Dual Inverters: 240 Vac Loads”	page 3–4

The AC Bypass Switch

During normal operation (Figure 3-2 on page 3–3), AC power passes from the single external AC source (generator or grid) through the inverter to the AC loads. The inverter monitors the incoming power and uses this power to keep the batteries charged.

When this external source of AC power is not available, the inverter switches to external DC power (e.g., batteries, generator, solar, wind, hydro) and continues to power the load.

When performing inverter maintenance, the breakers can be switched to the Bypass Operation (Figure 3-3 on page 3–3) which allows the AC loads to be powered directly from the external AC source without affecting connected AC loads.

To de-energize both circuits, switch the breaker pair to the OFF position (Figure 3-4 on page 3–4).

Operating the AC Bypass Switch

Once the AC voltage has been applied, the bypass switch is ready for operation. Under normal operation the Inverter Output breaker is ON.

There are three possible modes of operation for the bypass switch:

- “Normal Operation”
- “Bypass Operation”
- “AC Input/Output Off”

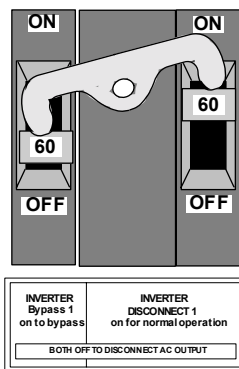

NORMAL OPERATION:
Left Breaker = OFF
Right Breaker = ON

Inverter AC power
available to Inverter
AC Distribution Panel

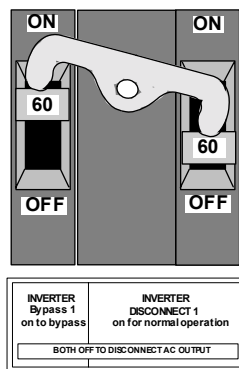

BYPASS OPERATION:
Left Breaker = ON
Right Breaker = OFF

Utility or Generator AC
power available to Inverter
AC Distribution Panel

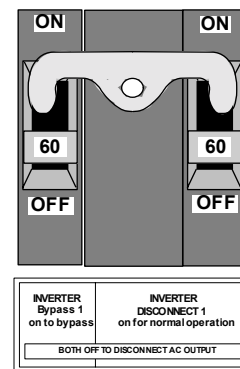

AC OFF OPERATION:
Left Breaker = OFF
Right Breaker = OFF

Utility/Generator/Inverter AC
power disconnected to Inverter
AC Distribution Panel

Figure 3-1 AC Bypass Switch Mode Summary

Normal Operation

External AC power passes to the AC Bypass Switch through the inverter to power the load (Figure 3-2).

In this configuration, power passes from the inverter, through the AC Bypass Switch, to the connected load. When external AC power is not available, power from the external DC source is used by the inverter to power the AC loads.

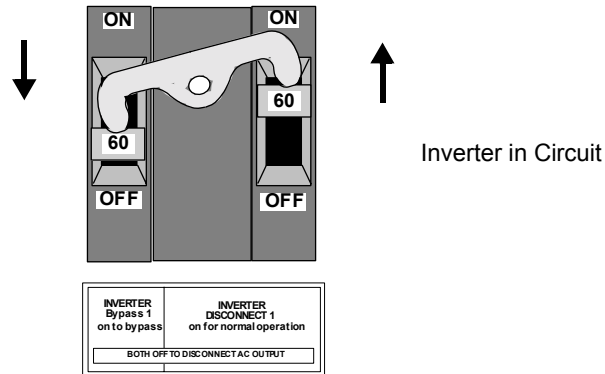

Figure 3-2 Normal Operation

Bypass Operation

External AC power routed through the AC Bypass Switch directly to the AC loads (Figure 3-3).

In this configuration, power passes directly to the connected load, bypassing the inverter (via the AC Bypass Switch). This allows the inverter to be removed from service without affecting the connected load. If the external source of AC becomes unavailable while the Bypass Operation is selected, the load will be dropped.

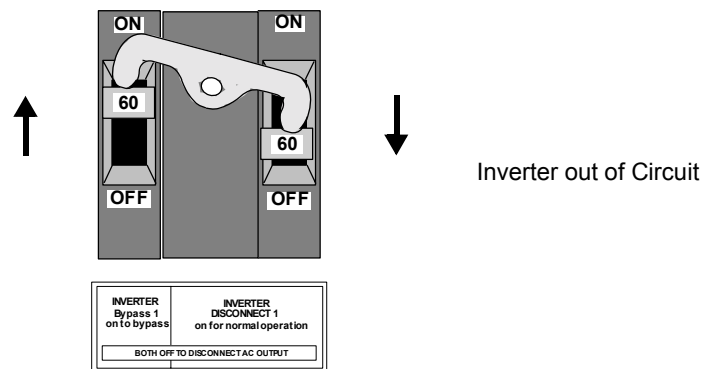

Figure 3-3 Bypass Operation

AC Input/Output Off

No power to the load or inverter (Figure 3-4).

In this configuration, power from both the external sources of AC and the inverter is removed from the loads. This allows the inverter that is connected to the AC Bypass breaker to be removed for service.

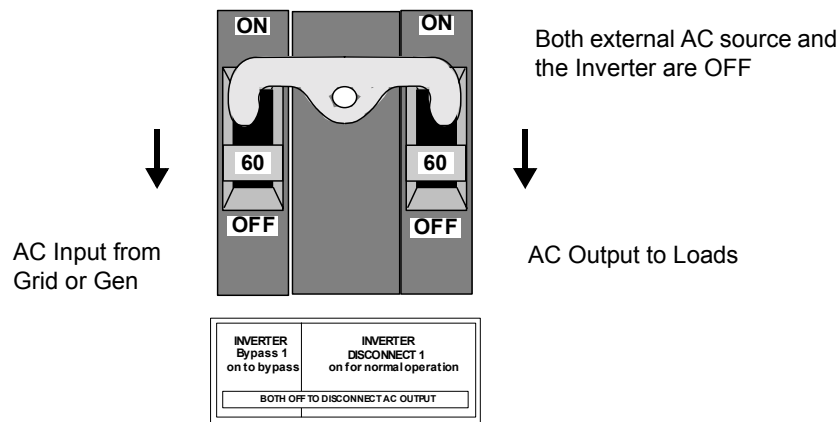

Figure 3-4 AC Output OFF

Dual Inverters: 240 Vac Loads



WARNING: Fire Hazard

In a series-stacked, inverter installation (120/240 Vac) with an AC Bypass switch for each inverter, both AC Bypass switches must be in the same position.

If the AC Bypass switches are not in the same position, the resulting AC output of the two AC Bypass switches may not be 180° out-of-phase from each other. This can result in excess current on the neutral wire creating a potential fire hazard.

This can also result in less than 240 Vac output. Loads requiring 240 Vac will not run. Some 240 Vac equipment may also be damaged if one AC “leg” is lost.

Warranty and Return Information

Warranty

What does this warranty cover? This Limited Warranty is provided by Xantrex Technology, Inc. ("Xantrex") and covers defects in workmanship and materials in your Sine Wave Plus Long AC Conduit Box. This warranty period lasts for two (2) years from the date of purchase at the point of sale to you, the original end user customer. You require proof of purchase to make warranty claims.

This Limited Warranty is transferable to subsequent owners but only for the unexpired portion of the Warranty Period. Subsequent owners also require proof of purchase.

What will Xantrex do? Xantrex will, at its option, repair or replace the defective product free of charge, provided that you notify Xantrex of the product defect within the Warranty Period, and provided that Xantrex through inspection establishes the existence of such a defect and that it is covered by this Limited Warranty.

Xantrex will, at its option, use new and/or reconditioned parts in performing warranty repair and building replacement products. Xantrex reserves the right to use parts or products of original or improved design in the repair or replacement. If Xantrex repairs or replaces a product, its warranty continues for the remaining portion of the original Warranty Period or 90 days from the date of the return shipment to the customer, whichever is greater. All replaced products and all parts removed from repaired products become the property of Xantrex.

Xantrex covers both parts and labor necessary to repair the product, and return shipment to the customer via a Xantrex-selected non-expedited surface freight within the contiguous United States and Canada. Alaska and Hawaii are excluded. Contact Xantrex Customer Service for details on freight policy for return shipments outside of the contiguous United States and Canada.

How do you get service? If your product requires troubleshooting or warranty service, contact your merchant. If you are unable to contact your merchant, or the merchant is unable to provide service, contact Xantrex directly at:

Telephone: 1 800 670 0707 (toll free North America)
1 360 925 5097 (direct)

Fax: 1 800 994 7828 (toll free North America)
1 360 925 5143 (direct)

Email: customerservice@xantrex.com

Direct returns may be performed according to the Xantrex Return Material Authorization Policy described in your product manual. For some products, Xantrex maintains a network of regional Authorized Service Centers. Call Xantrex or check our website to see if your product can be repaired at one of these facilities.

What proof of purchase is required? In any warranty claim, dated proof of purchase must accompany the product and the product must not have been disassembled or modified without prior written authorization by Xantrex. Proof of purchase may be in any one of the following forms:

- The dated purchase receipt from the original purchase of the product at point of sale to the end user, or
- The dated dealer invoice or purchase receipt showing original equipment manufacturer (OEM) status, or
- The dated invoice or purchase receipt showing the product exchanged under warranty

Warranty and Return

What does this warranty not cover? This Limited Warranty does not cover normal wear and tear of the product or costs related to the removal, installation, or troubleshooting of the customer's electrical systems. This warranty does not apply to and Xantrex will not be responsible for any defect in or damage to:

- a) the product if it has been misused, neglected, improperly installed, physically damaged or altered, either internally or externally, or damaged from improper use or use in an unsuitable environment;
- b) the product if it has been subjected to fire, water, generalized corrosion, biological infestations, or input voltage that creates operating conditions beyond the maximum or minimum limits listed in the Xantrex product specifications including high input voltage from generators and lightning strikes;
- c) the product if repairs have been done to it other than by Xantrex or its authorized service centers (hereafter "ASCs");
- d) the product if it is used as a component part of a product expressly warranted by another manufacturer;
- e) the product if its original identification (trade-mark, serial number) markings have been defaced, altered, or removed.

Disclaimer

Product

THIS LIMITED WARRANTY IS THE SOLE AND EXCLUSIVE WARRANTY PROVIDED BY XANTREX IN CONNECTION WITH YOUR XANTREX PRODUCT AND IS, WHERE PERMITTED BY LAW, IN LIEU OF ALL OTHER WARRANTIES, CONDITIONS, GUARANTEES, REPRESENTATIONS, OBLIGATIONS AND LIABILITIES, EXPRESS OR IMPLIED, STATUTORY OR OTHERWISE IN CONNECTION WITH THE PRODUCT, HOWEVER ARISING (WHETHER BY CONTRACT, TORT, NEGLIGENCE, PRINCIPLES OF MANUFACTURER'S LIABILITY, OPERATION OF LAW, CONDUCT, STATEMENT OR OTHERWISE), INCLUDING WITHOUT RESTRICTION ANY IMPLIED WARRANTY OR CONDITION OF QUALITY, MERCHANTABILITY OR FITNESS FOR A PARTICULAR PURPOSE. ANY IMPLIED WARRANTY OF MERCHANTABILITY OR FITNESS FOR A PARTICULAR PURPOSE TO THE EXTENT REQUIRED UNDER APPLICABLE LAW TO APPLY TO THE PRODUCT SHALL BE LIMITED IN DURATION TO THE PERIOD STIPULATED UNDER THIS LIMITED WARRANTY.

IN NO EVENT WILL XANTREX BE LIABLE FOR ANY SPECIAL, DIRECT, INDIRECT, INCIDENTAL OR CONSEQUENTIAL DAMAGES, LOSSES, COSTS OR EXPENSES HOWEVER ARISING WHETHER IN CONTRACT OR TORT INCLUDING WITHOUT RESTRICTION ANY ECONOMIC LOSSES OF ANY KIND, ANY LOSS OR DAMAGE TO PROPERTY, ANY PERSONAL INJURY, ANY DAMAGE OR INJURY ARISING FROM OR AS A RESULT OF MISUSE OR ABUSE, OR THE INCORRECT INSTALLATION, INTEGRATION OR OPERATION OF THE PRODUCT.

Exclusions

If this product is a consumer product, federal law does not allow an exclusion of implied warranties. To the extent you are entitled to implied warranties under federal law, to the extent permitted by applicable law they are limited to the duration of this Limited Warranty. Some states and provinces do not allow limitations or exclusions on implied warranties or on the duration of an implied warranty or on the limitation or exclusion of incidental or consequential damages, so the above limitation(s) or exclusion(s) may not apply to you. This Limited Warranty gives you specific legal rights. You may have other rights which may vary from state to state or province to province.

Warning: Limitations On Use

Please refer to your product manual for limitations on uses of the product.

SPECIFICALLY, PLEASE NOTE THAT THE SINE WAVE PLUS LONG AC CONDUIT BOX SHOULD NOT BE USED IN CONNECTION WITH LIFE SUPPORT SYSTEMS OR OTHER MEDICAL EQUIPMENT OR DEVICES. WITHOUT LIMITING THE GENERALITY OF THE FOREGOING, XANTREX MAKES NO REPRESENTATIONS OR WARRANTIES REGARDING THE USE OF THE XANTREX SINE WAVE PLUS LONG AC CONDUIT BOX IN CONNECTION WITH LIFE SUPPORT SYSTEMS OR OTHER MEDICAL EQUIPMENT OR DEVICES.

Please note that the Sine Wave Plus Long AC Conduit Box is not intended for use as an uninterruptedly power supply and Xantrex makes no warranty or representation in connection with any use of the product for such purposes.

Return Material Authorization Policy

Before returning a product directly to Xantrex you must obtain a Return Material Authorization (RMA) number and the correct factory "Ship To" address. Products must also be shipped prepaid. Product shipments will be refused and returned at your expense if they are unauthorized, returned without an RMA number clearly marked on the outside of the shipping box, if they are shipped collect, or if they are shipped to the wrong location.

When you contact Xantrex to obtain service, please have your instruction manual ready for reference and be prepared to supply:

- The serial number of your product
- Information about the installation and use of the unit
- Information about the failure and/or reason for the return
- A copy of your dated proof of purchase

Record these details in on page WA-4.

Return Procedure

1. Package the unit safely, preferably using the original box and packing materials. Please ensure that your product is shipped fully insured in the original packaging or equivalent. This warranty will not apply where the product is damaged due to improper packaging.
2. Include the following:
 - The RMA number supplied by Xantrex Technology, Inc. clearly marked on the outside of the box.
 - A return address where the unit can be shipped. Post office boxes are not acceptable.
 - A contact telephone number where you can be reached during work hours.
 - A brief description of the problem.
3. Ship the unit prepaid to the address provided by your Xantrex customer service representative.

If you are returning a product from outside of the USA or Canada In addition to the above, you MUST include return freight funds and are fully responsible for all documents, duties, tariffs, and deposits.

If you are returning a product to a Xantrex Authorized Service Center (ASC) A Xantrex return material authorization (RMA) number is not required. However, you must contact the ASC prior to returning the product or presenting the unit to verify any return procedures that may apply to that particular facility.

Out of Warranty Service

If the warranty period for your Sine Wave Plus Long AC Conduit Box has expired, if the unit was damaged by misuse or incorrect installation, if other conditions of the warranty have not been met, or if no dated proof of purchase is available, your inverter may be serviced or replaced for a flat fee.

To return your Sine Wave Plus Long AC Conduit Box for out of warranty service, contact Xantrex Customer Service for a Return Material Authorization (RMA) number and follow the other steps outlined in "Return Procedure" on page WA-3.

Payment options such as credit card or money order will be explained by the Customer Service Representative. In cases where the minimum flat fee does not apply, as with incomplete units or units with excessive damage, an additional fee will be charged. If applicable, you will be contacted by Customer Service once your unit has been received.

Information About Your System

As soon as you open your Sine Wave Plus Long AC Conduit Box package, record the following information and be sure to keep your proof of purchase.

- Serial Number _____
- Purchased From _____
- Purchase Date _____

If you need to contact Customer Service, please record the following details before calling. This information will help our representatives give you better service.

- Type of installation (e.g. residential, mobile) _____
- Length of time inverter has been installed _____
- Battery/battery bank size _____
- Battery type (e.g. flooded, sealed gel cell, AGM) _____
- DC wiring size and length _____
- Alarm sounding? _____
- Description of indicators on front panel _____
- Appliances operating when problem occurred _____
- Description of problem _____

Index

A

- abbreviations and acronyms iv
- AC Bypass Switch Assembly 1–6
- AC conduit box - Long (ACCB-L)
 - introduction 1–2
 - specifications 1–4
- AC disconnect breakers 1–2
- AC load breakers 2–10
- additional accessory wiring 2–29
- additional breakers in the ACCB-L 2–10
- Auxiliary Load Module (ALM), wiring for 2–29

B

- Blockoff Plates (BP-1) 1–7
- breakers 1–4
 - owner-installed 2–10
- bypass switch 1–6
 - AC output OFF 3–4
 - bypass operation 3–3

C

- Code Compliance 2–2
- Customer Service
 - preparing to call WA–4

E

- Emergency Power Off (EPO), wiring for 2–29

G

- Generator Start Module (GSM), wiring for 2–29

I

- Important Safety Instructions v
- Information about Your System form WA–4
- installation
 - additional breakers in ACCB-L 2–10
 - codes 2–2
 - knockout preparation 2–8
 - materials 2–2
 - removing cover 2–6
 - tools 2–2

- inverter

- purchase date WA–4
 - serial number WA–4

- Inverter Communications Adapter (ICA) 2–29

- Inverter Communications Adapter (ICA), wiring for 2–29

- Inverter Control Module (ICM) 2–29

- Inverter Control Module (ICM), wiring for 2–29

- Inverter Stacking Control - Series (ISC-S) cable

- additional accessory wiring 2–29

- grommets for ACCB-L slots 2–6

- ISC-S/ICM cable slots 2–6

K

- Knockout Preparation 2–8

- knockouts

- location on the inverter 2–8

- preparation 2–8

L

- Location 2–4

M

- materials required for installation 2–2

O

- Off-Grid Configurations 2–3

- On-Grid Configurations 2–3

- operation of bypass switch 3–2

P

- preparation for installation 2–2

- proof of purchase WA–4

- purchase date WA–4

S

- serial number WA–4

- specifications for the ACCB-L 1–4

T

tools required for installation 2–2

V

Ventilation Requirements 2–5

W

warranty

 out of warranty service WA–3

 terms and conditions WA–1

wiring

 additional accessories 2–29

X

Xantrex

 web site iv

Xantrex Technology Inc.

1 800 670 0707 Tel toll free NA
1 360 925 5097 Tel direct
1 800 994 7828 Fax toll free NA
1 360 925 5143 Fax direct
customerservice@xantrex.com
www.xantrex.com