

**Models 8751/8754**

# **Pump Style Soft Serve Freezers**

**Operating Instructions**

**056485-M**



2/01/02

**Complete this page for quick reference when service is required:**

Taylor Distributor: \_\_\_\_\_

Address: \_\_\_\_\_

Phone: \_\_\_\_\_

Service: \_\_\_\_\_

Parts: \_\_\_\_\_

Date of Installation: \_\_\_\_\_

**Information found on the data label:**

Model Number: \_\_\_\_\_

Serial Number: \_\_\_\_\_

Electrical Specs: Voltage \_\_\_\_\_ Cycle \_\_\_\_\_

Phase \_\_\_\_\_

Maximum Fuse Size: \_\_\_\_\_ A

Minimum Wire Ampacity: \_\_\_\_\_ A

© February, 2002 Taylor  
All rights reserved.  
056485-M



*The word Taylor and the Crown design  
are registered trademarks in the United States  
of America and certain other countries.*

Taylor Company  
750 N. Blackhawk Blvd.  
Rockton, IL 61072



# Table of Contents

---

|                  |  |    |
|------------------|--|----|
| <b>Section 1</b> | <b>To the Installer</b> .....                          | 1  |
|                  | Water Connections (Water Cooled Units Only) .....      | 1  |
|                  | Air Cooled Units .....                                 | 1  |
|                  | Electrical Connections .....                           | 1  |
| <b>Section 2</b> | <b>To the Operator</b> .....                           | 2  |
|                  | Compressor Warranty Disclaimer .....                   | 2  |
| <b>Section 3</b> | <b>Safety</b> .....                                    | 3  |
| <b>Section 4</b> | <b>Operator Parts Identification</b> .....             | 4  |
|                  | Model 8751 .....                                       | 4  |
|                  | Model 8754 .....                                       | 5  |
|                  | Model 8751 Single Spout Door and Beater Assembly ..... | 6  |
|                  | Model 8754 Three Spout Door and Beater Assembly .....  | 7  |
|                  | Air/Mix Pump .....                                     | 8  |
|                  | Accessories .....                                      | 9  |
| <b>Section 5</b> | <b>Important: To the Operator</b> .....                | 10 |
|                  | Symbol Definitions .....                               | 11 |
|                  | Power Switch .....                                     | 11 |
|                  | Indicator Lights .....                                 | 11 |
|                  | MIX REF Key .....                                      | 11 |
|                  | STANDBY Key .....                                      | 11 |
|                  | WASH Key .....   | 12 |
|                  | AUTO Key .....   | 12 |
|                  | Pump Key .....   | 12 |
|                  | Reset Button .....                                     | 12 |
|                  | Air/Mix Pump Reset Mechanism .....                     | 12 |
|                  | Adjustable Draw Handle .....                           | 12 |
|                  | Feed Tube (Back-up Option) .....                       | 13 |

|                   |   |    |
|-------------------|---|----|
| <b>Section 6</b>  | <b>Operating Procedures</b> .....                 | 14 |
|                   | Assembly .....                                    | 14 |
|                   | Air/Mix Pump Assembly .....                       | 18 |
|                   | Sanitizing .....                                  | 21 |
|                   | Priming .....                                     | 23 |
|                   | Closing Procedure .....                           | 24 |
|                   | Draining Product From the Freezing Cylinder ..... | 25 |
|                   | Rinsing .....                                     | 25 |
|                   | Cleaning .....                                    | 25 |
|                   | Disassembly .....                                 | 26 |
|                   | Brush Cleaning .....                              | 26 |
| <b>Section 7</b>  | <b>Important: Operator Checklist</b> .....        | 27 |
|                   | During Cleaning and Sanitizing .....              | 27 |
|                   | Troubleshooting Bacterial Count .....             | 27 |
|                   | Regular Maintenance Checks .....                  | 27 |
|                   | The Air/Mix Pump Checklist .....                  | 28 |
|                   | Winter Storage .....                              | 28 |
| <b>Section 8</b>  | <b>Troubleshooting Guide</b> .....                | 29 |
| <b>Section 9</b>  | <b>Parts Replacement Schedule</b> .....           | 33 |
| <b>Section 10</b> | <b>Parts List</b> .....                           | 34 |
|                   | Wiring Diagrams .....                             | 44 |

**Note: Continuing research results in steady improvements; therefore, information in this manual is subject to change without notice.**

This machine is designed for indoor use only.



**DO NOT** install the machine in an area where a water jet could be used to clean or rinse the machine. Failure to follow this instruction may result in serious electrical shock.

## Water Connections (Water Cooled Units Only)

An adequate cold water supply must be provided with a hand shut-off valve. On the underside rear of the base pan, two 3/8" I.P.S. (for single-head units) or two 1/2" I.P.S. (for double-head units) water connections for inlet and outlet have been provided for easy hook-up. 1/2" inside diameter water lines should be connected to the machine. (Flexible lines are recommended, if local codes permit.) Depending on local water conditions, it may be advisable to install a water strainer to prevent foreign substances from clogging the automatic water valve. There will be only one water "in" and one water "out" connection for both single-head and double-head units. **DO NOT** install a hand shut-off valve on the water "out" line! Water should always flow in this order: first, through the automatic water valve; second, through the condenser; and third, through the outlet fitting to an **open trap drain**.

## Air Cooled Units

Air cooled units require a minimum of 3" (76 mm) of clearance around all sides of the freezer to allow for adequate air flow across the condenser(s). Failure to allow adequate clearance can reduce the refrigeration capacity of the freezer and possibly cause permanent damage to the compressor.

## Electrical Connections

Each freezer requires one power supply for each data label. Check the data label(s) on the freezer for fuse, circuit ampacity and electrical specifications. Refer to the wiring diagram provided inside of the electrical box, for proper power connections.

In the United States, this equipment is intended to be installed in accordance with the National Electrical Code (NEC), ANSI/NFPA 70-1987. The purpose of the NEC code is the practical safeguarding of persons and property from hazards arising from the use of electricity. This code contains provisions considered necessary for safety. Compliance therewith and proper maintenance will result in an installation essentially free from hazard!

In all other areas of the world, equipment should be installed in accordance with the existing local codes. Please contact your local authorities.

Stationary appliances which are not equipped with a power cord and a plug or other device to disconnect the appliance from the power source must have an all-pole disconnecting device with a contact gap of at least 3 mm installed in the external installation.



**CAUTION: THIS EQUIPMENT MUST BE PROPERLY GROUNDED! FAILURE TO DO SO CAN RESULT IN SEVERE PERSONAL INJURY FROM ELECTRICAL SHOCK!**

Beater rotation must be clockwise as viewed looking into the freezing cylinder of any model freezer.



**Note:** The following procedures should be performed by a trained service technician.

To correct rotation on a three-phase unit, interchange any two incoming power supply lines at freezer main terminal block only.

To correct rotation on a single-phase unit, change the leads inside the beater motor. (Follow diagram printed on motor.)

Electrical connections are made directly to the terminal block provided in the main control box located behind the service panel.

# Section 2

# To the Operator

The freezer you have purchased has been carefully engineered and manufactured to give you dependable operation. The Taylor Company soft-serve models covered in this manual consist of the 8751 and 8754.

These units, when properly operated and cared for, will produce a consistent quality product. Like all mechanical products, they will require cleaning and maintenance. A minimum amount of care and attention is necessary if the operating procedures outlined in this manual are followed closely.

This Operator's Manual should be read before operating or performing any maintenance on your equipment.

Your Taylor freezer will NOT eventually compensate for and correct any errors during the set-up or filling operations. Thus, the initial assembly and priming procedures are of extreme importance. It is strongly recommended that personnel responsible for the equipment's operation, both assembly and disassembly, go through these procedures together in order to be properly trained and to make sure that no confusion exists.

In the event you should require technical assistance, please contact your local authorized Taylor Distributor.



If the crossed out wheeled bin symbol is affixed to this product, it signifies that this product is compliant with the EU Directive as well as other similar legislation in effect after August 13, 2005. Therefore, it must be collected separately after its use is completed, and cannot be disposed as unsorted municipal waste.

The user is responsible for returning the product to the appropriate collection facility, as specified by your local code.

For additional information regarding applicable local laws, please contact the municipal facility and/or local distributor.

## Compressor Warranty Disclaimer

The refrigeration compressor(s) on this machine are warranted for the term indicated on the warranty card accompanying this machine. However, due to the Montreal Protocol and the U.S. Clean Air Act Amendments of 1990, many new refrigerants are being tested and developed, thus seeking their way into the service industry. Some of these new refrigerants are being advertised as drop-in replacements for numerous applications. It should be noted that, in the event of ordinary service to this machine's refrigeration system, **only the refrigerant specified on the affixed data label should be used.** The unauthorized use of alternate refrigerants will void your compressor warranty. It will be the owner's responsibility to make this fact known to any technician he employs.

It should also be noted that Taylor does not warrant the refrigerant used in its equipment. For example, if the refrigerant is lost during the course of ordinary service to this machine, Taylor has no obligation to either supply or provide its replacement either at billable or unbillable terms. Taylor does have the obligation to recommend a suitable replacement if the original refrigerant is banned, obsoleted, or no longer available during the five year warranty of the compressor.

The Taylor Company will continue to monitor the industry and test new alternates as they are being developed. Should a new alternate prove, through our testing, that it would be accepted as a drop-in replacement, then the above disclaimer would become null and void. To find out the current status of an alternate refrigerant as it relates to your compressor warranty, call the local Taylor Distributor or the Taylor Factory. Be prepared to provide the Model/Serial Number of the unit in question.

We at Taylor Company are concerned about the safety of the operator when he or she comes in contact with the freezer and its parts. Taylor has gone to extreme efforts to design and manufacture built-in safety features to protect both you and the service technician. As an example, warning labels have been attached to the freezer to further point out safety precautions to the operator.



**IMPORTANT - Failure to adhere to the following safety precautions may result in severe personal injury. Failure to comply with these warnings may also damage the machine and its components. Component damage will result in part replacement expense and service repair expense.**

### To Operate Safely:



**DO NOT** operate the freezer without reading this operator's manual. Failure to follow this instruction may result in equipment damage, poor freezer performance, health hazards, or personal injury.



- **DO NOT** operate the freezer unless it is properly grounded.
- **DO NOT** attempt any repairs unless the main power supply to the freezer has been disconnected.
- **DO NOT** operate the freezer with larger fuses than specified on the freezer data label.

Failure to follow these instructions may result in electrocution or damage to the machine. Contact your local authorized Taylor Distributor for service.



**DO NOT** use a water jet to clean or rinse the freezer. Failure to follow this instruction may result in serious electrical shock.



- **DO NOT** allow untrained personnel to operate this machine.
- **DO NOT** operate the freezer unless all service panels and access doors are restrained with screws.
- **DO NOT** remove the door, beater and blades, drive shaft, or air/mix pump unless all control switches are in the OFF position.
- **DO NOT** put objects or fingers in door spout.

Failure to follow these instructions may result in contaminated product or severe personal injury to fingers or hands from hazardous moving parts.



**USE EXTREME CAUTION** when removing the beater assembly. The scraper blades are very sharp and may cause injury.



This freezer must be placed on a level surface. Failure to comply may result in personal injury or equipment damage.

**DO NOT** obstruct air intake and discharge openings. The minimum required air space on all sides is 3" (76 mm). Failure to follow this instruction may cause poor freezer performance and damage to the machine.

This freezer is designed to operate indoors, under normal ambient temperatures of 70°-75°F (21°-24°C). The freezer has successfully performed in high ambient temperatures of 104°F (40°C) at reduced capacities.

**NOISE LEVEL:** Airborne noise emission does not exceed 78 dB(A) when measured at a distance of 1.0 meter from the surface of the machine and at a height of 1.6 meters from the floor.

# Section 4

# Operator Parts Identification

Model 8751

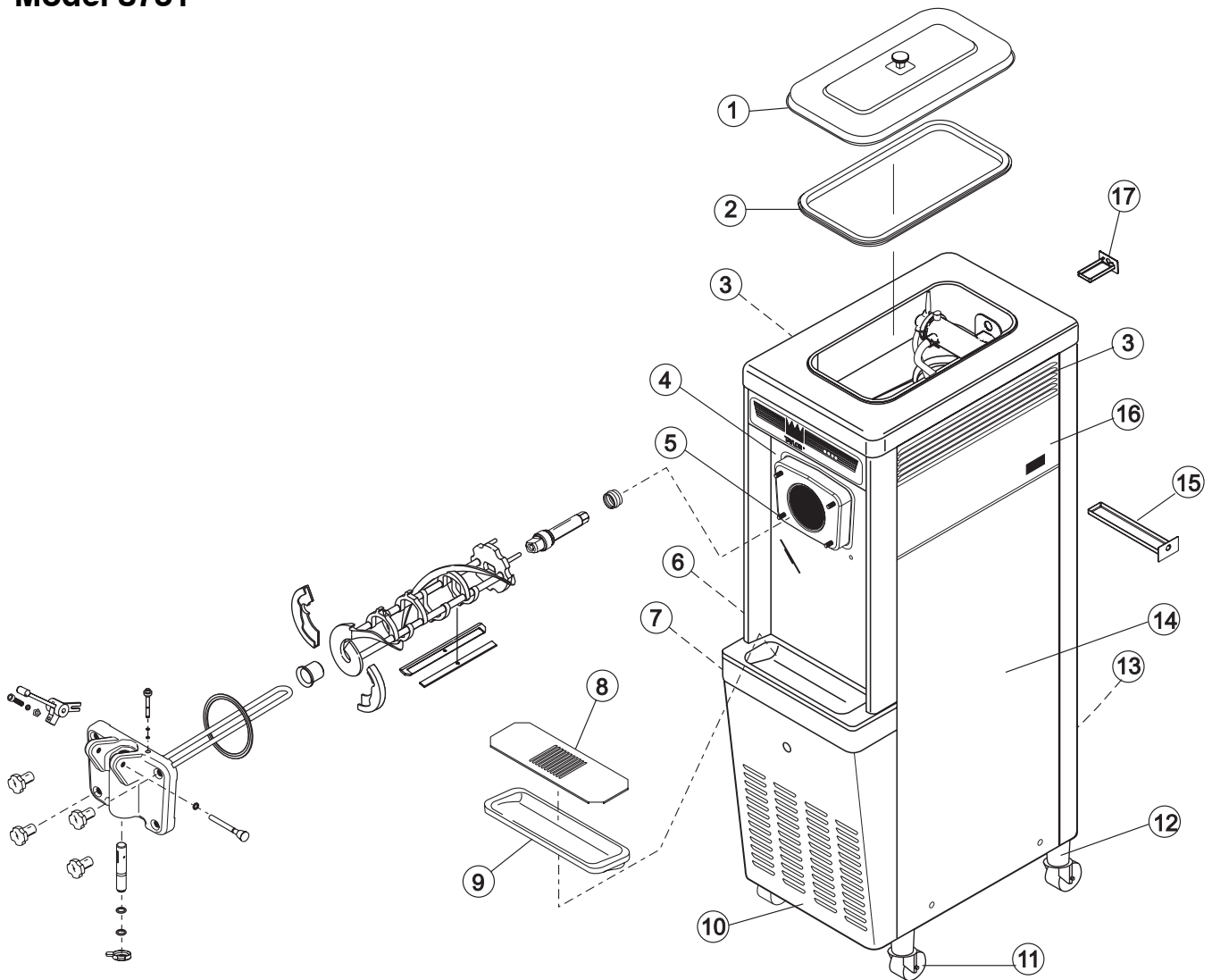

| ITEM | DESCRIPTION               | PART NO. |
|------|---------------------------|----------|
| 1    | COVER A.-HOPPER           | X38458   |
| 2    | GASKET-HOPPER COVER       | 038375   |
| 3    | LOUVER-SIDE               | 017471   |
| 4    | PANEL-A.-FRONT            | X33237   |
| 5    | STUD-NOSE CONE            | 022822   |
| 6    | PANEL-UPPER SIDE          | 024426   |
| 7    | PANEL A.-SIDE-LOWER-LOUV  | X39075   |
| 8    | SHIELD-SPLASH             | 022763   |
| 9    | TRAY- DRIP 14 7/8 X 5 1/8 | 013690   |

| ITEM | DESCRIPTION            | PART NO. |
|------|------------------------|----------|
| 10   | PANEL -SERVICE         | 047170   |
| 11   | CASTER-SWV             | 018794   |
| 12   | ADAPTOR-A.-CASTER      | X18915   |
| 13   | PANEL- REAR            | 048203   |
| 14   | PANEL A.-LOWER SIDE    | X24424   |
| 15   | PAN - DRIP 11 5/8 LONG | 027503   |
| 16   | PANEL-UPPER SIDE RIGHT | 028823   |
| 17   | PAN-DRIP *PUMP         | 048435   |



# Model 8754

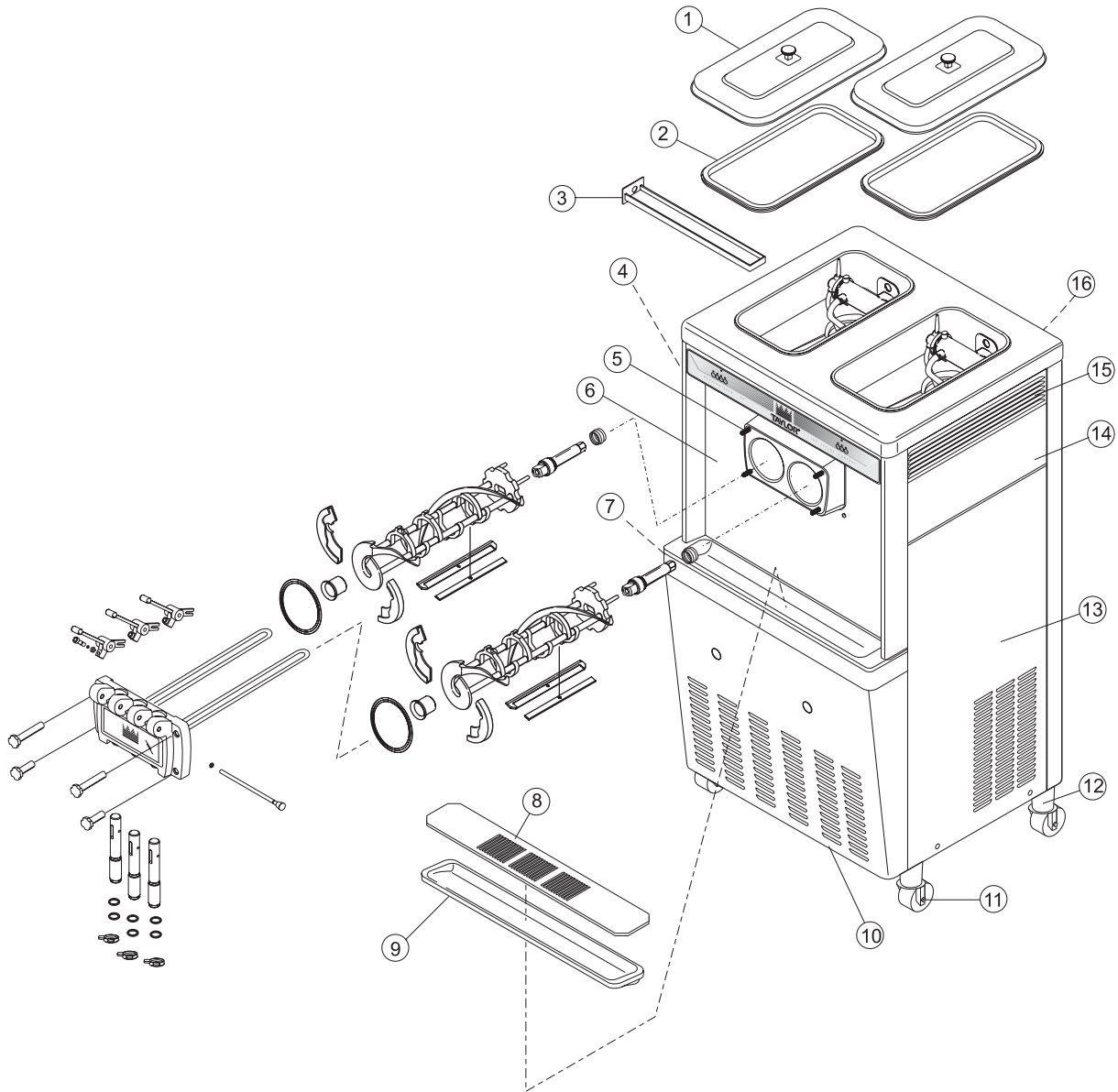

| ITEM | DESCRIPTION            | PART NO. |
|------|------------------------|----------|
| 1    | COVER A.-HOPPER        | X38458   |
| 2    | GASKET-HOPPER COVER    | 038375   |
| 3    | PAN-DRIP 17-1/4"LONG   | 027504   |
| 4    | PANEL-UPPER SIDE L     | 028822   |
| 5    | STUD-NOSE CONE         | 022822   |
| 6    | PANEL A.-FRONT         | X32956   |
| 7    | PANEL A.-SIDE *LOWER L | X46447   |
| 8    | SHIELD-SPLASH          | 022766   |

| ITEM | DESCRIPTION            | PART NO. |
|------|------------------------|----------|
| 9    | TRAY-DRIP              | 014533   |
| 10   | PANEL- SERVICE         | 046584   |
| 11   | CASTER-SWV             | 018794   |
| 12   | ADAPTOR A.-CASTER      | X18915   |
| 13   | PANEL A.-SIDE-LOWER R  | X46448   |
| 14   | PANEL-UPPER SIDE RIGHT | 028823   |
| 15   | LOUVER-SIDE            | 017471   |
| 16   | PANEL- REAR            | 053782   |

# Model 8751 Single Spout Door and Beater Assembly

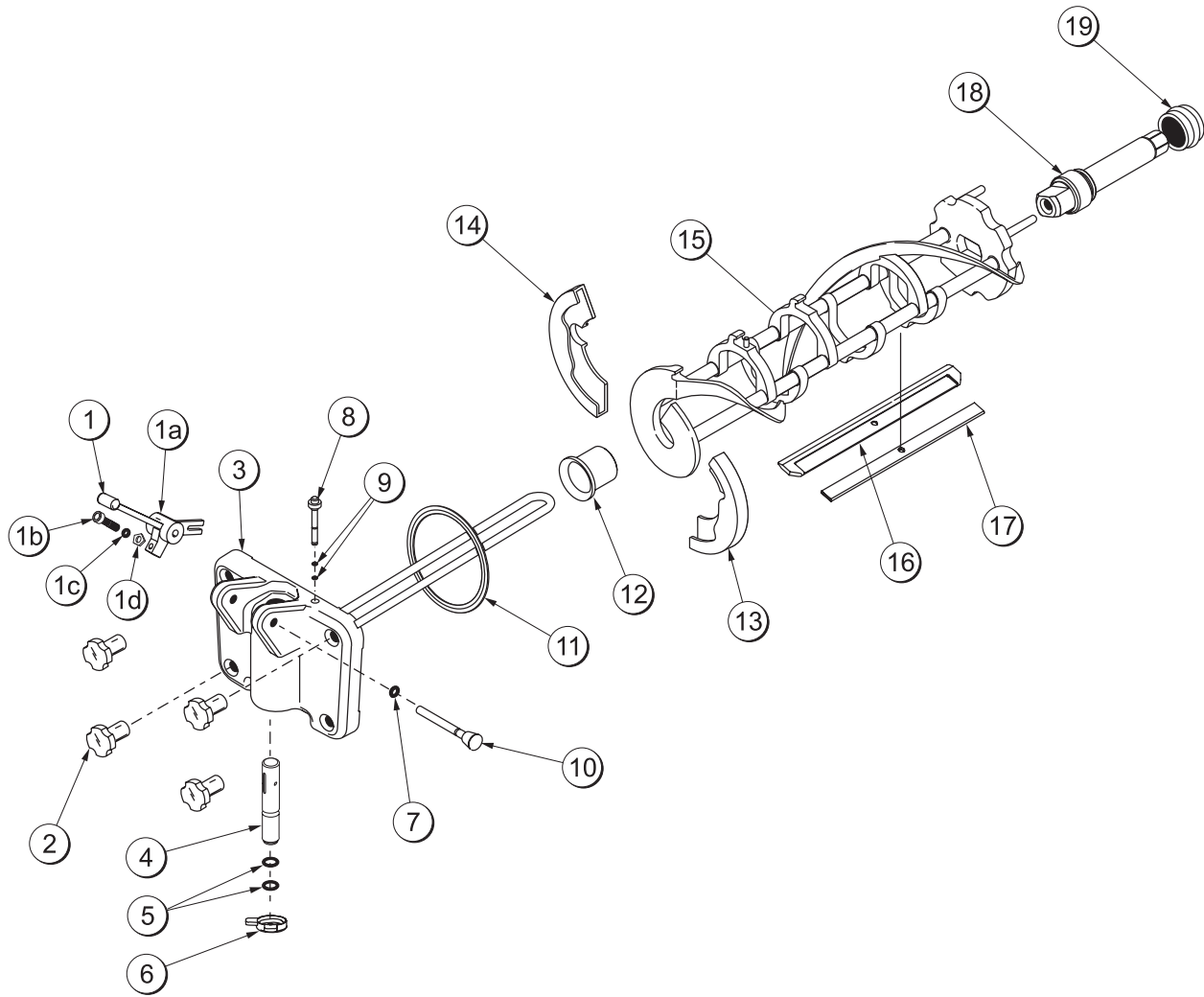

| ITEM | DESCRIPTION                 | PART NO.   |
|------|-----------------------------|------------|
| 1    | HANDLE A.-DRAW-ADJ.         | X55096     |
| 1a   | HANDLE-ADJUSTABLE           | 028804     |
| 1b   | SCREW-ADJUSTMENT            | 055092     |
| 1c   | O-RING-1/4 OD X .070W 50    | 015872     |
| 1d   | NUT-JAM                     | 029639-BLK |
| 2    | NUT-STUD                    | 021508     |
| 3    | DOOR A.-1 SPOUT *VALOX*     | X51531-10  |
| 4    | VALVE A.-DRAW               | X18303     |
| 5    | O-RING-7/8 OD X .103W       | 014402     |
| 6    | CAP-DESIGN-1.010"ID-6 POINT | 014218     |
| 7    | O-RING-5/16 OD X .070W      | 016272     |
| 8    | PLUG-PRIME                  | 028805     |

| ITEM | DESCRIPTION               | PART NO. |
|------|---------------------------|----------|
| 9    | O-RING-3/8 OD X .070W     | 016137   |
| 10   | PIN A.-PIVOT              | X22820   |
| 11   | GASKET-DOOR HT 4"-DOUBLE  | 048926   |
| 12   | BEARING-FRONT-SHOE        | 050348   |
| 13   | SHOE-FRONT HELIX *FRONT*  | 050347   |
| 14   | SHOE-FRONT HELIX *REAR*   | 050346   |
| 15   | BEATER A.-3.4QT-1 PIN     | X46231   |
| 16   | CLIP-SCRAPER-BLADE*7"     | 046236   |
| 17   | BLADE-SCRAPER-PLAS. 8-1/8 | 046235   |
| 18   | SHAFT-BEATER              | 032564   |
| 19   | SEAL-DRIVE SHAFT          | 032560   |

# Model 8754 Three Spout Door and Beater Assembly

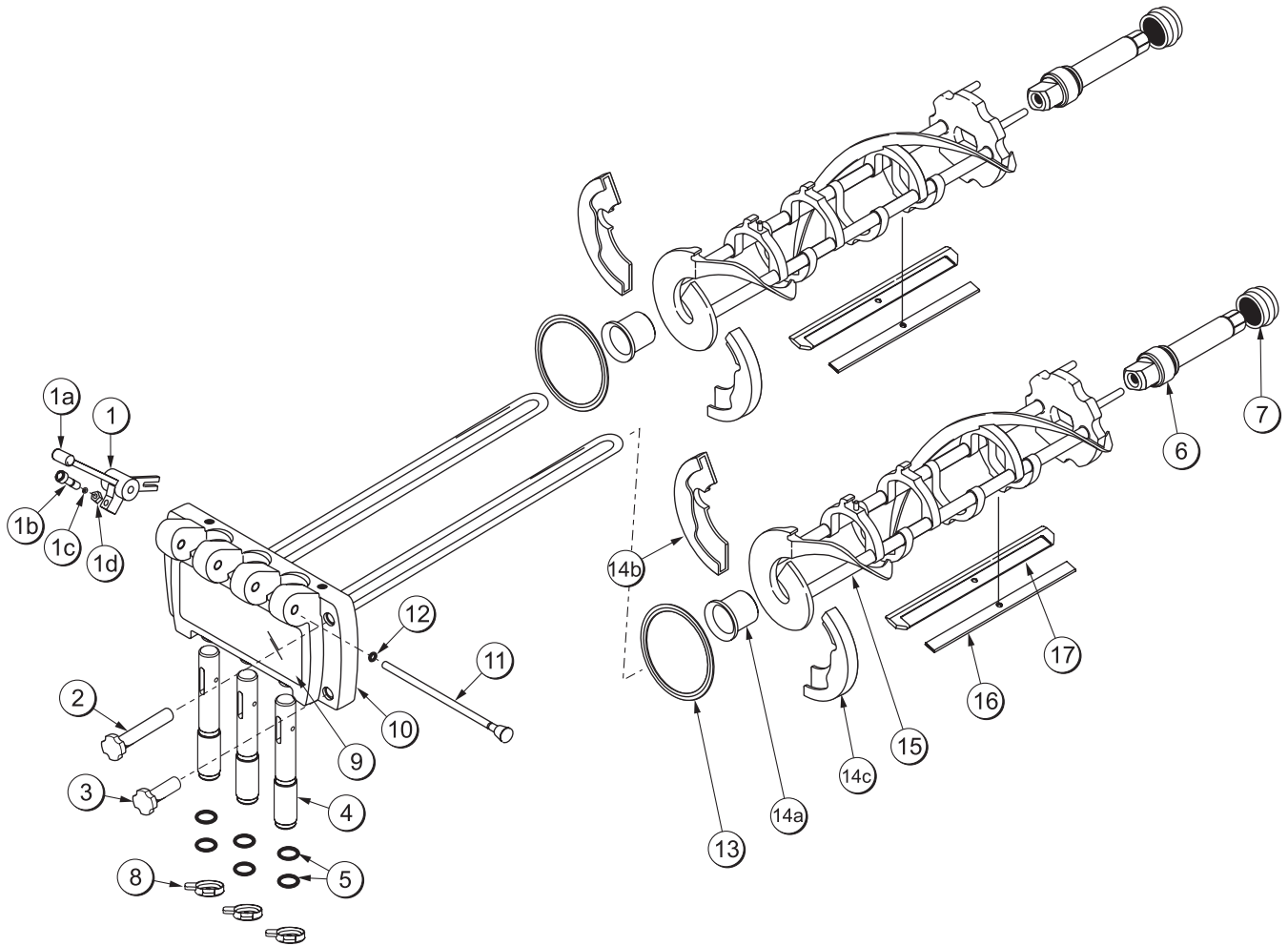

| ITEM | DESCRIPTION          | PART NO.   |
|------|----------------------|------------|
| 1    | HANDLE A.- DRAW      | X55096     |
| 1a   | DRAW HANDLE          | 028804     |
| 1b   | SCREW-ADJUST         | 055092     |
| 1c   | O-RING 1/4OD X .070W | 015872     |
| 1d   | NUT-JAM              | 029639-BLK |
| 2    | NUT-STUD FLAT LONG   | 034382     |
| 3    | NUT-STUD FLAT SHORT  | 034383     |
| 4    | VALVE A.- DRAW       | X18303     |
| 5    | O-RING 7/8OD X .070W | 014402     |
| 6    | SHAFT-BEATER         | 032564     |
| 7    | SEAL-DRIVE SHAFT     | 032560     |
| 8    | CAP-DESIGN           | 014218     |

| ITEM | DESCRIPTION                | PART NO.  |
|------|----------------------------|-----------|
| 9    | DECAL-DOOR                 | 021521    |
| 10   | DOOR A.- 3-SPOUT           | X51532-12 |
| 11   | ROD A.- PIVOT              | X20683    |
| 12   | O-RING 5/16OD X .070W      | 016272    |
| 13   | GASKET-DOOR HT 4"          | 048926    |
| 14a  | BEARING-FRONT              | 050348    |
| 14b  | SHOE-FRONT HELIX *REAR*    | 050346    |
| 14c  | SHOE-FRONT HELIX *FRONT*   | 050347    |
| 15   | BEATER A.-3.4QT-1 PIN      | X46231    |
| 16   | BLADE-SCRAPER-PLASTIC      | 046235    |
| 17   | CLIP-SCRAPER-BLADE*7.00-IN | 046236    |

# Air/Mix Pump

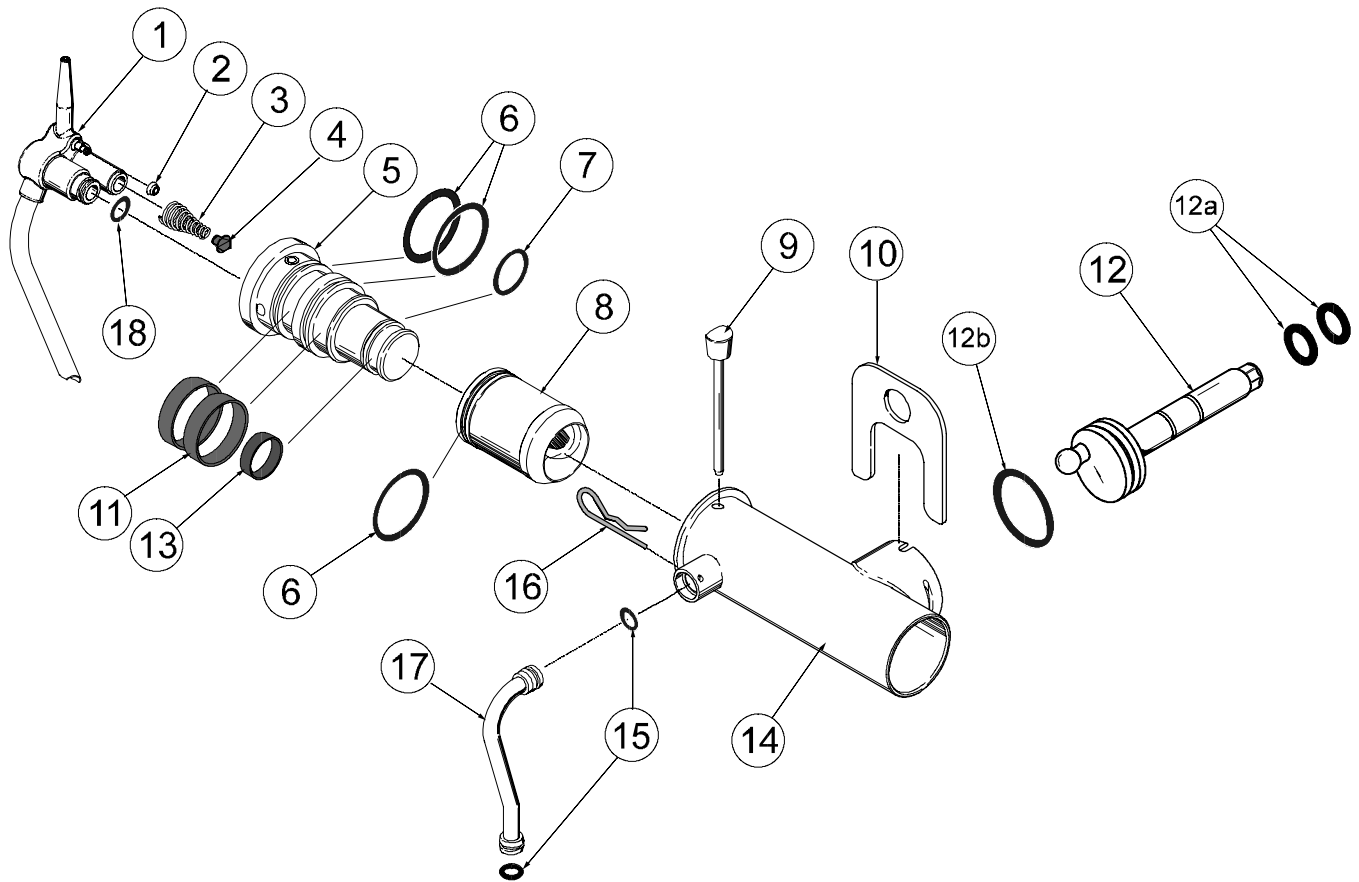

| ITEM | DESCRIPTION              | PART NO. |
|------|--------------------------|----------|
| 1    | TUBE A.-MIX INLET-HOPPER | X45318   |
| 2    | SEAL-AIR INLET FITTING   | 045327   |
| 3    | SPRING-TAPERED 1-7/8     | 022456   |
| 4    | POPPET-RUBBER BLACK      | 022473   |
| 5    | BODY A.-COAX VALVE       | X46860-B |
| 6    | O-RING 2-1/8 OD X .139 W | 020051   |
| 7    | O-RING 1-3/8 OD X .103 W | 018664   |
| 8    | PISTON-COAX PUMP         | 045319-B |
| 9    | PIN A.-COAX PUMP HT SS   | X36950   |
| 10   | CLIP-MIX PUMP RETAINER   | 044641   |
| 11   | RING-CHECK 2" OD X 1/2   | 020050   |
| 12   | SHAFT A.-DRIVE MIX PUMP  | X39084   |

| ITEM | DESCRIPTION                       | PART NO. |
|------|-----------------------------------|----------|
| 12a  | O-RING 1/2 ID X .139 W-206        | 048632   |
| 12b  | O-RING 1-3/4 OD X .139 W          | 008904   |
| 13   | RING-CHECK 1-1/4 OD X 3/8         | 033215   |
| 14   | CYLINDER A.-PUMP HT               | X44755   |
| 15   | O-RING 11/16 OD X .103 W-RED      | 016132   |
| 16   | PIN-COTTER HAIRPIN 1/8 DIA.       | 044731   |
| 17   | TUBE A.-FEED-HPR PUMP SS L (8754) | X44662   |
|      | TUBE A.-FEED-HPR PUMP SS R (8754) | X44664   |
|      | TUBE A.-HT PUMP FEED SS (8751)    | X44666   |
| 18   | O-RING 3/4 OD X .103 W            | 015835   |

# Accessories

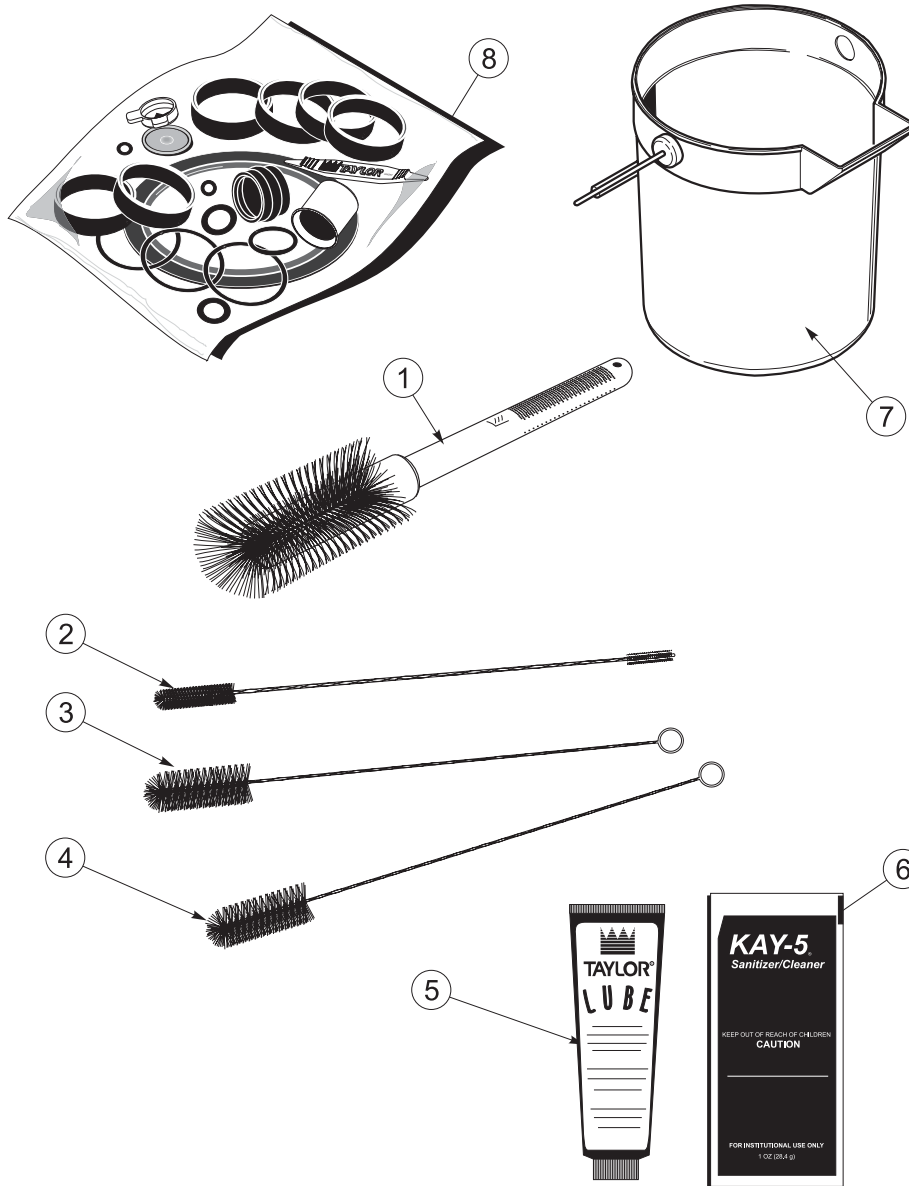

| ITEM | DESCRIPTION            | PART NO. |
|------|------------------------|----------|
| 1    | BRUSH-MIX PUMP BODY    | 023316   |
| 2    | BRUSH-DOUBLE ENDED     | 013072   |
| 3    | BRUSH-REAR BEARING     | 013071   |
| 4    | BRUSH-DRAW VALVE       | 013073   |
| 5    | LUBRICANT-TAYLOR 4 OZ. | 047518   |

| ITEM | DESCRIPTION                 | PART NO.  |
|------|-----------------------------|-----------|
| 6    | SANITIZER-KAY 5 (125 PKTS)  | 041082    |
| 7    | PAIL-MIX 10 QT.             | 013163    |
| 8    | KIT A.-TUNE UP (MODEL 8751) | X49463-9  |
|      | KIT A.-TUNE UP (MODEL 8754) | X49463-19 |

# Section 5

# Important: To the Operator

8751

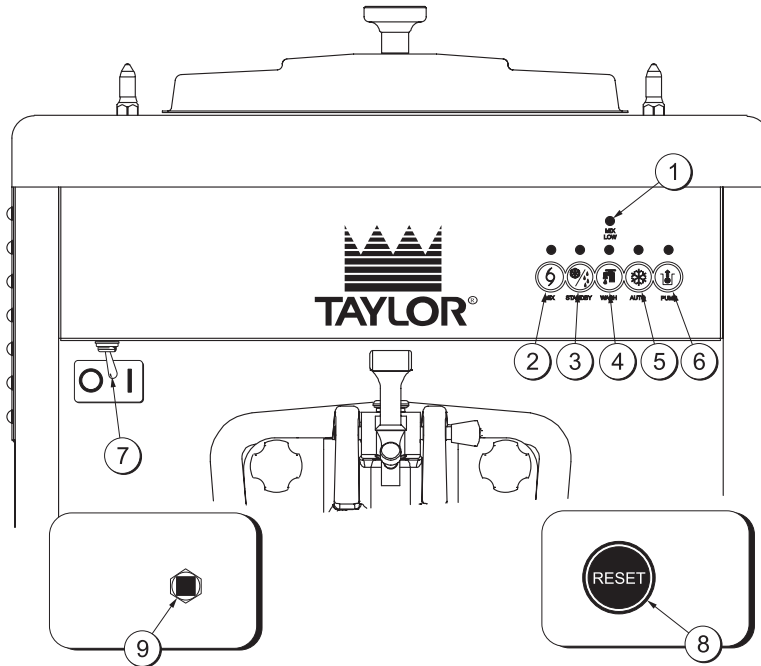

8754

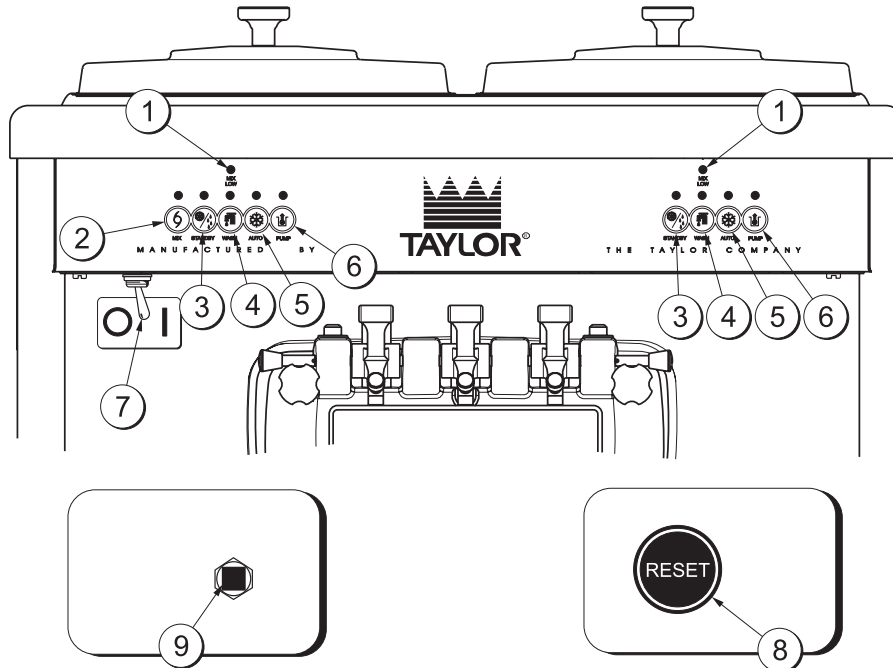

| ITEM | DESCRIPTION             |
|------|-------------------------|
| 1    | MIX LOW INDICATOR LIGHT |
| 2    | MIX REFRIGERATOR KEY    |
| 3    | STANDBY KEY             |
| 4    | WASH KEY                |
| 5    | AUTO KEY                |

| ITEM | DESCRIPTION                 |
|------|-----------------------------|
| 6    | PUMP KEY                    |
| 7    | POWER ON/OFF (TOGGLE)       |
| 8    | RESET BUTTON - BEATER MOTOR |
| 9    | RESET BUTTON - PUMP         |

## Symbol Definitions

To better communicate in the International arena, symbols have replaced words on many of our operator switches, function, and fault indicators. Your Taylor equipment is designed with these International symbols.

The following chart identifies the symbol definitions.

|  |           |
|--|-----------|
|   | = OFF     |
|   | = ON      |
|   | = MIX     |
|   | = STANDBY |
|   | = WASH    |
|   | = AUTO    |
|  | = PUMP    |

## Power Switch

When placed in the ON position, the power switch allows SOFTECH control panel operation.

## Indicator Lights

Located on the front of the machine is a mix level indicating light. When the light begins to flash, it indicates that the mix hopper has a low supply of mix and should be refilled as soon as possible. Always maintain at least 3" (76 mm) of mix in the hopper. If you neglect to add mix, a freeze-up may occur. This will cause eventual damage to the beater, blades, drive shaft, and freezer door.

## MIX REF Key

When the MIX REF key is pressed, the light comes on indicating the mix hopper refrigeration system is operating. For the Model 8754 the MIX REF is controlled by the left side of the freezer as viewed from the operator end. The MIX REF function cannot be cancelled unless the AUTO or STANDBY modes are cancelled first.

## STANDBY Key

The Separate Hopper Refrigeration System (SHR) and the Cylinder Temperature Retention System (CTR) are standard features. The SHR incorporates the use of a separate small refrigeration system to maintain the mix in the hopper below 40° (4.4°C) to assure bacteria control. The CTR works with the SHR to maintain a good quality product. During long "No Sale" periods, it is necessary to warm the product in the freezing cylinder to approximately 35°F to 40°F (1.7°C to 4.4°C) to prevent overbeating and product breakdown.

To activate the SHR and CTR, press the STANDBY key. Remove the air orifice and place the air tube (**end without the hole**) into the mix inlet hole.

When the STANDBY key is pressed, the light comes on, indicating the CTR (Cylinder Temperature Retention System) has been activated. In the STANDBY mode, the WASH and AUTO functions are automatically cancelled. The MIX REF function is automatically locked in to maintain the mix in the hopper.

To resume normal operation, press the AUTO key. When the unit cycles off, the product in the freezing cylinder will be at serving viscosity. At this time, place the air tube (**end with the hole**) into the mix inlet hole and install the air orifice.

## WASH Key

When the WASH key is pressed, the light comes on. This indicates beater motor operation. The STANDBY or AUTO modes must be cancelled first to activate the WASH mode.

## AUTO Key

When the AUTO key is pressed, the light comes on. This indicates that the main refrigeration system has been activated. In the AUTO mode, the WASH or STANDBY functions are automatically cancelled. The MIX REF function is automatically locked in to maintain the mix in the mix hopper.

**Note:** An indicating light and an audible tone will sound whenever a mode of operation has been pressed. To cancel any function, press the key again. The light and mode of operation will shut off.

## Pump Key

When the PUMP key is pressed, the light comes on, indicating the air/mix pump will operate as required.

## Reset Button

The reset button is located in the service panel on the front of the machine. The reset protects the beater motor from an overload condition. If an overload occurs, the reset mechanism will trip. To properly reset the freezer, press the AUTO key to cancel the cycle. Turn the power switch to the OFF position. Press the reset button firmly.



**Do not use metal objects to press the reset button. Failure to follow this instruction may result in electrocution.**

Turn the power switch to the ON position. Press the WASH key and observe the freezer's performance. Open the side access panel. Make sure the beater motor is turning the drive shaft in a clockwise direction (from the operator end) without binding.

If the beater motor is turning properly, press the WASH key to cancel the cycle. Press the AUTO key to resume normal operation. If the freezer shuts down again, contact a service technician. (For the Model 8754 press the AUTO key on both sides of the unit to resume normal operation.)

## Air/Mix Pump Reset Mechanism

The reset button for the pump is located in the service panel. The reset protects the pump from an overload condition. Should an overload occur, the reset mechanism will trip. To reset the pump, press the reset button firmly.

## Adjustable Draw Handle

These units feature an adjustable draw handle to provide the best portion control. The draw handle should be adjusted to provide a flow rate of 5 to 7-1/2 oz. (148 to 222 ml) of product per 10 seconds. To INCREASE the flow rate, turn the screw COUNTERCLOCKWISE. Turn the screw CLOCKWISE to DECREASE the flow rate. During "Sanitizing" and "Rinsing", the flow rate can be increased by removing the pivot pin and placing the restrictive bar on the TOP. When drawing product, **always** place the restrictive bar on the bottom.

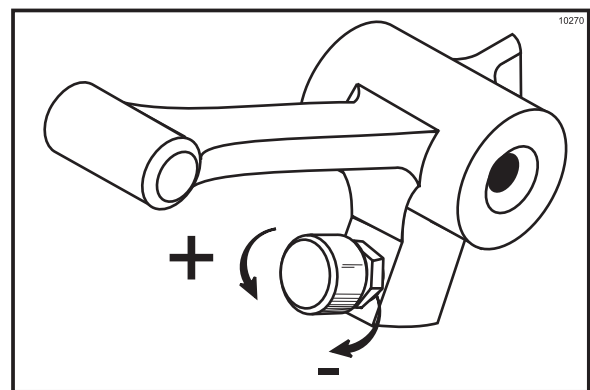

Figure 1

**IMPORTANT: Once the draw rate is set, tighten the lock nut with a wrench.**



## Feed Tube (Back-up Option)

If the air/mix pump has become inoperable because of a missing or damaged part, the operator can temporarily operate the unit using the feed tube. The product ejection rate will be slower when the feed tube is used instead of the air/mix pump.

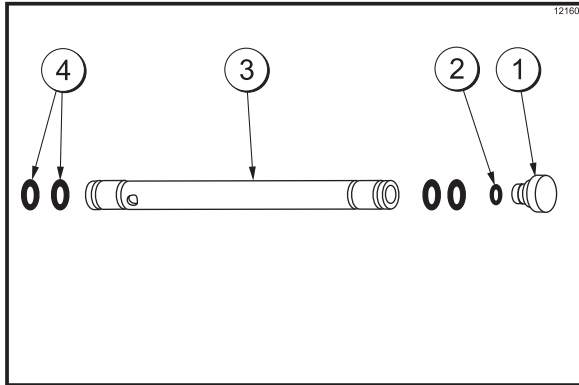

Figure 2

| ITEM | DESCRIPTION               | PART NO.   |
|------|---------------------------|------------|
| 1    | ORIFICE                   | 022465-100 |
| 2    | O-RING-3/8 OD X .070 W    | 016137     |
| 3    | TUBE A.-FEED-SS 5/32 HOLE | X29429-2   |
| 4    | O-RING-.643 OD X .077 W   | 018572     |

The feed tube serves two purposes. One end of the tube has a hole and the other end does not.

### 1. Normal Operation

During normal operation, the end of the feed tube with the hole is placed into the mix inlet hole. Every time the draw handle is raised, new mix and air from the hopper flow into the freezing cylinder. This keeps the freezing cylinder properly loaded and maintains overrun.

### 2. Long “No Sale” Periods

During long “No Sale” periods, the unit can be placed into the Standby mode. This maintains product temperatures below 40°F (4.4°C) in both the hopper and the freezing cylinder, and helps prevent overbeating and product breakdown.

To place the unit into the Standby mode, press the STANDBY key. Remove the air orifice. Lubricate the o-rings located on the end of the feed tube without the hole. Place that end of the tube into the mix inlet hole. This will prevent any mix from entering the freezing cylinder.

**Note:** The air orifice is used to meter a certain amount of air into the freezing cylinder. The air orifice maintains overrun and allows enough mix to enter the freezing cylinder after a draw.

# Section 6

# Operating Procedures

The Model 8751 has been selected to illustrate the step-by-step operating procedures for both models contained in this manual. These models, for all practical purposes of operation, are the same.

Each unit stores mix in a hopper. The mix is pumped into the freezing cylinder. They have 3.4 quart (3.2 liter) capacity freezing cylinders and 20 quart (18.9 liter) mix hoppers.

Duplicate the following procedures, where they apply, for the second freezing cylinder on the Model 8754.

We begin our instructions at the point where we enter the store in the morning and find the parts disassembled and laid out to air dry from the previous night's cleaning.

These opening procedures will show you how to assemble these parts into the freezer, sanitize them, and prime the freezer with fresh mix in preparation to serve your first portion.

If you are disassembling the machine for the first time or need information to get to this starting point in our instructions, turn to page 26, "Disassembly", and start there.

## Assembly

**Note:** When lubricating parts, use an approved food grade lubricant (example: Taylor Lube).



**MAKE SURE POWER SWITCH IS IN THE "OFF" POSITION!** Failure to follow this instruction may result in severe personal injury from hazardous moving parts.

### Step 1

**Install the drive shaft.** Lubricate the groove and shaft portion that comes in contact with the bearing on the beater drive shaft. Slide the seal over the shaft and groove until it snaps into place. **DO NOT** lubricate the hex end of the drive shaft.

Fill the inside portion of the seal with 1/4" more lubricant and lubricate the flat side of the seal that fits onto the rear shell bearing.

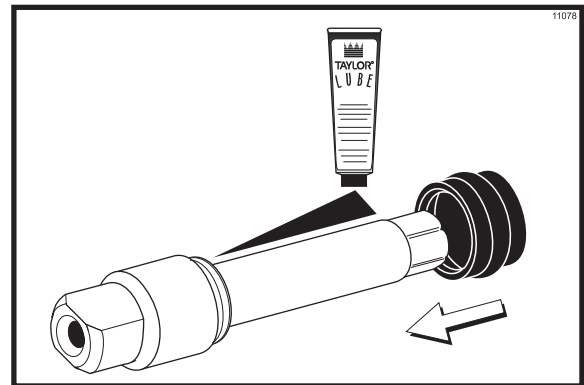

Figure 3

Insert the drive shaft into the freezing cylinder, hex end first, and into the rear shell bearing until the seal fits securely over the rear shell bearing. Engage the hex end firmly into the drive coupling. Be sure the drive shaft fits into the drive coupling without binding.

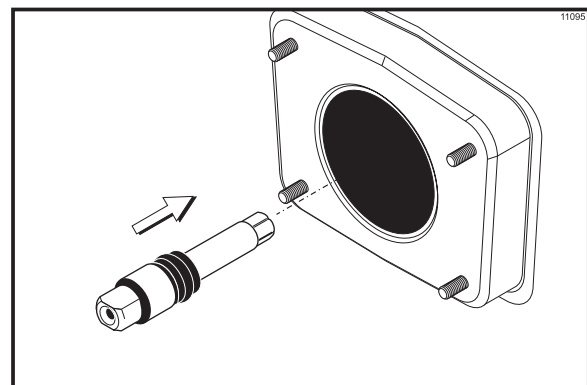

Figure 4

## Step 2

**Install the beater assembly.** First check the scraper blades for any nicks or signs of wear. If any nicks are present, or if the blades are worn, replace both blades. If the blades are in good condition, install the scraper blade clips on the scraper blades. Place the rear scraper blade over the rear holding pin on the beater.

**Note:** The hole on the scraper blade must fit securely over the pin to prevent costly damage.

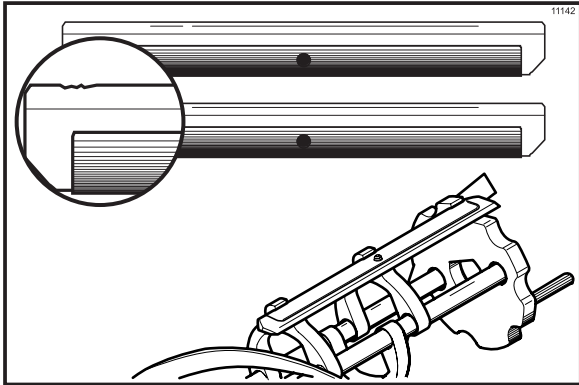

Figure 5

Holding the rear blade on the beater, slide it halfway into the freezing cylinder. Install the front scraper blade over the front holding pin.

Install the beater shoes.

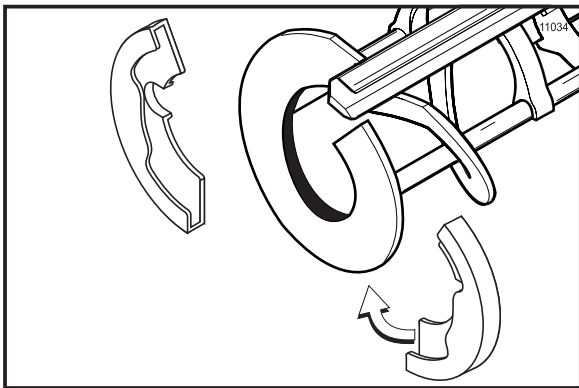

Figure 6

Slide the beater assembly the rest of the way into the freezing cylinder.

Make sure the beater assembly is in position over the drive shaft. Turn the beater slightly to be certain that the beater is properly seated. When in position, the beater will not protrude beyond the front of the freezing cylinder.

**Repeat steps 1 and 2** for the other side of the freezer on the Model 8754.

## Step 3

**Assemble the freezer door.** Place the large rubber gasket(s) into the groove(s) on the back side of the freezer door.

Slide the white plastic front bearing(s) over the baffle rod(s) onto the bearing hub(s) making certain that the flanged end of the bearing is resting against the freezer door. **DO NOT LUBRICATE THE GASKET(S) OR THE FRONT BEARING(S).**

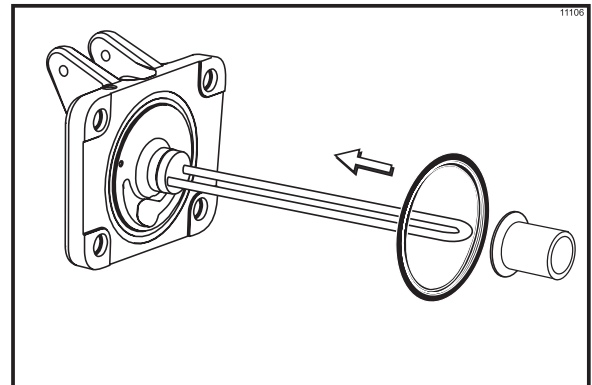

Figure 7

**Note:** There are two gaskets and two front bearings for the Model 8754 door, one for each freezing cylinder.

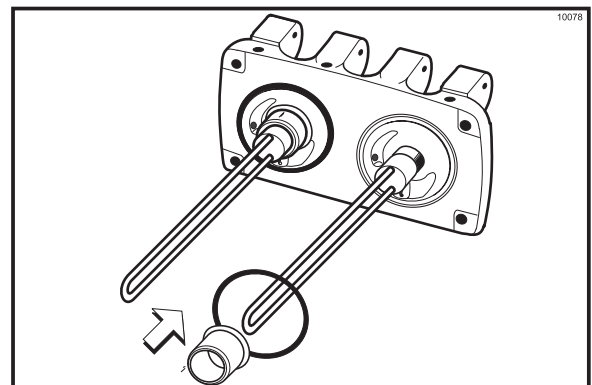

Figure 8

Slide the two o-rings into the grooves on the prime plug(s). Apply an even coat of Taylor Lube to the o-rings and shaft(s).

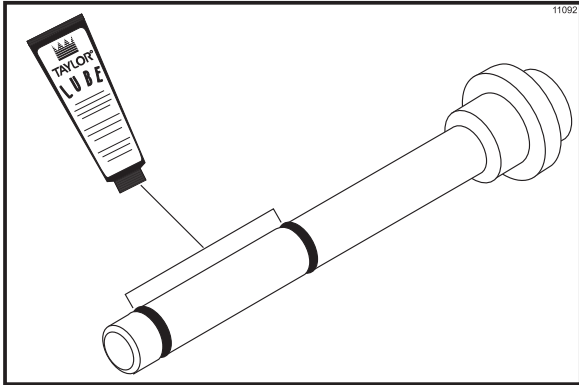

Figure 9

**Note:** There are two prime plugs for the Model 8754 door, one for each freezing cylinder.

Insert the prime plug(s) into the hole(s) in the top of the freezer door, and push down.

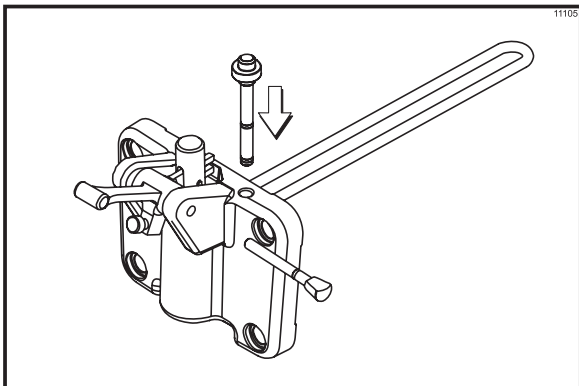

Figure 10

**Step 4**  
**Install the freezer door.** Insert the baffle rod(s) through the opening in the beater(s) and seat the door flush with the freezing cylinder. With the door seated on the freezer studs, install the handscrews. Tighten equally in a crisscross pattern to insure the door is snug.

**Note:** On the Model 8754, the short handscrews go on the bottom and the long handscrews go on the top.

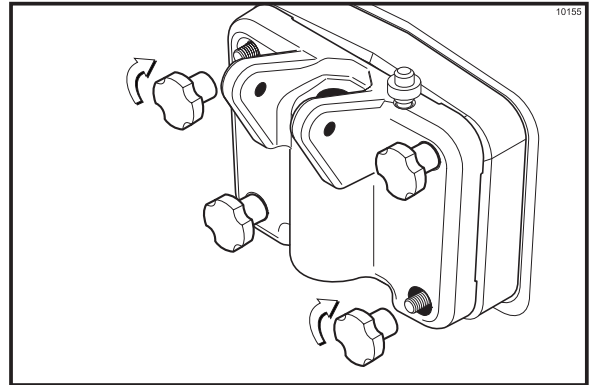

Figure 11

**Step 5**  
**Install the draw valve(s).** Slide the two o-rings into the grooves on the draw valve(s), and lubricate.

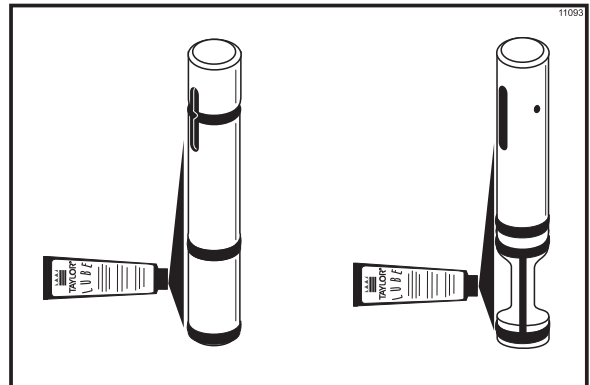

Figure 12

**Note:** The Model 8754 has three draw valves.

Lubricate the inside of the freezer door spout(s), top and bottom, and insert the draw valve(s) from the **bottom** until the slot in the draw valve(s) comes into view.

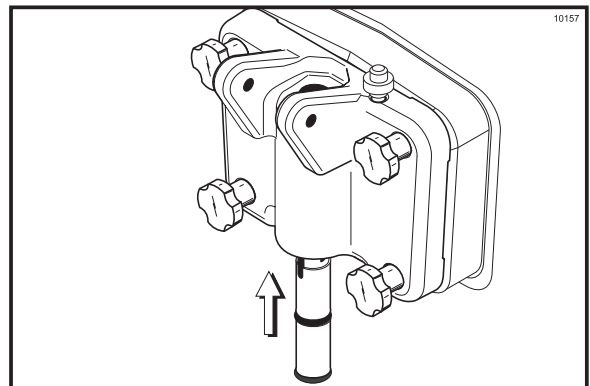

Figure 13

### Step 6

Install the adjustable draw handle(s). Slide the o-ring into the groove on the pivot pin, and lubricate.

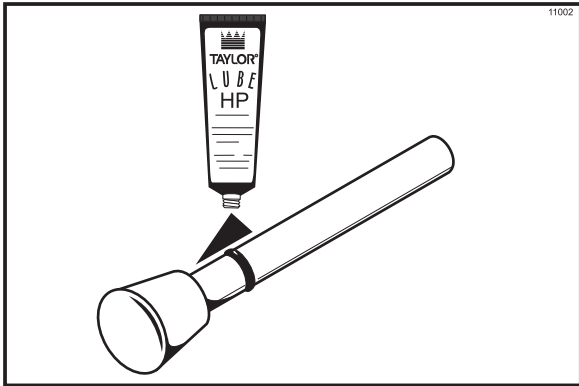

Figure 14

Slide the fork over the bar in the slot of the draw valve. Secure with pivot pin.

**Note:** The Model 8754 has three draw handles. Slide the fork of the draw handle in the slot of the draw valve, starting from the right. Slide the pivot pin through each draw handle as you insert them into the draw valves.

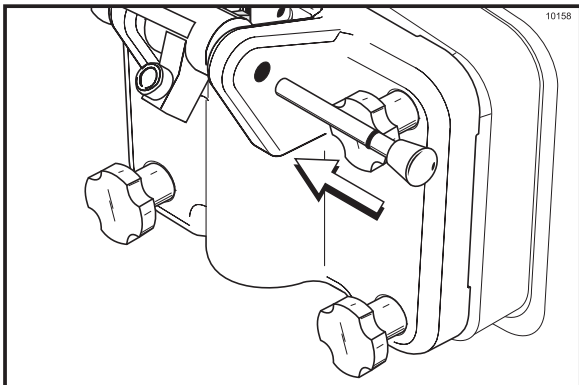

Figure 15

**Note:** These units feature adjustable draw handles to provide the best portion control. The draw handles can be adjusted for different flow rates. See page 12 for more information on adjusting these handles.

### Step 7

Snap the design cap(s) over the end of the door spout(s).

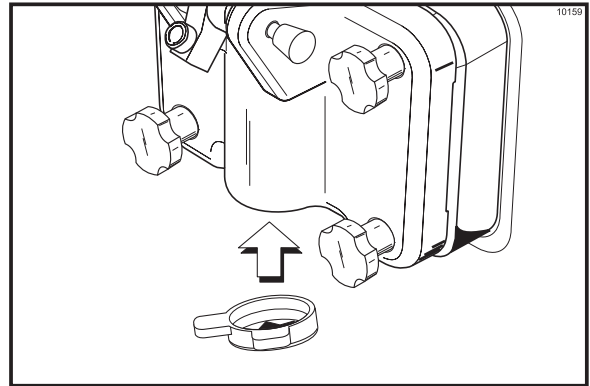

Figure 16

### Step 8

Install the front drip tray and the splash shield under the door spout(s).

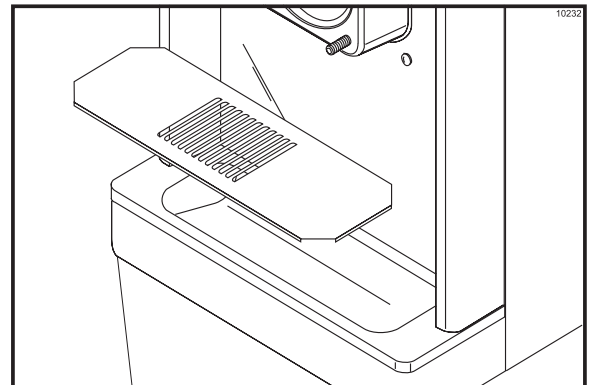

Figure 17

### Step 9

Slide the rear drip pan into the hole in the side panel. Slide the pump drip pan into the hole in the back panel (Model 8751 only).

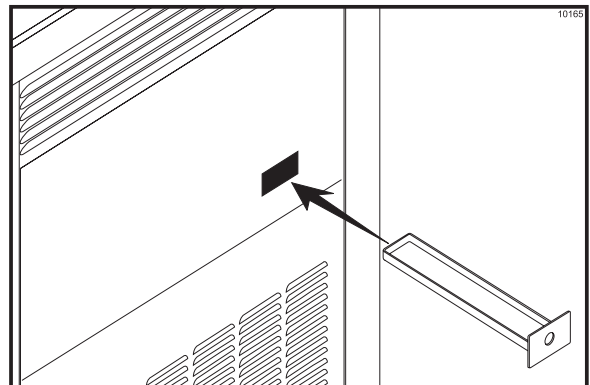

Figure 18

## Air/Mix Pump Assembly

The purpose of the air/mix pump is to meter a specific amount of air and mix, and to transfer this combination to the freezing cylinder.

Refer to the illustration on page 8 for identification of parts during assembly.

### Step 1

Assemble the piston. Slide the o-ring into the groove on the piston. **DO NOT** lubricate this o-ring.

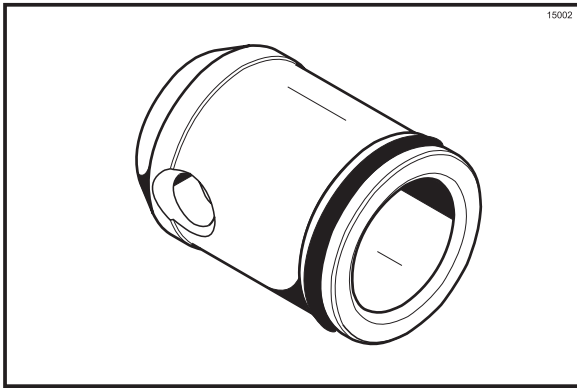

Figure 19

### Step 2

Assemble the liquid valve body. Slide the three check bands and three o-rings into the grooves on the liquid valve body. **DO NOT** lubricate the check bands or o-rings.

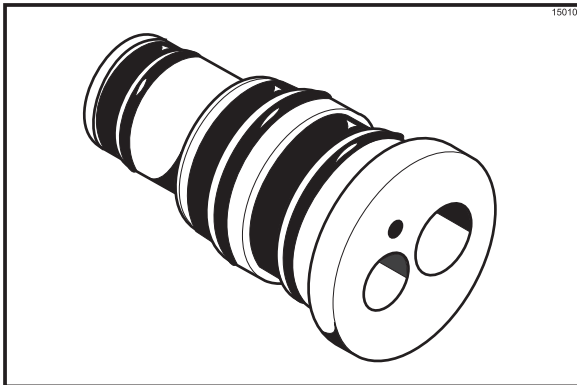

Figure 20

**Note:** Check bands have two smooth surfaces. A concave shape indicates an incorrect assembly. Turn the check band inside out to correctly expose the flat surface.

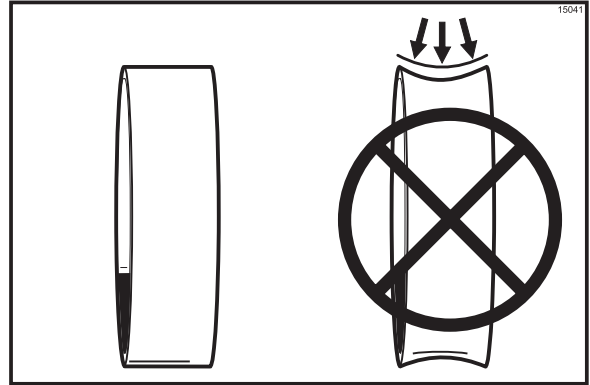

Figure 21

### Step 3

Put a small amount of lubricant on the inside diameter of the piston. Insert the narrow end of the liquid valve body into the open end of the piston.

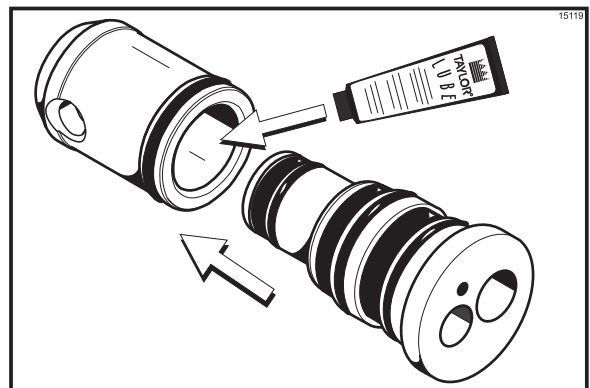

Figure 22

#### Step 4

Apply a small amount of lubricant to the LOWER inside diameter of the pump cylinder to a depth equivalent to the length of your index finger. Once applied, the amount of lubricant should be equal to a paper-thin film.

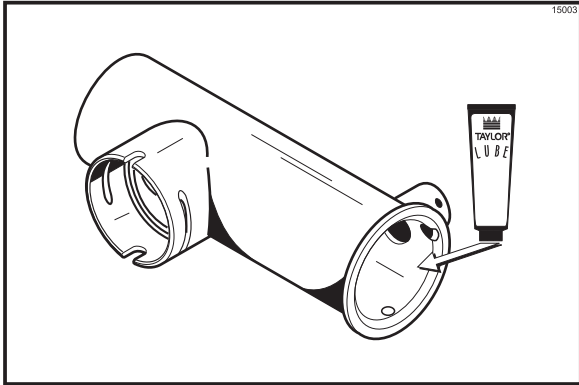

Figure 23

Insert the assembled piston and liquid valve body into the pump cylinder and push upwards. Align the steel button at the base of the valve body with the cut-out groove at the bottom of the pump cylinder.

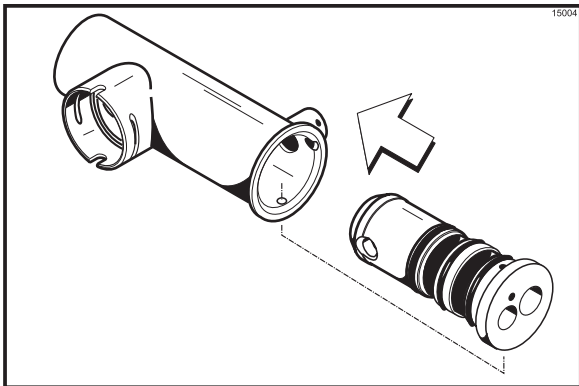

Figure 24

**Note:** The hole in the piston must be visible through the drive hole in the pump cylinder.

#### Step 5

Assemble the mix inlet tube assembly. Slide the o-ring and the seal into the grooves on the fittings, and thoroughly lubricate these parts.

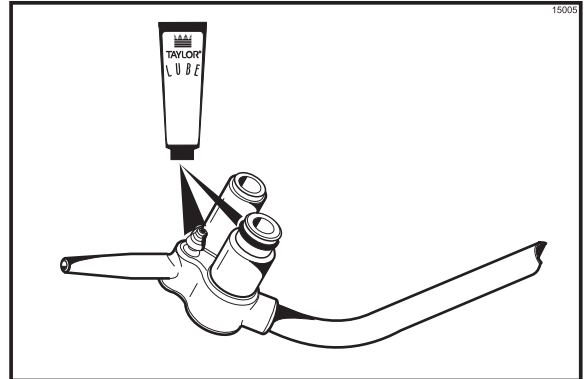

Figure 25

#### Step 6

Put the rubber poppet into the small end of the spring. Attach the spring and poppet to the end of the pressure relief fitting. The spring and poppet must be securely fastened and must not be allowed to float freely.

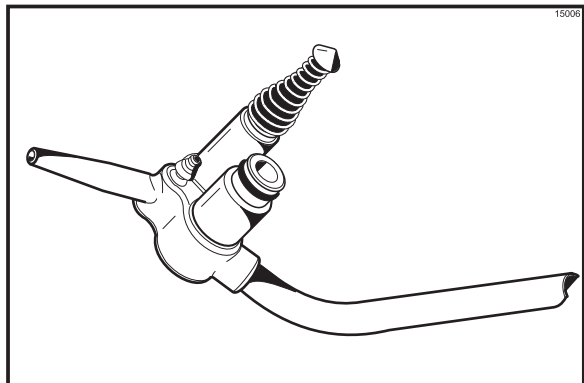

Figure 26

**Note:** The rubber poppet and spring act as a pressure relief valve to prevent a pressure build up in the freezing cylinder.

Insert the assembled mix inlet tube into the hole in the base of the liquid valve body.

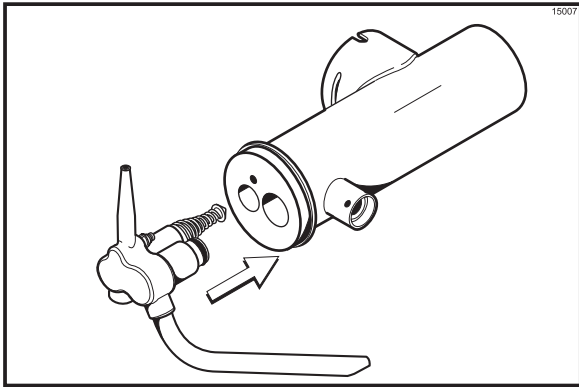

Figure 27

Secure the pump parts in position by sliding the retaining pin through the cross holes located at the bottom of the pump cylinder.

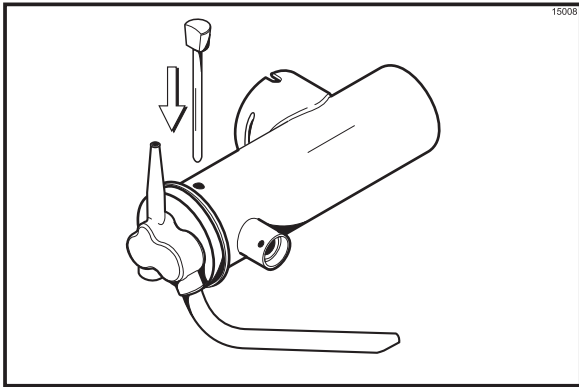

Figure 28

**Note:** When the pump is correctly installed, the head of the retaining pin should be facing up.

**Step 7**

Install one o-ring on each end of the mix feed tube. Thoroughly lubricate.

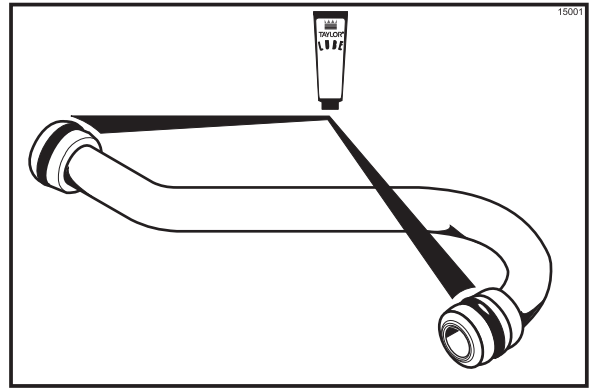

Figure 29

**Step 8**

Slide the large o-ring and two small o-rings into the grooves on the drive shaft. Thoroughly lubricate the o-rings, and the shaft. **DO NOT** lubricate the hex end of the shaft.

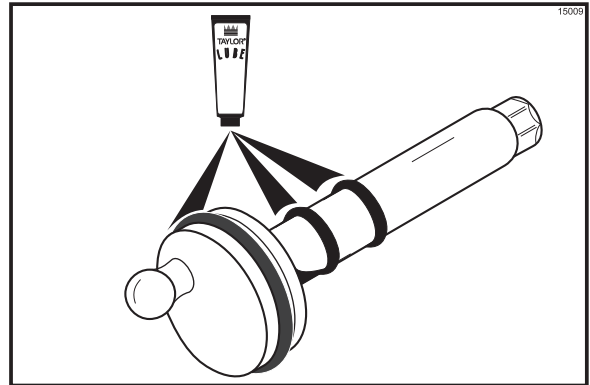

Figure 30



Install the hex end of the drive shaft into the drive hub at the rear wall of the mix hopper.

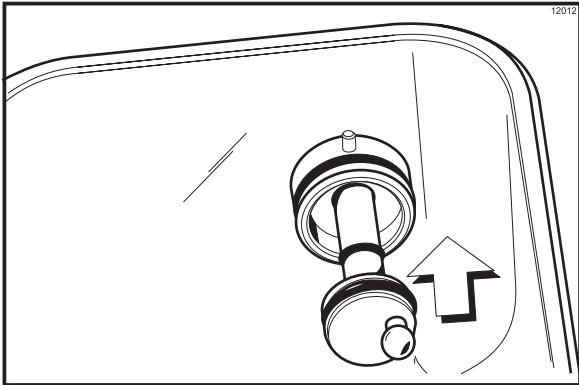

Figure 31

**Note:** For ease in installing the pump, position the ball crank of the drive shaft in the 3 o'clock position.

**Step 9**

Lay the pump assembly, pump clip, mix feed tube, locking clip, and gasket in the bottom of the mix hopper for sanitizing.

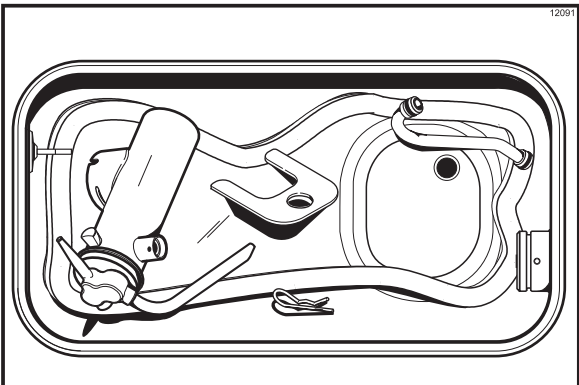

Figure 32

**Repeat Steps 1 through 9** for the other side of the freezer on the Model 8754.

## Sanitizing

**Step 1**

Prepare two gallons (7.6 liters) of an approved 100 PPM sanitizing solution (example: Kay-5®). USE WARM WATER AND FOLLOW THE MANUFACTURER'S SPECIFICATIONS.

**Step 2**

Pour the two gallons (7.6 liters) of sanitizing solution over all the parts in the bottom of the mix hopper and allow it to flow into the freezing cylinder.

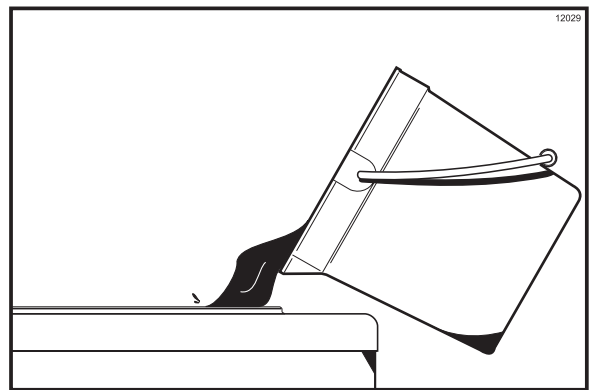

Figure 33

**Note:** You have just sanitized the mix hopper and parts; therefore, be sure your hands are clean and sanitized before going on in these instructions.

**Step 3**

While the solution is flowing into the freezing cylinder, take particular care to brush-clean the mix level sensing probe on the front wall and the bottom of the hopper, the mix hopper, the mix hopper gasket, the mix inlet hole, the air/mix pump, the pump clip, the mix feed tube, and the locking clip.

**Step 4**

Install the pump assembly. To position the pump on the drive hub at the rear of the mix hopper, align the drive hole in the piston with the drive crank of the drive shaft. Secure the pump in place by slipping the pump clip over the collar of the pump, making sure the clip fits into the grooves in the collar.

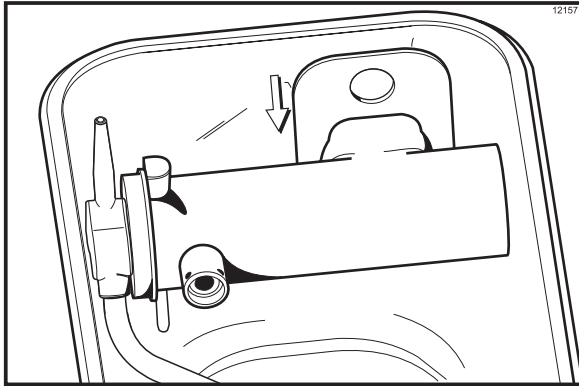

Figure 34

**Step 5**

Push one end of the vinyl sanitizing tube onto the air inlet tube for the pump. Be sure the free end is submerged in the sanitizing solution in the hopper.

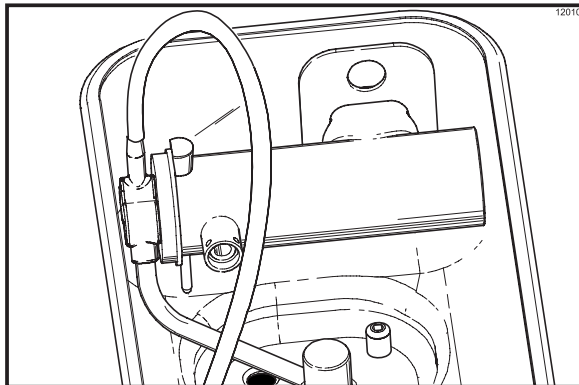

Figure 35

**Repeat steps 1 through 5** for the other side of the freezer on the Model 8754.

**Step 6**

Place the power switch in the ON position.

**Step 7**

Press the WASH key. This will cause the sanitizing solution in the freezing cylinder to agitate. Allow it to agitate for five minutes.

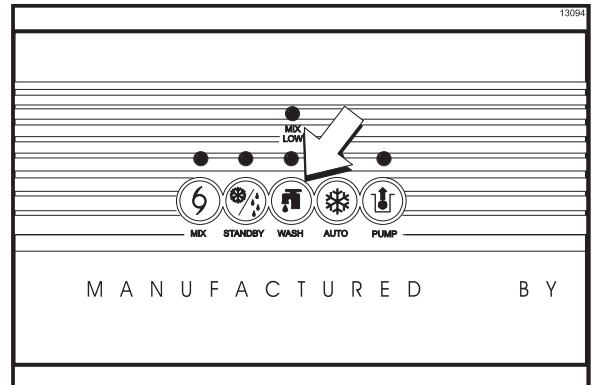

Figure 36

**Step 8**

With an empty pail beneath the door spout(s), raise the prime plug and press the PUMP key.

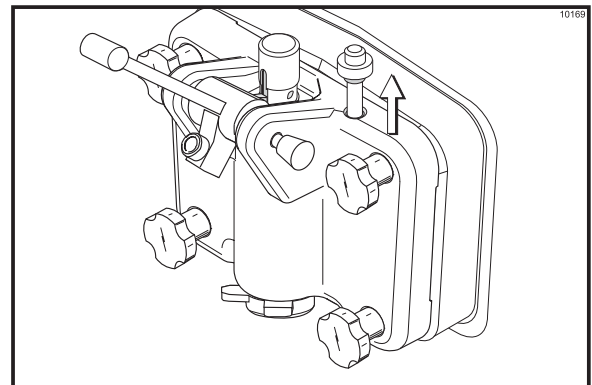

Figure 37

### Step 9

When a steady stream of sanitizing solution is flowing from the prime plug opening in the bottom of the freezer door, pull the draw handle down. Draw off all of the sanitizing solution. (**Note:** On the Model 8754, momentarily pull the center draw handle down to sanitize the center door spout.)

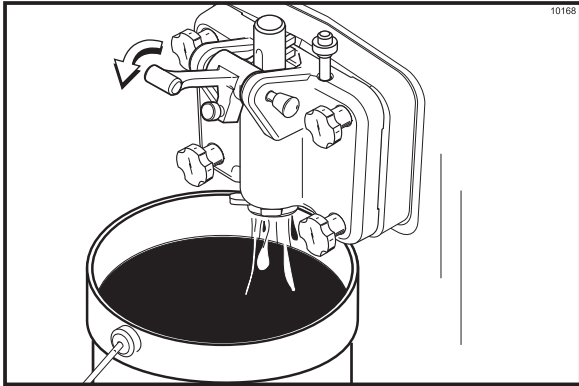

Figure 38

### Step 10

Once the sanitizer stops flowing from the door spout(s), raise the draw handle(s). Press the WASH and PUMP keys, cancelling the beater motor and pump operation.

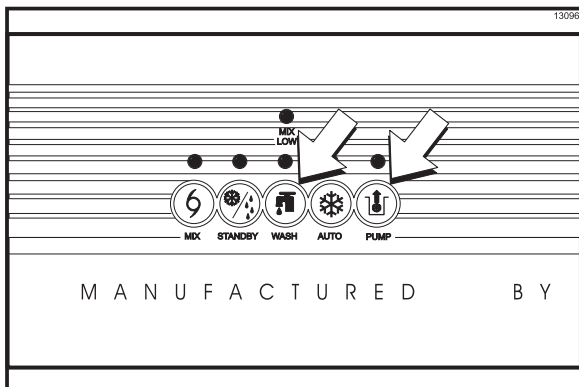

Figure 39

**Note: Be sure your hands are clean and sanitized before continuing these instructions.**

### Step 11

Remove the vinyl sanitizing tube from the air inlet tube on the air/mix pump.

### Step 12

Lubricate the mix feed tube o-rings located on the end of the tube with the small hole on the side. Stand the mix feed tube in the corner of the mix hopper. Place the locking clip in position in the outlet fitting of the pump.

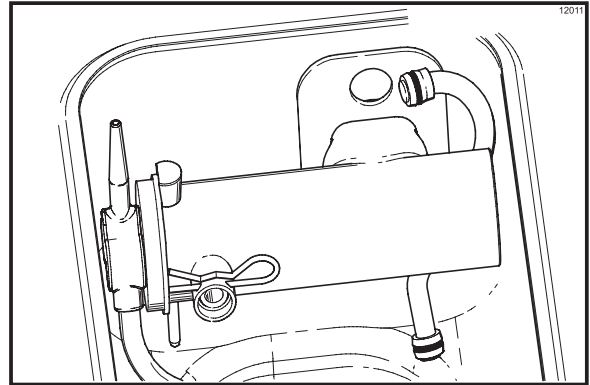

Figure 40

**Repeat Steps 6 through 12 for the other side of the freezer on the Model 8754.**

### Step 13

Assemble the hopper gasket around the top edge of the mix hopper.

## Priming

### Step 1

Place an empty pail beneath the door spout and lower the draw handle. Be sure the prime plug is still in the UP position. Pour two gallons (7.6 liters) of **fresh** mix into the hopper and allow it to flow into the freezing cylinder. This will force out any remaining sanitizing solution. When full strength mix is flowing from the door spout, raise the draw handle.

**Note: Use only fresh mix when priming the freezer.**

### Step 2

Once a **steady** stream of mix starts to flow from the prime plug opening in the bottom of the freezer door, push down the prime plug.

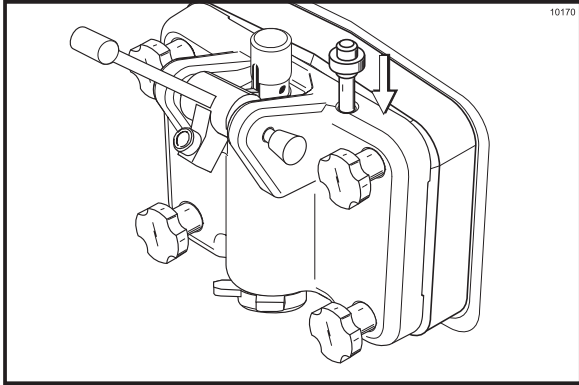

Figure 41

### Step 3

When the mix stops bubbling down into the freezing cylinder, insert the mix feed tube. Remove the locking clip from the outlet fitting of the mix pump. Insert the outlet end of the mix feed tube into the mix inlet hole in the mix hopper. Place the inlet end of the mix feed tube into the outlet fitting of the mix pump. Secure with locking clip.

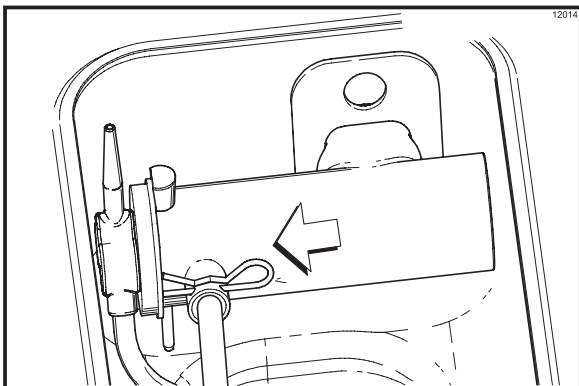

Figure 42

### Step 4

Press the AUTO key. When the unit cycles off, the product will be at serving viscosity.

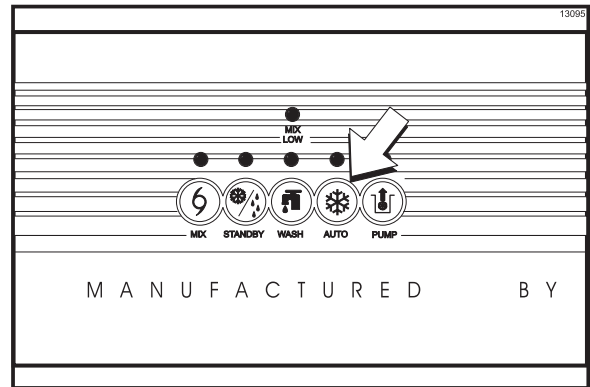

Figure 43

### Step 5

Fill the hopper with **fresh** mix. As the mix level comes in contact with the mix level sensing probe on the front wall of the hopper, the MIX LOW light will shut off.

**Note:** The MIX REF light will come on, indicating the mix refrigeration system is maintaining mix in the mix hopper.

### Step 6

Place the mix hopper cover in position.

**Repeat steps 1 through 6** for the other side of the freezer on the Model 8754.

## Closing Procedure

To disassemble your unit, the following items will be needed:

- Two cleaning pails
- Sanitized stainless steel rerun can with lid
- Necessary brushes (provided with freezer)
- Cleaner
- Single service towels

## Draining Product From the Freezing Cylinder

### Step 1

Press the AUTO key, cancelling compressor and beater motor operation.

Press the MIX REF key, cancelling the mix hopper refrigeration system.

### Step 2

Remove the hopper cover and gasket. Take these parts to the sink for cleaning.

### Step 3

With a sanitized pail beneath the door spout, press the WASH and PUMP keys. Lower the draw handle and drain the remaining product from the freezing cylinder and mix hopper.

### Step 4

When the flow of product stops, press the WASH and PUMP keys and close the draw valve.

### Step 5

If local health codes permit, empty the rerun into a sanitized stainless steel can. Cover the container and place it in the walk-in cooler.

### Step 6

Remove the assembled air/mix pump and take to the sink for further disassembly and cleaning.

**Repeat steps 1 through 6** for the other side of the freezer on the Model 8754.



**ALWAYS FOLLOW LOCAL HEALTH CODES.**

## Rinsing

### Step 1

Pour two gallons (7.6 liters) of **cool** clean water into the mix hopper. With the brushes provided, scrub the mix hopper, the mix inlet hole and the mix level sensing probe.

### Step 2

With a pail beneath the door spout, raise the prime plug and press the WASH key.

### Step 3

When a steady stream of rinse water is flowing from the prime plug opening in the bottom of the freezer door, lower the draw handle. Drain all the rinse water from the freezing cylinder. When the water stops flowing from the door spout, raise the draw handle and press the WASH key cancelling the WASH mode.

Repeat this procedure until the rinse water being drawn from the freezing cylinder is **clear**.

**Repeat steps 1 through 3** for the other side of the freezer on the Model 8754.

## Cleaning

### Step 1

Prepare two gallons (7.6 liters) of an approved 100 PPM cleaning solution (example: Kay-5®). **USE WARM WATER AND FOLLOW THE MANUFACTURER'S SPECIFICATIONS.**

### Step 2

Push down the prime plug. Pour the two gallons (7.6 liters) of cleaning solution into the mix hopper.

### Step 3

While the solution is flowing into the freezing cylinder, brush clean the mix hopper, mix level sensing probes and the mix inlet hole.

### Step 4

Press the WASH key. This will cause the cleaning solution in the freezing cylinder to be agitated.

### Step 5

Place an empty pail beneath the door spout and raise the prime plug.

### Step 6

When a steady stream of cleaning solution is flowing from the prime plug opening in the bottom of the freezer door, lower the draw handle. Draw off all of the solution.

### Step 7

Once the cleaning solution stops flowing from the door spout, raise the draw handle and press the WASH key, cancelling the WASH mode.

**Repeat steps 1 through 7** for the other side of the freezer on the Model 8754.

## Disassembly

### Step 1

**Be sure the power switch is in the OFF position.** Make sure no lights are lit on the control panel.

### Step 2

Remove the handscrews, freezer door(s), beater(s), beater shoes, scraper blades, and drive shaft(s) from the freezing cylinder(s). Take these parts to the sink for cleaning.

### Step 3

Remove the drive shaft(s) from the drive hub(s) in the rear wall of the mix hopper(s).

### Step 4

Remove the front drip tray and the splash shield.

## Brush Cleaning

### Step 1

Prepare a sink with an approved cleaning solution (example: Kay-5®). **USE WARM WATER AND FOLLOW THE MANUFACTURER'S SPECIFICATIONS.** If another approved cleaner is used, dilute according to label instructions.

**IMPORTANT:** Follow label directions, as too **STRONG** of a solution can cause parts damage, while too **MILD** of a solution will not provide adequate cleaning. Make sure all brushes provided with the freezer are available for brush cleaning.

### Step 2

Remove the seal(s) from the drive shaft(s).

### Step 3

From the freezer door(s) remove the gasket(s), front bearing(s), pivot pin, adjustable draw handle(s), draw valve(s), prime plug(s), and design cap(s). Remove all o-rings.

**Note:** To remove the o-rings, use a single service towel to grasp the o-ring. Apply pressure in an upward

direction until the o-ring pops out of its groove. With the other hand, push the top of the o-ring forward and it will roll out of the groove and can be easily removed. If there is more than one o-ring to be removed, always remove the rear o-ring first. This will allow the o-ring to slide over the forward rings without falling into the open grooves.

### Step 4

Remove the retaining pin(s), liquid valve body(ies), piston(s), mix inlet tube(s), spring(s) and poppet(s). Remove all o-rings, seal(s), and check bands.

### Step 5

Return to the freezer with a small amount of cleaning solution. With the black bristle brush, brush clean the rear shell bearing(s) at the back of the freezing cylinder(s). Brush clean the drive hub opening(s) in the rear wall of the mix hopper(s).

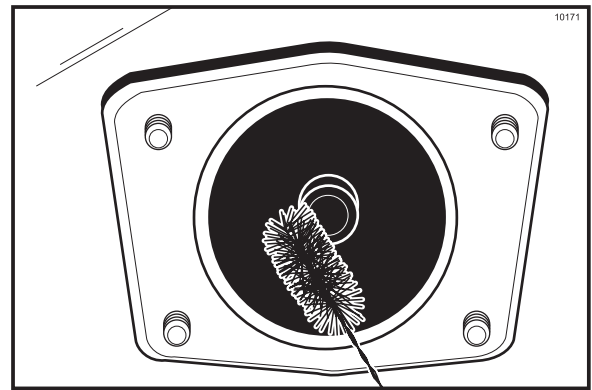

Figure 44

### Step 6

Remove the rear drip pan(s) from the side panel and take it to the sink for cleaning.

**Note:** If the drip pan is filled with an excessive amount of mix, refer to the Troubleshooting Guide.

### Step 7

Thoroughly brush clean all disassembled parts in the cleaning solution, making sure all lubricant and mix film is removed. Take particular care to brush clean the draw valve core(s) in the freezer door. Place all cleaned parts on a clean, dry surface to air dry overnight.

### Step 8

Wipe clean all exterior surfaces of the freezer.

# Section 7 Important: Operator Checklist

## During Cleaning and Sanitizing

Cleaning and sanitizing schedules are governed by your State or local regulatory agencies and must be followed accordingly. The following check points should be stressed during the cleaning and sanitizing operations.

**WE RECOMMEND DAILY CLEANING AND SANITIZING.**



## Troubleshooting Bacterial Count

- 1. Thoroughly clean and sanitize machine regularly, including complete disassembly and brush cleaning.
  - 2. Use all brushes supplied for thorough cleaning. The brushes are specially designed to reach all mix passageways.
  - 3. Use the white bristle brush to clean the mix inlet hole which extends from the mix hopper down to the rear of the freezing cylinder.
  - 4. Use the black bristle brush to thoroughly clean the rear shell bearing located at the rear of the freezing cylinder. Be sure to have a generous amount of cleaning solution on the brush.
  - 5. IF LOCAL HEALTH CODES PERMIT THE USE OF RERUN, make sure the mix rerun is stored in a sanitized, covered stainless steel container and used the following day. **DO NOT prime the machine with rerun.** When using rerun, skim off the foam and discard. Mix the rerun with fresh mix in a ratio of 50/50 during the days operation.
  - 6. On a designated day of the week, run the mix as low as feasible and discard it after closing. This will break the rerun cycle and reduce the possibility of high bacteria and coliform counts.
- 7. Properly prepare the cleaning and sanitizing solutions. Read and follow label directions carefully. Too strong of a solution may damage the parts and too weak of a solution will not do an adequate job of cleaning or sanitizing.
  - 8. The temperature of the mix in the mix hopper and walk-in cooler should be below 40°F. (4.4°C.).

## Regular Maintenance Checks

- 1. Replace scraper blades that are nicked or damaged. Before installing the beater assembly, be certain that scraper blades are properly attached to the helix.
- 2. Check the rear shell bearing for signs of wear (excessive mix leakage in rear drip pan) and be certain it is properly cleaned.
- 3. Using a screwdriver and cloth towel, keep the rear shell bearing and the female hex drive socket clean and free of lubricant and mix deposits.
- 4. Dispose of o-rings and seals if they are worn, torn, or fit too loosely, and replace with new ones.
- 5. Follow all lubricating procedures as outlined in "Assembly".
- 6. If your machine is air cooled, check the condensers for accumulation of dirt and lint. Dirty condensers will reduce the efficiency and capacity of the machine. Condensers should be cleaned **monthly** with a soft brush. **Never** use screwdrivers or other metal probes to clean between the fins.  
**Note:** For machines equipped with an air filter, it will be necessary to vacuum clean the filters on a monthly schedule.



**Caution: Always disconnect electrical power prior to cleaning the condenser.** Failure to follow this instruction may result in electrocution.

- 7. If your machine is equipped with an auxiliary refrigeration system, check the auxiliary condenser for accumulation of dirt and lint. Dirty condensers will reduce the refrigeration capacity of the mix hopper. Condensers must be cleaned **monthly** with a soft brush. **Never** use screwdrivers or other metal probes to clean between the fins.



**Caution:** Always disconnect electrical power prior to cleaning the condenser. Failure to follow this instruction may result in electrocution.

- 8. If your machine is water cooled, check the water lines for kinks or leaks. Kinks can occur when the machine is moved back and forth for cleaning or maintenance purposes. Deteriorated or cracked water lines should be replaced only by an authorized Taylor distributor.

## The Air/Mix Pump Checklist

- 1. Dispose of o-rings and check bands if they are worn, torn or fit too loosely. Replace them with new ones.
- 2. Follow lubricating procedures carefully. **Do not** lubricate check bands.
- 3. Handle plastic pump parts with care to avoid nicks and cracks.
- 4. Be sure the air/mix pump is properly attached to the drive hub, or severe and costly damage may occur.

## Winter Storage

If the place of business is to be closed during the winter months, it is important to protect the freezer by following certain precautions, particularly if the building is subject to freezing conditions.

Disconnect the freezer from the main power source to prevent possible electrical damage.

On water cooled freezers, disconnect the water supply. Relieve pressure on the spring in the water valve. Use air pressure on the outlet side to blow out any water remaining in the condenser, and then add a liberal amount of permanent type auto anti-freeze. **This is extremely important.** Failure to follow this procedure may cause severe and costly damage to the refrigeration system.

Your local Taylor Distributor can perform this winter storage service for you.

Wrap detachable parts of the freezer such as beater, blades, drive shaft, and freezer door, and place them in a protected dry place. Rubber trim parts and gaskets can be protected by wrapping them with moisture-proof paper. All parts should be thoroughly cleaned of dried mix or lubrication which attract mice and other vermin.



# Section 8

# Troubleshooting Guide

| PROBLEM   | PROBABLE CAUSE  | REMEDY  | PAGE REF. |
|---|---|---|-----------|
| 1. No product is being dispensed with draw valve open and the machine in the AUTO mode. | a. Freeze-up in mix inlet hole.                                   | a. Call service technician to adjust the mix hopper temperature.                  | ---       |
|   | b. Beater motor out on reset.                                     | b. Reset the freezer.   | 12        |
|   | c. The beater is rotating counterclockwise from the operator end. | c. Contact service technician to correct rotation to clockwise from operator end. | ---       |
|   | d. The circuit breaker is off or the fuse is blown.               | d. Turn the breaker on, or replace the fuse.                                      | ---       |
|   | e. There is inadequate mix in the mix hopper.                     | e. Fill the mix hopper with mix.  | 24        |
| 2. The product is too stiff.  | a. The viscosity needs adjustment.                                | a. Contact service technician.  | ---       |
| 3. The product is too soft.   | a. Viscosity needs adjustment.                                    | a. Contact service technician.  | ---       |
|   | b. Not enough air space around unit. (Air cooled units)           | b. Allow for adequate air flow across the condenser.                              | 1         |
|   | c. Worn scraper blades.   | c. Replace regularly.   | 33        |
|   | d. Dirty condenser (A/C)  | d. Clean monthly.   | 27        |
|   | e. Mix is out of date.  | e. Use only fresh mix.  | ---       |
|   | f. Loss of water. (W/C)   | f. Locate cause of water loss and correct.  | 28        |
| 4. The mix in the mix hopper is too cold.   | a. The temperature is out of adjustment.                          | a. Call service technician to adjust the mix hopper temperature.                  | ---       |

| <b>PROBLEM</b>  | <b>PROBABLE CAUSE</b>   | <b>REMEDY</b>  | <b>PAGE REF.</b> |
|---|---|--|------------------|
| 5. The mix in the mix hopper is too warm.             | a. The temperature is out of adjustment.                                      | a. Call service technician to adjust the mix hopper temperature.   | ---              |
|   | b. Missing or defective mix hopper gasket.                                    | b. Replace/install the gasket around the mix hopper.   | 23               |
|   | c. The mix hopper cover is not in position.                                   | c. Place the cover in position.  | 24               |
|   | d. The MIX REF light is not lit.  | d. Press the MIX REF key.  | 11               |
| 6. The drive shaft is stuck in the drive coupling.    | a. Rounded corners of drive shaft, coupling, or both.                         | a. Call service technician to correct cause, and to replace the necessary components. Do not lubricate the hex end of the drive shaft. | ---              |
|   | b. Mix and lubricant collected in the drive coupling.                         | b. Brush clean the rear shell bearing area regularly.  | 26               |
| 7. The freezing cylinder walls are scored.            | a. The beater assembly is bent.   | a. Call service technician to repair or replace the beater and to correct the cause of insufficient mix in the freezing cylinder.      | ---              |
|   | b. The front bearing is missing or worn on the freezer door.                  | b. Install or replace the front bearing.   | 15               |
| 8. Excessive mix leakage into the rear drip pan.      | a. Missing or worn drive shaft seal on drive shaft.                           | a. Install or replace regularly.   | 14 / 33          |
|   | b. The rear shell bearing is worn.  | b. Call service technician to replace rear shell bearing.  | ---              |
| 9. Excessive mix leakage from door spout.             | a. Missing or worn draw valve o-rings.  | a. Install or replace regularly.   | 16 / 33          |
|   | b. Inadequate lubrication of draw valve o-rings.                              | b. Lubricate properly.   | 16               |
|   | c. Wrong type of lubricant is being used (example: petroleum base lubricant). | c. Use the proper lubricant (example: Taylor Lube).  | 14               |
| 10. No freezer operation after pressing the AUTO key. | a. Unit is unplugged.   | a. Plug into wall receptacle.  | ---              |
|   | b. The circuit breaker is off or the fuse is blown.                           | b. Turn the breaker on, or replace the fuse.   | ---              |
|   | c. The beater motor is out on reset.  | c. Reset the freezer.  | 12               |

| <b>PROBLEM</b>  | <b>PROBABLE CAUSE</b>  | <b>REMEDY</b>  | <b>PAGE REF.</b>                           |
|---|--|--|--|
| 11. Product is not feeding into the freezing cylinder.  | <ul style="list-style-type: none"> <li>a. Inadequate level of mix in the mix hopper.</li> <li>b. The mix inlet hole is frozen up.</li> </ul>   | <ul style="list-style-type: none"> <li>a. Fill the mix hopper with mix.</li> <li>b. The mix hopper temperature needs adjustment. Call service technician.</li> </ul>   | <p>24</p> <p>---</p>                       |
| 12. The air/mix pump will not operate when the PUMP key is pressed.                                   | <ul style="list-style-type: none"> <li>a. The circuit breaker is off.</li> <li>b. The power cord is unplugged.</li> <li>c. The freezer is out on reset.</li> <li>d. The pump motor is out on reset.</li> </ul> | <ul style="list-style-type: none"> <li>a. Check the breaker.</li> <li>b. Plug in the power cord.</li> <li>c. Reset the freezer.</li> <li>d. Press the PUMP key to cancel pump operation. Press the reset button on the side of the pump motor reducer. Press the PUMP key to continue pump operation.</li> </ul> | <p>---</p> <p>---</p> <p>12</p> <p>---</p> |
| 13. The air/mix pump will not operate when the draw valve is opened and the unit is in the AUTO mode. | <ul style="list-style-type: none"> <li>a. The pump motor is out on reset.</li> <li>b. The relay is malfunctioning.</li> </ul>  | <ul style="list-style-type: none"> <li>a. Press the AUTO key to cancel the pump operation. Press the reset button on the side of the pump motor reducer. Press the AUTO key to continue automatic operation.</li> <li>b. Contact service technician.</li> </ul>  | <p>---</p> <p>---</p>                      |

| <b>PROBLEM</b>  | <b>PROBABLE CAUSE</b>                                     | <b>REMEDY</b>   | <b>PAGE REF.</b> |
|---|---|---|------------------|
| 14. The piston travels back and forth, but product is not being pumped. | a. Inspect the check bands.                               | a. Check bands must be installed correctly, fit tightly, and not have any holes or lubrication. Make sure check bands are not inside-out. | ---              |
|   | b. Inspect the o-rings.                                   | b. O-rings must not be worn, torn, or fit too loosely.  | 27               |
|   | c. Check the pump cylinder.                               | c. The piston and liquid valve body must be assembled correctly and fit snugly in the pump cylinder.                                      | 18               |
|   | d. Missing or defective spring or poppet.                 | d. Replace.   | 19               |
| 15. Excessive pump cylinder wear.                                       | a. Inadequate or incorrect lubrication of pump cylinder.  | a. Follow lubrication procedures carefully.   | 19               |
|   | b. Incorrect ball crank rotation.                         | b. Contact service technician.  | ---              |
| 16. Pitting occurring inside the pump cylinder.                         | a. Cleaner was left inside the pump cylinder.             | a. After brush cleaning the pump cylinder, allow it to air dry. Follow disassembly procedures carefully.                                  | 26               |
| 17. The ball crank of the motor reducer is broken.                      | a. Incorrect rotation of pump motor.                      | a. Contact service technician.  | ---              |
| 18. Too much pressure in the freezing cylinder.                         | a. Plugged relief hole in liquid valve body below poppet. | a. Clean.   | ---              |
| 19. Not enough pressure in the freezing cylinder.                       | a. Weak or bent spring in liquid valve body.              | a. Replace.   | ---              |
|   | b. Malfunctioning draw switch.                            | b. Contact service technician.  | ---              |
|   | c. Missing poppet.  | c. Install the poppet.  | 19               |

# Section 9

# Parts Replacement Schedule

| PART DESCRIPTION             | EVERY<br>3 MONTHS | EVERY<br>6 MONTHS                 | ANNUALLY |
|------------------------------|-------------------|-----------------------------------|----------|
| Drive Shaft Seal             | X                 |                                   |          |
| Scraper Blade                | X                 |                                   |          |
| Freezer Door Gasket          | X                 |                                   |          |
| Front Bearing                | X                 |                                   |          |
| Beater Shoes                 | X                 |                                   |          |
| Draw Valve O-Ring            | X                 |                                   |          |
| Pivot Pin O-Ring             | X                 |                                   |          |
| Prime Plug O-Ring            | X                 |                                   |          |
| Air Tube O-Ring              | X                 |                                   |          |
| Air Orifice O-Ring           | X                 |                                   |          |
| White Bristle Brush, 3" x 7" |                   | Inspect & Replace<br>if Necessary | Minimum  |
| White Bristle Brush, 1" x 2" |                   | Inspect & Replace<br>if Necessary | Minimum  |
| Black Bristle Brush, 1" x 2" |                   | Inspect & Replace<br>if Necessary | Minimum  |
| Double-Ended Brush           |                   | Inspect & Replace<br>if Necessary | Minimum  |

Refer to Parts List on the next page when ordering the above parts.

# Section 10

# Parts List

HP62 Refrigerant: 8751 - J6080596, 8754 - J6080465/Up

| DESCRIPTION            | PART NUMBER | 8751 QTY. | 8754 QTY. | WARR. CLASS | REMARKS                                     | PARTS UPDATE |
|------------------------|-------------|-----------|-----------|-------------|---|--------------|
| ADAPTOR A.-CASTER      | X18915      | 4         | 4         | 103         |   |              |
| BEARING-FRONT          | 050348      | 1         | 2         | 000         |   |              |
| SHOE-FRONT HELIX-REAR  | 050346      | 1         | 2         | 000         |   |              |
| SHOE-FRONT HELIX-FRONT | 050347      | 1         | 2         | 000         |   |              |
| BEARING-REAR SHELL     | 031324      | 1         | 2         | 000         |   |              |
| +GUIDE-DRIP SEAL       | 028992      | 1         | 2         | 000         |   |              |
| +NUT-BRASS BEARING     | 028991      | 1         | 2         | 000         |   |              |
| +WASHER-BEARING LOCK   | 012864      | 1         | 2         | 000         |   |              |
| BEATER ASSEMBLY        | X46231      | 1         | 2         | 103         |   |              |
| +BLADE-SCRAPER         | 046235      | 2         | 4         | 000         |   |              |
| +CLIP-SCRAPER BLADE    | 046236      | 2         | 4         | 103         |   |              |
| PIN-SCRAPER BLADE      | 014170      | 2         | 4         | 000         |   |              |
| BELT-AX35              | 022848      | 2         | 4         | 000         |   |              |
| BLOCK-TERMINAL-2 P     | 039422      | 1         | 2         | 103         | SINGLE PHASE                                |              |
| BLOCK-TERMINAL-3 P     | 039423      | 1         | 2         | 103         | THREE PHASE                                 |              |
| SCREW-TERMINAL BLOCK   | 039420      | 2         | 4         | 000         |   |              |
| BLOWER ASSEMBLY        | X53725-27   | 1         |           | 103         | 8751-J9036440/UP-3PH,<br>J9053627/UP-1PH    | 144          |
| MOTOR-BLOWER           | 053481-27   | 1         |           | 103         |   |              |
| BLOWER ASSEMBLY        | X53478-27   | 1         | 1         | 103         | 8751-PRIOR TO J9036440-3PH,<br>J9053627-1PH | 144          |
| BOOT-CAPACITOR         | 031314      | 1         | 1         | 000         |   |              |
| CAPACITOR-RUN          | 033047      | 1         | 1         | 103         |   |              |
| CLIP-SCREEN BLOWER     | 053730      | 4         | 4         | 103         |   |              |
| HOUSING-BLOWER         | 053727      | 1         | 1         | 103         |   |              |
| MOTOR-BLOWER           | 053480-27   | 1         | 1         | 103         |   |              |
| SCREEN-BLOWER          | 053729      | 1         | 1         | 103         |   |              |
| WHEEL-BLOWER           | 053726      | 1         | 1         | 103         |   |              |
| BOARD-LOGIC            | X42002SER1  | 1         | 2         | 212         |   |              |
| BOARD-POWER            | X32326-SER  | 1         | 2         | 212         |   |              |
| FUSE-SLO BLO           | 051272      | 1         | 2         | 103         |   |              |

+ Available Separately

| DESCRIPTION              | PART NUMBER | 8751 QTY. | 8754 QTY. | WARR. CLASS | REMARKS  | PARTS UPDATE   |
|--------------------------|-------------|-----------|-----------|-------------|--|----------------|
| BRUSH-BLACK (1" X 2")    | 013071      | 1         | 1         | 000         |  |                |
| BRUSH-DOUBLE END         | 013072      | 1         | 1         | 000         |  |                |
| BRUSH-WHITE (1" X 2")    | 013073      | 1         | 1         | 000         |  |                |
| BRUSH-WHITE (3" X 7")    | 023316      | 1         | 1         | 000         |  |                |
| CABLE-RIBBON             | 032445      | 1         | 2         | 103         |  |                |
| CAP-DESIGN               | 014218      | 1         | 3         | 000         |  |                |
| CAPACITOR-START          | 037251-     | 1         | 2         | 103         | PUMP   |                |
| CASTER-SWIVEL            | 018794      | 4         | 4         | 103         |  |                |
| COMPRESSOR- COPELAND     | 052397-33   | 1         |           | 512         | 8751-J9036440/UP-3PH   | 144            |
| COMPRESSOR- COPELAND     | 052397-     | 1         | 2         | 512         | 8754-J9036611/UP,<br>8751-J9053627/UP-1PH  | 141/142<br>144 |
| CAPACITOR-RUN            | 029439      | 1         | 2         | 103         | 230-60-1   |                |
| CAPACITOR-START          | 031304      | 1         | 2         | 103         | 230-60-1   |                |
| RELAY-START              | 052401-27   | 1         | 2         | 103         | 230-60-1   |                |
| COMPRESSOR - BRISTOL     | 048259-     | 1         | 2         | 512         | 8754-PRIOR TO J9036611,<br>8751-PRIOR TO J9036440-3ph 60hz,<br>8751-PRIOR TO J9053627-1ph 60hz | 141<br>144     |
| CAPACITOR-RUN            | 012906      | 1         | 2         | 103         | 230-60-1   |                |
| CAPACITOR-START          | 031790      | 1         | 2         | 103         | 230-60-1   |                |
| RELAY-START              | 038145      | 1         | 2         | 103         | 230-60-1   |                |
| COMPRESSOR-AUXILIARY     | 047701-27   | 1         | 1         | 512         |  |                |
| CAPACITOR-START          | 047703      | 1         | 1         | 103         |  |                |
| RELAY-START              | 047702-27   | 1         | 1         | 103         |  |                |
| COVER-TERMINAL           | 047739      | 1         | 1         | 103         |  |                |
| CONDENSER-AUXILIARY      | 027155      | 1         | 1         | 103         |  |                |
| CONDENSER-MAIN           | 048233      | 1         | 2         | 103         |  |                |
| COUPLING-DRIVE           | 012721      | 1         | 2         | 103         |  |                |
| COVER A.-MIX HOPPER      | X38458-SER  | 1         | 2         | 103         |  |                |
| +GASKET-MIX HOPPER       | 038375      | 1         |           | 000         |  |                |
| +GASKET-MIX HOPPER       | 038474      |           | 1         | 000         |  |                |
| KNOB-MIX HOPPER          | 025429      | 1         | 2         | 103         |  |                |
| DECAL-CLEAN AND SANITIZE | 042170      | 1         | 1         | 000         |  |                |

+ Available Separately

| DESCRIPTION                       | PART NUMBER | 8751 QTY. | 8754 QTY. | WARR. CLASS | REMARKS                             | PARTS UPDATE |
|-----------------------------------|-------------|-----------|-----------|-------------|-------------------------------------|--------------|
| DECAL-DECORATIVE                  | 033231      | 1         |           | 000         |                                     |              |
| DECAL-DECORATIVE                  | 033232      |           | 1         | 000         |                                     |              |
| DECAL-POWER SWITCH - ON/OFF (OLD) | 032484      |           | 1         | 000         | PRIOR TO J8080000 (NEW - SEE LABEL) | 132          |
| DECAL-POWER SWITCH - ON/OFF       | 032484      | 1         |           | 000         |                                     |              |
| DECAL-TROUBLESHOOTING             | 038374      | 1         | 1         | 000         |                                     |              |
| DEFLECTOR-BLOWER EXHAUST          | 046586      | 1         | 1         | 103         |                                     |              |
| DIAGRAM-WIRING (NEW)              | 052613-     | 1         |           | 000         | W/COPELAND                          | 136/144      |
| DIAGRAM-WIRING (OLD)              | 050318-     | 1         |           | 000         | PRIOR TO COPELAND                   | 136/144      |
| DIAGRAM-WIRING                    | 046585-     |           | 1         | 000         |                                     |              |
| DOOR A.-FREEZER                   | X51531-10   | 1         |           | 103         |                                     |              |
| +BEARING-FRONT                    | 050216      | 1         |           | 000         |                                     |              |
| +CAP-DESIGN                       | 014218      | 1         |           | 000         |                                     |              |
| +GASKET-DOOR                      | 048926      | 1         |           | 000         |                                     |              |
| DOOR A.-FREEZER                   | X51532-12   |           | 1         | 103         |                                     |              |
| +BEARING-FRONT                    | 050216      |           | 2         | 000         |                                     |              |
| +CAP-DESIGN                       | 014218      |           | 3         | 000         |                                     |              |
| DECAL-DOOR                        | 021521      |           | 1         | 000         |                                     |              |
| +GASKET-DOOR                      | 048926      |           | 2         | 000         |                                     |              |
| DRYER-CAPILLARY                   | 047699      | 1         | 1         | 000         | AUXILIARY                           |              |
| DRYER-FILTER                      | 048901      | 1         | 2         | 000         |                                     |              |
| GASKET-HOPPER                     | 038375      | 1         | 2         | 000         |                                     |              |
| GEAR-REDUCER                      | 021286-SER  | 1         | 2         | 212         |                                     |              |
| GUIDE A.-DRIP PAN                 | X28863      | 1         |           | 103         |                                     |              |
| GUIDE A.-DRIP PAN                 | X28699      |           | 1         | 103         |                                     |              |
| GUIDE A.-DRIP PAN-PUMP            | X48433      | 1         |           | 103         | HOPPER PUMP                         |              |
| HANDLE A.-ADJUSTABLE DRAW         | X26996      | 1         |           | 103         |                                     |              |
| HANDLE-DRAW                       | 028804      | 1         |           | 103         |                                     |              |
| SCREW-ADJUSTABLE                  | 026592      | 1         |           | 000         | PLASTIC                             |              |
| O-RING                            | 015872      | 1         |           | 000         |                                     |              |
| HANDLE A.-ADJUSTABLE DRAW         | X33687      |           | 3         | 103         | J7090000/UP (REPLACES X26996)       | 121          |
| HANDLE-DRAW                       | 028804      |           | 3         | 103         |                                     |              |
| SCREW-ADJUSTABLE                  | 033662      |           | 3         | 103         | STAINLESS                           | 121          |
| O-RING                            | 015872      |           | 3         | 000         |                                     |              |

+ Available Separately



| DESCRIPTION                         | PART NUMBER | 8751 QTY. | 8754 QTY. | WARR. CLASS | REMARKS | PARTS UPDATE |
|-------------------------------------|-------------|-----------|-----------|-------------|---------|--------------|
| HOOD                                | X41996      | 1         |           | 103         |         |              |
| HOOD                                | 013667      |           | 1         | 103         |         |              |
| KIT A.-TUNE-UP                      | X49463-9    | 1         |           | 000         |         |              |
| BAND-CHECK (LIQUID VALVE BODY)      | 020050      | 2         |           | 000         |         |              |
| BAND-CHECK (LIQUID VALVE BODY)      | 033215      | 1         |           | 000         |         |              |
| BEARING-FRONT (FREEZER DOOR)        | 050348      | 1         |           | 000         |         |              |
| SHOE-FRONT HELIX-REAR               | 050346      | 1         |           | 000         |         |              |
| SHOE-FRONT HELIX-FRONT              | 050347      | 1         |           | 000         |         |              |
| CAP-DESIGN (FREEZER DOOR)           | 014218      | 1         |           | 000         |         |              |
| GASKET-DOOR                         | 048926      | 1         |           | 000         |         |              |
| O-RING (PRIME PLUG)                 | 016137      | 3         |           | 000         |         |              |
| O-RING (DRAW VALVE)                 | 014402      | 2         |           | 000         |         |              |
| O-RING (PUMP DRIVE SHAFT)           | 008904      | 1         |           | 000         |         |              |
| O-RING (LIQUID VALVE BODY)          | 018664      | 1         |           | 000         |         |              |
| O-RING (LIQUID VALVE BODY & PISTON) | 020051      | 3         |           | 000         |         |              |
| O-RING (MIX INLET TUBE)             | 015835      | 1         |           | 000         |         |              |
| O-RING (MIX FEED TUBE)              | 016132      | 2         |           | 000         |         |              |
| O-RING (PIVOT PIN)                  | 016272      | 1         |           | 000         |         |              |
| POPPET-RUBBER                       | 022473      | 1         |           | 000         |         |              |
| SEAL (AIR INLET FITTING)            | 045327      | 1         |           | 000         |         |              |
| SEAL (BEATER DRIVE SHAFT)           | 032560      | 1         |           | 000         |         |              |
| O-RING (PUMP DRIVE SHAFT)           | 048632      | 2         |           | 000         |         |              |
| SPRING                              | 022456      | 1         |           | 000         |         |              |
| KIT A.-TUNE-UP                      | X49463-19   |           | 1         | 000         |         |              |
| BAND-CHECK (LIQUID VALVE BODY)      | 020050      |           | 4         | 000         |         |              |
| BAND-CHECK (LIQUID VALVE BODY)      | 033215      |           | 2         | 000         |         |              |
| BEARING-FRONT (FREEZER DOOR)        | 050348      |           | 2         | 000         |         |              |
| CAP-DESIGN (FREEZER DOOR)           | 014218      |           | 3         | 000         |         |              |
| GASKET-DOOR                         | 048926      |           | 2         | 000         |         |              |
| O-RING (PRIME PLUG)                 | 016137      |           | 4         | 000         |         |              |
| O-RING (DRAW VALVE)                 | 014402      |           | 7         | 000         |         |              |
| O-RING (DRIVE CRANK)                | 008904      |           | 2         | 000         |         |              |
| O-RING (LIQUID VALVE BODY)          | 018664      |           | 2         | 000         |         |              |

+ Available Separately

| DESCRIPTION                             | PART NUMBER | 8751 QTY. | 8754 QTY. | WARR. CLASS | REMARKS                   | PARTS UPDATE |
|---|-------------|-----------|-----------|-------------|---------------------------|--------------|
| O-RING (LIQUID VALVE BODY & PISTON)     | 020051      |           | 6         | 000         |                           |              |
| O-RING (MIX INLET TUBE)                 | 015835      |           | 2         | 000         |                           |              |
| O-RING (MIX FEED TUBE)                  | 016132      |           | 4         | 000         |                           |              |
| O-RING (PIVOT PIN)                      | 016272      |           | 1         | 000         |                           |              |
| O-RING (PUMP DRIVE SHAFT)               | 048632      |           | 4         | 000         |                           |              |
| POPPET - RUBBER                         | 022473      |           | 2         | 000         |                           |              |
| SEAL - DRAW VALVE                       | 034698      |           | 1         | 000         |                           |              |
| SEAL (AIR INLET FITTING)                | 045327      |           | 2         | 000         |                           |              |
| SEAL (BEATER DRIVE SHAFT)               | 032560      |           | 2         | 000         |                           |              |
| SHOE - FRONT HELIX - REAR               | 050346      |           | 2         | 000         |                           |              |
| SHOE - FRONT HELIX - FRONT              | 050347      |           | 2         | 000         |                           |              |
| SPRING                                  | 022456      |           | 2         | 000         |                           |              |
| TOOL - O-RING REMOVAL                   | 048260-WHT  |           | 1         | 000         |                           |              |
| LABEL - DOOR - WARN - MOVE PARTS        | 032749      | 1         | 1         | 000         |                           |              |
| LABEL - SWITCH - POWER - OFF/ON SYMBOLS | 032632      |           | 1         | 000         | ON POSITION - RIGHT SIDE  | 132/142      |
| LABEL - WARN - COVER                    | 051433      | 5         | 6         | 000         |                           |              |
| LOUVER - SIDE                           | 017471      |           | 1         | 103         | RIGHT                     |              |
| LOUVER - SIDE                           | 028288      |           | 1         | 103         | LEFT                      |              |
| LOUVER - SIDE                           | 017471      | 2         | 2         | 103         |                           |              |
| LUBRICANT - TAYLOR 4 OZ.                | 047518      | 1         | 1         | 000         |                           |              |
| MAN-OPER                                | 028754-M    | 1         | 1         | 000         |                           |              |
| MOTOR-BEATER                            | 021522-     | 1         | 2         | 212         |                           |              |
| CAPACITOR-RUN (230-60-1)                | 027087      | 1         | 2         | 103         | MAGNETEK/CENTURY 230-30-1 |              |
| CAPACITOR-RUN (230-60-1)                | 036084      | 1         | 2         | 103         | LEESON 230-30-1           |              |
| CAPACITOR-START (230-60-1)              | 028315      | 1         | 2         | 103         | MAGNETEK/CENTURY 230-30-1 |              |
| CAPACITOR-START (230-60-1)              | 045862      | 1         | 2         | 103         | LEESON 230-30-1           |              |
| MOTOR-FAN (w/BLADE)                     | 027309-     | 1         | 1         | 103         | SHR                       |              |
| +BLADE-FAN                              | 033499      | 1         | 1         | 103         | SHR                       |              |
| MOTOR-REDUCER                           | 036955-34   | 1         | 2         | 103         |                           |              |
| +OVERLOAD                               | 044464      | 1         | 2         | 103         |                           |              |
| NUT-JAM-5/16-24                         | 029639-BLK  |           | 3         | 000         | J7090000/UP               | 121          |
| NUT-STUD (HANDSCREW)                    | 021508      | 4         |           | 103         | HANDSCREW                 |              |
| NUT-STUD (LONG)                         | 034382      |           | 2         | 103         | LONG                      |              |

+ Available Separately

| DESCRIPTION                       | PART NUMBER | 8751 QTY. | 8754 QTY. | WARR. CLASS | REMARKS            | PARTS UPDATE |
|-----------------------------------|-------------|-----------|-----------|-------------|--------------------|--------------|
| NUT-STUD (SHORT)                  | 034383      |           | 2         | 103         | SHORT              |              |
| ORIFICE-AIR                       | 022465-100  | 1         | 2         | 103         |                    |              |
| O-RING                            | 016137      | 1         | 2         | 000         |                    |              |
| PAIL                              | 013163      | 1         | 1         | 000         | 10 QT. / 9.5 LITER |              |
| PAN-DRIP                          | 048435      | 1         |           | 103         | HOPPER PUMP        |              |
| PAN A.-DRIP                       | X38198      |           | 1         | 103         | HOPPER PUMP        |              |
| PAN-DRIP - 11-5/8" LONG           | 027503      | 1         |           | 103         |                    |              |
| PAN-DRIP 17-1/4" LONG             | 027504      |           | 1         | 103         |                    |              |
| PANEL-REAR                        | 048203      | 1         |           | 103         |                    |              |
| PANEL-REAR                        | 017563      |           | 1         | 103         |                    |              |
| PANEL-SERVICE                     | 047170      | 1         |           | 103         |                    |              |
| PANEL-SERVICE                     | 046584      |           | 1         | 103         |                    |              |
| PANEL-UPPER RIGHT SIDE            | 028823      | 1         | 1         | 103         |                    |              |
| PANEL-LOWER RIGHT SIDE            | X24424-SER  | 1         |           | 103         |                    |              |
| PANEL A.-LOWER SIDE-LOUVERED-LEFT | X39075-SER  | 1         |           | 103         |                    |              |
| PANEL-UPPER SIDE                  | 024426      | 1         |           | 103         |                    |              |
| PANEL-UPPER SIDE-LEFT             | 028822      |           | 1         | 103         |                    |              |
| PANEL A.-LOWER SIDE-LEFT          | X46447-SER  | 1         |           | 103         |                    |              |
| PANEL A.-LOWER SIDE-RIGHT         | X46448-SER  |           | 1         | 103         |                    |              |
| PANEL A.-FRONT                    | X33237      | 1         |           | 103         |                    |              |
| PANEL A.-FRONT                    | X32956      |           | 1         | 103         |                    |              |
| PIN A.-PIVOT                      | X22820      | 1         |           | 103         |                    |              |
| +O-RING                           | 016272      | 1         |           | 000         |                    |              |
| PIN A.-PIVOT                      | X20683      |           | 1         | 103         |                    |              |
| +O-RING                           | 016272      |           | 1         | 000         |                    |              |
| PLATE-DECORATIVE                  | 033239      | 1         |           | 103         |                    |              |
| PLATE-DECORATIVE                  | 032961      |           | 1         | 103         |                    |              |
| PLUG-DRIP TRAY HOLE               | 029595      |           | 1         | 000         |                    |              |
| PLUG-PRIME                        | 028805      | 1         | 2         | 103         |                    |              |
| +O-RING                           | 016137      | 2         | 4         | 000         |                    |              |
| PROBE A.-MIX                      | X30922      | 1         | 2         | 103         |                    |              |
| +DISC                             | 030965      | 1         | 2         | 103         |                    |              |
| +SPACER                           | 030966      | 1         | 2         | 103         |                    |              |

+ Available Separately

| DESCRIPTION                         | PART NUMBER | 8751 QTY. | 8754 QTY. | WARR. CLASS | REMARKS       | PARTS UPDATE |
|-------------------------------------|-------------|-----------|-----------|-------------|---------------|--------------|
| PROBE A.-THERMISTOR - HOPPER        | X50717      | 1         | 1         | 103         |               |              |
| PROBE A.-THERMISTOR - BARREL        | X31602      | 1         | 2         | 103         |               |              |
| PULLEY (BEATER MOTOR)               | 016403      | 1         | 2         | 103         | BEATER MOTOR  |              |
| PULLEY (GEAR)                       | 027822      | 1         | 2         | 103         | GEAR          |              |
| PUMP A.-COAXIAL AIR/MIX             | X45316-B    | 1         | 2         | 103         |               |              |
| BAND-CHECK (LIQUID VALVE BODY)      | 020050      | 2         | 4         | 000         |               |              |
| BAND-CHECK (LIQUID VALVE BODY)      | 033215      | 1         | 2         | 000         |               |              |
| BODY A.-LIQUID VALVE                | X46860-B    | 1         | 2         | 103         |               |              |
| +CLIP-LOCKING                       | 044731      | 1         | 2         | 103         |               |              |
| +CLIP-PUMP                          | 044641      | 1         | 2         | 103         |               |              |
| CYLINDER A.-PUMP                    | X44755      | 1         | 2         | 103         |               |              |
| O-RING (LIQUID VALVE BODY)          | 018664      | 1         | 2         | 000         |               |              |
| O-RING (LIQUID VALVE BODY & PISTON) | 020051      | 3         | 6         | 000         |               |              |
| PIN A.-PUMP                         | X36950      | 1         | 2         | 103         |               |              |
| PISTON                              | 045319-B    | 1         | 2         | 103         |               |              |
| POPPET-RUBBER                       | 022473      | 1         | 2         | 000         |               |              |
| SPRING                              | 022456      | 1         | 2         | 000         |               |              |
| TUBE A.-MIX INLET                   | X45318      | 1         | 2         | 103         |               |              |
| O-RING                              | 015835      | 1         | 2         | 000         |               |              |
| SEAL                                | 045327      | 1         | 2         | 000         |               |              |
| RELAY-COMPRESSOR                    | 012725-     | 1         | 2         | 103         |               |              |
| RELAY-SPDT-30A-240V (A/C)           | 032607-     | 1         | 1         | 103         | FOR BLOWER    |              |
| RELAY                               | 039725-     | 1         | 2         | 103         | MOTOR REDUCER |              |
| SANITIZER-KAY-5                     | 041082      | 1         | 1         | 000         |               |              |
| SHAFT A.-DRIVE                      | X39084      | 1         | 2         | 103         |               |              |
| O-RING (DRIVE CRANK)                | 008904      | 1         | 2         | 000         |               |              |
| O-RING (DRIVE CRANK)                | 048632      | 2         | 4         | 000         |               |              |
| SHAFT-BEATER DRIVE                  | 032564      | 1         | 2         | 103         |               |              |
| +SEAL-DRIVE SHAFT                   | 032560      | 1         | 2         | 000         |               |              |
| SHELL A.-INSULATED                  | X50332      | 1         |           | 512         |               |              |
| SHELL A.-INSULATED                  | X50376      |           | 1         | 512         |               |              |
| +STUD-NOSE CONE                     | 022822      | 4         | 4         | 103         |               |              |
| SHIELD-SPLASH                       | 022763      | 1         |           | 103         |               |              |

+ Available Separately

| DESCRIPTION                          | PART NUMBER | 8751 QTY. | 8754 QTY. | WARR. CLASS | REMARKS  | PARTS UPDATE |
|--------------------------------------|-------------|-----------|-----------|-------------|----------|--------------|
| SHIELD- SPLASH                       | 022766      |           | 1         | 103         |          |              |
| SLEEVE A.- MIX PUMP                  | X45012      | 1         | 2         | 103         |          |              |
| +NUT- PUMP SLEEVE                    | 036933      | 1         | 2         | 103         |          |              |
| STARTER- BEATER LINE                 | 041950-     | 1         | 2         | 103         |          |              |
| OVERLOAD- THERMAL                    | 047150-     | 1         | 2         | 103         |          |              |
| SWITCH- PRESSURE 405 PSI (A/C) - NEW | 052663      | 1         |           | 103         | COPELAND | 136/142      |
| SWITCH- PRESSURE 440 PSI (A/C)       | 048230      | 1         | 2         | 103         | BRISTOL  | 136/142      |
| SWITCH- TOGGLE (POWER SWITCH)        | 024295      | 1         |           | 103         |          |              |
| SWITCH- TOGGLE (POWER SWITCH)        | 037394      |           | 1         | 103         |          |              |
| SWITCH A.- DRAW                      | X33322-SER  | 1         |           | 103         |          |              |
| ARM A.- SWITCH                       | X33326      | 1         |           | 103         |          |              |
| BRACKET A.- SWITCH                   | X43722      | 1         |           | 103         |          |              |
| E- RING                              | 049178      | 1         |           | 000         |          |              |
| PIN- PIVOT                           | 015478      | 1         |           | 103         |          |              |
| SPRING- LEFT RETURN                  | 041660      | 1         |           | 103         |          |              |
| SPRING- RIGHT RETURN                 | 041661      | 1         |           | 103         |          |              |
| SWITCH- MICRO                        | 028889      | 1         |           | 103         |          |              |
| SWITCH A.- DRAW                      | X38547      |           | 1         | 103         |          |              |
| ARM- SWITCH- LEFT                    | 038649      |           | 1         | 103         |          |              |
| ARM- SWITCH- RIGHT                   | 038650      |           | 1         | 103         |          |              |
| BRACKET A.- SWITCH                   | X38252      |           | 1         | 103         |          |              |
| E- RING                              | 032190      |           | 4         | 000         |          |              |
| PIN- PIVOT                           | 038484      |           | 1         | 103         |          |              |
| ROD- SPRING RETAINER                 | 038254      |           | 1         | 103         |          |              |
| SPRING- EXTENSION                    | 038922      |           | 2         | 103         |          |              |
| SPRING- LEFT RETURN                  | 038923      |           | 1         | 103         |          |              |
| SPRING- RIGHT RETURN                 | 038924      |           | 1         | 103         |          |              |
| SWITCH A.- DRAW                      | X39269      |           | 1         | 103         |          |              |
| BRACKET- SWITCH                      | 039264      |           | 1         | 103         |          |              |
| SWITCH- MICR+A3210                   | 039252      |           | 2         | 103         |          |              |
| TRAY- FRONT DRIP                     | 013690      | 1         |           | 103         |          |              |
| TRAY- FRONT DRIP                     | 014533      |           | 1         | 103         |          |              |
| TRIM- LEFT REAR CORNER               | 020882      | 1         |           | 103         |          |              |

+ Available Separately

| DESCRIPTION               | PART NUMBER | 8751 QTY. | 8754 QTY. | WARR. CLASS | REMARKS                    | PARTS UPDATE |
|---------------------------|-------------|-----------|-----------|-------------|----------------------------|--------------|
| TRIM-LEFT REAR CORNER     | 013761      |           | 1         | 103         |                            |              |
| TRIM-RIGHT REAR CORNER    | 020883      | 1         |           | 103         |                            |              |
| TRIM-RIGHT REAR CORNER    | 013663      |           | 1         | 103         |                            |              |
| TUBE A.-MIX FEED          | X44666      | 1         |           | 103         |                            |              |
| +O-RING                   | 016132      | 2         |           | 000         |                            |              |
| TUBE A.-FEED (LEFT)       | X44662      |           | 1         | 103         |                            |              |
| TUBE A.-FEED (RIGHT)      | X44664      |           | 1         | 103         |                            |              |
| O-RING-FEED TUBE          | 016132      |           | 4         | 000         |                            |              |
| VALVE-ACCESS              | 047016      | 1         | 2         | 103         |                            |              |
| VALVE-ACCESS              | 044455      | 1         | 2         | 103         |                            |              |
| VALVE-ACCESS              | 043232      | 1         |           | 103         |                            |              |
| VALVE-ACCESS              | 044404      | 1         | 1         | 103         |                            |              |
| VALVE-ACCESS              | 029406      | 1         | 1         | 103         |                            |              |
| VALVE-AUTOMATIC EXPANSION | 046365      | 1         | 2         | 103         |                            |              |
| +BOOT-EXPANSION VALVE     | 050900      | 1         | 2         | 000         |                            |              |
| VALVE-E.P.R.              | 022665      | 1         | 1         | 103         |                            |              |
| VALVE A.-DRAW             | X18303      | 1         | 3         | 103         | J7060000 (REPLACES X45380) | 118          |
| +O-RING                   | 014402      | 2         | 6         | 000         |                            |              |
| VIDEO-TRAINING            | 047247-     | 1         | 1         | 000         |                            |              |

+ Available Separately

| DESCRIPTION                      | PART NUMBER | 8751 QTY. | 8754 QTY. | WARR. CLASS | REMARKS   | PARTS UPDATE |
|----------------------------------|-------------|-----------|-----------|-------------|---|--------------|
| <b>OPTIONAL FEATURES</b>         |             |           |           |             |   |              |
| <b>WATER COOLED</b>              |             |           |           |             |   |              |
| BLOWER                           | 012796-     | 1         | 1         | 103         |   |              |
| +GUARD-BLOWER                    | 022505      | 1         | 1         | 103         |   |              |
| CONDENSER                        | 048287      | 1         | 2         | 103         |   |              |
| PANEL A.- LOWER SIDE (R & L)     | X24424-SER  | 2         | 2         | 103         |   |              |
| SWITCH- PRESSURE                 | 048231      | 1         | 2         | 103         |   |              |
| VALVE- WATER                     | 046686      | 1         | 2         | 103         |   |              |
|                                  |             |           |           |             |   |              |
| <b>50 CYCLE</b>                  |             |           |           |             |   |              |
| BLOCK- TERMINAL (230-50-1)       | 039421      | 1         | 2         | 103         |   |              |
| BLOCK- TERMINAL (220/440-50-3)   | 039424      | 1         | 2         | 103         |   |              |
| CAPACITOR-RUN (BEATER MOTOR)     | 023606      | 1         | 2         | 103         | CENTURY/MAGNETEK                                  |              |
| CAPACITOR-RUN (BEATER MOTOR)     | 023739      | 1         | 2         | 103         | LEESON  |              |
| CAPACITOR-START (BEATER MOTOR)   | 028315      | 1         | 2         | 103         | CENTURY/MAGNETEK                                  |              |
| CAPACITOR-START (BEATER MOTOR)   | 026659      | 1         | 2         | 103         | LEESON  |              |
| COMPRESSOR-COPELAND              | 052397-     | 1         | 2         | 512         | 8751-J9053634/UP                                  | 144          |
|                                  |             |           |           |             | 8754-J9036611/UP                                  | 141          |
| CAPACITOR-RUN- 45UF/370V         | 052400      | 1         | 2         | 103         | 230-50-1  |              |
| CAPACITOR-START-145-175UF/250V   | 052399      | 1         | 2         | 103         | 230-50-1  |              |
| RELAY-START COMPRESSOR           | 052401-27   | 1         | 2         | 103         | 230-50-1  |              |
| COMPRESSOR (MAIN - HP62) BRISTOL | 048259-     | 1         | 2         | 512         | 8751-PRIOR TO J9053634,<br>8754-PRIOR TO J9036611 | 144<br>141   |
| CAPACITOR-RUN                    | 023739      | 1         | 2         | 103         | 230-50-1  |              |
| CAPACITOR-START                  | 031790      | 1         | 2         | 103         | 230-50-1  |              |
| RELAY-START                      | 038146      | 1         | 2         | 103         | 230-50-1  |              |
| PULLEY (BEATER MOTOR)            | 011545      | 1         | 2         | 103         |   |              |

+ Available Separately

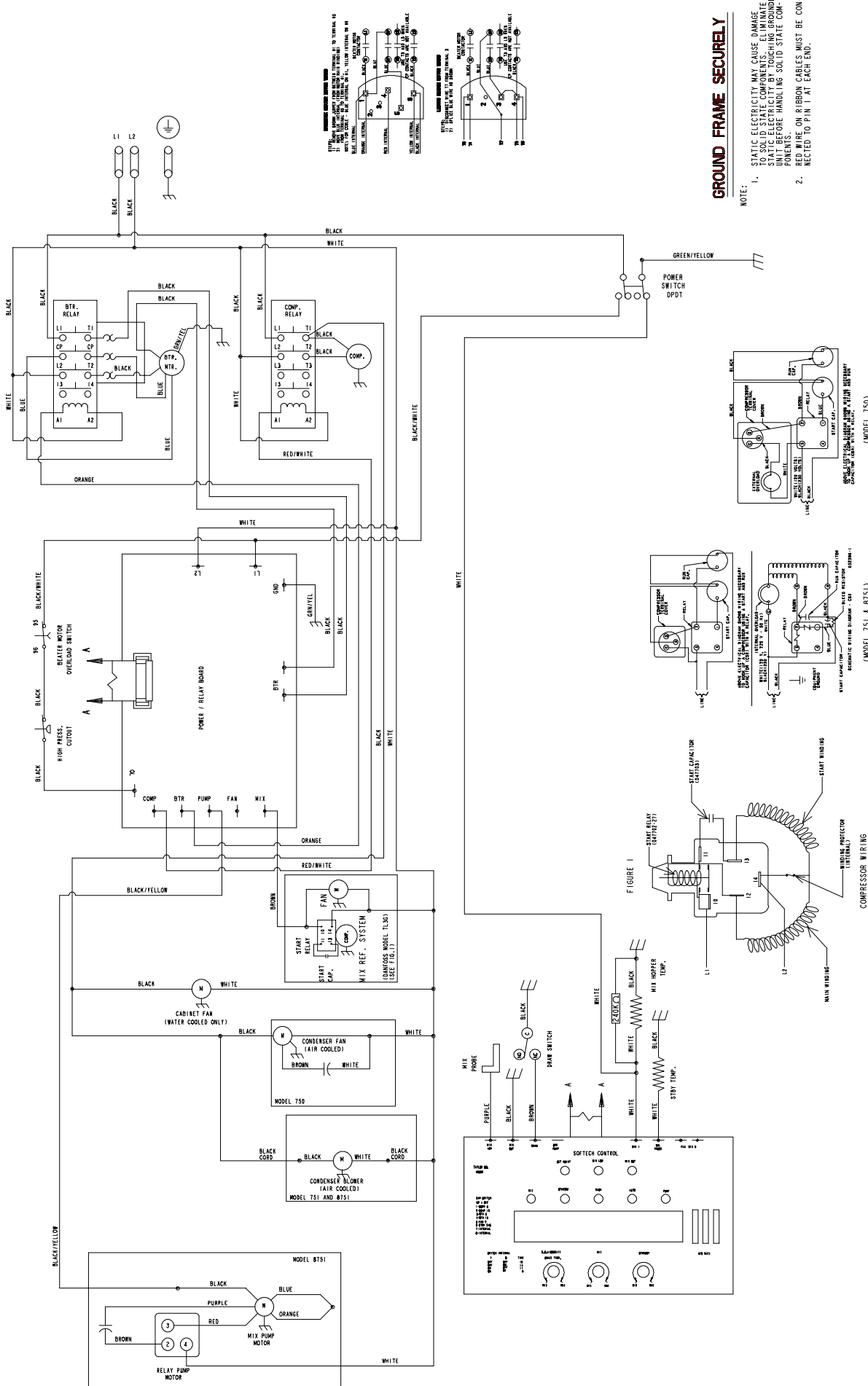

**GROUND FRAME SECURELY**

- NOTE:
1. STATIC ELECTRICITY MAY CAUSE DAMAGE TO SOLID STATE COMPONENTS. ELIMINATE STATIC ELECTRICITY BY TOUCHING GROUNDED POINTS BEFORE HANDLING SOLID STATE COMPONENTS.
  2. RED WIRE ON RIBBON CABLES MUST BE CONNECTED TO PIN 1 AT EACH END.



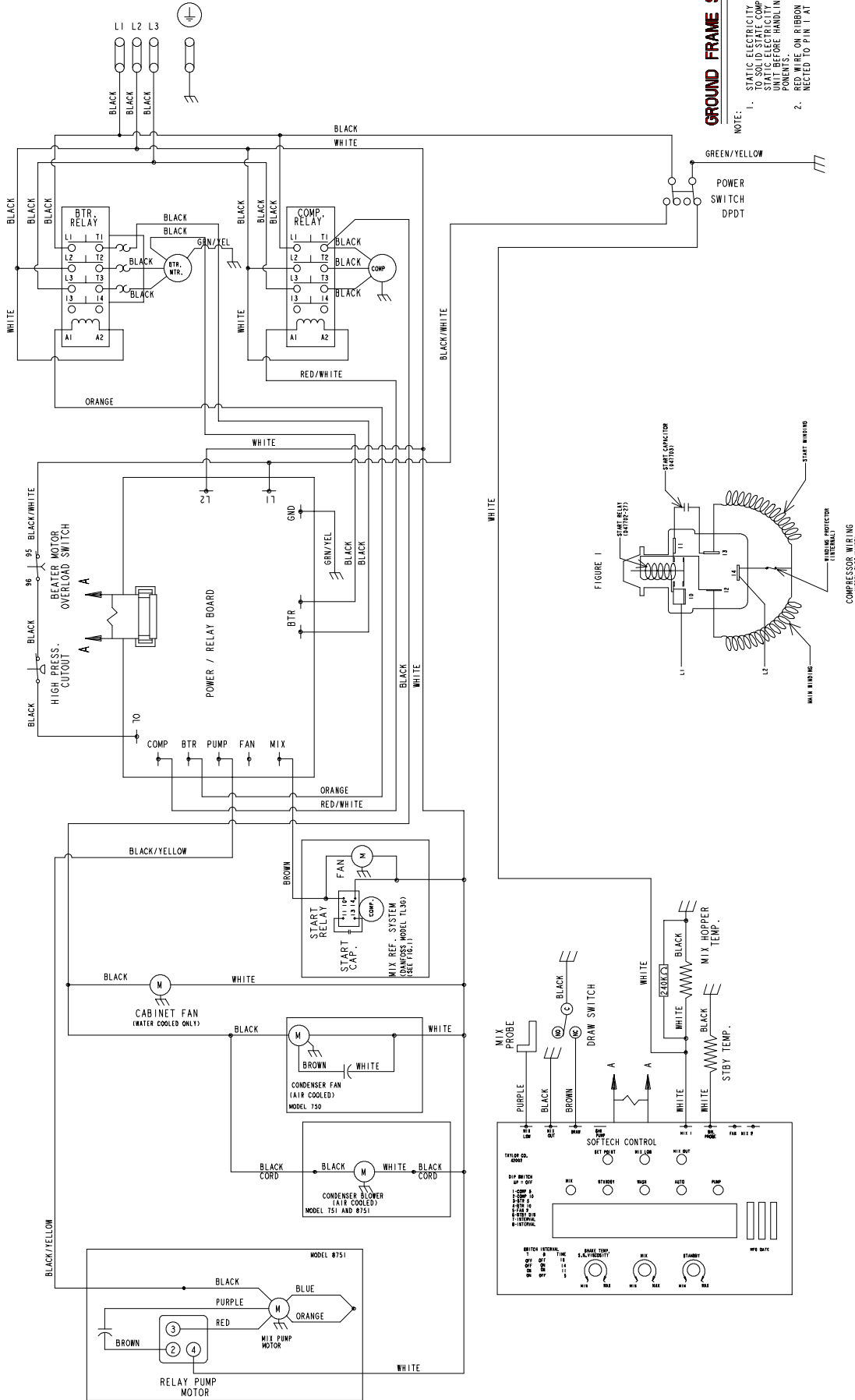

**GROUND FRAME SECURITY**

- NOTE:
1. STATIC ELECTRICITY MAY CAUSE DAMAGE TO SOLID STATE COMPONENTS. ELIMINATE STATIC BY TOUCHING THE GROUNDING POINT BEFORE HANDLING SOLID STATE COMPONENTS.
  2. RED WIRE ON RIBBON CABLES MUST BE CONNECTED TO PIN 1 AT EACH END.

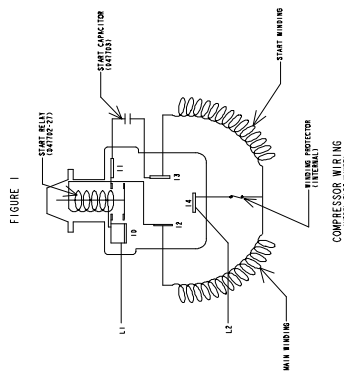

COMPRESSOR AND BEATER MOTOR PROTECTED UNDER PRIMARY SINGLE PHASING CONDITIONS

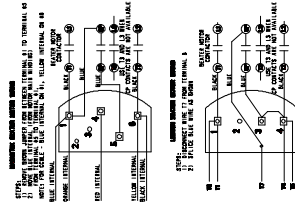

**GROUND FRAME SECURELY**

- NOTE:
1. STATIC ELECTRICITY MAY CAUSE DAMAGE TO SOLID STATE COMPONENTS. ELIMINATE STATIC ELECTRICITY BY DISCHARGING THE UNIT BEFORE HANDLING SOLID STATE COMPONENTS.
  2. RED WIRE ON RIBBON CABLES MUST BE CONNECTED TO PIN 1 AT EACH END.

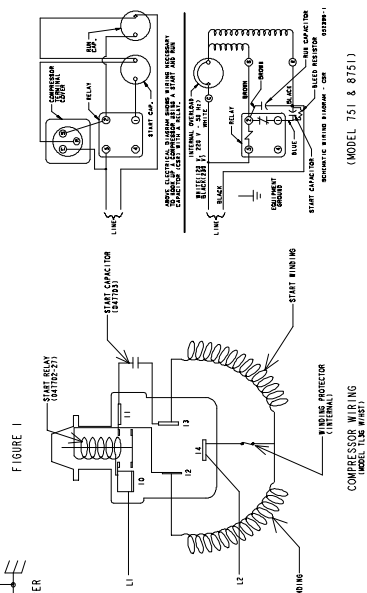
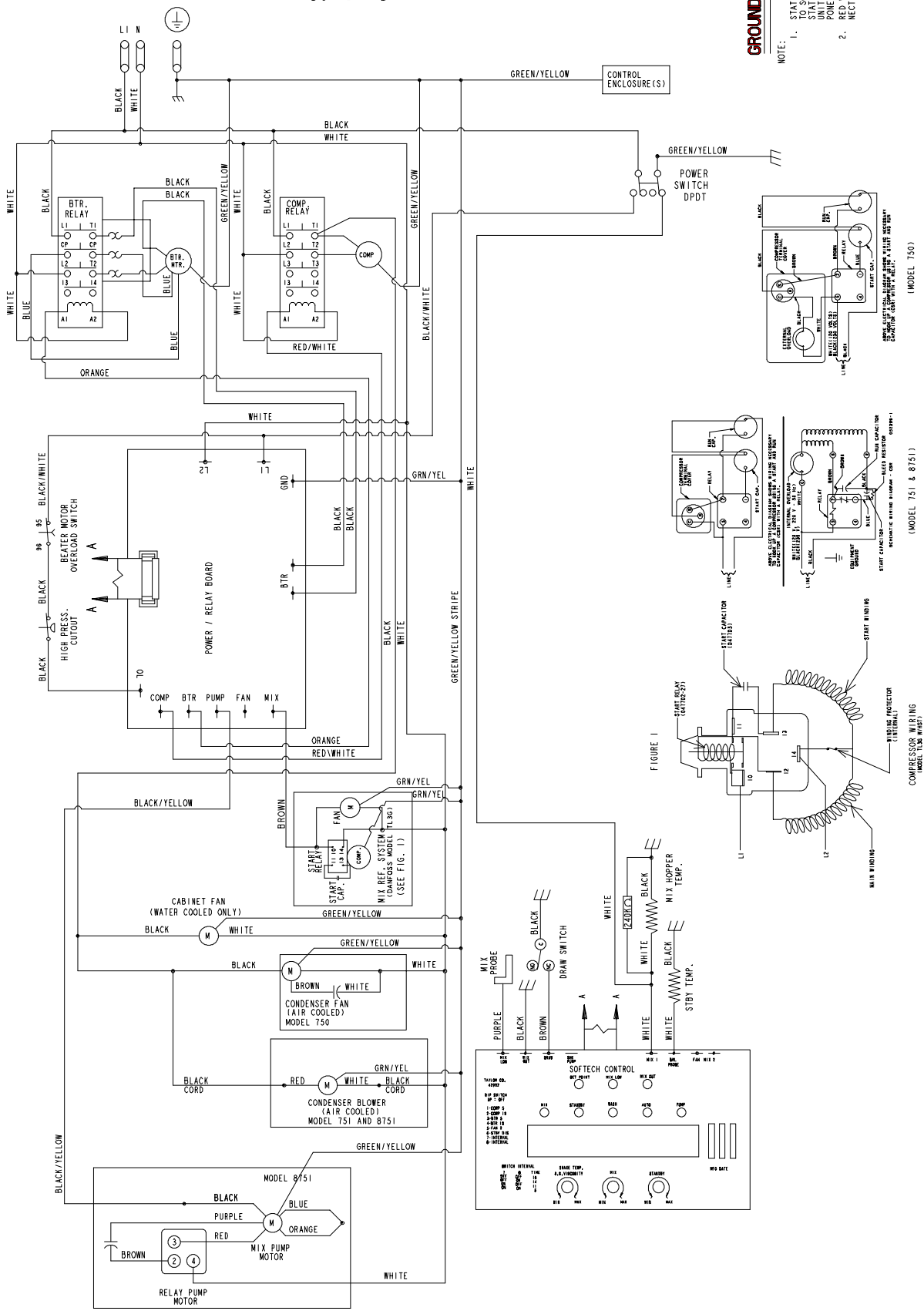

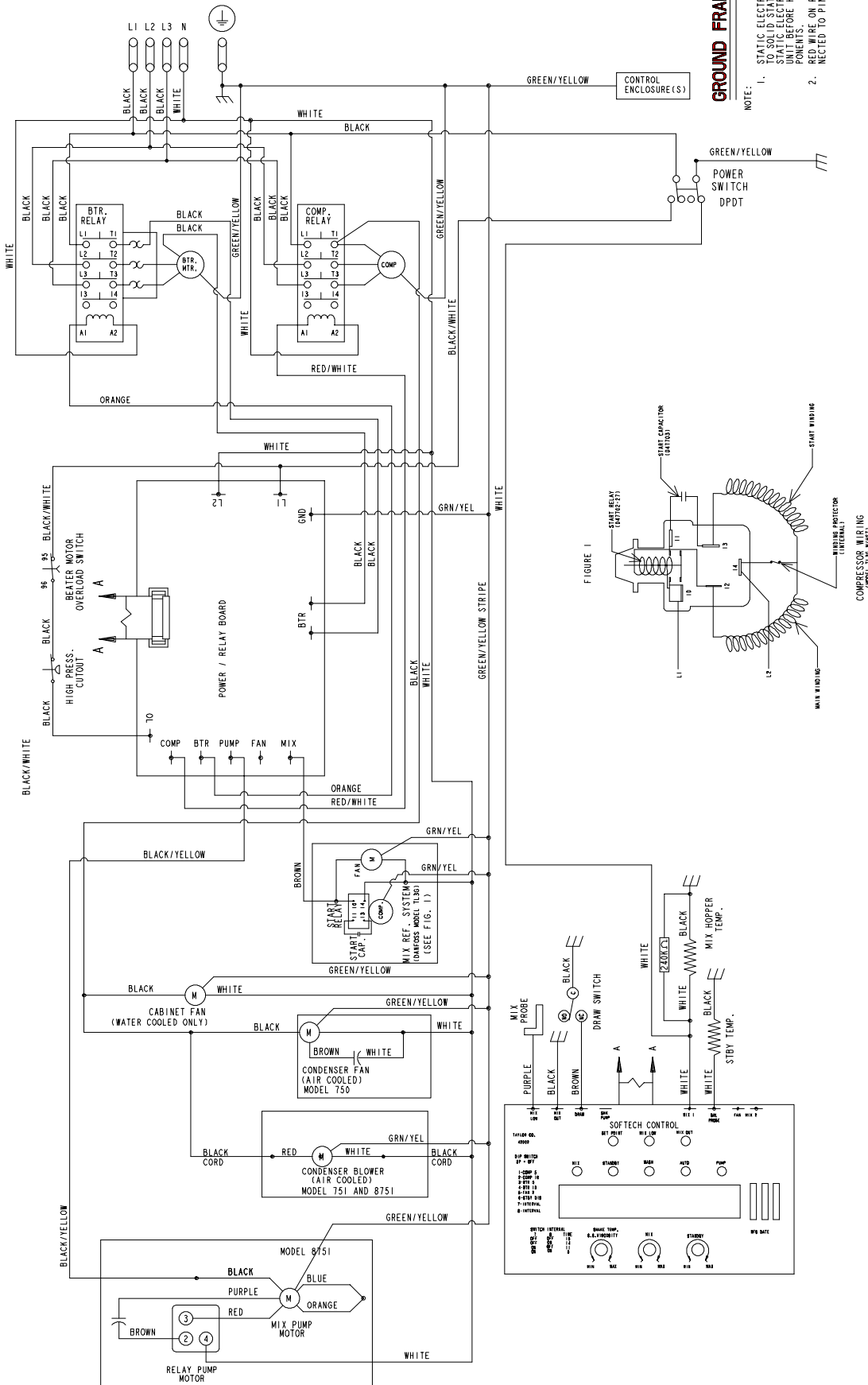

**GROUND FRAME SECURELY**

- NOTE:
1. STATIC ELECTRICITY MAY CAUSE DAMAGE TO THE ELECTRICAL COMPONENTS OF THIS UNIT. DISCHARGE STATIC ELECTRICITY FROM YOUR BODY BEFORE HANDLING SOLID STATE COMPONENTS.
  2. RED WIRE ON RIBBON CABLES MUST BE CONNECTED TO PIN 1 AT EACH END.

COMPRESSOR AND BEATER MOTOR PROTECTED UNDER PRIMARY SINGLE PHASING CONDITIONS

**GROUND FRAME SECURELY**

- NOTE:
1. STATIC ELECTRICITY MAY CAUSE DAMAGE TO SOLID STATE COMPONENTS. DISCHARGE ALL STATIC ELECTRICITY FROM YOUR BODY BEFORE HANDLING SOLID STATE COMPONENTS.
  2. RED WIRE ON RIBBON CABLES MUST BE CONNECTED TO PIN 1 AT EACH END.

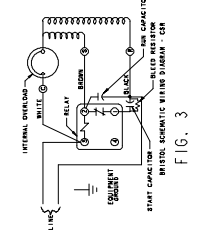
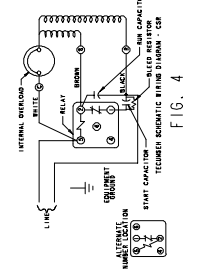
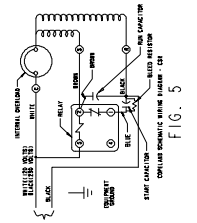
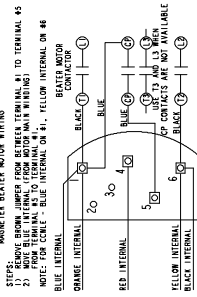
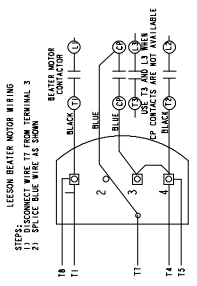
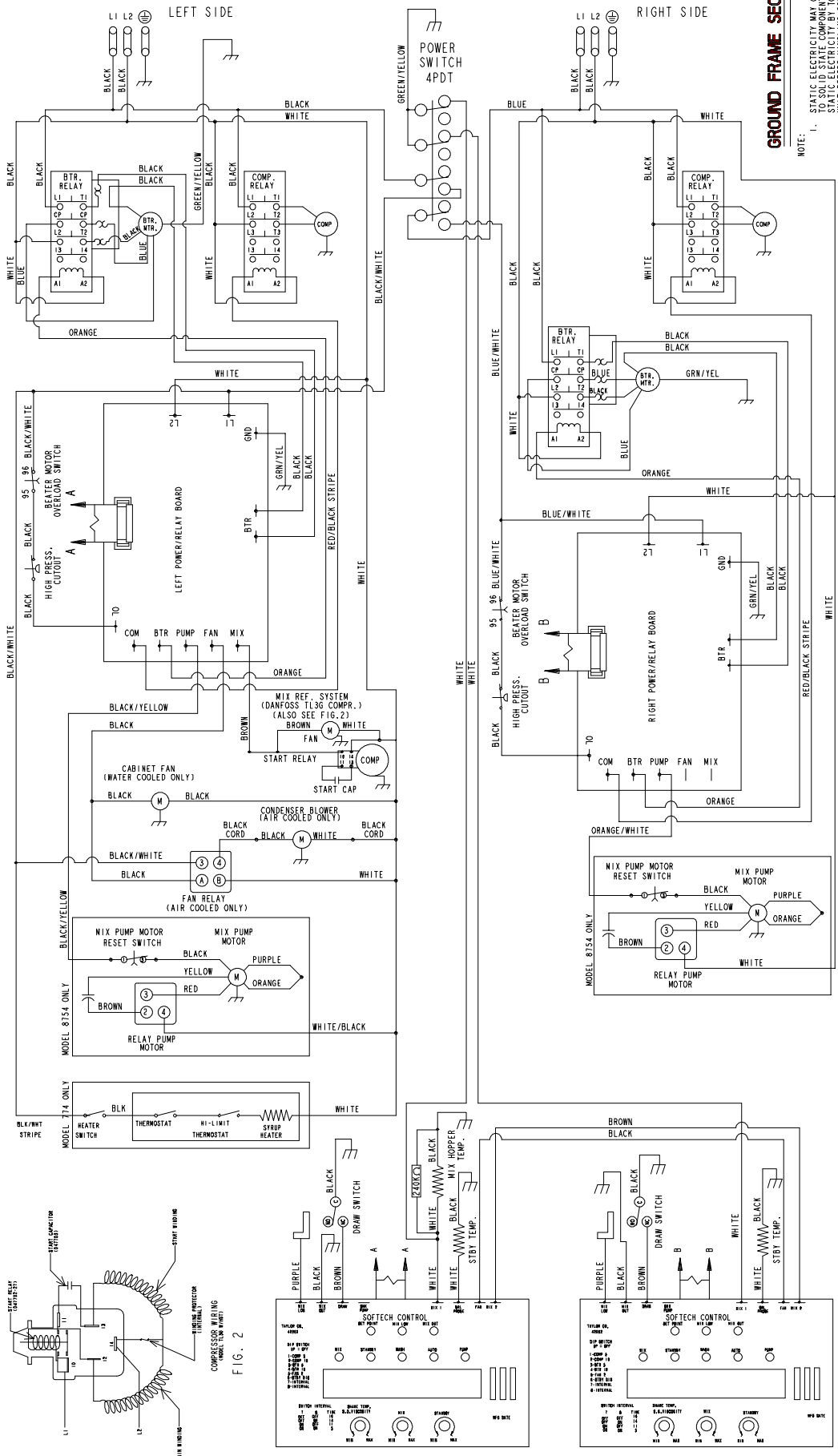

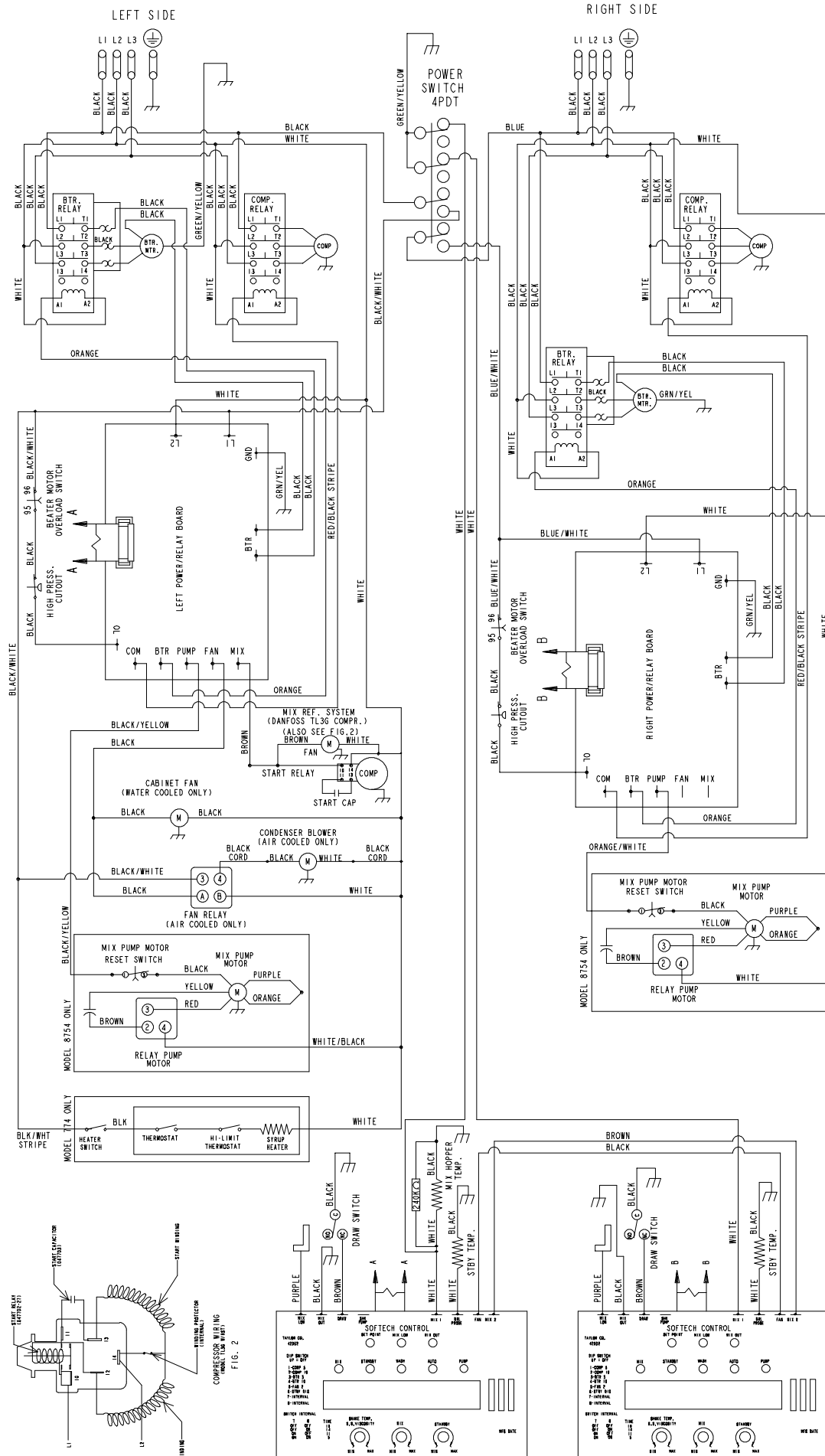

COMPRESSOR AND BEATER MOTOR PROTECTED  
UNDER PRIMARY SINGLE PHASING CONDITIONS

GROUND FRAME SECURELY