



# Front-Loading Automatic Washer

## PRODUCT MODEL NUMBERS

MHW6000X, MHW7000X,  
MHW9000X, MHW9000Y

**Electrical:** A 120 volt, 60 Hz., AC only, 15- or 20-amp, fused electrical supply is required. A time-delay fuse or circuit breaker is recommended. It is recommended that a separate circuit serving only this appliance be provided.

### Drain System Options

Drain system can be installed using a floor drain, wall standpipe, or laundry tub. Select method you need.

**IMPORTANT:** To avoid siphoning, 4.5" (113 mm) of drain hose should be inside standpipe or below the top of wash tub. Always secure drain hose with cable tie

### Floor standpipe drain system

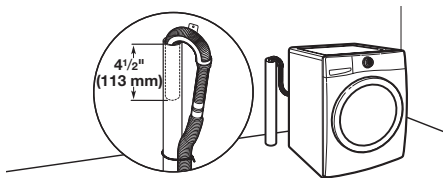

Minimum diameter for a standpipe drain: 2" (51 mm). Minimum carry-away capacity: 17 gal. (64 L) per minute. A 1/4" (6 mm) diameter to 1" (25 mm) diameter Top of standpipe must be at least 30" (762 mm) high; install no higher than 96" (2.44 m) from bottom of washer. If you must install higher than 96" (2.44 m), you will need a sump pump system.

### Wall standpipe drain system

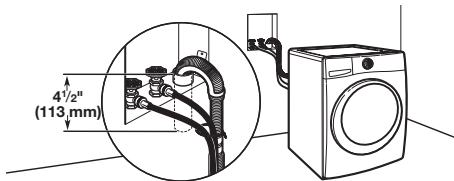

### Floor drain system

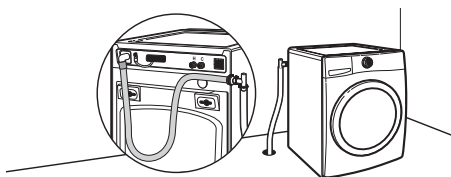

Floor drain system requires additional parts. Minimum siphon break: 28" (711 mm) from bottom of washer.

### Laundry tub drain system

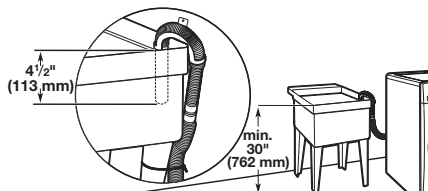

Minimum capacity: 20 gal. (76 L). Top of laundry tub must be at least 30" (762 mm) above floor; install no higher than 96" (2.44 m) from bottom of washer.

## OVERALL DIMENSIONS

### Washer dimensions

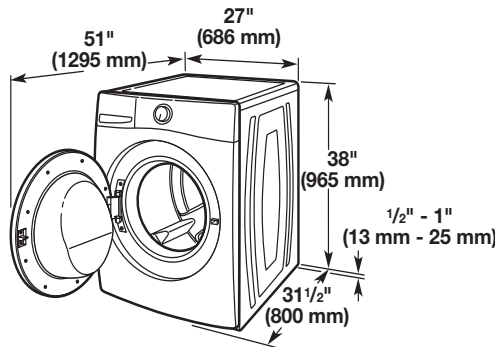

### Custom under counter installation:

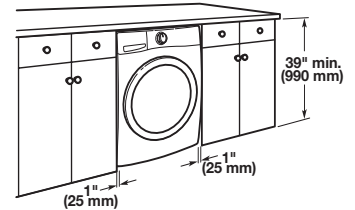

### Recessed area or closet installation (washer only):

All dimensions show recommended spacing allowed, except for closet door ventilation openings which are the minimum required.

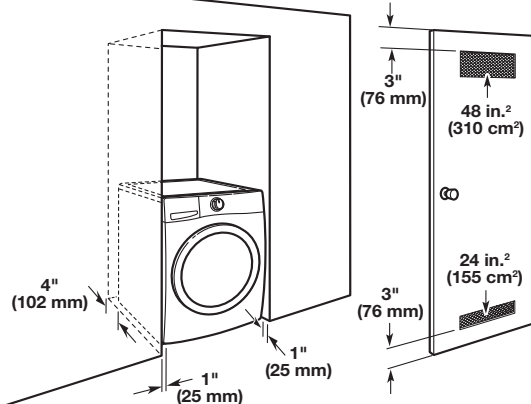

For each arrangement, consider allowing more space for ease of installation and servicing, and spacing for companion appliances and clearances for walls, doors, and floor moldings. Space must be large enough to allow door to fully open. Add spacing of 1" (25 mm) on all sides of washer to reduce noise transfer. If a closet door or louvered door is installed, top and bottom air openings in door are required.

### Recessed area or closet installation (stacked washer and dryer):

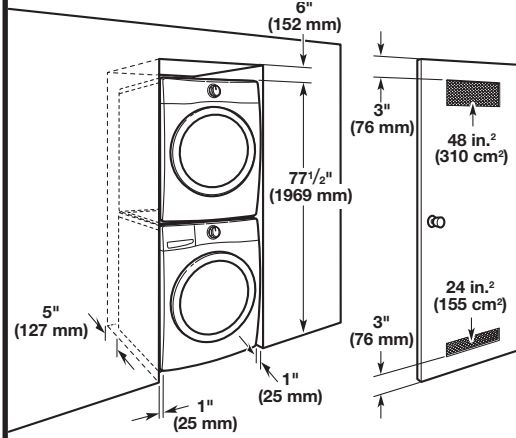

### Custom cabinet installation:

