

JVC

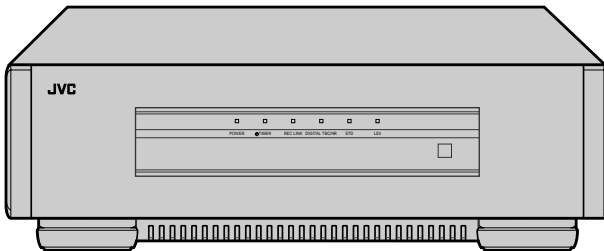

D-VHS DIGITAL RECORDER

HM-DR10000EK



VIDEO *Plus+* *Hi-Fi* **D** **VHS** MTP
PAL

INSTRUCTIONS

CONTENTS

SAFETY FIRST	2
Safety Precautions	2
Some Do's And Don'ts	4
QUICK SET UP GUIDE	5
CHECK THE CONTENTS	5
INSTALLATION	6
AUTO SET UP	8
T-V LINK	11
T-V LINK Functions	11
BASIC OPERATIONS	12
Playback	12
Recording	14
VIDEO Plus+®	
Timer Programming	18
Express Timer Programming	20
VIDEO NAVIGATION	24
Navigation	24
Title Editing	26
ADVANCED OPERATIONS	32
Recording According To	
Tape Type	32
Playback/Recording According	
To Tape Characteristics	34
Playback Picture Adjustment	36
Looking For The Scene You Want ...	37
Selecting the Sound You Want	38
Automatic Satellite Programme	
Recording	40
Remote Control Functions	42
Minimizing Picture Degradation	
While Editing	45
Edit From A Camcorder	46
Edit To Or From Another Video	
Recorder	48
Synchro Editing	51
Information On J Terminal	52
Other Functions	53
SYSTEM CONNECTIONS	57
Connection To A Stereo System	57
SUBSIDIARY SETTINGS	58
Tuner Set	58
VIDEO Plus+® Setup	65
Clock Set	66
SUBSIDIARY INFORMATION	68
Questions And Answers	68
Troubleshooting	69
Index	72
LIST OF TERMS	78
SPECIFICATIONS	Back Cover

Safety Precautions

The rating plate and the safety caution are on the rear of the unit.

WARNING: DANGEROUS VOLTAGE INSIDE

WARNING: TO PREVENT FIRE OR SHOCK HAZARD, DO NOT EXPOSE THIS UNIT TO RAIN OR MOISTURE.

IMPORTANT

- Please read the various precautions on p. 2 – 4 of this instruction manual before installing or operating the recorder.
- It should be noted that it may be unlawful to re-record pre-recorded tapes, records, or discs without the consent of the owner of copyright in the sound or video recording, broadcast or cable programme and in any literary, dramatic, musical, or artistic work embodied therein.

IMPORTANT

Connection to the mains supply in the United Kingdom.

DO NOT cut off the mains plug from this equipment. If the plug fitted is not suitable for the power points in your home or the cable is too short to reach a power point, then obtain a proper safety approved extension lead/adaptor or consult your dealer.

In the unlikely event of the plug fuse failing be sure to replace the fuse only with an identical approved type, as originally fitted, and to replace the fuse cover. If the fuse fails again consult your nearest JVC dealer.

If nonetheless the mains plug is cut off remove the fuse and dispose of the plug immediately, to avoid a possible shock hazard by inadvertent connection to the mains supply.

If this product is not supplied fitted with a mains plug then follow the instructions given below:

DO NOT make any connection to the Larger Terminal coded E or Green.

The wires in the mains lead are coloured in accordance with the following code:

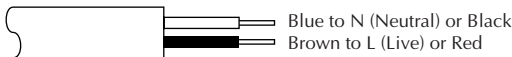

If these colours do not correspond with the terminal identifications of your plug, connect as follows:

Blue wire to terminal coded N (Neutral) or coloured Black.

Brown wire to terminal coded L (Live) or coloured Red.

If in doubt — consult a competent electrician.

CAUTION

- To avoid electric shock or damage to the unit, first firmly insert the small end of the mains power cord into the recorder until it is no longer wobbly, and then plug the larger end of the mains power cord into a mains outlet.
- When you are not using the recorder for a long period of time, it is recommended that you disconnect the power cord from the mains outlet.
- Dangerous voltage inside. Refer internal servicing to qualified service personnel. To prevent electric shock or fire hazard, remove the power cord from the mains outlet prior to connecting or disconnecting any signal lead or aerial.

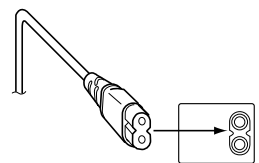

- Cassettes marked "D-VHS", "S-VHS" and "VHS" can be used with this video cassette recorder. However, D-VHS recordings are possible only with cassettes marked "D-VHS".
- D-VHS is a new digital memory system that uses D-VHS tapes. D-VHS was developed as a memory system for multimedia applications that require storage for large volumes of information, such as for digital video.
- VIDEO Plus+ and PlusCode are registered trademarks of Gemstar Development Corporation. The VIDEO Plus+ system is manufactured under license from Gemstar Development Corporation.

The STANDBY/ON \cup /I button does not completely shut off mains power from the unit, but switches operating current on and off. " \cup " shows electrical power standby and " I " shows ON.

Video tapes recorded with this video recorder in the LP (Long Play) mode cannot be played back on a single-speed video recorder.

Failure to heed the following precautions may result in damage to the recorder, remote control or video cassette.

1. **DO NOT** place the recorder . . .

- ... in an environment prone to extreme temperatures or humidity.
- ... in direct sunlight.
- ... in a dusty environment.
- ... in an environment where strong magnetic fields are generated.
- ... on a surface that is unstable or subject to vibration.

2. **DO NOT** block the recorder's ventilation openings.

3. **DO NOT** place heavy objects on the recorder or remote control.

4. **DO NOT** place anything which might spill on top of the recorder or remote control.

5. **AVOID** violent shocks to the recorder during transport.

MOISTURE CONDENSATION

Moisture in the air will condense on the recorder when you move it from a cold place to a warm place, or under extremely humid conditions—just as water droplets form in the surface of a glass filled with cold liquid. Moisture condensation on the head drum will cause damage to the tape. In conditions where condensation may occur, keep the recorder turned on for a few hours to let the moisture dry.

ABOUT HEAD CLEANING

After an extended period of use, the video heads can become dirty, resulting in a loss of picture or sound during playback. If this happens, clean the video heads by using the optional cleaning tapes.

Symptoms of dirty video heads:

- The picture is not clear, or does not appear.
There is no sound.
- Mosaic (block) noise appears in the picture.
- Black or mosaic horizontal stripes appear in the picture.
- The picture stops (as if the tape is paused).
- A blank black or blue screen appears.
- The picture is fuzzy. (VHS playback)

VHS playback



Early symptom



Late symptom

D-VHS playback



Block noise



Still image



Black screen

Use a cleaning tape designed specifically for D-VHS video heads (JVC D-VHS video head cleaner DFC-2) to clean the video heads.

- In order to avoid misoperation, set "NAVIGATION" to "OFF" (☞ pg. 25).
- Follow the instructions that are provided with the cleaning tape.

If you still do not get a clear picture after using a cleaning tape:

- The heads may be worn. Contact your nearest JVC dealer.
- During VHS playback, if there is a tracking problem, the picture may appear fuzzy. Adjust the tracking manually (☞ pg. 36).

Some Do's And Don'ts On The Safe Use Of Equipment

This equipment has been designed and manufactured to meet international safety standards but, like any electrical equipment, care must be taken if you are to obtain the best results and safety is to be assured.

- DO** read the operating instructions before you attempt to use the equipment.
- DO** ensure that all electrical connections (including the mains plug, extension leads and interconnections between pieces of equipment) are properly made and in accordance with the manufacturer's instructions. Switch off and withdraw the mains plug when making or changing connections.
- DO** consult your dealer if you are ever in doubt about the installation, operation or safety of your equipment.
- DO** be careful with glass panels or doors on equipment.
- DON'T** continue to operate the equipment if you are in any doubt about it working normally, or if it is damaged in any way — switch off, withdraw the mains plug and consult your dealer.
- DON'T** remove any fixed cover as this may expose dangerous voltages.
- DON'T** leave equipment switched on when it is unattended unless it is specifically stated that it is designed for unattended operation or has a standby mode. Switch off using the switch on the equipment and make sure that your family knows how to do this. Special arrangements may need to be made for infirm or handicapped people.
- DON'T** use equipment such as personal stereos or radios so that you are distracted from the requirements of road safety. It is illegal to watch television whilst driving.
- DON'T** listen to headphones at high volume, as such use can permanently damage your hearing.
- DON'T** obstruct the ventilation of the equipment, for example with curtains or soft furnishings. Overheating will cause damage and shorten the life of the equipment.
- DON'T** use makeshift stands and NEVER fix legs with wood screws — to ensure complete safety always fit the manufacturer's approved stand or legs with the fixings provided according to the instructions.
- DON'T** allow electrical equipment to be exposed to rain or moisture.

ABOVE ALL...

- **NEVER** let anyone especially children push anything into holes, slots or any other opening in the case — this could result in a fatal electrical shock;
- **NEVER** guess or take chances with electrical equipment of any kind — it is better to be safe than sorry!

Dear Customer,

Thank you for purchasing this JVC Video Cassette Recorder.

Please use this **QUICK SET UP GUIDE** to help you to set up your video cassette recorder.

STEP

1

CHECK THE CONTENTS

CHECK ALL THE CONTENTS SHOWN BELOW

Video Cassette Recorder

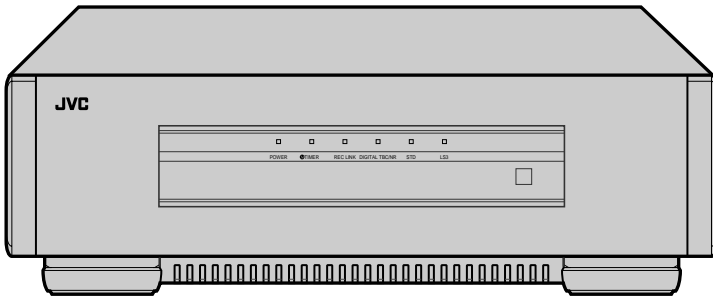

RF Cable

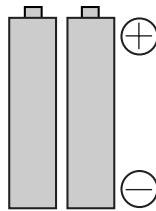

"AA" Batteries (x 2)

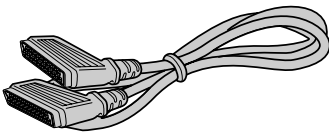

21-pin SCART Cable

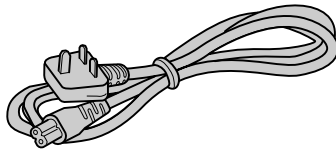

Power Cord



Infrared Remote Control Unit

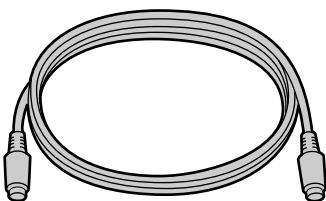

S-Video Cable

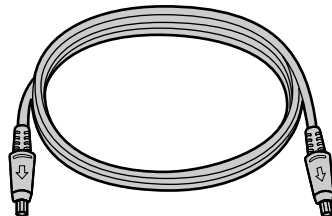

DV Cable

▶ You are now ready to install your video recorder.

STEP

2

INSTALLATION

CONNECT VIDEO RECORDER TO TV

- Place the recorder on a stable, flat surface.

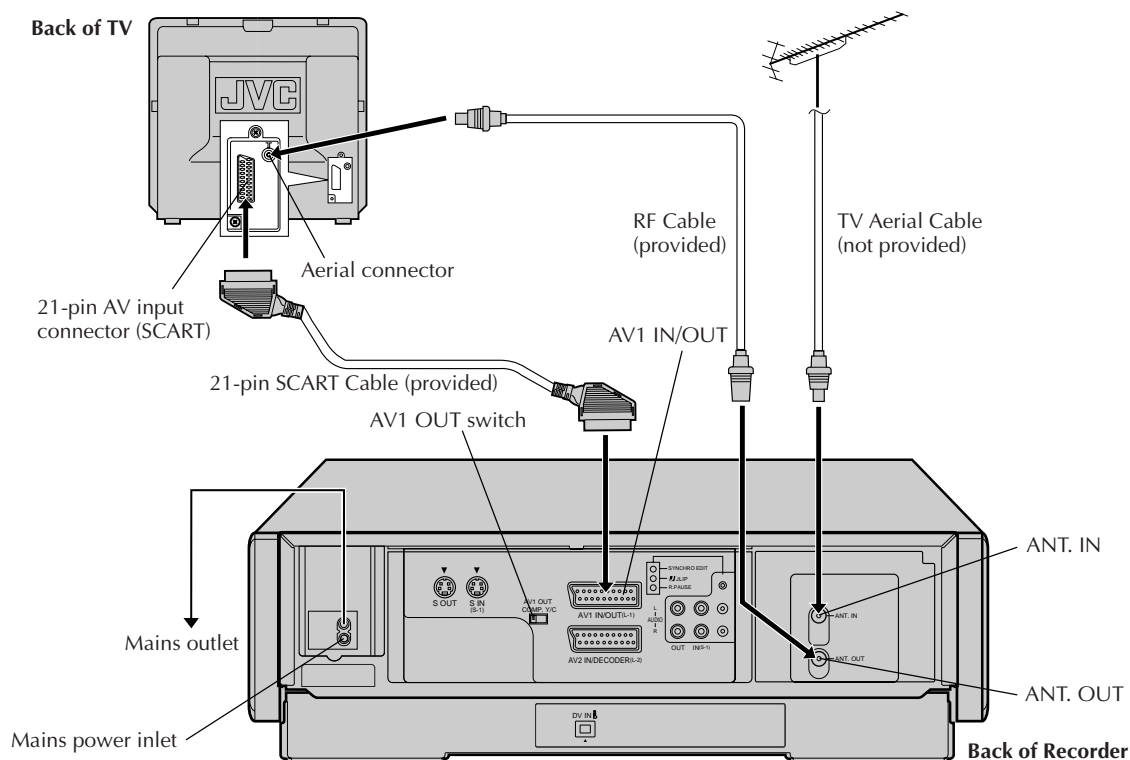
**ATTENTION:**

You can not use the recorder connected to your TV only with the RF cable. This is because the RF cable does not deliver signal from the recorder. Your TV must have a 21-pin AV input connector (SCART) to connect to the recorder.

AV CONNECTION

To connect to a TV with 21-pin AV input connector (SCART) . . .

- 1- Disconnect the TV aerial cable from the TV.
- 2- Connect the TV aerial cable to the ANT. IN jack on the rear panel of the recorder.
- 3- Connect the provided RF cable between the ANT. OUT jack on the rear panel of the recorder and the TV's aerial connector.
- 4- Connect the provided SCART cable between the AV1 IN/OUT socket on the rear panel of the recorder and the TV's 21-pin AV input connector (SCART).
- 5- Set the **AV1 OUT** switch to the appropriate position. See "AV1 INPUT/OUTPUT SIGNAL SELECTION FOR AV CONNECTION" below.

AV1 INPUT/OUTPUT SIGNAL SELECTION FOR AV CONNECTION

The AV1 IN/OUT connector accepts and delivers either a composite signal (regular video signal) or a Y/C signal (a signal in which the luminance and chrominance signals are separated). For input signal selection, select "VIDEO" (regular video signal) or "S-VIDEO" (Y/C signal) for "AV1 SELECT" setting (☞ pg. 50). For output signal selection, use the **AV1 OUT** switch on the rear panel.

- If your TV's 21-pin AV input connector (SCART) is compatible only with the regular video signal, set this switch to COMP.
- If your TV's 21-pin AV input connector (SCART) is compatible with the Y/C signal, set this switch to Y/C. You can obtain high-quality S-VHS pictures. (For connection, be sure to use a 21-pin SCART cable that is compatible with the Y/C signal.)

NOTES:

- Set your TV to the VIDEO (or AV), Y/C, or RGB mode according to the type of your TV's SCART connector.
- For switching the TV's mode, refer to the instruction manual of your television.
- To obtain high-quality S-VHS pictures, you can also use the S-VIDEO CONNECTION described on page 7.

ATTENTION

- Do NOT plug the mains power cord into a mains outlet until all connections are completed.
- Do NOT press the $\odot/|$ button on the recorder or on the remote control to turn on the recorder's power before you start the Auto Set Up procedure described on page 8.

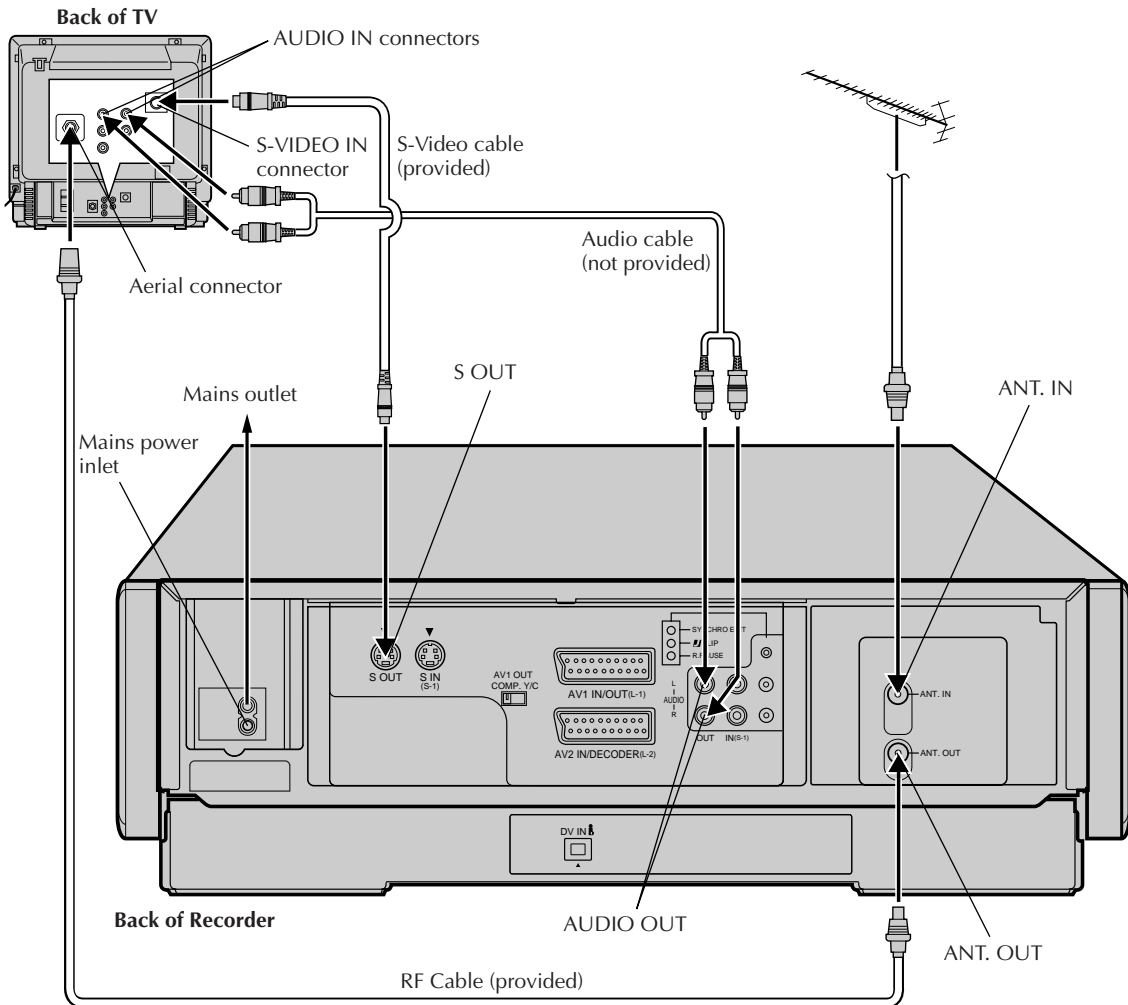

S-VIDEO CONNECTION

To connect to a TV with S-VIDEO/AUDIO IN connectors . . .

- 1- Connect the aerial, recorder and TV as per "AV CONNECTION" (pg. 6).
- 2- Connect the recorder's S OUT connector to the TV's S-VIDEO IN connector.
- 3- Connect the recorder's AUDIO OUT connectors to the TV's AUDIO IN connectors.

NOTES:

- You can obtain high-quality S-VHS pictures.
- If your television is not stereo-capable, use the recorder's AUDIO OUT connectors to connect to an audio amplifier for Hi-Fi stereo sound reproduction. (pg. 57)
- To operate the recorder with your TV using the S-VIDEO connection, set your TV to the AV mode.
- For switching the TV's mode, refer to the instruction manual of your television.

ATTENTION

- Do NOT plug the mains power cord into a mains outlet until all connections are completed.
- Do NOT press the ψ /I button on the recorder or on the remote control to turn on the recorder's power before you start the Auto Set Up procedure described on page 8.

AFTER YOU FINISH THIS STEP

Go to Step 3 – AUTO SET UP

STEP

3 AUTO SET UP

SET THE TUNER CHANNELS, CLOCK AND GUIDE PROGRAM NUMBERS

The Auto Set Up function sets the tuner channels, clock and Guide Program numbers assigned by the VIDEO Plus+ system automatically the first time the $\psi/1$ button on the recorder or on the remote is pressed to turn on the recorder after the mains power cord has been plugged into a mains outlet.

Before performing the following procedure, make sure that:

- the TV aerial cable is connected to the recorder.
- the mains power cord is plugged into the mains outlet.
- batteries have been installed in the remote control.

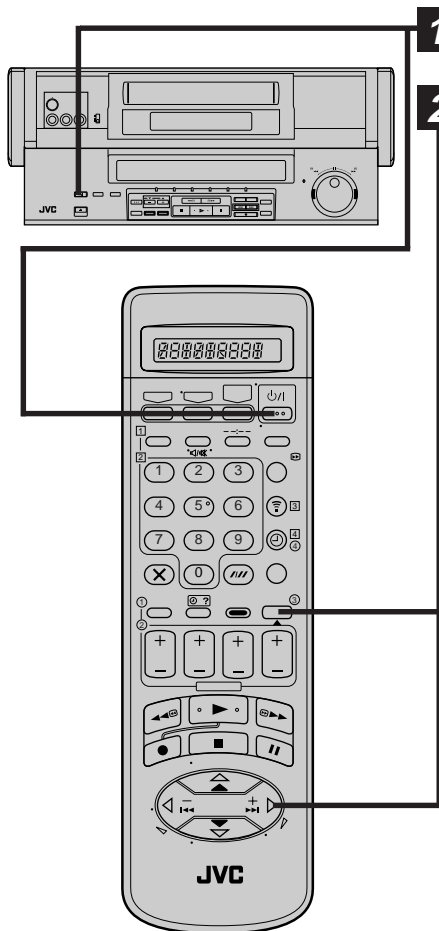

1 Press $\psi/1$ to turn on the recorder.

2 If "Auto" appears on the display panel, press **OK** or \triangleright . "Auto" blinks; DO NOT press any button on the recorder or remote control until the display panel shows clock time, "(PR) 1" or "- :- -" as illustrated on page 10. Auto Set Up usually takes about 4 – 12 minutes; the duration varies by area.

- If you are using the on-screen display, the AUTO SET screen will appear. As Auto Set Up progresses, the "■" mark on the screen moves from left to right.

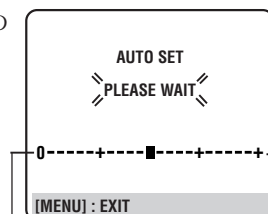

Beginning

End

ATTENTION

Once you have performed Auto Set Up, all the stored stations and Guide Program numbers remain in the recorder's memory and the recorder will not perform Auto Set Up again. If there is a power cut and the recorder's memory backup expires you only need to reset the clock. (☞ pg. 66)

If you have moved to a different area, perform each setting as required.

- Tuner setting ☞ pg. 58
- Clock setting ☞ pg. 66

If a new station begins broadcasting in your area, perform tuner setting (☞ pg. 58).

NOTES:

- Auto channel set function takes place first; it assigns automatically all receivable stations in your area.
- Auto clock set function sets the clock automatically.
- During auto channel set, the recorder recognizes each station name of the detected stations and stores them in the recorder's memory, then automatically sets the Guide Program numbers assigned by the VIDEO Plus+ system for those stations according to the broadcast area.
- If there is a power cut or if you press $\psi/1$ or **MENU** while Auto Set Up is in progress, Auto Set Up will be interrupted; be sure to turn off the recorder power once and press $\psi/1$ to turn the power back on in order to re-start Auto Set Up.

PRESET DOWNLOAD

SET THE TUNER CHANNELS BY DOWNLOADING FROM YOUR TV, CLOCK AND GUIDE PROGRAM NUMBERS

When you connect the recorder and your TV via fully-wired 21-pin SCART cable (☞ pg. 6), you can set the recorder's tuner channels by downloading preset data from your TV instead of using the Auto Set Up function (☞ pg. 8). After downloading is completed, the recorder sets the clock and Guide Program numbers assigned by the VIDEO Plus+ system automatically. For details, refer to the instruction manual for your TV.

ATTENTION

You can use this function only with a TV offering T-V Link, etc.*

* Compatible with TVs offering T-V Link, EasyLink, Megalogic, SMARTLINK, Q-Link, DATA LOGIC or NEXTVIEWLINK via fully-wired 21-pin SCART cable. The degree of compatibility and available functions may differ by system.

Before performing the following procedure, make sure that:

- the TV aerial cable is connected to the recorder and a 21-pin SCART cable is connected between your TV and the recorder.
- the mains power cord is plugged into the mains outlet.
- batteries have been installed in the remote control.

1 Press \mathcal{P} /I to turn on the recorder.

2 If "Auto" appears on the display panel, Press Δ / ∇ to select "CH --" and press **OK** or \triangleright . Preset position on the display panel increases from "CH1"; do NOT press any button on the recorder or remote control until the display panel shows clock time, "(PR) 1" or "--:--" as illustrated on page 10.

- If you are using the on-screen display, the T-V LINK screen will appear. Then the GUIDE PROG SET screen will appear during Guide Program number set.
- If you press any button on the recorder or remote control while downloading is in progress, this process will be interrupted and you will need to start again. See NOTES below.

NOTES:

- In areas where no TV station transmits the PDC signal, the recorder cannot perform either auto clock set or auto Guide Program number set.
- If there is a power cut, or if you press \mathcal{P} /I or **MENU** while downloading or set up is in progress, it will be interrupted; be sure to turn off the recorder power once and try again from the beginning.
- Auto clock may not function properly depending on reception conditions.
- When you perform T-V LINK function, be sure to use fully-wired 21-pin SCART cable.
- On this recorder, the characters available for station names (ID) are A-Z, 0-9, -, *, + and $_$ (space). The names of some downloaded stations may differ from those on your TV (☞ pg. 62).

Auto Set Up results appear on the display panel

A When both auto channel set and auto clock set have been completed successfully the correct current time will be displayed.



B When auto channel set has been completed successfully but auto clock set has not, "(PR)1" will be displayed.



C When neither auto channel set nor auto clock set has been completed successfully, "--:--" will be displayed.

* You can check if the Guide Program numbers have been set correctly when you perform the VIDEO Plus+ Timer Programming (☞ pg. 18); if the correct preset position number is displayed in step 3, this confirms that the Guide Program number for the PlusCode number you enter in step 2 has been set correctly.

A If both auto channel set and auto clock set have been performed successfully:

- 1 Turn on the TV and select its AV mode, then make sure that all necessary stations have been stored in the recorder's memory by using the **TV PROG** button(s).
 - If station names (ID — ☞ pg. 63) have also been stored in the recorder's memory, the station name will be displayed at the top left corner of the screen for about 5 seconds each time the recorder is tuned to a different station.
 - If you want to set the tuner manually such as to add or skip channels, to change preset positions, or to set or change station names, see pages 60 – 62.

Now you have finished the basic set up and can use your recorder for both playback and recording.

B If auto channel set has succeeded but auto clock set has not:

- 1 Turn on the TV and select its AV mode, then make sure that all necessary stations have been stored in the recorder's memory by using the **TV PROG** button(s).
 - If station names (ID — ☞ pg. 63) have also been stored in the recorder's memory, the station name will be displayed at the top left corner of the screen for about 5 seconds each time the recorder is tuned to a different station.
 - If you want to set the tuner manually such as to add or skip channels, to change preset positions, or to set or change station names, see pages 60 – 62.
- 2 Perform "Clock Set" on page 66.

Now you have finished the basic set up and can use your recorder for both playback and recording.

C If both auto channel set and auto clock set have failed:

- 1 Make sure the TV aerial cable is connected properly to the recorder and turn off the recorder power once, then turn the recorder power back on again.
- 2 Perform "Auto Set Up" on page 8 or "Preset Download" on page 9.

IMPORTANT

- In certain reception conditions, station names may not be stored correctly, and auto Guide Program Number Set may not work properly. If the Guide Program numbers are not set properly, when you timer-record a TV programme using the VIDEO Plus+ system, the recorder will record a TV programme of a different station. When programming the timer using the VIDEO Plus+ system, be sure to check that the preset position corresponding to the broadcasting station you wish to record has been selected (☞ pg. 18, "VIDEO Plus+® Timer Programming").
- Your video recorder memorizes all detected stations even if reception of some of them is poor. In these cases picture quality may be poor. To delete those stations which have an unacceptable picture ☞ "Delete A Channel" on page 61.
- If any of the above problems occur, refer to pages 60 – 62 to input station names (☞ "Set Stations") or delete unnecessary stations (☞ "Delete A Channel"). You can also change station preset positions (☞ "Change Station Preset Position").

If you have any difficulty with the above procedures call the JVC Customer Service Hot Line on 0208 208 7654

T-V Link Functions

When you connect the recorder and your TV via a fully-wired 21-pin SCART cable (☞ pg. 6), the following functions are available. You can use these functions only with a TV offering T-V Link, etc.*

For details, refer to the instruction manual for your TV.

* Compatible with TVs offering T-V Link, EasyLink, Megalogic, SMARTLINK, Q-Link, DATA LOGIC or NEXTVIEWLINK via fully-wired 21-pin SCART cable. The degree of compatibility and available functions may differ by system.

NextView Link

You can download the EPG (Electronic Programme Guide) information from your TV for timer-programming on the recorder.

For details, refer to the instruction manual for your TV.

TV Auto Power On

You can turn on the TV and set it to video mode automatically whenever you play a tape.

For details, refer to the instruction manual for your TV.

VCR Auto Standby

You can use your TV's remote control to turn off the recorder.

For details, refer to the instruction manual for your TV.

Direct Rec

You can start recording the programme that you are watching on your TV with simple operation. Press and hold **RECORD** and press **PLAY** on the remote control, or press **RECORD** on the recorder.

Follow the procedure below to use this function.

1 TURN ON THE RECORDER

Press **ON/OFF**.

2 ACCESS MAIN MENU SCREEN

Press **MENU**.

3 ACCESS MODE SET SCREEN

Press **Δ∇** to move the highlight bar (pointer) to "MODE SET", then press **OK** or **▷**.

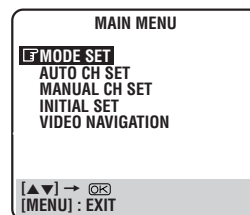

4 SELECT DIRECT REC MODE

Press **Δ∇** to move the highlight bar (pointer) to "DIRECT REC", then press **OK** or **▷** to set to "ON".

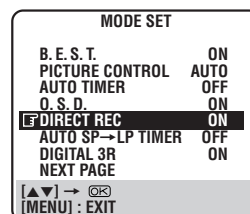

5 RETURN TO NORMAL SCREEN

Press **MENU**.

NOTES:

- If "DIRECT REC" is set to "OFF", the **RECORD** button functions as described in "Recording" (☞ pg. 14).
- During the Direct Rec, "--" appears on the display panel.
- When you perform T-V LINK functions, be sure to use a fully-wired 21-pin SCART cable.

Playback

Turn on the TV and select the AV mode.

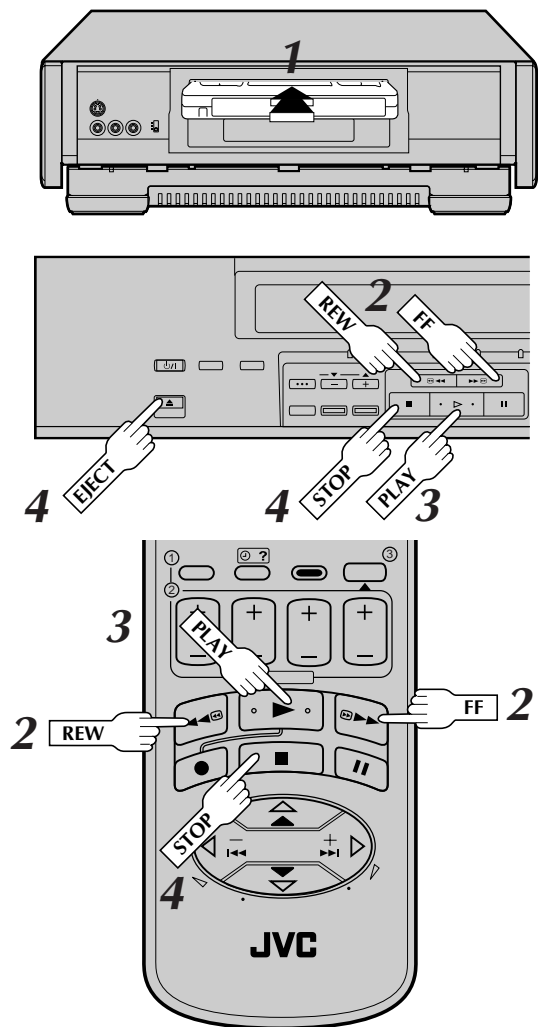

Tape Position Indicator

The tape position indicator appears on screen when, from the Stop mode, you press **FF**, **REW** or perform an Index Search. The position of "■" in relation to "0" (beginning) or "+" (end) shows you where you are on the tape.

"O.S.D." (pg. 53) must be set to "ON", or the indicator will not appear.

NOTE:

Depending on the type of tape used, there may be times when the indication is not correct.

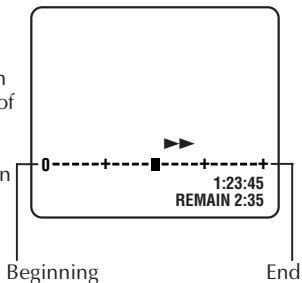

The easiest, most basic operation possible with your video recorder is tape playback. Already-recorded signals on a video tape are read by your video recorder and displayed on your TV just like a TV programme.

- This recorder can play back tapes that have been recorded in D-VHS (MTP), S-VHS and VHS formats.
- When playing back a tape, this recorder automatically identifies the recording format (D-VHS, S-VHS, or VHS).

LOAD A CASSETTE

1

Make sure the window side is up, the rear label side is facing you and the arrow on the front of the cassette is pointing towards the recorder. Don't apply too much pressure when inserting.

- The recorder power comes on automatically and the counter is reset to 0:00:00.
- While "----" is blinking on the front display panel, the tape will run for a few seconds to search for the tape number.
- If the record safety tab has been removed, playback begins automatically.

FIND PROGRAMME START POINT

2

If the tape is advanced past the start point, press **REW**. To go forward, press **FF**.

START PLAYBACK

3

Press **PLAY**. "BEST" appears blinking in the recorder's display panel during automatic tracking (only cassettes recorded in the S-VHS or VHS mode (pg. 34)).

- Playback picture quality of LP recordings will not be as high as SP recordings.

STOP PLAYBACK

4

Press **STOP**. Then press **EJECT** to remove the cassette.

INFORMATION

When using the AV connection (pg. 6), initiating playback causes the VCR indicator to light and the TV to automatically enter AV mode. To return the TV to TV mode after playback is complete, press **TV/VCR** so that the VCR indicator turns off.

* Depending on the type of TV used, **TV/VCR** button does not always function as described above.

NOTE:

Compact VHS camcorder recordings can be played on this video recorder. Simply place the recorded cassette into a VHS Cassette Adapter and it can be used just like any full-sized VHS cassette.

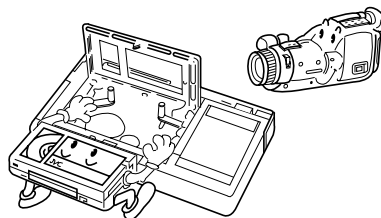

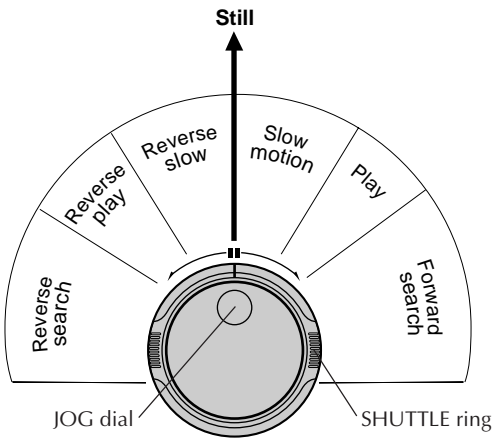

Possible operations on this page for tapes recorded in D-VHS mode:

- Still picture during playback by pressing **PAUSE**.
- High-speed (turbo) search by pressing **FF** or **REW**.

Slow Motion (S-VHS/VHS Mode Only)

1 ACTIVATE SLOW-MOTION PLAYBACK

During playback or still, turn the **SHUTTLE** ring to the right for forward slow motion, or to the left for reverse slow motion (refer to the illustration on the left).

OR

During still picture, press and hold **PAUSE** for 2 seconds, then release. Press and release again to return to still picture.

OR

During still picture, press and hold **<** or **>**. Release to return to still picture.

To resume normal playback, press **PLAY**.

High-Speed (Turbo) Search

1 ACTIVATE HIGH-SPEED SEARCH

During playback or still, turn the **SHUTTLE** ring all the way to the right for forward high-speed search, or to the left for reverse high-speed search. Releasing **SHUTTLE** resumes still picture playback.

OR

During playback or still, press **FF** for forward high-speed search, or **REW** for reverse high-speed search.

To resume normal playback, press **PLAY**.

NOTES:

- For short searches, press and hold **FF** or **REW** during playback or still picture. When released, normal playback resumes.
- Search in D-VHS mode is not possible with cassettes recorded in D-VHS mode on other D-VHS recorders.

Variable-Speed Search (S-VHS/VHS Mode Only)

1 ACTIVATE VARIABLE-SPEED SEARCH

During playback or still, turn the **SHUTTLE** ring to the right for forward variable-speed search, or to the left for reverse variable-speed search (refer to the illustration above).

To resume normal playback, press **PLAY**.

NOTES:

- The operations using the **JOG** dial or **SHUTTLE** ring are not possible with cassettes recorded in D-VHS mode.
- Refer to the **SHUTTLE** ring illustration above as you read the following procedures.
- If the recorder is left in still or forward slow motion mode for over 5 minutes, it will automatically go into stop mode.
- If the recorder is left in reverse slow motion mode for over 30 seconds, it will automatically go into stop mode.

Still Picture/Frame-By-Frame Playback

1 PAUSE DURING PLAYBACK

Press **PAUSE**.

2 ACTIVATE FRAME-BY-FRAME PLAYBACK (S-VHS/VHS MODE ONLY)

Turn the **JOG** dial to the right for forward frame-by-frame playback, or to the left for reverse frame-by-frame playback.

OR

Press **PAUSE**.

OR

Press **<** or **>**.

To resume normal playback, press **PLAY**.

ATTENTION (S-VHS/VHS Mode Only)

- When normal playback resumes from search, still, slow motion or frame-by-frame playback, the picture may jitter vertically momentarily depending on the type of TV being used.

In the search, still, slow-motion or frame-by-frame playback mode,

- the picture will be distorted.
- the noise bar will appear.
- there may be a loss of colour.

Recording

TV signals being received by the recorder's built-in tuner can be recorded onto a video tape. You can "capture" a TV programme using your video recorder.

- Turn on the TV and select the AV mode.
- Insert a D-VHS cassette to record in the D-VHS mode.

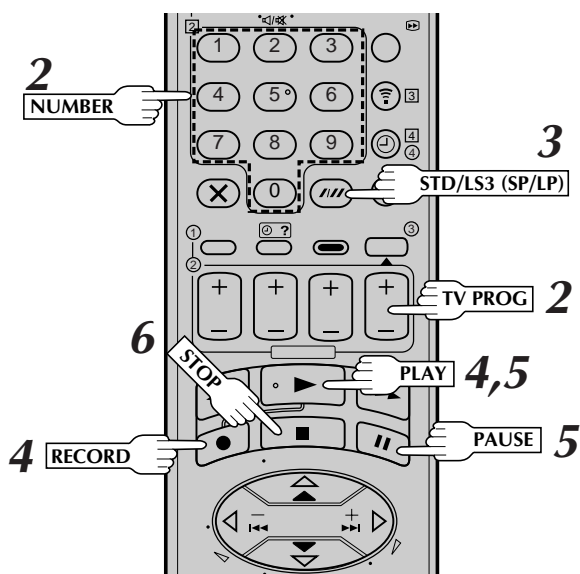
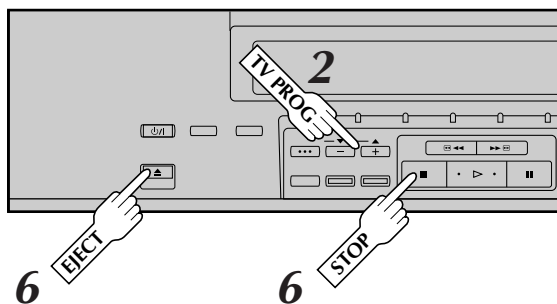
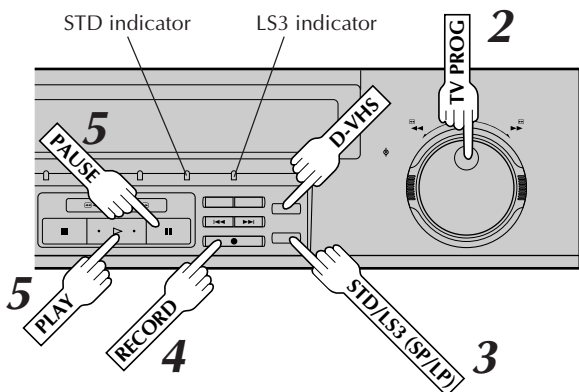

D-VHS Recording

LOAD A CASSETTE

1

Insert a cassette with the record safety tab intact (See next page).

- The counter is reset to 0:00:00 and the recorder power comes on automatically.
- While "----" is blinking on the front display panel, the tape will run for a few seconds to search for the tape number.
- The STD (or LS3) indicator lights and the D-VHS recording mode is selected automatically.

CHOOSE A PROGRAMME

2

Press **TV PROG +/-** or the **NUMBER** keys to select the preset you wish to record.

- The **TV PROG** dial can also be used to select a channel.

SET TAPE SPEED

3

Press **STD/LS3 (///)**. Check the STD or LS3 indicator to confirm the selected tape speed.

START RECORDING

4

Press and hold **RECORD** and press **PLAY** on the remote control, or press **RECORD** on the recorder.

If "DIRECT REC" is set to "ON", the programme that appears on the TV screen will be recorded (☞ pg. 11).

- You can not change the preset whilst recording is in progress. To change the preset, see step 5.

PAUSE/RESUME RECORDING

5

Press **PAUSE**. Press **PLAY** to resume recording.

- During the Record Pause mode, you can change the preset by pressing the **TV PROG +/-** buttons or the **NUMBER** keys.

STOP RECORDING

6

Press **STOP**. Then press **EJECT** to remove the cassette.

NOTE:

To record in the S-VHS or VHS mode on a D-VHS cassette, press **D-VHS** so that the STD (or LS3) indicator goes off (☞ pg. 32).

Compatibility Of Cassettes And Recording Mode

Cassette	Recording Mode		
	D-VHS	S-VHS	VHS
D-VHS	Yes	Yes	Yes
S-VHS	No	Yes	Yes
VHS	No	No	Yes

NOTES:

- The D-VHS (MTP), S-VHS and VHS mode recordings are possible with this recorder.
- To record in the D-VHS mode, use a D-VHS cassette.
- To record in the S-VHS mode, you can use a S-VHS or D-VHS cassette.
- To record in the VHS mode, you can use a VHS, S-VHS or D-VHS cassette.

INFORMATION

When using the AV connection (☞ pg. 6), you can switch between TV mode and AV mode by pressing **TV/VCR**.

* Depending on the type of TV used, **TV/VCR** button does not function as described above.

Accidental erasure prevention

- To prevent accidental recording on a recorded cassette, remove its safety tab. To record on it later, cover the hole with adhesive tape.

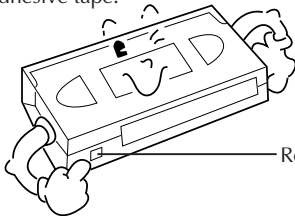

Record safety tab

S-VHS/VHS Recording

LOAD A CASSETTE

Insert a cassette with the record safety tab intact.

- The counter is reset to 0:00:00 and the recorder power comes on automatically.

CHOOSE A PROGRAMME

Press **TV PROG +/-** or the **NUMBER** keys to select the channel you wish to record.

- The **TV PROG** dial can also be used to select a channel.

SET TAPE SPEED

Press **SP/LP (//)**. Check the SP/LP indicator on the front display panel to confirm the selected tape speed.

START RECORDING

Press and hold **RECORD** and press **PLAY** on the remote control, or press **RECORD** on the recorder.

B.E.S.T. takes place at the beginning of both the first SP and the first LP recording after inserting the cassette (☞ pg. 34).

If "DIRECT REC" is set to "ON", the programme that appears on the TV screen will be recorded (☞ pg. 11).

- You can not change the preset whilst recording is in progress. To change the preset, see step 5.

PAUSE/RESUME RECORDING

Press **PAUSE**. Press **PLAY** to resume recording.

- During the Record Pause mode, you can change the preset by pressing the **TV PROG +/-** buttons or the **NUMBER** keys.

STOP RECORDING

Press **STOP**. Then press **EJECT** to remove the cassette.

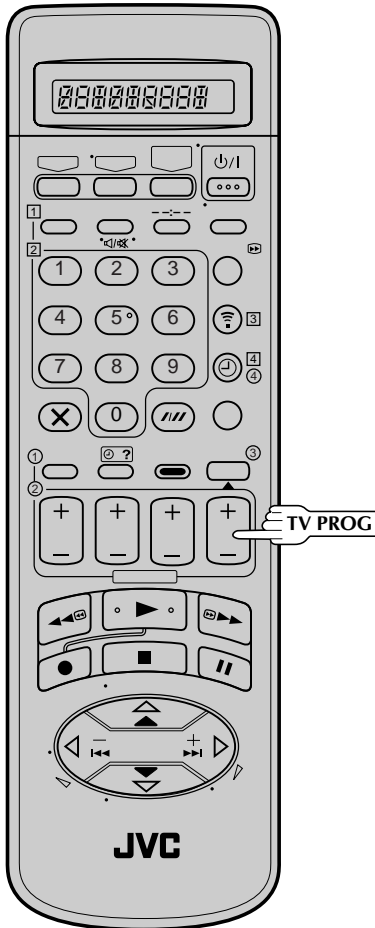
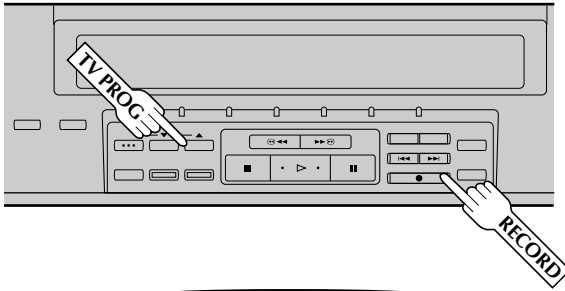

Record One Programme While Watching Another

1 SELECT PRESET TO WATCH

Once recording is in progress, all you need to do is to set the preset controls on the TV for the station you wish to view.

- The programme selected with the TV's preset controls appears on the TV screen while the one selected with the recorder's **TV PROG** buttons is recorded on the tape.

Instant Timer Recording (ITR)

This easy method allows you to record for any length of time from 30 mins. to 8 hours (selectable in 30-min. increments), and shuts off the recorder after recording is finished.

1 START RECORDING

Press **RECORD** on the recorder.

2 ENGAGE ITR MODE

Press **RECORD** again. "ITR" blinks and 0:30 appears on the front display panel.

3 SET RECORDING DURATION

If you want to record for more than 30 minutes, press **RECORD** to extend the time. Each press extends recording time by 30 minutes.

NOTE:

You can only perform ITR using the **RECORD** button on the recorder's front panel.

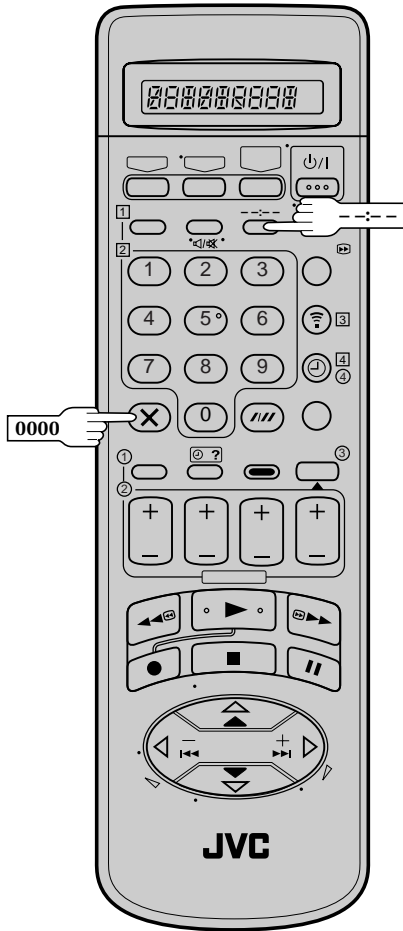
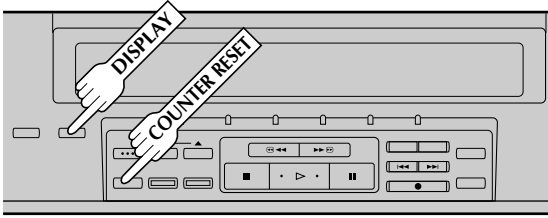

Elapsed Recording Time Indication

You can check the exact time of a recording.

1

SET COUNTER DISPLAY

Press --:-- (or **DISPLAY**) until a counter reading appears on the display panel.

2

RESET COUNTER

Press **0000** (or **COUNTER RESET**) before starting recording or playback.

- The counter is reset to "0:00:00" and shows the exact elapsed time as the tape runs.

Tape Remaining Time

1

DISPLAY REMAINING TIME

Press --:-- (or **DISPLAY**) until the time remaining on the tape appears.

- The display panel shows the tape remaining time with "▶" displayed.
- By pressing the --:-- (or **DISPLAY**) button, you can change the display to show the counter reading, preset position*, clock time or tape remaining time.
*Preset position is not displayed during playback.

NOTE:

Depending on the type of tape used, there may be times when the tape remaining time reading may not appear right away, or is not correct. "--:--" may sometimes appear, or the display may blink on occasion.

VIDEO Plus+[®] Timer Programming

Before performing the VIDEO Plus+ Timer Programming:

- Make sure that the recorder's built-in clock is set properly.
- Insert a cassette with the safety tab in place. The recorder will come on automatically.
- Set the appropriate recording mode (D-VHS, S-VHS or VHS) (see pg. 14, 15).
- Turn on the TV and select the AV mode.

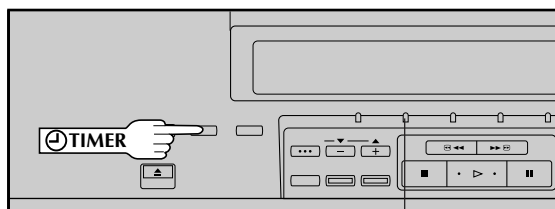

⊕ TIMER indicator

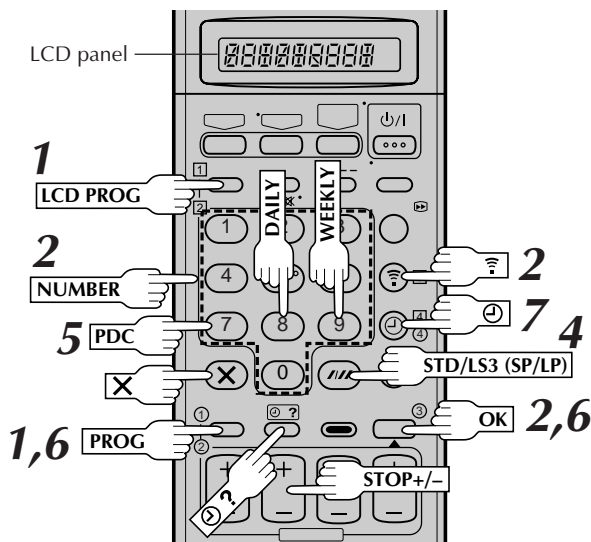

You can use the remote control with LCD panel to enter the PlusCode number.

1

ACCESS VIDEO PLUS+ SCREEN

Press **PROG.**

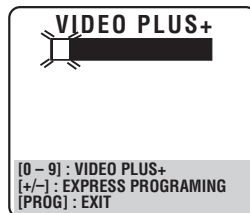

The front display panel looks like this:



2

ENTER PLUSCODE NUMBER

Press the **NUMBER** keys to enter the PlusCode number of the programme you wish to record, then press **OK.**

- If you make a mistake, press **X** and input the correct number.

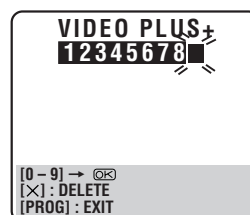

The PlusCode number you enter appears on the front display panel:



The display panel shows only a 4-digit number.

3

ACCESS VIDEO PLUS+ PROGRAM SCREEN

The VIDEO Plus+ Program screen appears (if you're just starting out, "P1" appears).

The display panel shows the programme start time. Pressing **⊕ ?** changes the display to the programme stop time, then the date and preset position.



IMPORTANT

Make sure the preset position number you wish to record is displayed; if not, see "VIDEO Plus+[®] Setup" on page 65 and set the Guide Program number for that PlusCode number correctly.

- If the number you entered is invalid, "ERROR" appears on the screen and "Err" appears on the display panel. Press **X** and input a valid PlusCode number.
- If the "GUIDE PROG SET" screen appears, see "ATTENTION - Regarding Guide Program Number Set" on page 19.

1

ACCESS VIDEO PLUS+ DISPLAY

Press **LCD PROG.**

The LCD panel looks like this:



2

ENTER PLUSCODE NUMBER

Press the **NUMBER** keys to enter the PlusCode number of a programme you wish to record, then press **⊕.**

- If you make a mistake, press **X** and input the correct number.

The PlusCode number you enter appears on the LCD panel:



Then go to step 3 in the right column.

4

SET TAPE SPEED

D-VHS mode:

Press **STD/LS3** (**///**) to set the tape speed.

S-VHS or VHS mode:

Press **SP/LP** (**///**) to set the tape speed.

5

SET PDC MODE

Press **PDC** to select "ON" or "OFF".

If "VPS/PDC ON" is displayed on the screen or "VPS/PDC" is lit on the display panel, PDC is set to ON.

If "VPS/PDC OFF" is displayed on the screen or "VPS/PDC" is not lit on the display panel, PDC is set to OFF.

☞ "PDC Recording" in the column below.

- VPS (Video Programme System) recording is not currently available in the U.K. and not possible with this recorder.

6

RETURN TO NORMAL SCREEN

Press **PROG** or **OK**. "PROGRAM COMPLETED" appears on the screen for about 5 seconds, then normal screen appears.

- Repeat steps 1 – 6 for each additional programme.

7

ENGAGE RECORDER'S TIMER MODE

Press **⊖** (or **⊖TIMER**). The recorder turns off automatically and **⊖** appears on the display panel. The **⊖TIMER** indicator on the recorder also lights up.

- To disengage the timer, press **⊖** (or **⊖TIMER**) again.

NOTES:

- To Change The Stop Time . . .
... press **STOP +/-** in step 3. You can compensate for anticipated programme schedule delays this way.
- To Timer-Record Weekly Or Daily Serials . . .
... in step 3, press **WEEKLY** (**NUMBER** key "9") for weekly serials or **DAILY** (**NUMBER** key "8") for daily serials (Monday – Friday). Either "WEEKLY" or "DAILY" appears on the screen. Pressing the button again makes the corresponding indication disappear.
- You can programme this recorder to timer-record as many as 8 programmes. If you try to programme the recorder to record a ninth, "PROGRAM FULL" appears on screen and "FULL" appears on the front display panel. To record the extra programme, you must first cancel any unnecessary programmes (☞ pg. 22).
- It is not possible to timer-record a TV programme with a PlusCode number which starts with "0".

Satellite Receiver Users

To timer-record a satellite broadcast using the VIDEO Plus+ system:

- 1 Set "AV2 SELECT" to the appropriate mode. (☞ pg. 50)
- 2 Perform steps 1 – 7.
- 3 Set the satellite receiver to the appropriate channel before the selected programme begins.
- 4 Leave the satellite receiver's power on.

ATTENTION

Regarding Guide Program Number Set

"GUIDE PROG SET" appears after performing step 3 if the Guide Program number for the PlusCode number you entered has not been set.

- Press the **NUMBER** keys or **Δ∇** to input the preset position number on which your recorder receives that station, then press **OK** or **▷** to set the Guide Program Number. The VIDEO Plus+ Program screen appears.

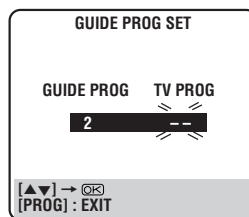

(Ex.) To timer-record a BBC2 programme with the VIDEO Plus+ system.

* If your recorder receives BBC2 on the preset position 2, press **OK** or **▷** after entering "2".

PDC Recording

Now available from some TV stations, PDC (Programme Delivery Control) is a service designed to assure safe, accurate timer recording. With this system, special code signals are transmitted together with the audio/video signals. These code signals control your video recorder and have precedence over the advertised times which you may have preset into the timer. This means that your recorder will start and stop recording when the preset TV programmes actually start and end — even if the broadcast time of a preset TV programme is changed from what has been advertised. PDC is currently available nationally on BBC1, BBC2, Ch.4 and Ch.5, except from a few small relay transmitters. Ch.3 operates a PDC service in some areas. All channels intend to offer this service in due course. Check your TV programme listing guide for latest information. If the channel you intend to record does not offer a PDC service your recorder will not start recording if PDC has been selected. Be sure to set PDC to "OFF" if PDC is not available on your selected channel (☞ step 5 above).

NOTES:

- PDC recording is also possible when a satellite receiver or a cable system is connected to AV2 IN/DECODER on your recorder.
- PDC recording is also possible via the AV1 IN/OUT connector.

Express Timer Programming

Before performing Express Timer Programming:

- Make sure that the recorder's built-in clock is set properly.
- Insert a cassette with the safety tab in place. The recorder will come on automatically.
- Set the appropriate recording mode (D-VHS, S-VHS or VHS) (see pg. 14, 15).
- Turn on the TV and select the AV mode.

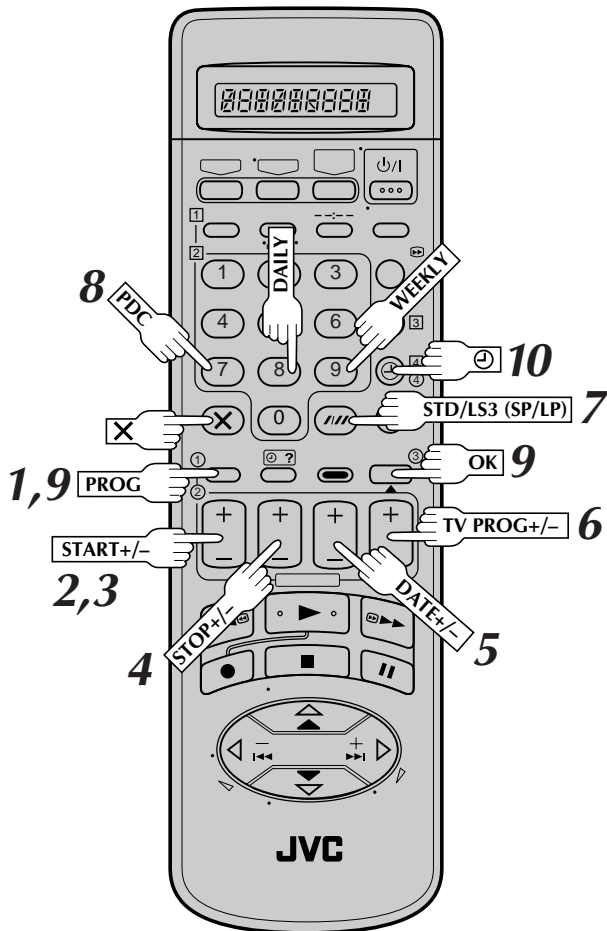

If you don't know the PlusCode number for the programme you wish to record, use the following procedure to set your recorder to timer-record the programme.

1 ACCESS VIDEO PLUS+ SCREEN

Press **PROG**.

2 ACCESS PROGRAMME SCREEN

Press **START +/-**. (If you're just starting out, "P1" appears.)

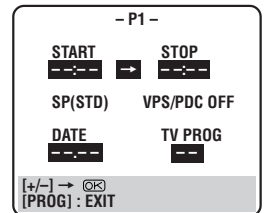

The front display panel looks like this:



3 ENTER PROGRAMME START TIME

Press **START +/-** to enter the time you want recording to start.

- Press and hold **START +/-** to move in 30-minute increments, or press and release repeatedly to move 1 minute at a time.

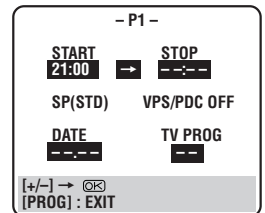

The front display panel looks like this:



4 ENTER PROGRAMME STOP TIME

Press **STOP +/-** to enter the time you want recording to stop.

- Press and hold **STOP +/-** to move in 30-minute increments, or press and release repeatedly to move 1 minute at a time.

5 ENTER PROGRAMME DATE

Press **DATE +/-** to enter the date on which you wish to record. (The current date first appears on screen. The date you enter will appear in its place.)

ENTER PRESET POSITION

6 Press **TV PROG +/-** to enter the preset position corresponding to the broadcasting station you wish to record.

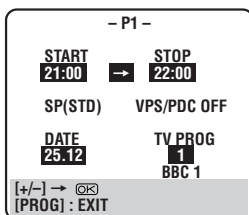

SET TAPE SPEED

D-VHS mode:

Press **STD/LS3 (/ / /)** to set the tape speed.

S-VHS or VHS mode:

Press **SP/LP (/ / /)** to set the tape speed.

SET PDC MODE

Press **PDC** to select "ON" or "OFF".

If "VPS/PDC ON" is displayed on the screen or "VPS/PDC" is lit on the display panel, PDC is set to ON.

If "VPS/PDC OFF" is displayed on the screen or "VPS/PDC" is not lit on the display panel, PDC is set to OFF.

☞ "PDC Recording" in the right column.

- VPS (Video Programme System) recording is not currently available in the U.K. and not possible with this recorder.

RETURN TO NORMAL SCREEN

9 After confirming all information is correct, press **PROG** or **OK**. "PROGRAM COMPLETED" appears on the screen for about 5 seconds, then normal screen appears.

- Repeat steps 1 – 9 for each additional programme.

ENGAGE RECORDER'S TIMER MODE

10 Press **⊖** (or **⊖TIMER**). The recorder turns off automatically and **⊖** appears on the display panel. The **⊖TIMER** indicator on the recorder also lights up.

- To disengage the timer, press **⊕** (or **⊕TIMER**) again.

Satellite Receiver Users

To timer-record a satellite broadcast using Express Timer Programming:

- 1 Set "AV2 SELECT" to the appropriate mode. (☞ pg. 50)
- 2 Perform steps 1 – 10. Select "L-1" or "L-2" for the channel position in step 6, depending on the connection to the satellite tuner (☞ pg. 40).
- 3 Set the satellite receiver to the appropriate channel before the selected programme begins.
- 4 Leave the satellite receiver's power on.

PDC Recording

Now available from some TV stations, PDC (Programme Delivery Control) is a service designed to assure safe, accurate timer recording. With this system, special code signals are transmitted together with the audio/video signals. These code signals control your video recorder and have precedence over the advertised times which you may have preset into the timer. This means that your recorder will start and stop recording when the preset TV programmes actually start and end — even if the broadcast time of a preset TV programme is changed from what has been advertised. PDC is currently available nationally on BBC1, BBC2, Ch.4 and Ch.5, except from a few small relay transmitters. Ch.3 operates a PDC service in some areas. All channels intend to offer this service in due course. Check your TV programme listing guide for latest information. If the channel you intend to record does not offer a PDC service your recorder will not start recording if PDC has been selected. Be sure to set PDC to "OFF" if PDC is not available on your selected channel. (☞ step 8 in the left column).

NOTES:

- Set the start time (PDC time) exactly as advertised in the TV listing. A different time than advertised will result in no recording.
- PDC recording is also possible when a satellite receiver or a cable system is connected to AV2 IN/DECODER on your recorder.
- PDC recording is also possible via the AV1 IN/OUT connector.

To Timer-Record Weekly Or Daily Serials . . .

. . . anytime during steps 2 through 9, press **WEEKLY** (NUMBER key "9") for weekly serials or **DAILY** (NUMBER key "8") for daily serials (Monday – Friday). Either "WEEKLY" or "DAILY" appears on the screen. Pressing the button again makes the corresponding indication disappear.

NOTE:

You can programme this recorder to timer-record as many as 8 programmes. If you try to programme the recorder to record a ninth, "PROGRAM FULL" appears on screen and "FULL" appears on the front display panel. To record the extra programme, you must first cancel any unnecessary programmes (☞ pg. 22).

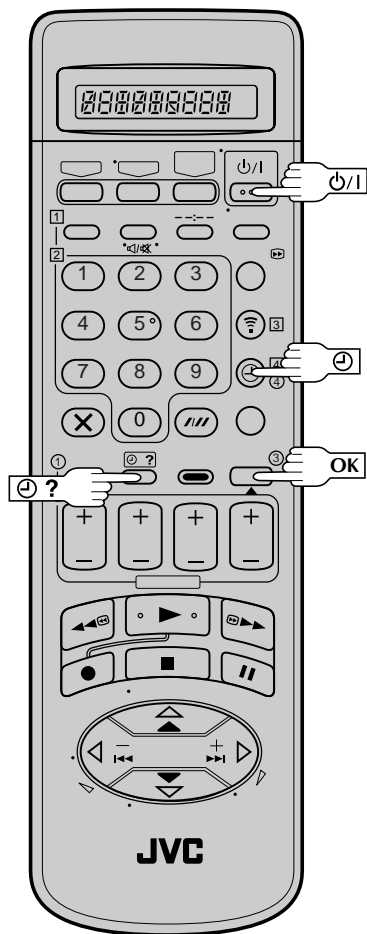

Check, Cancel And Replace Programmes

1 DISENGAGE TIMER MODE

Press **?** (or **TIMER**), then press **⏻/I**.

2 ACCESS PROGRAMME CHECK SCREEN/DISPLAY

Press **?**.

PR	START	STOP	CH	DATE
1	8:00	10:00	3	24.12
2	10:00	10:45	2	25.12
3	11:30	13:00	1	25.12
4				
5				
6				
7				
8				

[?] : NEXT



3 ACCESS PROGRAMME SCREEN/DISPLAY

Press **?** again to check more information. Each time you press **?**, the next programme's information appears.

- P1 -	
START 8:00	STOP 10:00
SP(STD)	VPS/PDC OFF
DATE 24.12	TV PROG 3 ITV

[?] : NEXT



- The display panel shows the programme start time. Pressing **OK** changes the display to the programme stop time, then the date and the preset position.

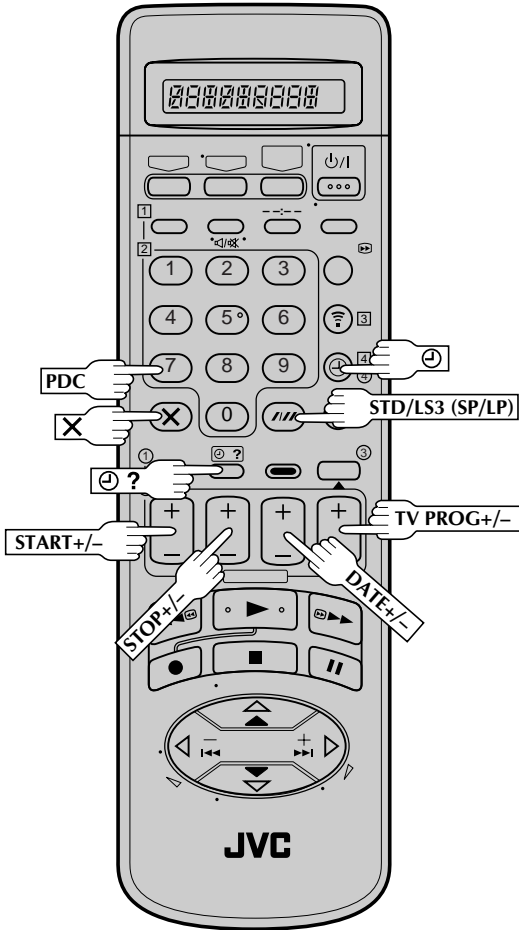

To cancel or replace a programme...

CANCEL OR REPLACE A PROGRAMME

4

Press **X** to cancel a programme. To replace a programme, press the appropriate button: **START+/-**, **STOP+/-**, **DATE+/-**, **TV PROG+/-**, **STD/LS3 (SP/LP)** (**///**), **PDC**.

RETURN TO NORMAL SCREEN/DISPLAY

5

Press **?** as many times as necessary. If there are still some programmes to be recorded, go on to step 6.

RETURN TO TIMER MODE

6

Press **?** (or **?**TIMER).

NOTE:

You can also check the programmes on the display panel even if the recorder's power is off (unless the recorder is in the Power Save mode  pg. 54) or the recorder is in the Timer mode; however, it is not possible to cancel or replace the programmes.

Navigation

Turn on the TV and select the AV mode.

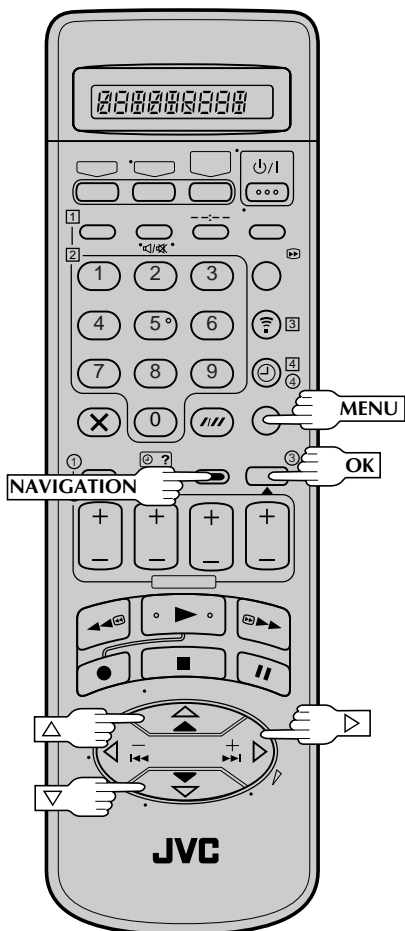
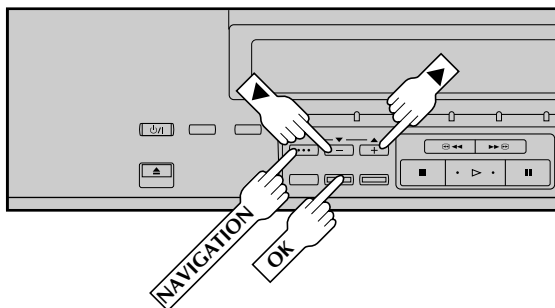

This function is useful when you wish to quickly find out what programmes you have recorded on a tape with this recorder. This function allows you to select a programme to watch, and then automatically searches for the start of the programme.

LOAD A RECORDED CASSETTE

Insert a recorded cassette.

- The tape will run for a few seconds while the recorder searches for the tape number.

ACCESS TITLE SCREEN

Press **NAVIGATION**.

- After pressing **NAVIGATION**, it may take a few seconds to access the title screen while the recorder searches for the programme information.

CHOOSE A PROGRAMME

Press Δ / ∇ (or \blacktriangle / \blacktriangledown) to move the highlight bar (pointer) to the programme you want to watch.

0013	FOOTBALL '98	1/3
	BLANK	1:25 (LS3)
22:00	26.02.99	BBC1
20:00	27.02.99	BBC2
RI	BLANK	0:30 (LS3)
21:00	28.02.99	I-1
22:15	28.02.99	PR.07
21:00	22:30	1:30 (STD)
	WORLD CUP '98	/SPORTS
[Δ / ∇] → [OK]		
[▶]: EDIT		
[NAVIGATION]: EXIT		

START PLAYBACK

Press **OK**. Playback begins automatically after the selected programme is located.

- If you press \triangleright instead of **OK**, the editing screen will appear. You can edit the programme title and category (see pg. 27).

To start recording on the blank portion of a tape

If you do not record programs consecutively, two tape numbers will be recorded on one tape and the recorder will not be able to search for the correct programme. To continue recording on the blank portion of a tape, follow the procedure described below:

- 1 Press Δ / ∇ , and select a "BLANK" item on the program title screen.
- 2 Press **OK**. The recorder automatically searches for a blank portion on the tape.
- 3 After confirming that this is the tape on which you really wish to record, begin recording.

Checking Memory

You can check the amount of recorded information in the memory.

1

ACCESS MAIN MENU SCREEN

Press **MENU**.

2

ACCESS VIDEO NAVIGATION SCREEN

Press $\Delta\nabla$ to move the highlight bar (pointer) to "VIDEO NAVIGATION", then press **OK** or \triangleright .

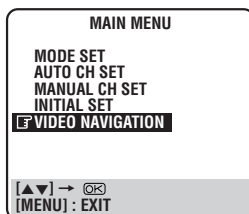

3

CHECK MEMORY

Press $\Delta\nabla$ to move the highlight bar (pointer) to "CHECKING MEMORY", then press **OK** or \triangleright .

- The CHECKING MEMORY screen will appear.

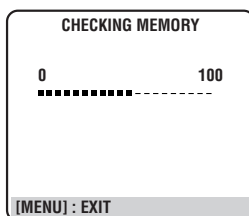
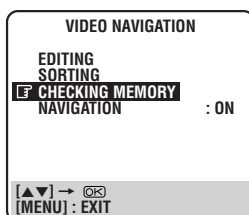

4

RETURN TO NORMAL SCREEN

Press **MENU**.

Turn Off Navigation

If you don't want to record information on the programmes, set "NAVIGATION" to "OFF".

Perform steps 1 to 2 of "Checking Memory" in the left column before continuing.

1

TURN OFF NAVIGATION

Press $\Delta\nabla$ to move the highlight bar (pointer) to "NAVIGATION", then press **OK** or \triangleright to set to "OFF".

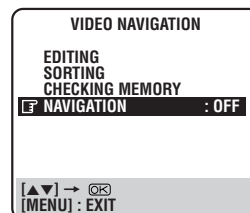

2

RETURN TO NORMAL SCREEN

Press **MENU**.

NOTES:

- Video Navigation is possible with the cassettes recorded with this recorder only.
- To record the date and time as the programme title in this recorder's memory, make sure the recorder's clock is set correctly before recording.
- To record the programme information in this recorder's memory, you must record each programme for over the minimum recording time; 10 min. for the D-VHS (STD) mode, 30 min. for the D-VHS (LS3) mode, 8 min. for the S-VHS/VHS (SP) mode or 15 min. for the S-VHS/VHS (LP) mode.
- Video Navigation may not work properly depending on the cassette being used.
- If the recorder finds two tape numbers in one tape while playing back or searching for the beginning of a programme, then when you remove the tape, the tape will be assigned just one number (smaller number).
- If you overwrite a programme from the beginning, the "☐" symbol is displayed for the title that was overwritten.
- The programme information is stored in this recorder's memory. If the memory in this recorder should ever be damaged and the programme information lost, it is impossible to restore that information.
- After recording a tape with this recorder, write the tape number on a label and affix the label to the cassette in order to allow you to find the tape by its number.

Title Editing

When you record a TV programme with this recorder, the recorder automatically records the recording start time, date, and channel in each programme title. If the tape is recorded for the first time, the tape number and the date and time are recorded in the tape title. You can then edit the tape title and the programme titles as you like. You can also edit the category in the programme title.

In short, you can use the Video Navigation function to create your own video tape library.

Turn on the TV and select the AV mode.

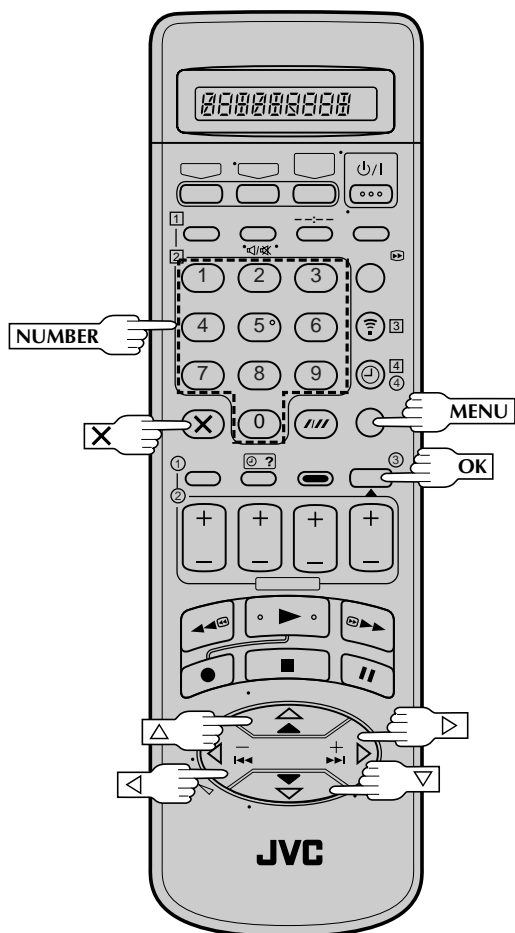

Edit Tape Title

1 ACCESS MAIN MENU SCREEN

Press **MENU**.

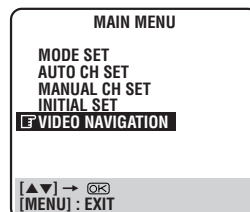

2 ACCESS VIDEO NAVIGATION SCREEN

Press $\Delta\nabla$ to move the highlight bar (pointer) to "VIDEO NAVIGATION", then press **OK** or \triangleright .

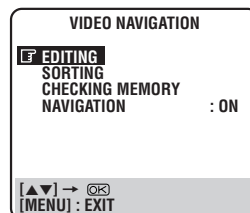

3 ACCESS EDITING SCREEN

Press $\Delta\nabla$ to move the highlight bar (pointer) to "EDITING", then press **OK** or \triangleright .

4 SELECT TAPE NO.

Press $\Delta\nabla$ to move the highlight bar (pointer) to the number of the tape whose title you want to edit, then press **OK** or \triangleright .

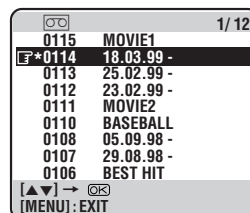

- The "*" mark indicates the tape number of the cassette that is currently in the recorder.

5 SELECT TAPE TITLE

Press $\Delta\nabla$ to move the highlight bar (pointer) to the tape number, then press **OK** or \triangleright .

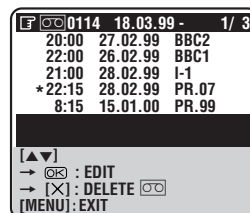

- The "*" mark indicates the current position on the tape.

Edit Programme Title And Category

Perform steps 1 to 4 of "Edit Tape Title" on page 26 before continuing.

1 SELECT PROGRAMME

Press $\Delta \nabla$ to move the highlight bar (pointer) to the programme you want to edit, then press **OK** or \triangleright .

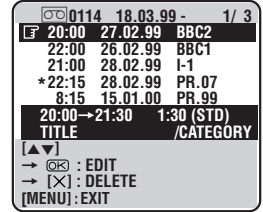

2 ENTER CHARACTER

Press **NUMBER** keys to enter characters, then press **OK**. For details, refer to "Entering Character" in the left column.

3 SELECT CATEGORY

Press $\Delta \nabla$ to move the highlight bar (pointer) to select the category you want, then press **OK** or \triangleright .

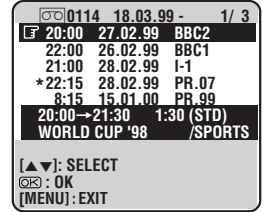

4 RETURN TO NORMAL SCREEN

Press **MENU**.

Choice Of Category

- CATEGORY $\Delta \leftarrow$
- $\Delta \nabla$
- MOVIE
- $\Delta \nabla$
- SPORTS
- $\Delta \nabla$
- SPECIAL
- $\Delta \nabla$
- SERIES
- $\Delta \nabla$
- SHOW
- $\Delta \nabla$
- MUSIC
- $\Delta \nabla$
- CHILDREN
- $\Delta \nabla$
- NEWS
- $\Delta \nabla$
- OTHERS $\nabla \leftarrow$

6 ENTER CHARACTER

Press **NUMBER** keys to enter characters, then press **OK**. For details, refer to "Entering Character" below.

7 RETURN TO NORMAL SCREEN

Press **MENU**.

Entering Character

Press **NUMBER** key, then press \triangleright to enter each character. Refer to the example below.

(Ex.) Enter "JVC NEWS"

- 1 Press 5 (JKL) once to enter "J", then press \triangleright .
- 2 Press 8 (TUV) three times to enter "V", then press \triangleright .
- 3 Press 2 (ABC) three times to enter "C", then press \triangleright .
- 4 Press 0 (space) twice to enter " " (space)", then press \triangleright .
- 5 Press 6 (MNO) twice to enter "N", then press \triangleright .
- 6 Press 3 (DEF) twice to enter "E", then press \triangleright .
- 7 Press 9 (WXYZ) once to enter "W", then press \triangleright .
- 8 Press 7 (PQRS) four times to enter "S", then press \triangleright .

NUMBER KEY	CHARACTER
1	., / - + * () 1
2	A B C 2 Å Ä Å Ä Å Ä Æ
3	D E F 3 È É Ê Ë
4	G H I 4 Î Ï Í
5	J K L 5
6	M N O 6 Ö Ö Ò Ó Õ Ø Ñ
7	P Q R S 7
8	T U V 8 Ü Û Ú Ú
9	W X Y Z 9
0	0 _

NOTES:

- If you make a mistake, press $\triangleleft \triangleright$ to select the character, then enter the correct character.
- If you want to delete a character, press $\triangleleft \triangleright$ to select the character, then press **X**.

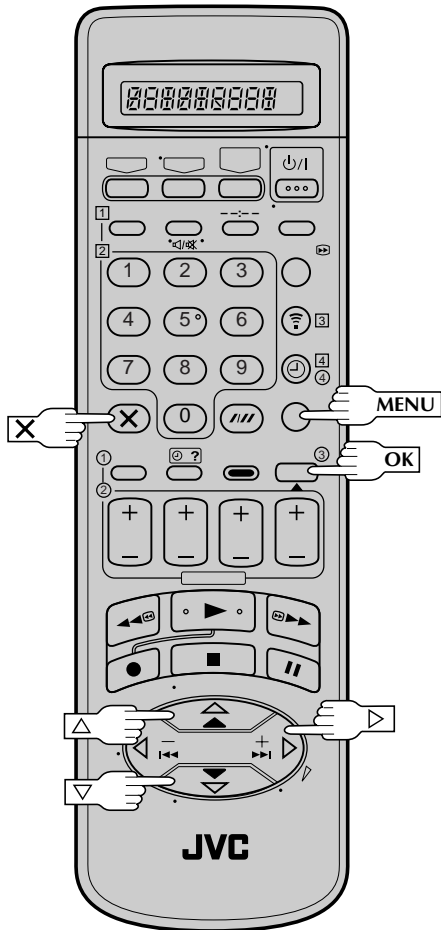

Delete Tape Data

Perform steps 1 to 4 of "Edit Tape Title" on page 26 before continuing.

1

SELECT TAPE TITLE

Press Δ / ∇ to move the highlight bar (pointer) to the tape number you want to delete, then press X.

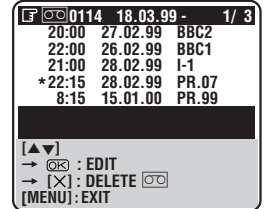

2

DELETE TAPE DATA

Press Δ / ∇ to move the highlight bar (pointer) to "YES", then press OK or \triangleright .

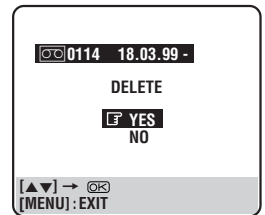

3

RETURN TO NORMAL SCREEN

Press MENU.

Delete Programme Data

Perform steps 1 to 4 of "Edit Tape Title" on page 26 before continuing.

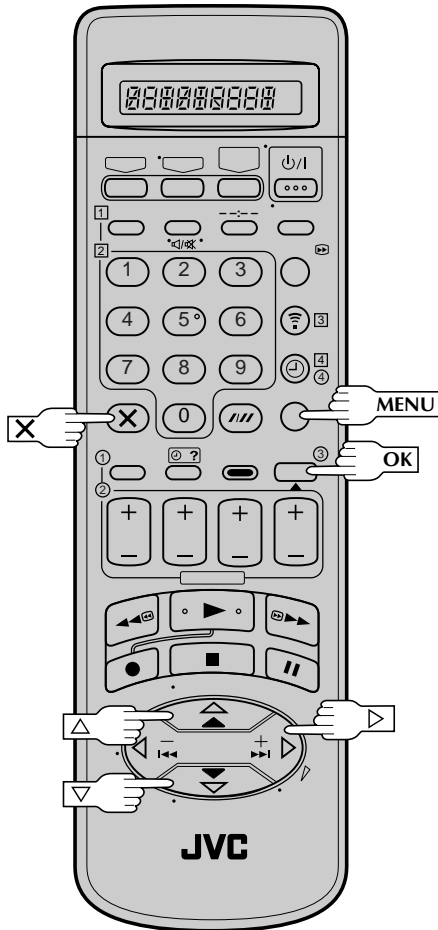

1 SELECT PROGRAMME

Press Δ / ∇ to move the highlight bar (pointer) to the programme you want to delete, then press X.

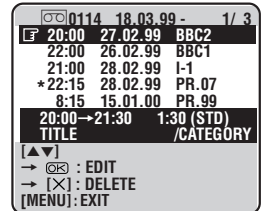

2 DELETE PROGRAMME DATA

Press Δ / ∇ to move the highlight bar (pointer) to "YES", then press OK or \triangleright .

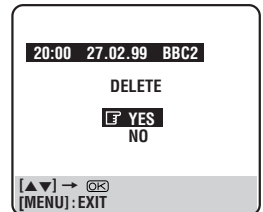

3 RETURN TO NORMAL SCREEN

Press MENU.

NOTES:

- When you delete data, only the tape and/or programme information is deleted. The actual recording on the tape is not erased.
- If the recorder's memory becomes full, the recorder registers the tape in the library under the smallest tape number that is still available.

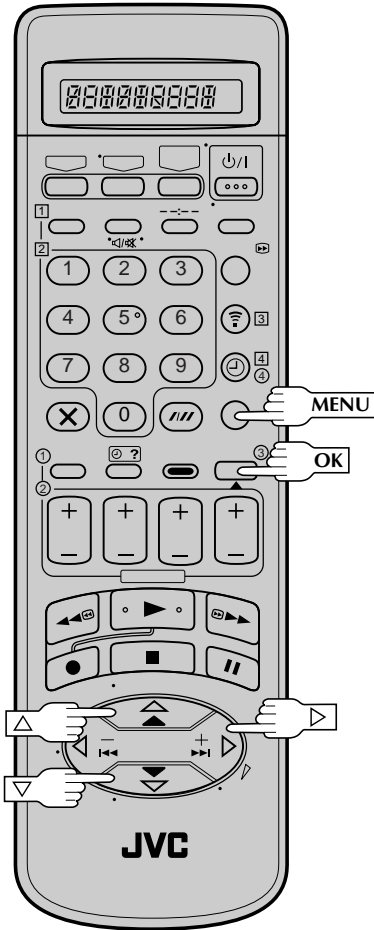

Sorting By Tape Number

If you have recorded a lot of tapes with this recorder, this function is useful for finding out what is recorded on each tape.

- 1** ACCESS MAIN MENU SCREEN

Press **MENU**.
- 2** ACCESS VIDEO NAVIGATION SCREEN

Press $\Delta \nabla$ to move the highlight bar (pointer) to "VIDEO NAVIGATION", then press **OK** or \triangleright .

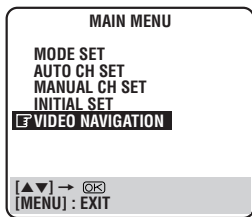

- 3** ACCESS SORTING SCREEN

Press $\Delta \nabla$ to move the highlight bar (pointer) to "SORTING", then press **OK** or \triangleright .

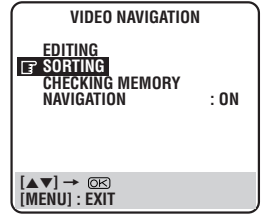

- 4** ACCESS TAPE NO. SCREEN

Press $\Delta \nabla$ to move the highlight bar (pointer) to "BY TAPE NO.", then press **OK** or \triangleright .

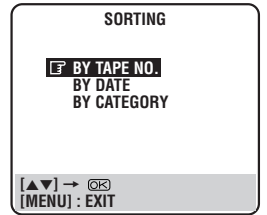

- 5** SELECT TAPE NO.

Press $\Delta \nabla$ to move the highlight bar (pointer) to the tape number you want to select, then press **OK**.

1/100			
0999	BBC2	1900	28.12.99
0999	F1	BRAZIL	28.12.99
0999	007	GOLDE	25.12.99
0999	BBC1	2100	30.11.99
0998	ZDF	2100	28.11.99
0998	PR99	1000	01.01.00
0997	ARSENAL	V	25.11.99
0996	BBC2	2300	24.11.99
0996	RA11	915	26.12.99

- The editing screen will appear. You can edit the tape title, or the programme title and category (see pg. 26, 27).

- 6** RETURN TO NORMAL SCREEN

Press **MENU**.

NOTE:
If you wish to play back the programme on the tape you have found, insert the cassette and see the "Navigation" (see pg. 24) for the operation.

Sorting By Date

If you have recorded a lot of tapes with this recorder, this function is useful for searching for tape numbers sorted by date.

Perform steps 1 to 3 of "Sorting By Tape Number" on page 30 before continuing.

ACCESS DATE SCREEN

- 1** Press $\Delta\nabla$ to move the highlight bar (pointer) to "BY DATE", then press **OK** or \triangleright .

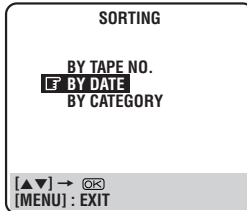

SELECT TAPE NO.

- 2** Press $\Delta\nabla$ to move the highlight bar (pointer) to the tape number you want to select, then press **OK**.

[OK]		1/100
	0997 JAPAN VS	14.02.00
	0993 LOST WORL	02.01.00
[F]	0999 PR99 1000	01.01.00
	0999 FOOTBALL	28.12.99
	0999 F1 BRAZIL	28.12.99
	0996 RA11 2000	26.12.99
	0999 007 GOLDE	25.12.99
	0993 CNN 115	25.12.99
	0999 BBC1 2000	30.11.99
[◀▶]: PAGE	[MENU]: EXIT	
[▲▼] → [OK]	: EDIT	

- The editing screen will appear. You can edit the tape title, or the programme title and category (☞ pg. 26, 27).

RETURN TO NORMAL SCREEN

Press **MENU**.

Sorting By Category

If you have recorded a lot of tapes with this recorder, this function is useful for finding out what category of programme is recorded on the tape.

Perform steps 1 to 3 of "Sorting By Tape Number" on page 30 before continuing.

ACCESS CATEGORY SCREEN

- 1** Press $\Delta\nabla$ to move the highlight bar (pointer) to "BY CATEGORY", then press **OK** or \triangleright .

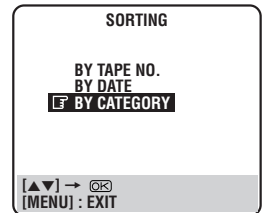

SELECT CATEGORY

- 2** Press $\Delta\nabla$ to move the highlight bar (pointer) to the category you want to watch, then press **OK** or \triangleright .

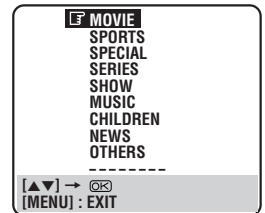

SELECT TAPE NO.

- 3** Press $\Delta\nabla$ to move the highlight bar (pointer) to the tape number you want to select, then press **OK**.

[OK]	MOVIE	1/ 2
	0999 007 GOLDE	25.12.99
	0980 GUNDAM3	23.12.98
	0979 GUNDAM2	21.12.98
	0975 GUNDAM1	30.10.99
	0960 ZDF 2100	28.11.97
[F]	0960 PR99 1000	01.01.00
	0951 GODILLA	25.11.97
	0926 CNN 115	06.06.98
	0910 RA11 930	05.02.99
[◀▶]: PAGE	[MENU]: EXIT	
[▲▼] → [OK]	: EDIT	

- The editing screen will appear. You can edit the tape title, or the programme title and category (☞ pg. 26, 27).

RETURN TO NORMAL SCREEN

Press **MENU**.

Recording According To Tape Type

Turn on the TV and select the AV mode.

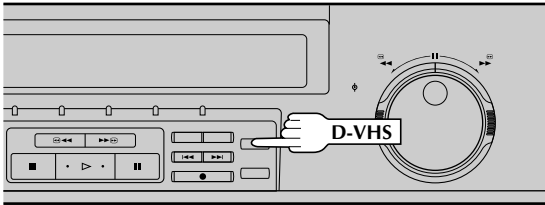

S-VHS (Super VHS) And VHS

Your recorder can also record in either S-VHS or VHS.

To record in S-VHS on a D-VHS cassette:

Perform the steps **1 – 4** to set "S-VHS" to "AUTO". Then, insert a cassette marked "D-VHS" and press **D-VHS** to turn off the D-VHS mode. The STD (or LS3) indicator will go off and the S-VHS indicator on the front display panel will light. The S-VHS recording mode will be selected.

To record in VHS on a D-VHS cassette:

Insert a cassette marked "D-VHS" and press **D-VHS** to turn off the D-VHS mode. The STD (or LS3) indicator will go off and the S-VHS indicator on the front display panel will light. Then, perform the steps **1 – 4** to set the "S-VHS" to "OFF"; the S-VHS indicator will go off. The VHS recording mode will be selected.

To record in S-VHS on an S-VHS cassette:

Perform the steps **1 – 4** to set "S-VHS" to "AUTO". Then, insert a cassette marked "S-VHS". The S-VHS indicator on the front display panel will light. The S-VHS recording mode will be selected.

To record in VHS on an S-VHS cassette:

Insert a cassette marked "S-VHS". The S-VHS indicator on the front display panel will light. Then, perform the steps **1 – 4** to set the "S-VHS" to "OFF"; the S-VHS indicator will go off. The VHS recording mode will be selected.

To record in VHS on a VHS cassette:

Insert a cassette marked "VHS". The VHS recording mode will be automatically selected regardless of the S-VHS mode setting.

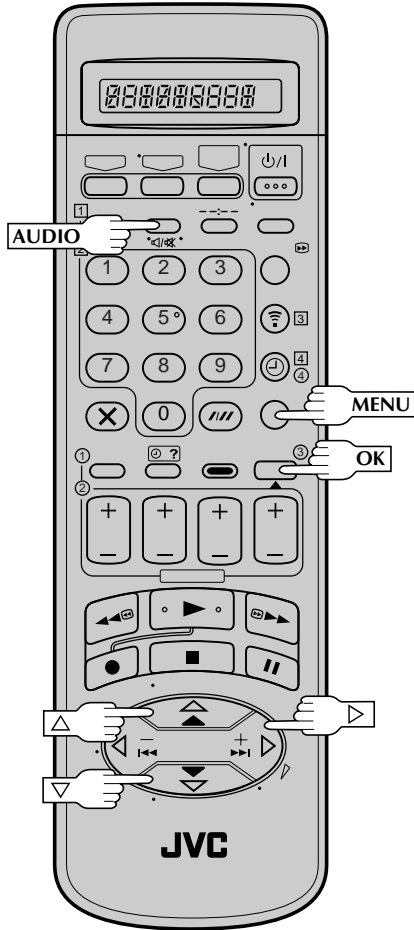

1 ACCESS MAIN MENU SCREEN

Press **MENU**.

2 ACCESS MODE SET SCREEN

Move the highlight bar (pointer) to "MODE SET" by pressing Δ ∇ , then press **OK** or \triangleright .

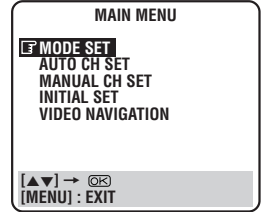

3 SELECT S-VHS MODE

Move the highlight (pointer) to "S-VHS" by pressing Δ ∇ , then press **OK** or \triangleright to select "AUTO" or "OFF".

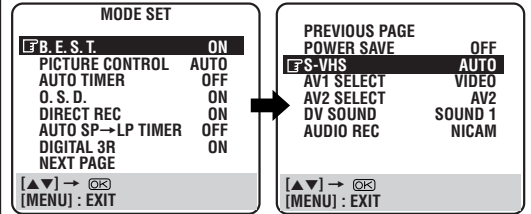

4 RETURN TO NORMAL SCREEN

Press **MENU**.

NOTE:

When playing back a tape that has been recorded in S-VHS, the S-VHS indicator lights on the display panel regardless of the "S-VHS" mode setting.

Playback/ Recording According To Tape Charac- teristics (S-VHS/ VHS Mode Only)

Turn on the TV and select the AV mode.

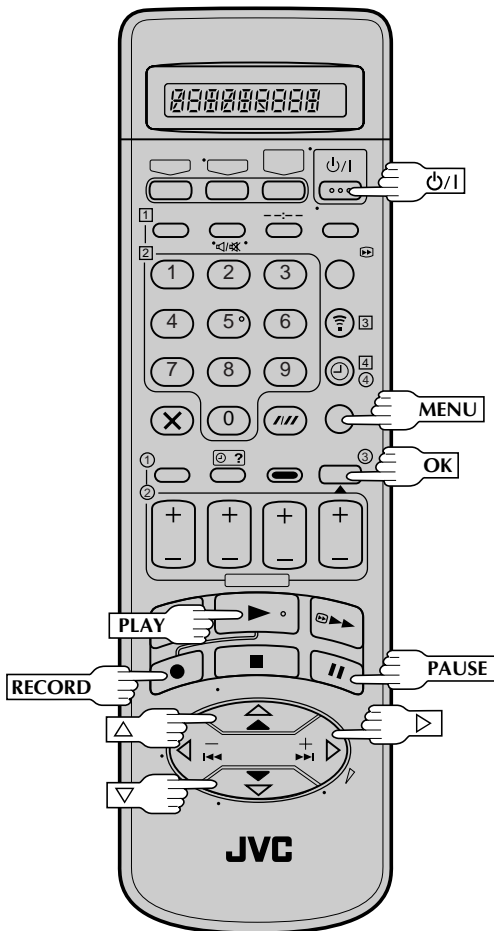

The **power**, **PLAY**, **RECORD**, and **PAUSE** buttons on the recorder have the same function as those on the remote control.

B.E.S.T. Picture System

The B.E.S.T. (Biconditional Equalised Signal Tracking) system checks the condition of the tape in use during recording and playback, and compensates to provide the highest-possible recording and playback pictures. The default setting for both recording and playback is "ON".

1 TURN ON THE RECORDER

Press **power**.

2 ACCESS MAIN MENU SCREEN

Press **MENU**.

3 ACCESS MODE SET SCREEN

Press **up/down** to move the highlight bar (pointer) to "MODE SET", then press **OK** or **right**.

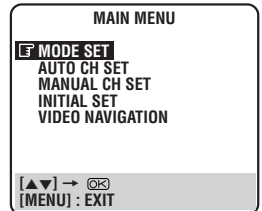

4 SELECT B.E.S.T. MODE

Press **up/down** to move the highlight bar (pointer) to "B.E.S.T.", then press **OK** or **right** to set to "ON" or "OFF".

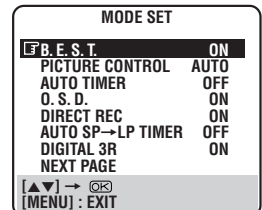

5 RETURN TO NORMAL SCREEN

Press **MENU**.

Recording

1

START RECORDING

Press and hold **RECORD** and press **PLAY** on the remote, or press **RECORD** on the recorder.

DURING B.E.S.T.



B.E.S.T. COMPLETE



- The recorder spends approximately 7 seconds assessing the condition of the tape, then begins recording.

NOTES:

- The B.E.S.T. system works for both SP and LP modes only after a tape has been inserted and the Record mode is first initiated. It does not work during recording.
- The B.E.S.T. system does not work while Auto Satellite Prog recording is in progress (☞ pg. 40).
- In the case of timer recording, the B.E.S.T. system works before recording is initiated.
- Once the cassette is ejected, the B.E.S.T. data is cancelled. The next time the cassette is used for recording, B.E.S.T. is re-performed.
- Pressing the recorder's **RECORD** button while "BEST" is displayed does not start Instant Timer Recording (☞ pg. 16).

ATTENTION

Since the B.E.S.T. system works before recording actually starts, there is a delay of approximately 7 seconds after **RECORD** and **PLAY** on the remote are pressed, or **RECORD** on the recorder is pressed. To make sure you record the desired scene or programme in its entirety, first perform the following steps:

- 1) Press and hold **PAUSE** and press **RECORD** to engage the **RECORD PAUSE** mode.
 - The recorder then automatically checks the condition of the tape and, after approximately 7 seconds, re-enters **RECORD PAUSE**.
- 2) Press **PLAY** when you are ready to start recording.
 - If you want to bypass the B.E.S.T. system and begin recording immediately, set "B.E.S.T." to "OFF" in step 4 on page 34.

Playback

The recorder assesses the quality of the tape once you initiate playback.

1

START PLAYBACK

Press **PLAY**.



- The recorder adjusts the playback picture quality based on the quality of the tape in use.
- B.E.S.T. is active during Auto Tracking. "BEST" appears blinking on the recorder's display panel.

NOTES:

- When watching a tape recorded with "B.E.S.T." set to "ON", it is recommended that you leave B.E.S.T. on during playback as well.
- When watching a rental tape or one recorded on another video recorder, or when using this recorder as the player for editing, set B.E.S.T. to your preference by performing steps 1 through 5 on page 34.
- "BEST" only appears at the beginning of automatic tracking. Even though it doesn't appear after that, the B.E.S.T. function is operative.

Playback Picture Adjustment

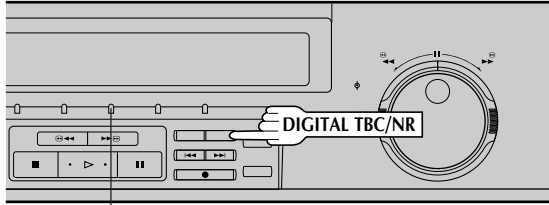

DIGITAL TBC/NR indicator

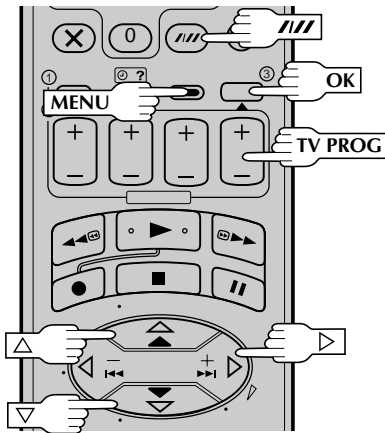

Manual Tracking

Your video recorder is equipped with automatic tracking control. For most tapes this will automatically adjust the tracking to suit the particular tape you are playing. In some circumstances it may be necessary to make manual tracking adjustments. This is usually only associated with old or worn tapes or recordings made on old or worn recorders. If the automatic tracking control fails to operate correctly you will see noise bars across the picture as shown on the left below. To correct this you can override the automatic control and adjust the tracking manually by pressing the **TV PROG** buttons.

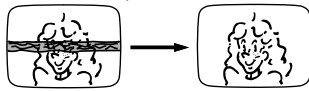

1 **OVERRIDE AUTOMATIC TRACKING**
Press **///** on the remote to engage manual tracking.

2 **ADJUST TRACKING MANUALLY**
Press **TV PROG** + or - to adjust tracking.

3 **RETURN TO AUTOMATIC TRACKING**
Press **///** on the remote to re-engage automatic tracking.

NOTE:

When a new tape is inserted, the recorder returns to the automatic tracking mode automatically.

Digital TBC/NR (S-VHS/VHS Mode Only)

Your video recorder is equipped with the Digital TBC (Time Base Corrector) that removes jitter from fluctuating video signals to deliver a stable picture even with old tapes and rental cassettes.

The on/off of Digital 3-DNR (Noise Reduction) which cuts noise and enables clear picture reproduction is also linked to this function.

* The default setting is "ON".

We recommend that you use the Digital TBC feature when...
... playing back a tape recorded on a camcorder.
... playing back a tape repeatedly used.
... using this video recorder as the player for editing.

1 ACTIVATE DIGITAL TBC/NR

Press **DIGITAL TBC/NR** so that the DIGITAL TBC/NR indicator lights up.

- To turn off DIGITAL TBC/NR, press **DIGITAL TBC/NR** again so that the indicator goes off.

NOTES:

- If you play back a tape recorded under poor TV reception condition, there may be cases where the picture becomes more stable with Digital TBC/NR set to off.
- When Digital TBC/NR is set to on, if you play back a tape where certain types of signals are recorded (using a PC or some character generators), the playback picture may be distorted. If this is the case, turn off Digital TBC/NR.

Digital 3R (S-VHS/VHS Mode Only)

Digital 3R picture system applies edge correction to the luminance and chrominance signals to enhance detail.

1 **ACCESS MAIN MENU SCREEN**
Press **MENU**.

2 **ACCESS MODE SET SCREEN**
Move the highlight bar (arrow) to "MODE SET" by pressing **△▽**, then press **OK** or **▷**.

3 **SELECT DIGITAL 3R SET MODE**
Move the highlight bar (arrow) to "DIGITAL 3R" by pressing **△▽**, then press **OK** or **▷** to set to "ON".

MODE SET	
B. E. S. T.	ON
PICTURE CONTROL	AUTO
AUTO TIMER	OFF
O. S. D.	ON
DIRECT REC	ON
AUTO SP → LP TIMER	OFF
DIGITAL 3R	ON
NEXT PAGE	
[▲▼] → [OK] [MENU] : EXIT	

4 **RETURN TO NORMAL SCREEN**
Press **MENU**.

NOTES:

- Normally it is recommendable to keep "DIGITAL 3R" set to "ON".
- Depending on the type of tape being used, picture quality may sometimes be better with "DIGITAL 3R" set to "OFF".

Looking For The Scene You Want

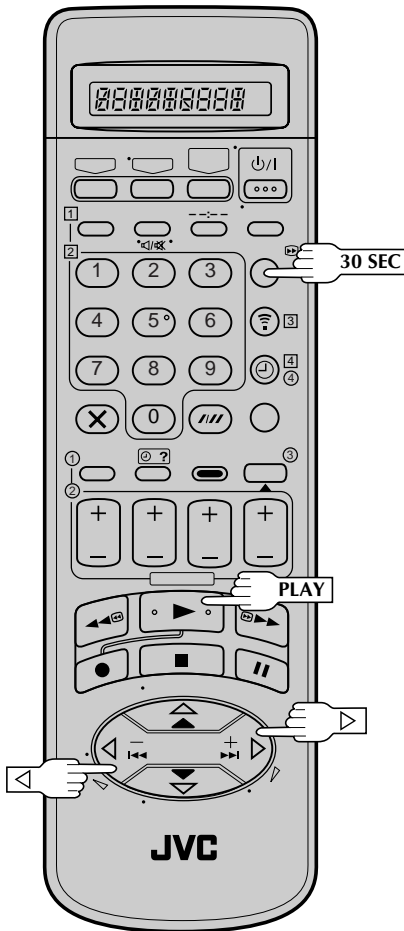

Index Search

Your recorder automatically marks index codes at the beginning of each recording. This function gives you quick access to any one of 9 index codes in either direction.

NOTE:

Before starting, make sure the recorder is in the Stop mode.

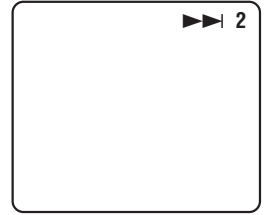

1 ACTIVATE INDEX SEARCH

Press < or > (◀◀ or ▶▶). “◀◀ 1” or “▶▶ 1” is displayed on screen and search begins in the corresponding direction.

- To access index codes 2 through 9, press < or > repeatedly until the correct index number is displayed.
Ex.: To locate the beginning of B from the current position, press < twice.
To locate the beginning of D from the current position, press > once.

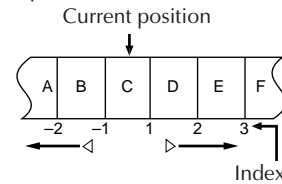

- When the specified index code is located, playback begins automatically.

Skip Search

1 SKIP OVER UNWANTED SECTIONS

Press **30 SEC** 1 to 4 times during playback. Each press initiates a 30-second period of fast-motion playback. Normal playback resumes automatically.

NOTE:

To return to normal playback during a Skip Search, press **PLAY**.

Selecting The Sound You Want

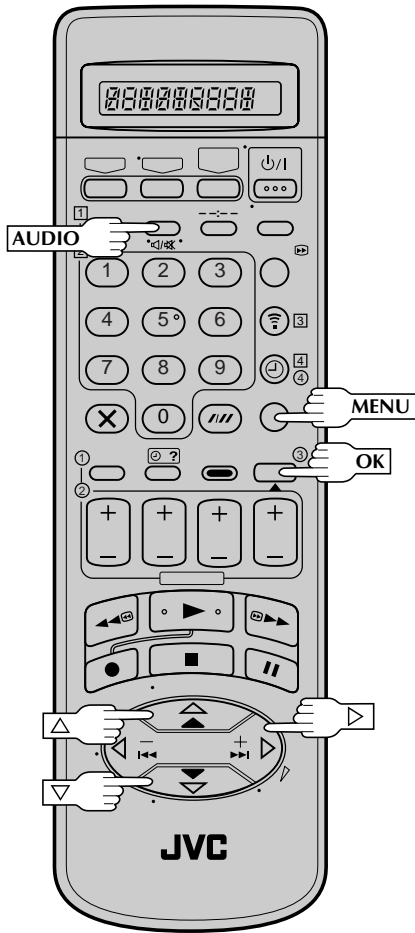

Receiving NICAM Stereo And Bilingual Programmes

Your recorder is equipped with a Digital stereo sound decoder (NICAM), making reception of stereo and bilingual broadcasts possible.

When the recorder is tuned to a different station, the type of broadcast being received will be displayed on the TV screen for a few seconds.

Type of Broadcast Being Received	On-screen Display
Regular Monaural	(none)
NICAM Stereo	ST NICAM
NICAM Bilingual	BIL NICAM
NICAM Monaural	NICAM

- To listen to a stereo programme, press **AUDIO** until "L [] R" and "[]" appear on the front display panel or "L [] R" appears on the screen.
- To listen to a bilingual programme, press **AUDIO** until either "[]" or "[]" appears on the front display panel or "L []" or "[] R" appears on the screen (as required).
- **S-VHS/VHS mode**
To listen to the Standard (regular monaural) audio while receiving a NICAM broadcast, press **AUDIO** until "NORM" appears on the front display panel or on the screen.

NOTES:

- The NICAM audio programme will be recorded on the Hi-Fi audio track, and the Standard audio programme on the normal audio track.
- If the quality of stereo sound being received is poor, the broadcast will be received in monaural with better quality.
- Before playing back a programme recorded in stereo, or a bilingual programme, refer to "Soundtrack Selection" (See page 39).
- "O.S.D." must be set to "ON" or the on-screen displays will not appear (☞ pg. 53).

To Record NICAM Stereo And Bilingual Programmes (Only For The Users In Eastern Europe)

- **S-VHS/VHS mode**
The NICAM audio programme will be recorded on the Hi-Fi audio track, and the Standard audio programme on the normal audio track.
- **D-VHS mode** (See "Audio Rec Mode Setting" on page 39.)

NOTES:

- If the quality of stereo sound being received is poor, the broadcast will be received in monaural with better quality.
- Before playing back a programme recorded in stereo, or a bilingual programme, refer to "Soundtrack Selection" (☞ pg. 39).

Soundtrack Selection (S-VHS/VHS Mode)

Your video recorder is capable of recording three soundtracks (Hi-Fi L, Hi-Fi R and NORM) in the S-VHS/VHS mode and will play back the one you select.

During Playback

Pressing **AUDIO** on the remote control changes the soundtrack being played back as follows:

TRACK		USE
Recorder's Front Panel	On-Screen Display	
	L R	For Hi-Fi stereo tapes
	L	For main audio of Bilingual tapes
	R	For sub audio of Bilingual tapes
NORM	NORM	For audio-dubbed tapes
	L R NORM	For audio-dubbed tapes

NOTES:

- " + " should normally be selected. In this mode, Hi-Fi stereo tapes are played back in stereo, and the normal audio track is played back automatically for tapes with only normal audio.
- For instructions on recording NICAM stereo and bilingual programmes, see page 38.
- Bilingual programmes are not currently broadcast in the U.K.
- "O.S.D." must be set to "ON" or the on-screen displays will not appear (pg. 53).

Soundtrack Selection (D-VHS Mode)

Your video recorder is capable of recording two soundtracks (L and R) in the D-VHS mode and will play back the one you select.

During Playback

Pressing **AUDIO** on the remote control changes the soundtrack being played back as follows:

TRACK		USE
Recorder's Front Panel	On-Screen Display	
	L R	For stereo tapes
	L	For main audio of Bilingual tapes
	R	For sub audio of Bilingual tapes

Audio Rec Mode Setting (D-VHS Mode Only)

- 1 Press **MENU** to access the Main Menu screen.
- 2 Move the highlight bar (pointer) to "MODE SET" by pressing $\Delta \nabla$, then press **OK** or \triangleright .
- 3 Move the highlight bar (pointer) to "AUDIO REC" by pressing $\Delta \nabla$, then press **OK** or \triangleright to select "NICAM" or "MONO".
- 4 Press **MENU** to return to the normal screen.

- When "AUDIO REC" is set to "NICAM", the NICAM audio programme will be recorded on the audio track.
- When "AUDIO REC" is set to "MONO", the Standard (monaural) audio program will be recorded on the audio track.

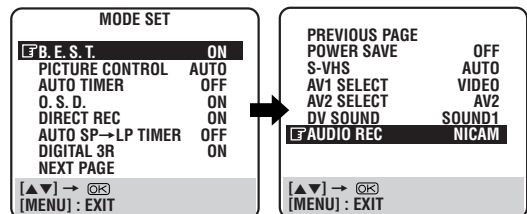

Automatic Satellite Programme Recording

This facility allows you to record automatically a satellite programme which is timer-programmed on your external satellite receiver. Connect a satellite receiver to the recorder's AV2 IN/DECODER connector and programme the timer on the satellite receiver; the recorder starts recording when the signals input from the satellite receiver to the AV2 IN/DECODER connector, and when there is no input signals the recorder stops recording and the power shuts off.

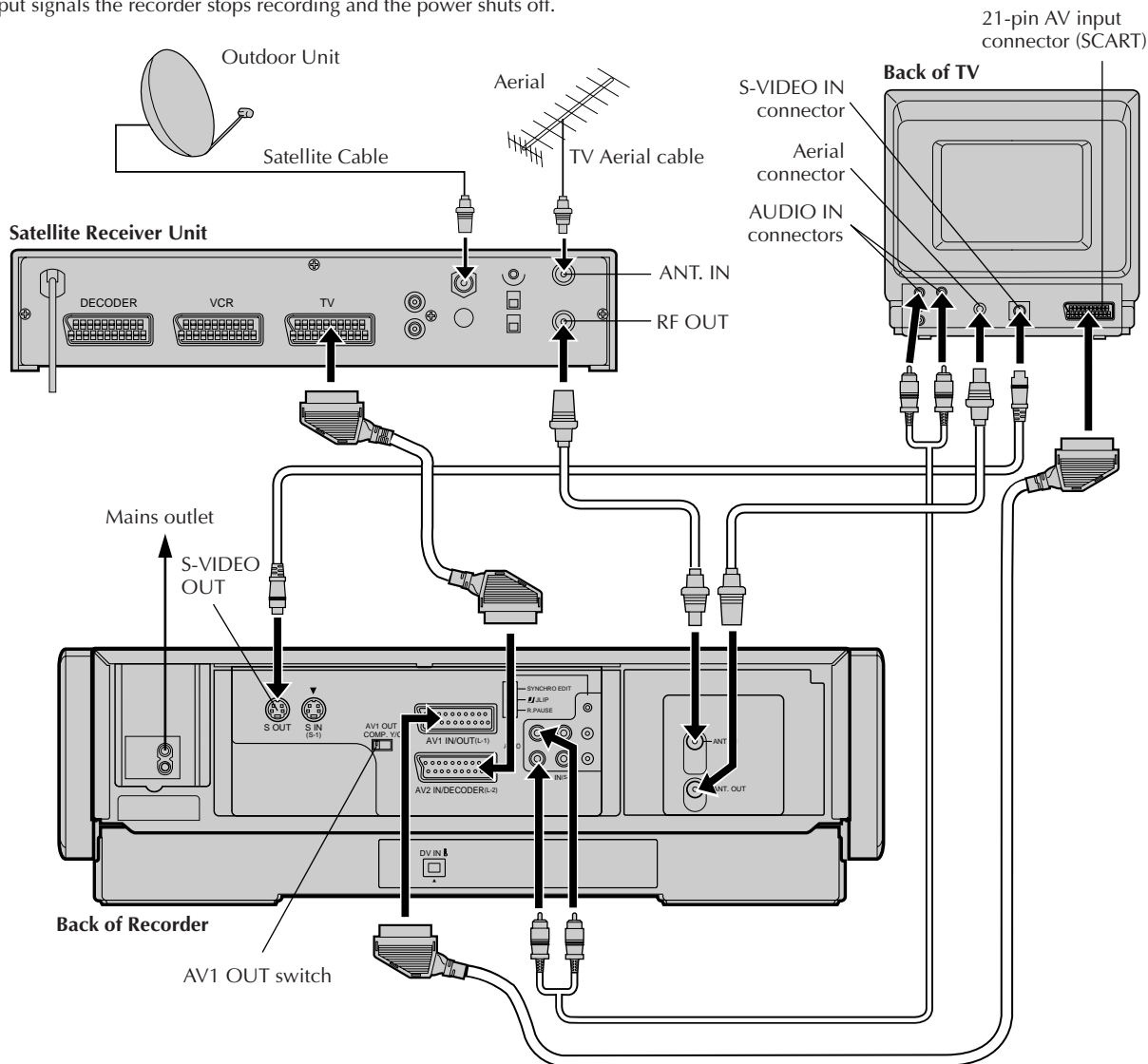

IMPORTANT

When you set "AV2 SELECT" to "SAT" (pg. 50), it is possible to view a satellite broadcast with the TV set to its AV mode even if the recorder is in Timer mode, in Stop mode, recording or turned off. When the recorder is in Stop mode or recording, press **TV/VCR** on the remote control to turn off the VCR indicator on the display panel.

- In this case, be sure to set the **AV1 OUT** switch on the rear panel to **COMP**.

NOTES:

- Set the satellite receiver's output mode to Composite.
- Refer to the instructions supplied with your satellite receiver.

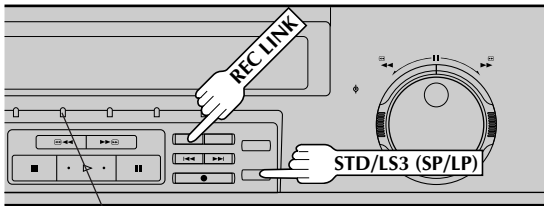

REC LINK indicator

ATTENTION

- Be sure not to turn on the satellite receiver before the programme is executed; otherwise, the recorder will start recording when the satellite receiver's power is turned on.
- If you have connected another appliance other than a satellite receiver to the AV2 IN/DECODER connector, be sure not to engage the Auto Satellite Prog Rec mode; otherwise, the recorder will start recording when the connected appliance's power is turned on.
- Auto Satellite Prog recording and timer-recording cannot be done at the same time.
- When you press and hold the recorder's **REC LINK** button to engage the Auto Satellite Prog Rec mode, if the REC LINK indicator does not light but instead blinks quickly even though your satellite receiver's power is off, Auto Satellite Prog Recording will not work properly with that satellite receiver*.

If this is the case, perform "Express Timer Programming" (☞ pg. 20) to timer-record a satellite programme.

*Some satellite receivers output signals even if the power is off.
Auto Satellite Prog Recording is not possible with those satellite receivers.

Before performing the following steps:

- Make sure the satellite receiver is connected to the recorder's AV2 IN/DECODER connector. (☞ pg. 40)
- Programme the timer on the satellite receiver.
- Insert a cassette with the safety tab in place.
- Set the appropriate recording mode (D-VHS, S-VHS or VHS) (☞ pg. 14, 15).

1 ACCESS MAIN MENU SCREEN

Press **MENU**.

2 ACCESS MODE SET SCREEN

Move the highlight bar (pointer) to "MODE SET" by pressing Δ ∇ , then press **OK** or \triangleright .

3 SELECT AV2 SELECT MODE

Move the highlight bar (pointer) to "AV2 SELECT", by pressing Δ ∇ , then press **OK** or \triangleright to set to "SAT".

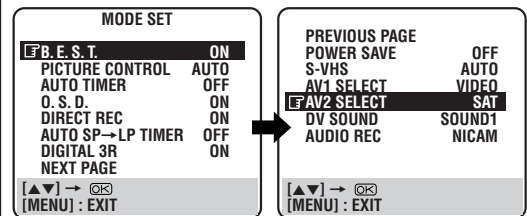

4 SET TAPE SPEED

D-VHS mode:

Press **STD/LS3** (///) to set the tape speed.

S-VHS or VHS mode:

Press **SP/LP** (///) to set the tape speed.

5 ENGAGE AUTO SATELLITE PROG REC MODE

Press and hold **REC LINK** for about 2 seconds. The REC LINK indicator lights up and the recorder turns off automatically.

- To disengage the Auto Satellite Prog Rec mode, press **REC LINK**. The REC LINK indicator goes off.
- If the recorder's power is off, it is not possible to engage the Auto Satellite Prog Rec mode.

NOTES:

- Auto Satellite Prog recording is possible with the AV2 IN/DECODER connector only.
- When the Auto Satellite Prog Rec mode is engaged or the recorder's power is turned off after Auto Satellite Prog recording is finished, the recorder will not enter the Timer mode even though "AUTO TIMER" is set to "ON".
- For timer programming of the satellite receiver, refer to the instruction manual of the satellite receiver.
- Auto Satellite Prog recording is not possible if your satellite receiver does not have a timer.
- The REC LINK indicator blinks while Auto Satellite Prog recording is in progress.
- Pressing the recorder's O/I button while Auto Satellite Prog recording is in progress turns off the recorder's power and disengages the Auto Satellite Prog Rec mode.
- If there is more than one satellite programme you wish to record with Auto Satellite Prog Recording, it is not possible to set a different tape speed for each; the tape speed selected in step 4 will apply to all the programmes for Auto Satellite Prog recording.
- The B.E.S.T. system (☞ pg. 34) does not work while Auto Satellite Prog recording is in progress.
- Just Clock (☞ pg. 66) does not work when the Auto Satellite Prog Rec mode is engaged.
- Depending on the type of satellite receiver, the recorder may not record a short portion at the beginning of the programme or may record slightly longer than the actual length of the programme.
- If you engage the Auto Satellite Prog Rec mode when the satellite receiver's power is on, the recorder will not start Auto Satellite Prog recording even though the REC LINK indicator blinks. When the satellite receiver shuts off once and is turned back on again, the recorder starts recording.
- You can also record a programme from your cable system in the same way if the system has a timer and is connected to the recorder's AV2 IN/DECODER connector.

Remote Control Functions

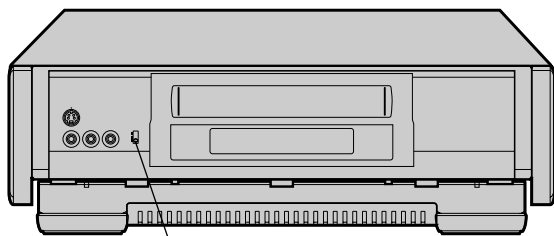

Remote control code switch

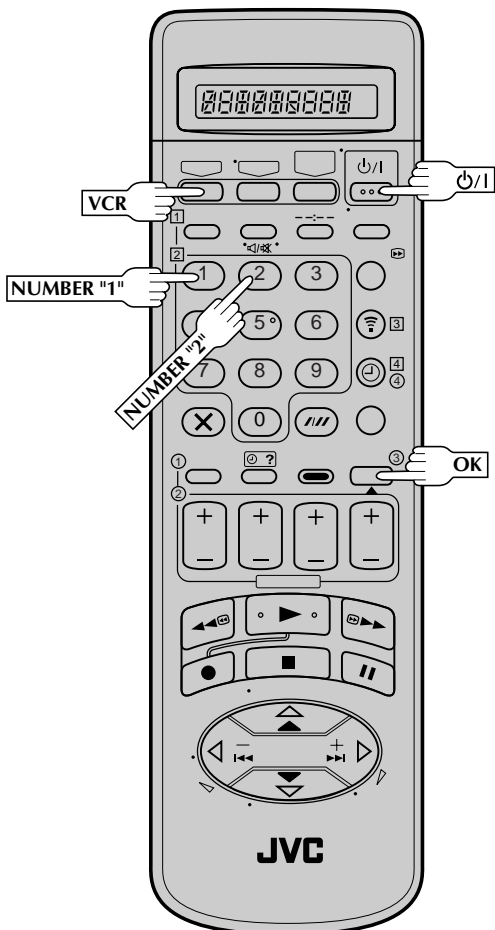

Remote A/B Code Switching

The remote control is capable of controlling two JVC video recorders independently; one set to respond to the remote control's A code control signals and another set to respond to B code control signals. The remote control is preset to send A code signals because your video recorder is initially set to respond to A code signals. You can easily modify your video recorder to respond to B code signals.

SET REMOTE CONTROL CODE

1

Slide the remote control code switch on the recorder to "B".

AND

Press and hold **VCR** on the remote control for over 2 seconds, press the **NUMBER** key "2" and then press **OK**.

NOTES:

- To set the recorder back to respond to A code signals, repeat the same procedure as shown above, except sliding the remote control code switch to "A" and pressing **NUMBER** key "1" instead of "2" in step 1.
- If you don't want to control the recorder by the remote control, slide the remote control code switch to "OFF".

TV Multi-brand Remote Control

Your remote control can operate the basic functions of your TV set. In addition to JVC TVs, other manufacturer's TVs can also be controlled.

Before you start . . .

- Turn off the TV using its remote control.

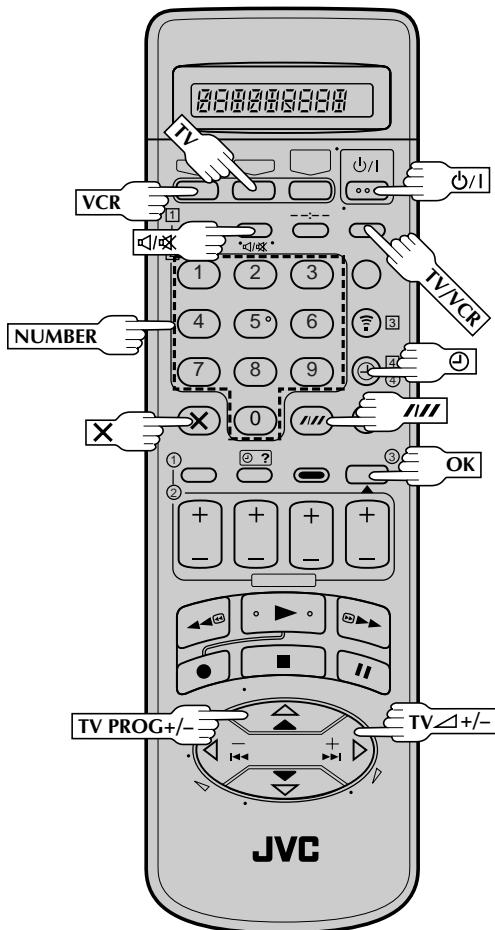

1 SET TV BRAND CODE

Refer to the chart below. Press and hold **TV** on the recorder's remote control for over 2 seconds, enter your TV's brand code using the **NUMBER** keys, then press **OK**.

Check if the TV's power goes on as it should. If it does, try other operations (☞ step 2).

- Once you have set the remote control to operate the TV, you don't have to repeat this step until you replace your remote control's batteries.
- JVC and SAMSUNG have more than one code. If the TV does not function with one code, try entering another.

2 OPERATE TV

First, press **TV** to set the remote control to TV mode, then press the corresponding button: **⏻/⏻**, **TV PROG +/-**, **TV/VCR**, **TV ⏴ +/-** (Volume), **🔇/🔇** (Muting), **NUMBER** keys.

- For some brands of TV, you must press **OK** after having pressed the **NUMBER** keys.
- To return the remote to video recorder control, press **VCR**.

IMPORTANT

Although the provided remote control unit is compatible with JVC televisions, as well as many other models, *it may not work with your TV, or in some instances, may have limited function capability.*

Control Your TV Using Additional Buttons

Use the **NUMBER** keys, and the **IIII** button, **X** button or **⊖** button to select the TV's channel.

- With televisions under Code 01, 02, 07, 10, 11, 14, 20, 23, 24, 25, 27, 33 or 35, the **IIII** button corresponds to the 1-digit/2-digit entry switching button (often labelled **-/-**) of your TV's remote control.
- With televisions under Code 01, 28, 29 or 34, the **X** button corresponds to the 10 + button, and the **⊖** button corresponds to the 20 + button of your TV's remote control.

NOTE:

The way these buttons are used is determined by your TV. Use these buttons as instructed for your TV's remote control.

TV BRAND NAME	CODE
JVC	01, 23, 24, 25
BLAUPUNKT	19
BRANDT	26
FERGUSON	27
FINLUX	30
FUNAI	32
LG/GOLDSTAR	18
GRAETZ	28
GRUNDIG	19
HITACHI	10
ITT	28
LUXOR	28
MITSUBISHI	03
MIVAR	29
NEC	20
NOKIA	31
NORDMENDE	26
PANASONIC	11
PHILIPS	02
SABA	26
SALORA	28
SAMSUNG	02, 12, 33, 34, 35
SELECO	28
SHARP	06
SONY	07
TELEAVIA	26
TELEFUNKEN	26
THOMSON	26
TOSHIBA	14

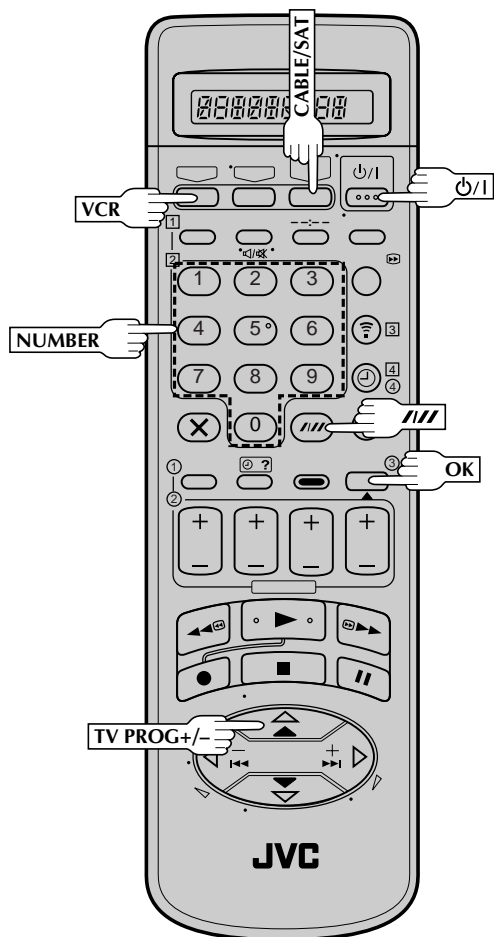

Satellite Receiver Multi-Brand Remote Control

Your remote control can operate the basic functions of your satellite receiver set. In addition to JVC satellite receivers, other manufacturer's satellite receivers can also be controlled.

Before you start . . .

- Turn off the satellite receiver using its remote control.

SET SATELLITE RECEIVER BRAND CODE

1

Refer to the chart below. Press and hold **CABLE/SAT** on the recorder's remote control for over 2 seconds, enter your satellite tuner's brand code using the **NUMBER** keys, then press **OK**.

Check if the satellite receiver's power goes on as it should. If it does, try other operations (→ step 2).

- Once you have set the remote control to operate the satellite receiver, you don't have to repeat this step until you replace your remote control's batteries.
- Some satellite receiver brands have more than one code. If the satellite receiver does not function with one code, try entering another.

OPERATE SATELLITE RECEIVER

2

First, press **CABLE/SAT** to set the remote control to satellite tuner mode, then press the corresponding button: **⏻**, **TV PROG +/-**, **NUMBER** keys.

- For VIDEOWAY or some other brands of satellite receiver, you must press **///** after having pressed the **NUMBER** keys.
- The **NUMBER** buttons may not function with some satellite receivers.
- To return the remote to video recorder control, press **VCR**.

IMPORTANT

Although the provided remote control unit is compatible with JVC satellite receivers, as well as many other models, it may not work with your satellite receiver, or in some instances, may have limited function capability.

SATELLITE TUNER BRAND	CODE
JVC	72, 73
AMSTRAD	60, 61, 62, 63
BT	72
CANAL +	81
FINLUX	68
GRUNDIG	64, 65
HIRSCHMANN	64
ITT	68
JERROLD	75
KATHREIN	70, 71
LUXOR	68
MASPRO	70
NOKIA	68
PACE	65, 67
PANASONIC	74
PHILIPS	66
RFT	69
SALORA	68
SIEMENS	64
SKYMASTER	69
VIDEOWAY	76
WISI	64

Minimizing Picture Degradation While Editing (S-VHS/VHS Mode Only)

Turn on the TV and select the AV mode.

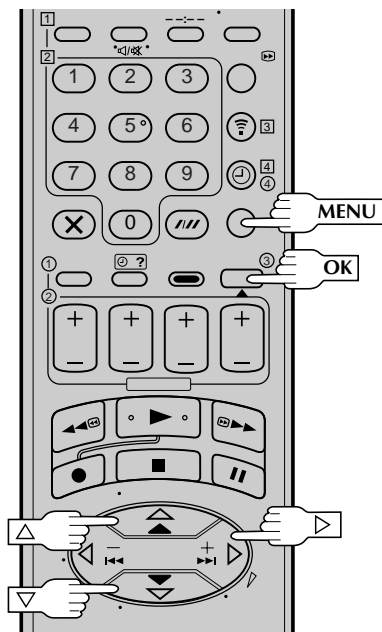

Advantages Of S-VHS Video Recorders

You can edit from VHS to S-VHS, S-VHS to VHS, or, from S-VHS to S-VHS.

- From VHS to S-VHS: Record VHS playback signals in the S-VHS mode. Although the picture quality is inherently limited by that of the original, the edited tape has better picture quality than those made by VHS-to-VHS editing.
- From S-VHS to VHS: Because the picture quality of the source material is very high, the edited tape has better picture quality than those made by VHS-to-VHS editing.
- From S-VHS to S-VHS: All signals will be transferred with minimum degradation.

Picture Control

This feature helps you to adjust the playback picture quality according to your preference. *The default setting is "AUTO."

1 ACCESS MAIN MENU SCREEN

Press **MENU**.

2 ACCESS MODE SET SCREEN

Move the highlighted bar (pointer) to "MODE SET" by pressing Δ / ∇ , then press **OK** or \triangleright .

3 SELECT PICTURE CONTROL SET MODE

Move the highlighted bar (pointer) to "PICTURE CONTROL" by pressing Δ / ∇ , then press **OK** or \triangleright to select the desired mode.

AUTO: Provides optimised picture benefits of B.E.S.T. Picture System. Normally select **AUTO**.

EDIT: Minimizes picture degradation during editing (recording and playback).

SOFT: Reduces image coarseness when viewing overlapped tapes containing a lot of noise.

SHARP: Clearer, sharper-edged picture when viewing images with lots of flat, same-coloured surfaces such as cartoons.

MODE SET	
B. E. S. T.	ON
PICTURE CONTROL	AUTO
AUTO TIMER	OFF
O. S. D.	ON
DIRECT REC	ON
AUTO SP→LP TIMER	OFF
DIGITAL 3R	ON
NEXT PAGE	
[▲▼] → [OK]	
[MENU] : EXIT	

NOTES:

- ♦ When you select **EDIT**, **SOFT** or **SHARP**, the selected mode will not change until you select again.
- ♦ When you select **EDIT** to dub tapes, be sure to select **AUTO** after you finish dubbing the tapes.

4 RETURN TO NORMAL SCREEN

Press **MENU**.

NOTES:

- When **B.E.S.T.** is **OFF**, "PICTURE CONTROL" switches automatically from **AUTO** to **NORM**.
- Select **EDIT** when you are dubbing tapes. Refer to page 48.

Edit From A Camcorder

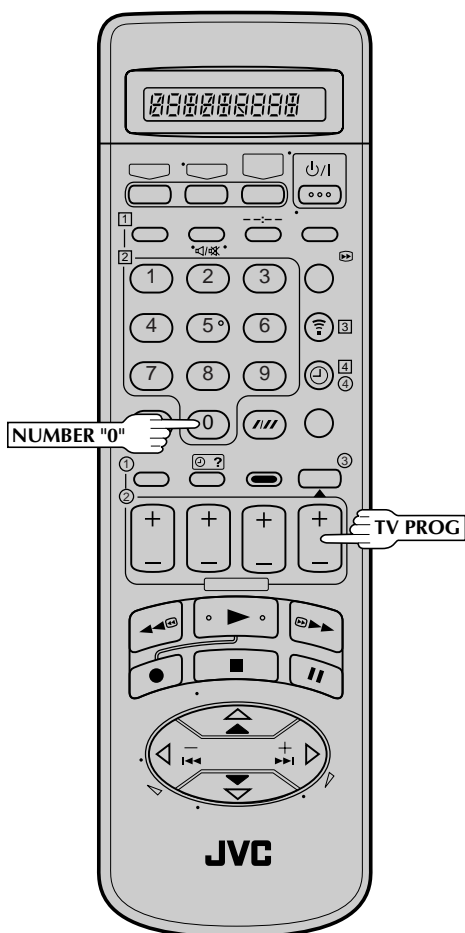

You can use a camcorder as the source player and your video recorder as the recorder.

You can perform digital editing if the camcorder has a DV output connector.

1 MAKE CONNECTIONS

- A** If the camcorder has no S-VIDEO output connector...
... connect the camcorder's AUDIO/VIDEO OUT connectors to the recorder's front panel AUDIO/VIDEO input connectors.
- B** If the camcorder has an S-VIDEO output connector...
... connect the camcorder's S-VIDEO OUT and AUDIO OUT connectors to the recorder's front panel S-VIDEO and AUDIO input connectors.
- C** If the camcorder has a DV OUT connector...
... connect the camcorder's DV OUT connector to the recorder's DV IN connector.
See "DV Sound Setting" (☞ pg. 47) for the DV sound selection.

- When using a monaural camcorder, connect its AUDIO OUT connector to the AUDIO L input connector on your recorder.
- When a Master Edit Control-equipped JVC camcorder is used, the camcorder is capable of controlling the recorder. Refer to the camcorder's instruction manual for operating procedure.

2 SET RECORDING MODE

Set the appropriate recording mode (D-VHS, S-VHS or VHS) (☞ pg. 14, 15, 32, 33).

3 SET RECORDER'S INPUT MODE

Press **NUMBER** key "0" and/or **TV PROG** to select "F-1" for the AUDIO/VIDEO input connectors, "S-2" for the AUDIO/S-VIDEO input connectors, or "I-1" for the DV input connectors, depending on the connectors being used.

4 SET EDIT MODE (S-VHS/VHS MODE ONLY)

See "Picture Control" on page 45.

5 START CAMCORDER

Engage its Play mode.

6 START RECORDER

Engage its Record mode.

NOTES:

- All necessary cables can be obtained from your dealer.
- You can also use another video recorder as the player instead of a camcorder.
- When you select **EDIT** to dub tapes in step 4, be sure to select **AUTO** (or **NORM** when **B.E.S.T.** is set to **OFF**) after you finish dubbing the tapes.
- When you are editing through the **DV IN** connector, the recorder will stop if the player begins playing a blank portion of tape or the signal is interrupted.

A If the camcorder has no S-VIDEO output connector...

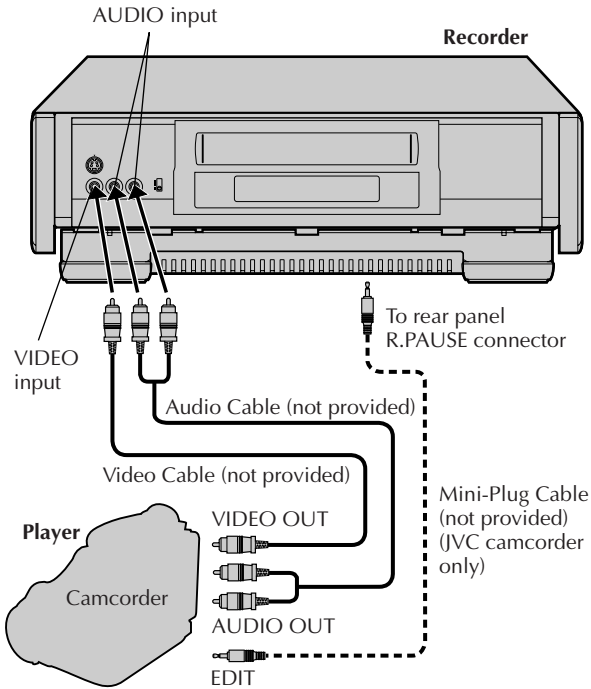

B If the camcorder has an S-VIDEO output connector...

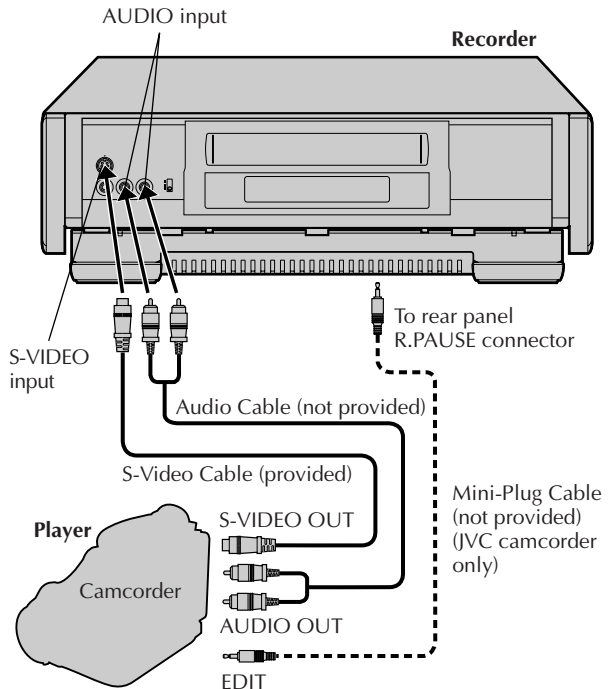

C If the camcorder has a DV OUT connector...

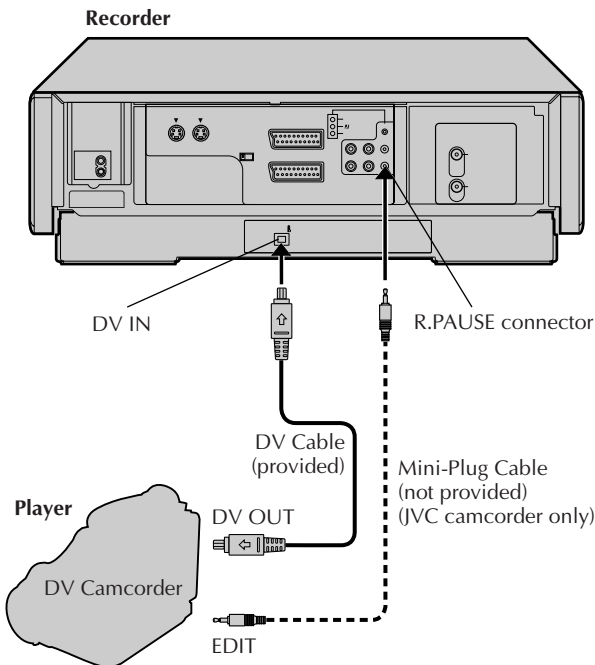

DV Sound Setting

Up to four audio signal channels can be input from a DV camcorder through the DV IN connector (i.Link). This recorder allows you to select and record two of these channels. This setting is used to specify which two channels to record.

- 1 Press **MENU** to access the Main Menu screen.
- 2 Move the highlight bar (pointer) to "MODE SET" by pressing Δ / ∇ , then press **OK** or \triangleright .
- 3 Move the highlight bar (pointer) to "DV SOUND" by pressing Δ / ∇ , then press **OK** or \triangleright to select "SOUND1", "SOUND2" or "FULL".

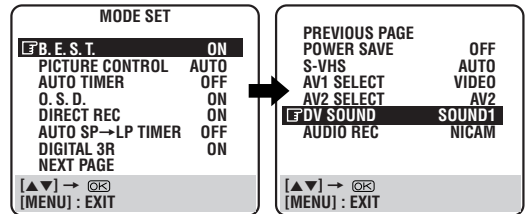

When there are four DV audio channels (32kHz):

- SOUND1: Records the two channels (L/R) of DV SOUND 1.
- SOUND2: Records the two channels (L/R) of DV SOUND 2.
- FULL: Mixes and records both DV SOUND 1 and 2.

When there are two DV audio channels (48kHz):

Because there are only two channels, those two channels are recorded regardless of the DV sound setting.

- 4 Press **MENU** to return to the normal screen.

Edit To Or From Another Video Recorder

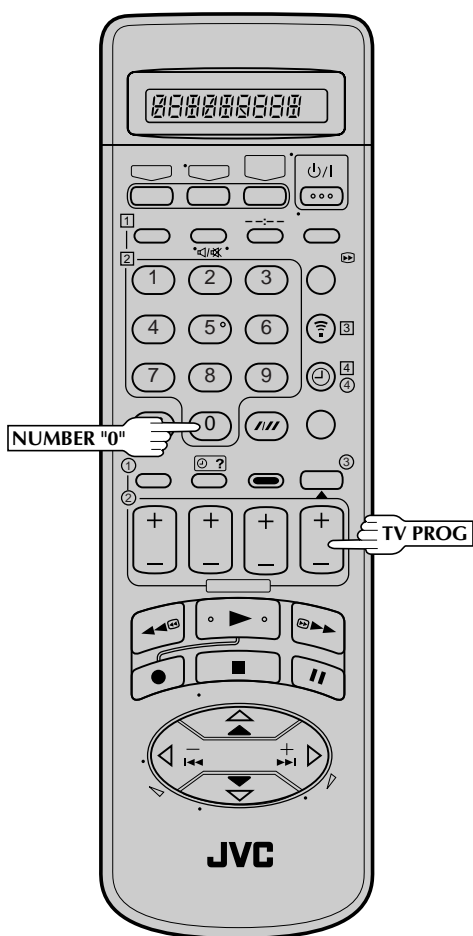

You can use your video recorder as the source player or as the recording deck.

1 MAKE CONNECTIONS

Connect the player's 21-pin SCART connector to the recorder's 21-pin SCART connector as illustrated on page 49.

- A** *When Using Your Video Recorder As The Source Player ...*
... connect its AV1 IN/OUT connector to the recording deck.
- B** *When Using Your Video Recorder As The Recording Deck ...*
... connect its AV2 IN/DECODER or AV1 IN/OUT connector to the source player.
- C** *If Another Recorder Is Compatible With The Y/C Signal ...*
... connect your recorder's AV1 IN/OUT connector to another recorder.

With **C** connection ...

- When using your recorder as the recording deck, set "AV1 SELECT" to "S-VIDEO" and "AV2 SELECT" to "AV2" (☞ pg. 50).
- When using your recorder as the source player, set the AV1 OUT switch on the rear panel to Y/C (☞ pg. 6).

2 SET RECORDING MODE

Set the appropriate recording mode (D-VHS, S-VHS or VHS) (☞ pg. 14, 15, 32, 33).

3 SET RECORDING DECK'S INPUT MODE

Set to AUX. With this video recorder, press **NUMBER** key "0" and/or **TV PROG** to select "L-1" for the AV1 IN/OUT connector, or "L-2" for the AV2 IN/DECODER connector, depending on the connector being used.

- When using the AV2 IN/DECODER connector, set "AV2 SELECT" to the appropriate mode. (☞ pg. 50)

4 SET EDIT MODE (S-VHS/VHS MODE ONLY)

See "Picture Control" on page 45.

5 START SOURCE PLAYER

Engage its Play mode.

6 START RECORDING DECK

Engage its Record mode.

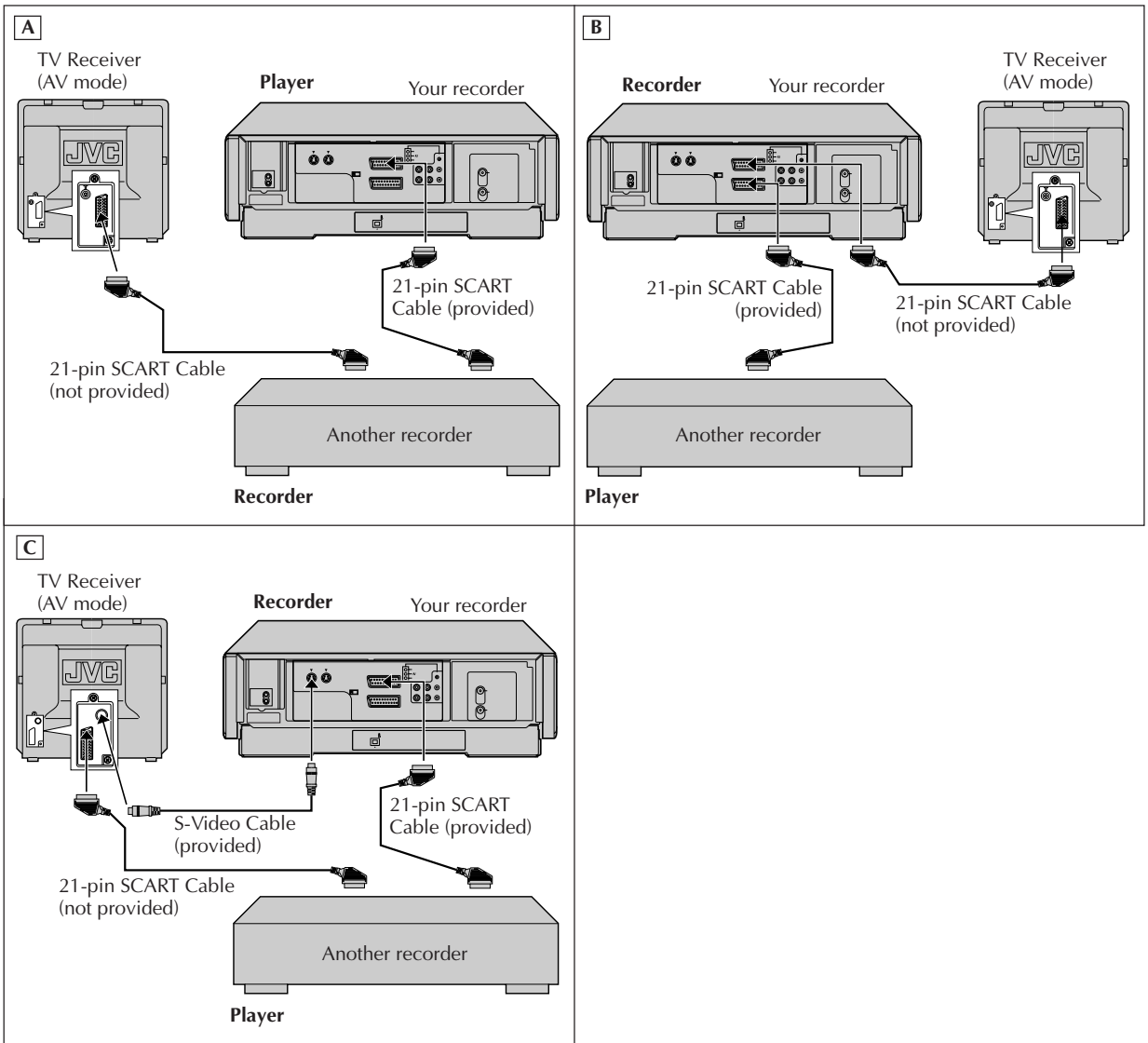

NOTES:

- All necessary cables can be obtained from your dealer.
- For Y/C signal input/output, be sure to use a 21-pin SCART cable that is compatible with the Y/C signal.
- When you select EDIT to dub tapes in step 4, be sure to select AUTO (or NORM when B.E.S.T. is set to OFF) after you finish dubbing the tapes.
- When you use this recorder as the player for editing, be sure to set "O.S.D." to "OFF" before starting (☞ pg. 47).
- If you are using another recorder with S-Video and Audio input/output connectors, you can connect those connectors to this recorder's S-VIDEO IN/S OUT and AUDIO IN/OUT connectors.
 - When Using Your Video Recorder As The Source Player ...
 - ... connect its rear panel S OUT and AUDIO OUT connectors to the recording deck's S-Video and Audio input connectors.
 - When Using Your Video Recorder As The Recording Deck ...
 - ... connect its rear panel S-VIDEO and AUDIO input connectors to the source player's S-Video and Audio output connectors.
 - Then, set the recorder's input mode to "S-1".

AV1 SELECT Setting

Set "AV1 SELECT" to the appropriate mode depending on the type of unit connected to the rear panel AV1 IN/OUT connector of this recorder.

- 1 Press **MENU** to access the Main Menu screen.
 - 2 Press $\Delta \nabla$ to move the highlight bar (pointer) to "MODE SET", then press **OK** or \triangleright .
 - 3 Press $\Delta \nabla$ to move the highlight bar (pointer) to "AV1 SELECT".
 - 4 Press **OK** or \triangleright to select "VIDEO" or "S-VIDEO".
 - a-VIDEO : If a connected device's output is compatible only with regular video signals, set "AV1 SELECT" to "VIDEO".
 - b-S-VIDEO : If a connected device's output is compatible with Y/C signals, set "AV1 SELECT" to "S-VIDEO". This setting will let you take advantage of higher-quality S-VHS pictures.
 - 5 Press **MENU** to return to normal screen.
- If "AV2 SELECT" is set to "DECODER", it is impossible to set "AV1 SELECT" to "S-VIDEO".

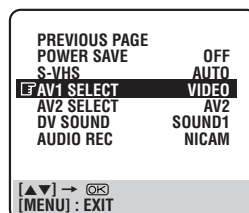
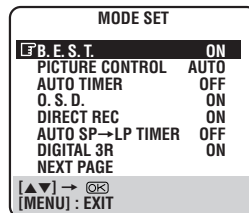

AV2 SELECT Setting

Set "AV2 SELECT" to the appropriate mode depending on the type of unit connected to the rear panel AV2 IN/DECODER connector of this recorder.

- 1 Press **MENU** to access the Main Menu screen.
- 2 Press $\Delta \nabla$ to move the highlight bar (pointer) to "MODE SET", then press **OK** or \triangleright .
- 3 Press $\Delta \nabla$ to move the highlight bar (pointer) to "AV2 SELECT".
- 4 Press **OK** or \triangleright to select "AV2", "DECODER" or "SAT".
 - a-AV2 : To use this recorder as the recording deck with the player connected to the AV2 IN/DECODER connector, or to use the satellite tuner connected to the AV2 IN/DECODER connector.
 - b-DECODER : To use a decoder connected to the AV2 IN/DECODER connector.
 - c-SAT : To view a satellite programme with the TV set while the recorder is in Timer mode, in Stop mode, recording or turned off. (pg. 40)
- 5 Press **MENU** to return to normal screen.

- If you have a satellite receiver or a decoder connected to the AV2 IN/DECODER connector, be sure to set "AV2 SELECT" back to appropriate mode after editing.
- If you're not connecting a satellite receiver or a decoder to the AV2 IN/DECODER connector, leave "AV2 SELECT" set to "AV2".
- The default setting is "AV2"; if the recorder's memory backup has expired due to a power cut or because the AC was removed from the recorder, "AV2" will be automatically selected when the power is restored to the recorder. If you are using a satellite receiver or a decoder, be sure to set "AV2 SELECT" back to appropriate mode.
- If the AV1 OUT switch on the rear panel is set to Y/C, it is impossible to set "AV2 SELECT" to "DECODER".

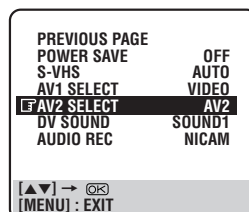
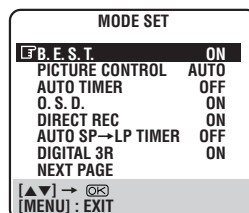

Synchro Editing (S-VHS/VHS Mode Only)

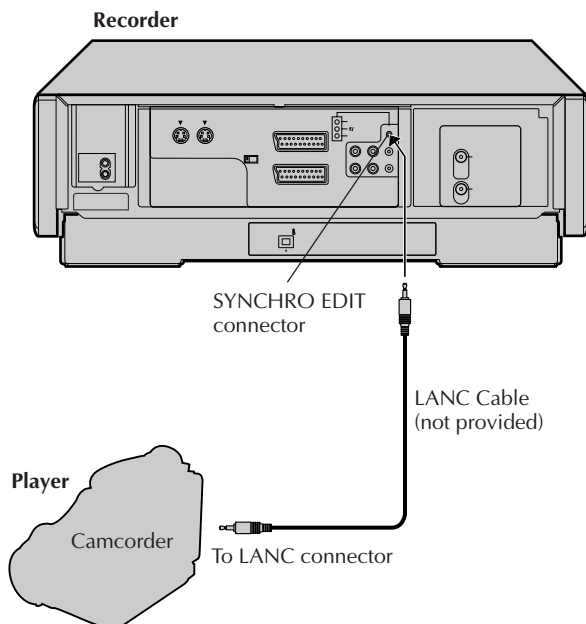
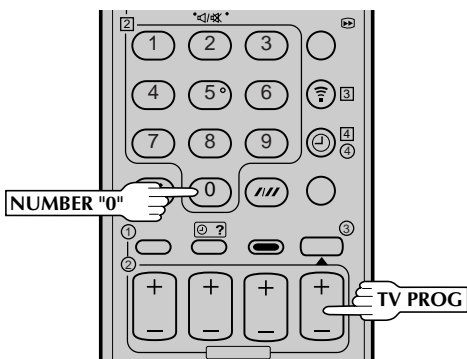
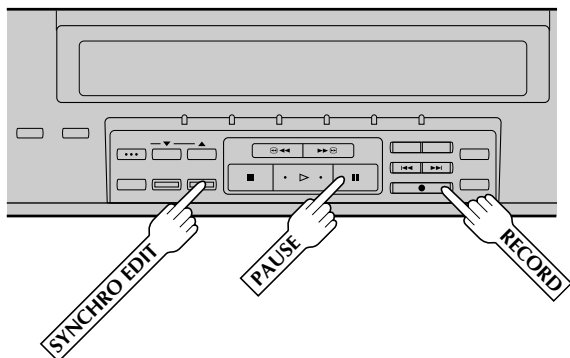

The Synchro Editing function synchronizes the start of the playback and recording operations when starting an edit operation using a camcorder equipped with a LANC connector and your video recorder.

1 MAKE CONNECTIONS

Connect your recorder to camcorder (☞ pg. 46), and connect your recorder's SYNCHRO EDIT connector to the camcorder's LANC connector.

2 SET RECORDING MODE

Set the appropriate recording mode (S-VHS or VHS) (☞ pg. 15, 32, 33).

3 SET RECORDER'S INPUT MODE

Set the appropriate input mode, depending on the connectors being used in step 1.

4 SET EDIT MODE

See "Picture Control" on page 45.

5 LOCATE START POINT

Start playback of the tape in the camcorder, and pause playback when you find the point where you want to start editing. Press and hold **PAUSE** and press **RECORD** on your recorder so that the recorder enters the Record-Pause Mode.

6 START SYNCHRO EDITING

Press **SYNCHRO EDIT**.

7 PAUSE SYNCHRO EDITING

Press **SYNCHRO EDIT** again.

- Repeat steps 5 – 7 as necessary.

NOTES:

- The Synchro Editing function is impossible with the connection using DV connector.
- The Synchro Editing function may not work with the initial part of a camcorder tape.
- The Synchro Editing function cannot be used when using the JLIP function. (Pressing **SYNCHRO EDIT** cancels the JLIP function.)
- The Synchro Editing function may not work properly with some type of camcorder.
- The Synchro Editing function enables the recorder to control a camcorder which has a LANC connector. It is not possible to control the recorder by a camcorder, even though the camcorder has a LANC connector.
- When you select **EDIT** to dub tapes in step 4, be sure to select **AUTO** (or **NORM** when **B.E.S.T.** is set to **OFF**) after you finish dubbing the tapes.

Information On J Terminal

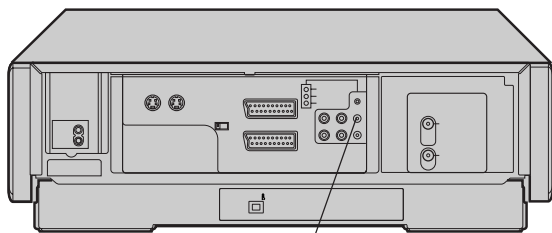

J terminal

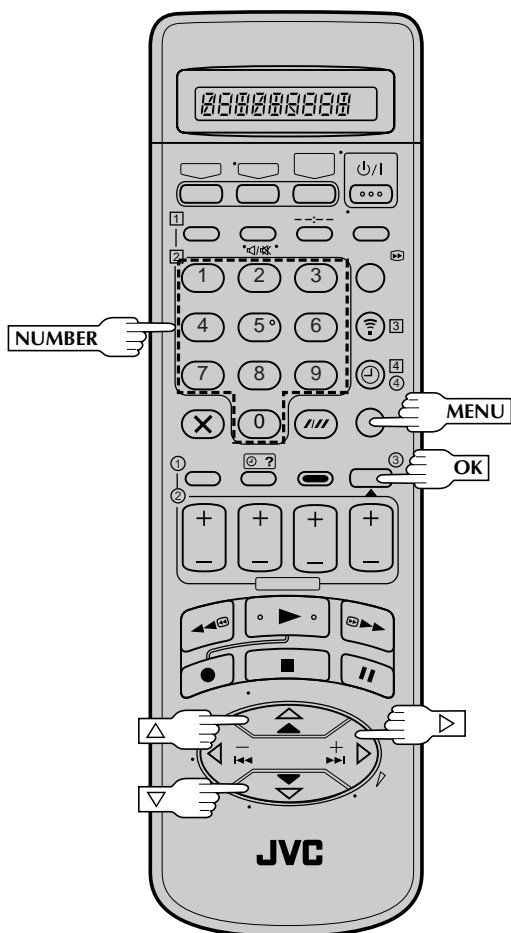

J Terminal (JLIP (Joint Level Interface Protocol) Connector)

The J Terminal is used to connect the recorder to a personal computer or similar device to allow computerized control of the recorder during editing and certain other operations.

Example:

With the optional JLIP VIDEO CAPTURE BOX GV-CB3E:

- Allows you to capture still images from the recorder into a personal computer.

For further details consult your nearest JVC dealer.

JLIP ID Number

Your recorder has its own JLIP ID number. This ID number must be unique when your recorder is connected to another device via its J terminal. The ID Number is preset to "1" at the factory. You can change this number to any number between "1" and "99". If it is necessary to change the JLIP ID number perform the following steps.

1 ACCESS MAIN MENU SCREEN

Press **MENU**.

2 ACCESS INITIAL SET SCREEN

Press $\Delta \nabla$ to move the highlight bar (pointer) to "INITIAL SET", then press **OK** or \triangleright .

3 ACCESS JLIP ID NO. SET SCREEN

Press $\Delta \nabla$ and move the highlight bar (pointer) to "JLIP ID NO. SET", then press **OK** or \triangleright .

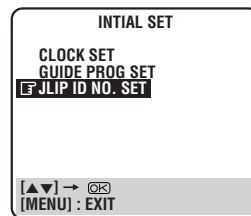

4 SET JLIP ID NUMBER

Press **NUMBER** keys to enter the desired ID number.

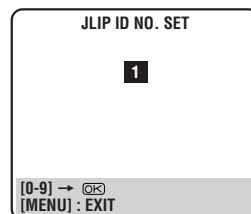

5 RETURN TO NORMAL SCREEN

Press **OK**.

Other Functions

Turn on the TV and select the AV mode.

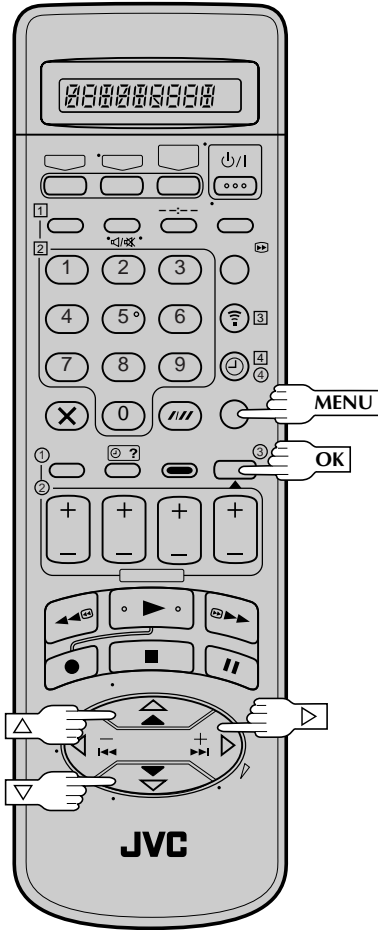

On-Screen Display

You can choose whether or not to have various operational indicators appear on screen, by setting this function ON or OFF.

1 ACCESS MAIN MENU SCREEN

Press **MENU**.

2 ACCESS MODE SET SCREEN

Move the highlight bar (pointer) to "MODE SET" by pressing $\Delta \nabla$, then press **OK** or \triangleright .

3 ENABLE/DISABLE ON-SCREEN DISPLAY

The default setting is "ON", so if you want on-screen displays, leave the setting as it is and go to step 4. If you don't want the displays to appear, press $\Delta \nabla$ to move the highlight bar (pointer) to "O.S.D." and press **OK** or \triangleright to set "O.S.D." to "OFF".

MODE SET	
B. E. S. T.	ON
PICTURE CONTROL	AUTO OFF
AUTO TIMER	OFF
O.S.D.	ON
DIRECT REC	ON
AUTO SP→LP TIMER	OFF ON
DIGITAL 3R	ON
NEXT PAGE	
[$\Delta \nabla$] → [OK]	
[MENU] : EXIT	

4 RETURN TO NORMAL

Press **MENU**.

NOTES:

- When you use this recorder as the player for editing, be sure to set "O.S.D." to "OFF" before starting.
- During playback, the operation mode indicators may sometimes be disturbed depending on the type of tape being used.

The superimposed indication on the TV screen tells you what the recorder is doing.

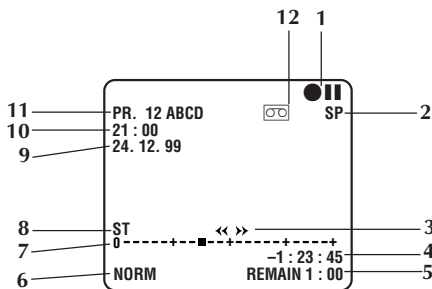

- 1- Operation mode indicators
- 2- Tape speed SP/LP/EP (EP is for NTSC playback only)
- 3- Tape direction
- 4- Counter display
- 5- Tape remaining time indicator (☞ pg. 17)
- 6- Audio mode display (☞ pg. 39)
- 7- Tape position indicator (☞ pg. 12)
- 8- Type of Broadcast (☞ pg. 38)
- 9- Current day/month/year
- 10- Clock display
- 11- Channel position number and station name/Aux. indicator (DV, L-1, L-2, F-1, S-1 or S-2)
- 12- Cassette loaded mark

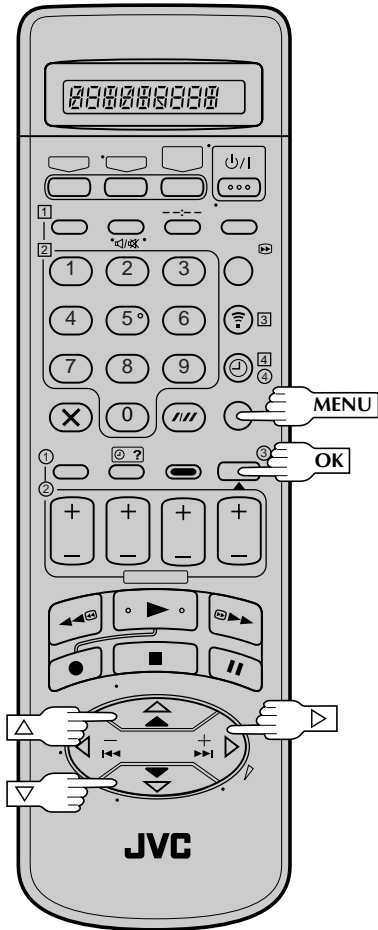

Power Save Mode

You can reduce the power consumption while the recorder is turned off.

1 ACCESS MAIN MENU SCREEN

Press MENU.

2 ACCESS MODE SET SCREEN

Press Δ / ∇ to move the highlight bar (pointer) to "MODE SET", then press OK or \triangleright .

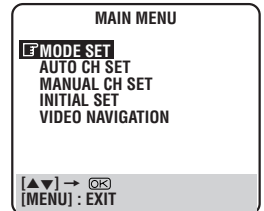

3 SELECT POWER SAVE MODE

Press Δ / ∇ to move the highlight bar (pointer) to "POWER SAVE", then press OK or \triangleright to set to "ON".

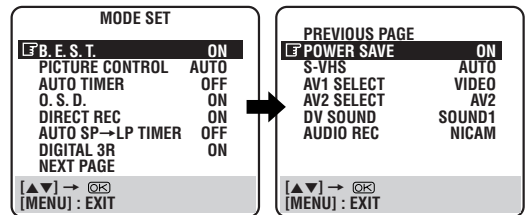

4 RETURN TO NORMAL SCREEN

Press MENU.

NOTES:

- During Power Save, the display panel will be turned off.
- The Just Clock function (see pg. 66) does not work while the Power Save mode is engaged.
- While the recorder is in the Power Save mode, the picture may be distorted momentarily when you turn on/off the recorder.
- Power Save does not work when ...
 - ... the recorder is in the Timer mode.
 - ... the recorder's power is turned off after timer-recording (or Instant Timer Recording).
 - ... the Auto Satellite Prog Recording mode is engaged (see pg. 40).
 - ... "AV2 SELECT" is set to "DECODER" or "SAT" (see pg. 50).

Auto SP→LP Timer (S-VHS/VHS Mode Only)

If, when timer-recording in SP mode, there is not enough tape to record the entire programme, the recorder automatically switches to LP mode to allow complete recording.

For Example . . .

Recording a programme of 210 minutes in length onto a 180-minute tape

Approximately 150 minutes Approximately 60 minutes

SP mode	LP mode
---------	---------

Total 210 minutes

Make sure you set "AUTO SP→LP TIMER" to "ON" at the Mode Set screen before the timer-recording starts.

1 ACCESS MAIN MENU SCREEN

Press **MENU**.

2 ACCESS MODE SET SCREEN

Press $\Delta\nabla$ to move the highlight bar (pointer) to "MODE SET", then press **OK** or \triangleright .

3 SELECT MODE

Press $\Delta\nabla$ to move the highlight bar (pointer) to "AUTO SP→LP TIMER", then press **OK** or \triangleright to select "ON".

MODE SET	
B. E. S. T.	ON
PICTURE CONTROL	AUTO
AUTO TIMER	OFF
O. S. D.	ON
DIRECT REC	ON
AUTO SP→LP TIMER	ON
DIGITAL 3R	ON
NEXT PAGE	
[$\Delta\nabla$] → [OK] [MENU] : EXIT	

4 RETURN TO NORMAL SCREEN

Press **MENU**.

NOTES:

- The Auto SP→LP Timer feature is not available during ITR (Instant Timer Recording), and the feature will not work properly with any tapes longer than E-180 or with some tapes of shorter lengths.
- If you have programmed the recorder to timer-record 2 or more programmes, the second programme and those thereafter may not fit on the tape if you set "AUTO SP→LP TIMER" to "ON". In this case, make sure the mode is not engaged, then set the tape speed manually during timer programming.
- In order to ensure that the recording fits on the tape, this feature may leave a short non-recorded section at the end of the tape.
- There may be some picture noise and sound disturbance at the point on the tape where the recorder switches from SP to LP mode.
- If you perform timer recording with both PDC and the Auto SP→LP Timer activated, and the programme goes beyond its originally scheduled length, there may be times when the programme cannot be recorded in its entirety.

Auto Timer

When the Auto Timer is set to ON the timer is automatically engaged when the recorder power is turned off and automatically disengaged when the recorder is powered back on.

1 ACCESS MAIN MENU SCREEN

Press **MENU**.

2 ACCESS MODE SET SCREEN

Press $\Delta\nabla$ to move the highlight bar (pointer) to "MODE SET", then press **OK** or \triangleright .

MAIN MENU	
LP MODE SET	
AUTO CH SET	
MANUAL CH SET	
INITIAL SET	
VIDEO NAVIGATION	
[$\Delta\nabla$] → [OK] [MENU] : EXIT	

3 SELECT MODE

Press $\Delta\nabla$ to move the highlight bar (pointer) to "AUTO TIMER", then press **OK** or \triangleright to select either "ON" or "OFF".

MODE SET	
B. E. S. T.	ON
PICTURE CONTROL	AUTO
AUTO TIMER	ON
O. S. D.	ON
DIRECT REC	ON
AUTO SP→LP TIMER	OFF
DIGITAL 3R	ON
NEXT PAGE	
[$\Delta\nabla$] → [OK] [MENU] : EXIT	

4 RETURN TO NORMAL SCREEN

Press **MENU**.

NOTE:

For safety, when Auto timer is set to "OFF", all other recorder functions are disabled while the Timer mode is engaged. To disengage the timer, press \ominus (or \ominus **TIMER**).

Next Function Memory

The Next Function Memory "tells" the recorder what to do after rewinding. Before continuing, make sure the recorder is in the Stop mode.

- a- For Automatic Start Of Playback After Tape Rewind . . .
... press **REW**, then press **PLAY** within 2 seconds.
- b- For Automatic Power Off After Tape Rewind . . .
... press **REW**, then press $\odot/1$ within 2 seconds.
- c- For Automatic Timer Standby After Tape Rewind . . .
... press **REW**, then press \ominus (or \ominus **TIMER**) within 2 seconds.

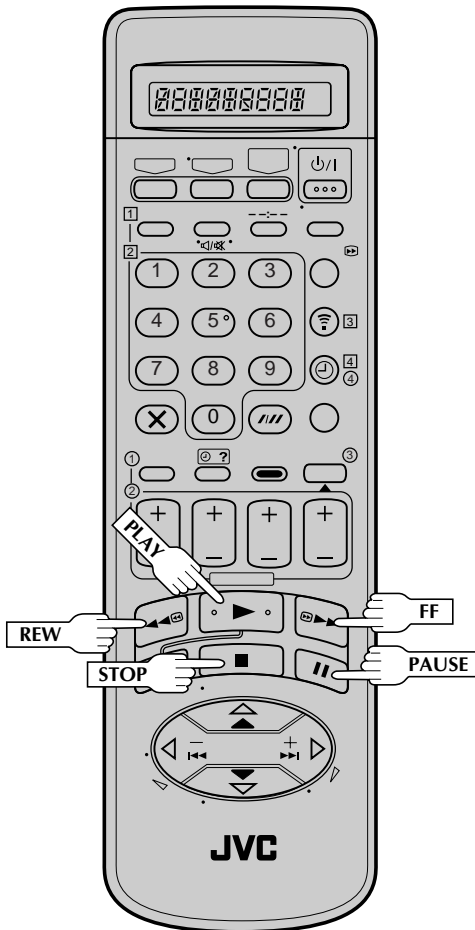

Repeat Playback

Your video recorder can automatically play back the whole tape 50 times repeatedly.

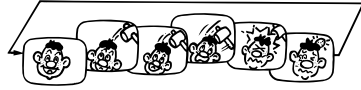

1 START PLAYBACK

Press **PLAY**.

2 ACTIVATE REPEAT PLAYBACK

Press **PLAY** and hold for over 5 seconds, then release.

- The Play indicator (▶) on the display panel blinks slowly.
- The tape plays 50 times automatically, and then stops.

3 STOP PLAYBACK

Press **STOP** at any time to stop playback.

NOTES:

- Pressing **PLAY**, **REW**, **FF** or **PAUSE** also stops Repeat Playback.
- For a cassette recorded in D-VHS mode, Repeat Playback is possible only if the cassette was recorded in STD mode.

NTSC Playback

Your video recorder is equipped with NTSC circuitry that can play back NTSC tapes.

1 LOAD A CASSETTE

Insert a cassette recorded in NTSC.

2 START PLAYBACK

Press **PLAY**.

- "NTSC→PAL" appears on the screen for about 5 seconds.
- Some TVs shrink the picture vertically and place black bars at the top and bottom of the screen. This is not a malfunction on the part of either the video recorder or the TV.
- The picture may roll up and down. This can be corrected using the V-HOLD control found on some TVs. (This cannot be corrected if the TV does not have a V-HOLD control.)
- The counter and tape remaining time readings will be incorrect.
- During search, still, or frame-by-frame playback, the picture will be distorted, and there may be a loss of colour.
- Depending on the type of TV, the top and bottom portions of superimposed displays may be cut off during NTSC playback.

Connection To A Stereo System

These instructions enable you to connect your video recorder to your Hi-Fi stereo system (if you have one) and listen to the soundtrack through the stereo.

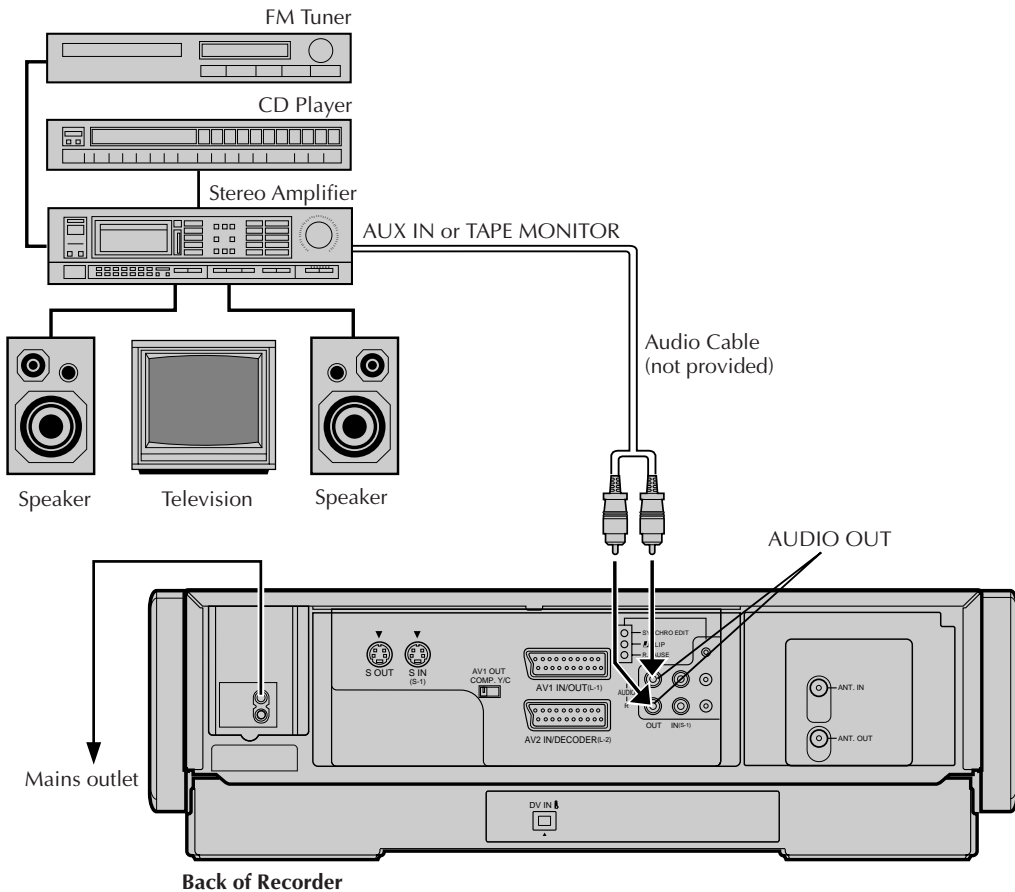

1 MAKE CONNECTIONS

Connect the AUDIO OUT L and R connectors on your video recorder to the AUX IN or TAPE MONITOR terminals on your stereo system's receiver or amplifier.

NOTES:

- When connecting your recorder's audio output connectors to a stereo amplifier, make sure you connect L and R correctly.
- If you can receive NICAM TV broadcasts in your area, this recorder can record them independently of the TV set and play them back through the connected stereo system.
- When listening to sound through the connected stereo system, turn the TV's volume down completely.

CAUTIONS:

- This recorder has a dynamic range of more than 80 dB with regards to its Hi-Fi audio capability. It is recommended that you check the maximum level if you are going to listen to the Hi-Fi audio signals through a stereo amplifier. A sudden surge in the input level to the speakers may damage them.
- Some speakers and televisions are specially shielded to prevent television interference. If both are of the non-shielded type, do not place the speakers adjacent to the TV set as this can adversely affect the video playback picture.

Tuner Set

Turn on the TV and select the AV mode.

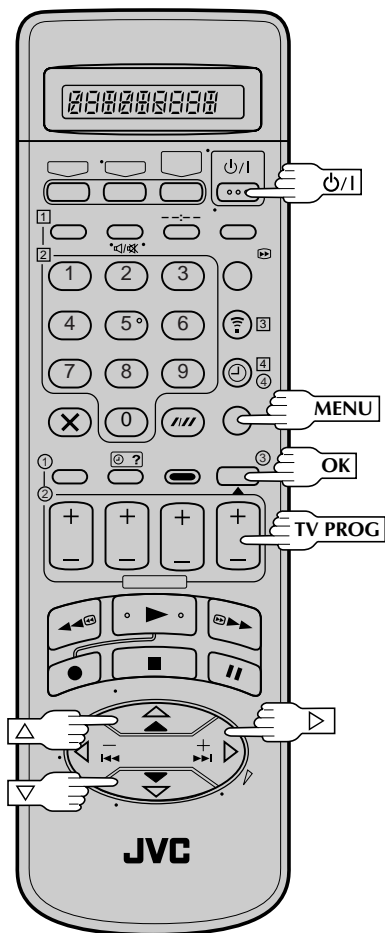

IMPORTANT

- Perform the following steps only if —
- Auto Channel Set has not been set correctly by Auto Set Up function (pg. 8) or Preset Download (pg. 9).
 - you have moved to a different area or if a new station starts broadcasting in your area.

Your recorder needs to memorise all necessary stations in preset positions in order to record TV programmes. Auto Channel Set automatically assigns all receivable stations in your area to call them up by using the **TV PROG** buttons without going through any vacant channel.

Auto Channel Set

TURN ON THE RECORDER

Press **⏻/I**.

ACCESS MAIN MENU SCREEN

Press **MENU**.

PERFORM AUTO CHANNEL SET

Move the highlight bar (pointer) to "AUTO CH SET" by pressing **Δ∇**, then press **OK** or **▷**.

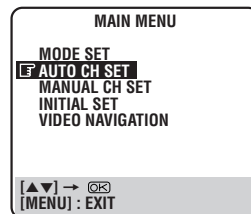

- The Auto Set screen appears, and remains on screen while the recorder searches for receivable stations. As Auto Channel Set progresses, the "■" mark on the screen moves from left to right. Wait until the screen as shown in step 4 appears.

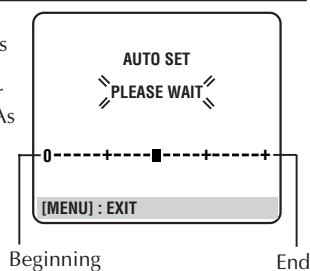

- Auto Channel Set usually takes about 4 – 12 minutes; the duration varies by area.

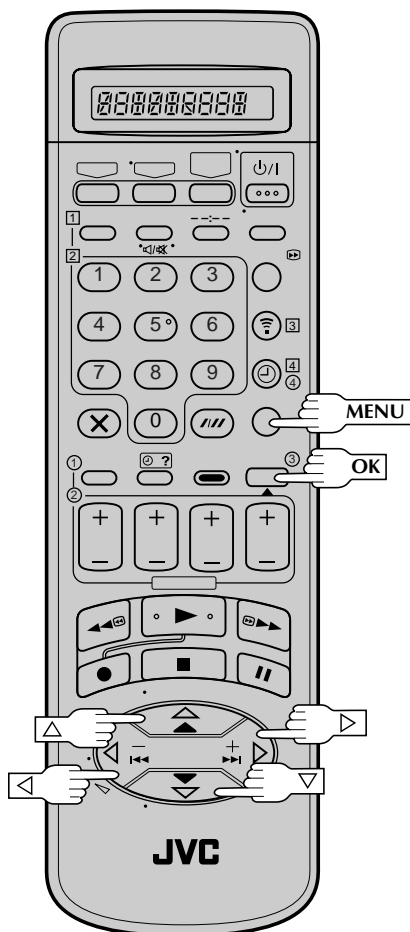

4

VIEW CONFIRMATION SCREEN

After "SCAN COMPLETED" is displayed on the screen for about 5 seconds, a Confirmation screen looking like the one on the right appears. The stations your recorder located appear on a Confirmation screen — preset positions (PR), channels (CH) and station names (ID — see pg. 63). The blueback screen and the programme currently being broadcast by the station which is blinking appear alternately for 8 seconds each.

PR	CH	ID	PR	CH	ID
01	26	BBC1	08	----	----
02	33	BBC2	09	----	----
03	23	ITV	10	----	----
04	30	CH4	11	----	----
05	37	CH5	12	----	----
06	----	----	13	----	----
07	----	----	14	----	----

[▲▼◀▶]
 → [OK] : EDIT
 → [X] : DELETE
 [MENU] : EXIT

To view the next page, use the ▲▼◀▶ button on the remote control.

- The Guide Program numbers will also be set automatically during Auto channel Set.

RETURN TO NORMAL SCREEN

5

Press **MENU**.

- Using the Confirmation screen, you can skip or add preset positions, enter station names and perform other operations. Refer to pages 60 – 64 for the procedures.
- Depending on reception conditions, the stations may, on occasion, not be stored in order, and the station names may not be stored correctly.

IMPORTANT

- In certain reception conditions, station names may not be stored correctly, and auto Guide Program Number Set may not work properly. If the Guide Program numbers are not set properly, when you timer-record a TV programme using VIDEO Plus+, the recorder will record a TV programme of a different station. When programming the timer using VIDEO Plus+, be sure to check that the preset position corresponding to the broadcasting station you wish to record has been selected (see pg. 18, "VIDEO Plus+® Timer Programming").
- Your video recorder memorizes all detected stations even if reception of some of them is poor. In these cases picture quality may be poor. To delete those stations which have an unacceptable picture see "Delete A Channel" on page 61.

NOTES:

- Fine tuning is performed automatically during Auto Channel Set. If you wish to perform it manually, refer to page 61.
- If, for any reason, you perform Auto Channel Set when the aerial cable is not connected properly, "SCAN COMPLETED -NO SIGNAL-" appears on the screen in step 4. When this happens, make sure of the aerial connection and press **OK**; Auto Channel Set will take place again.

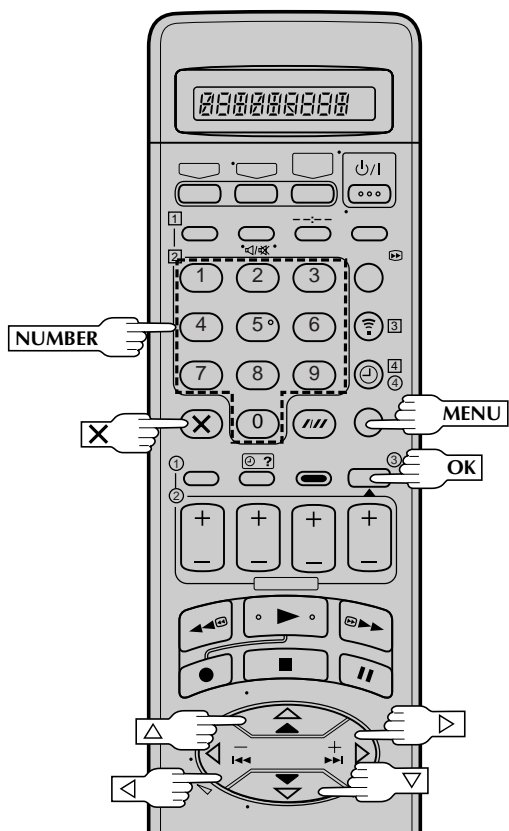

Storing Channels Manually

To store channels that were not stored during Auto Set Up (☞ pg. 8), Preset Download (☞ pg. 9) or Auto Channel Set (☞ pg. 58).

1 ACCESS MAIN MENU

Press **MENU**.

2 ACCESS CONFIRMATION SCREEN

Press $\Delta \nabla$ to move the highlight bar (pointer) to "MANUAL CH SET", then press **OK** or \triangleright . The Confirmation screen appears.

3 SELECT POSITION

Press $\Delta \nabla \triangleleft \triangleright$ until an open position in which you want to store a channel begins blinking, then press **OK**. The Manual Channel Set screen appears.

(Ex.) To store in position 6.

PR	CH	ID	PR	CH	ID
01	26	BBC1	08	----	----
02	33	BBC2	09	----	----
03	23	ITV	10	----	----
04	30	CH4	11	----	----
05	37	CH5	12	----	----
06	----	13	----	----	----
07	----	14	----	----	----

[$\Delta \nabla \triangleleft \triangleright$]:
 \rightarrow [OK]: EDIT
 \rightarrow [X]: DELETE
 [MENU]: EXIT

The blueback screen and the programme currently being broadcast by the selected channel appear alternately for 8 seconds each.

4 SELECT BAND

Press $\Delta \nabla$ to change the band between CH (regular) and CC (cable), then press \triangleright .

```
PR CH ID FINE DECODER
06 CH01 ---- +/- OFF
```

[$\Delta \nabla$]: SELECT
 [$\triangleleft \triangleright$]: CURSOR \leftrightarrow
 [OK]: OK
 [MENU]: EXIT

The blueback screen and the programme currently being broadcast by the selected channel appear alternately for 8 seconds each.

5 INPUT CHANNEL

Press the **NUMBER** keys to input the channel number you want to store.

```
PR CH ID FINE DECODER
06 CH21 ---- +/- OFF
```

[$\Delta \nabla$]: SELECT
 [$\triangleleft \triangleright$]: CURSOR \leftrightarrow
 [OK]: OK
 [MENU]: EXIT

The blueback screen and the programme currently being broadcast by the selected channel appear alternately for 8 seconds each.

- To input the registered station name (ID - ☞ pg. 63), press \triangleright until "- -" (ID setting) begins blinking, then press $\Delta \nabla$.
- For fine tuning adjustment, press \triangleright until "+/-" begins blinking, then press $\Delta \nabla$. While tuning, "+" or "-" appears.
- When "AV2 SELECT" is set to "AV2" or "SAT", the "DECODER" setting cannot be changed (☞ pg. 50).

6 ENTER NEW CHANNEL INFORMATION

Press **OK** and the Confirmation screen appears.

- Repeat steps 3 through 6 as necessary.

7 CLOSE CONFIRMATION SCREEN

Press **MENU**.

- To change positions, see "Change Station Preset Position" (☞ pg. 61).
- If you wish to set station names other than the ones registered in your recorder, ☞ "Set Stations (B)" on pg. 62.

ATTENTION

Guide Program numbers are not set when channels are stored manually. If an attempt is made at timer programming with VIDEO Plus+ in this state, the "GUIDE PROG SET" screen appears; set the Guide Program numbers on this screen. ☞ "ATTENTION - Regarding Guide Program Number Set" on pg. 19.

Or perform "Guide Program Number Set" (☞ pg. 65).

Delete A Channel

Perform steps 1 and 2 of "Storing Channels Manually" on page 60 to access the Confirmation screen before continuing.

- 1** **SELECT ITEM**
Press $\Delta \nabla \triangleleft \triangleright$ until the item you want to delete begins blinking.
- 2** **DELETE CHANNEL**
Press \times .
 - The item directly beneath the cancelled one moves up one line.
 - Repeat steps 1 and 2 as necessary.
- 3** **CLOSE CONFIRMATION SCREEN**
Press **MENU**.

Change Station Preset Position

Perform steps 1 and 2 of "Storing Channels Manually" on page 60 to access the Confirmation screen before continuing.

- 1** **SELECT ITEM**
Press $\Delta \nabla \triangleleft \triangleright$ until the item you want to move begins blinking. Then press **OK** and the station name (ID) and its channel (CH) number begin blinking.
 - 2** **SELECT NEW POSITION**
Press $\Delta \nabla \triangleleft \triangleright$ to move the station to the new preset position, then press **OK**.
Example: If you moved the station in position 4 to position 2, the stations originally in positions 2 and 3 each move down one space.
- | PR | CH | ID | PR | CH | ID | PR | CH | ID | PR | CH | ID |
|----|------|------|----|------|------|----|------|------|----|------|------|
| 01 | 26 | BBC1 | 08 | ---- | ---- | 01 | 26 | BBC1 | 08 | ---- | ---- |
| 02 | 23 | ITV | 09 | ---- | ---- | 02 | 33 | BBC2 | 09 | ---- | ---- |
| 03 | 30 | CH4 | 10 | ---- | ---- | 03 | 23 | ITV | 10 | ---- | ---- |
| 04 | 33 | BBC2 | 11 | ---- | ---- | 04 | 30 | CH4 | 11 | ---- | ---- |
| 05 | 37 | CH5 | 12 | ---- | ---- | 05 | 37 | CH5 | 12 | ---- | ---- |
| 06 | ---- | ---- | 13 | ---- | ---- | 06 | ---- | ---- | 13 | ---- | ---- |
| 07 | ---- | ---- | 14 | ---- | ---- | 07 | ---- | ---- | 14 | ---- | ---- |
- [$\Delta \nabla \triangleleft \triangleright$]: MOVE
 \otimes : MANUAL CH SET
 [MENU]: EXIT

➔

[$\Delta \nabla \triangleleft \triangleright$]: MOVE → \otimes
 [MENU]: EXIT
- Repeat steps 1 and 2 as necessary.
 - 3** **CLOSE CONFIRMATION SCREEN**
Press **MENU**.

Fine-Tuning Channels Already Stored

Perform steps 1 and 2 of "Storing Channels Manually" on page 60 to access the Confirmation screen before continuing.

- 1** **SELECT CHANNEL TO FINE-TUNE**
Press $\Delta \nabla \triangleleft \triangleright$ until the channel you want to tune begins blinking.
- 2** **ACCESS MANUAL CHANNEL SET SCREEN**
Press **OK** twice. The Manual Channel Set screen appears.
- 3** **PERFORM TUNING**
Press \triangleright until "+/-" begins blinking, then press $\Delta \nabla$ until the picture is clearest. Then press **OK**.
 - The Confirmation screen appears.
 - Repeat steps 1 through 3 as necessary.
- 4** **CLOSE CONFIRMATION SCREEN**
Press **MENU**.

ATTENTION

If channel positions are changed or deleted, the Guide Program numbers that have been set are reset.

- Example 1: If a channel is deleted, all the Guide Program numbers are reset.
- Example 2: If a channel is changed from position 4 to position 2, the Guide Program numbers above position 4 are reset.
- Example 3: If a channel is changed from position 4 to position 6, the Guide Program numbers above position 6 are reset.

* In Examples 2 and 3, if the channel is moved to position 10 before **OK** is pressed, the Guide Program numbers above position 10 are reset.

If an attempt is made at timer programming with VIDEO Plus+ in this state, the "GUIDE PROG SET" screen appears; set the Guide Program numbers on this screen. \square "ATTENTION – Regarding Guide Program Number Set" on pg. 19.

Or perform "Guide Program Number Set" (\square pg. 65).

When Receiving A Scrambled Broadcast

1

SELECT DECODER MODE

Set "AV2 SELECT" to "DECODER" (☞ pg. 50).

2

ACCESS CONFIRMATION SCREEN

Perform steps 1 and 2 of "Storing Channels Manually" on page 60.

3

SELECT POSITION

Press $\Delta \nabla \triangleleft \triangleright$ to select the channel position broadcasting scrambled programmes, then press **OK** twice.

4

CHANGE DECODER SETTING

Press \triangleright until "OFF" (decoder setting) begins blinking, and set it to "ON" by pressing $\Delta \nabla$.

5

RETURN TO CONFIRMATION SCREEN

Press **OK**.

- Repeat steps 3 through 5 as necessary.

6

CLOSE CONFIRMATION SCREEN

Press **MENU**.

NOTE:

Scrambled programmes are not currently broadcasted in the U.K.

Set Stations (A)

Set station names that are registered in your recorder.

Perform steps 1 and 2 of "Storing Channels Manually" on page 60 to access the Confirmation screen before continuing.

1

SELECT ITEM

Press $\Delta \nabla \triangleleft \triangleright$ until the item you want begins blinking.

2

ACCESS MANUAL CHANNEL SET SCREEN

Press **OK** twice.

3

SELECT NEW STATION

Press \triangleright until the station name (ID) begins blinking, then press $\Delta \nabla$ until the new station's name (ID) you want to store begins blinking.

Registered station names (☞ pg. 63) appear as you press $\Delta \nabla$.

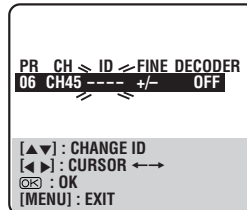

4

SWITCH STATIONS

Press **OK**.

- The Confirmation screen appears.
- Repeat steps 1 through 4 as necessary.

5

CLOSE CONFIRMATION SCREEN

Press **MENU**.

Set Stations (B)

Set station names other than the ones registered in your recorder.

Perform steps 1 and 2 of "Storing Channels Manually" on page 60 to access the Confirmation screen and then perform steps 1 and 2 of "Set Stations (A)" on the left before continuing.

1

SELECT STATION NAME CHARACTER

Press \triangleright until the first letter of the station name begins blinking.

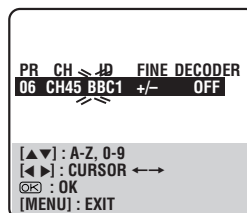

2

ENTER NEW CHARACTER

Press $\Delta \nabla$ to cycle through the characters (A-Z, 0-9, -, *, +, — (space)) and stop when the desired character is indicated, then press \triangleright to enter. Enter the remaining characters the same way (maximum of 4). After entering all characters, press **OK**.

- The Confirmation screen appears.
- If you make a mistake, press \triangleleft until the incorrect character begins blinking. Then enter the correct character by pressing $\Delta \nabla$.

3

CLOSE CONFIRMATION SCREEN

Press **MENU**.

NOTE:

The characters available for the station name (ID) are A-Z, 0-9, -, *, +, — (space) (maximum of 4).

TV Station And ID List

STATION NAME	ID*
Anglia TV	ANGL
ARD	ARD
ARTE	ARTE
BBC Group	BBC
BBC1	BBC1
BBC2	BBC2
Berlin 1	BLN1
Berlin 2	BLN2
Border TV	BORD
Bayern1	BR1
Bayern3	BR3
BRT1	BRT1
BRT2	BRT2
Children Ch	CHLD
Canal +	CH+
CNN	CNN
Channel TV	CHNL
Central TV	CNTR
Channel 4	CH 4
Channel 5	CH 5
DRS	DRS
DR TV	DRTV
DSF	DSF
Euronews	EURN
Euronews	EURO
Eurosports	EURS
France1	FR1
France2	FR2
France3	FR3
Granada TV	GRNA
Grampian TV	GRMP
Hessen1	HR1
Hessen3	HR3
HRT	HRT
HTV	HTV
ITV Network	ITV
Kabelkanal	KABL
London	LNDN
MDR	MDR
MTV	MTV
Nord3	N3
NDR1	NDR1
NDR3	NDR3
NED1	NED1
NED2	NED2
NED3	NED3
Network 2	NET2
NRK	NRK
N-TV	N-TV
Offener Kanal	OKAN
ORF1	ORF1
ORF2	ORF2
ORF3	ORF3
OWL 3	OWL3
Premiere	PRMI
PR07	PR07
RAI1	RAI1
RAI2	RAI2
RAI3	RAI3
RB1	RB1
RB3	RB3
Rikisutvarpid-S	RKPS
RTBF 1	RTB1
RTBF 2	RTB2
RTE 1	RTE1
RTL	RTL
RTL 2	RTL2
RTP	RTP

STATION NAME	ID*
SAT	SAT
SAT 1	SAT1
Scottish TV	SCOT
SC4	SC4
SDR	SDR
SDR1	SDR1
SFB1	SFB1
SFB3	SFB3
SKY	SKY
Sky One	SKY1
Sky Net	SKYN
Sport	SPRT
SR 1	SR1
Super RTL	SRTL
STV Test	STVT
STV 1	STV1
STV 2	STV2
Suedwest3	SWR
SWF 1	SWF1
Schweiz4	SWZ4
TYNE TEES	TEES
Text	TEXT
TF1	TF1
TNT int	TNT
TRT int	TRT
TSI	TSI
TSR	TSR
TSW	TSW
TVE	TVE
TV Polonia	TVPA
TVP 1	TVP1
TVP 2	TVP2
TVS	TVS
TV2	TV2
TV5	TV5
Tele Zurich	TZUR
Ulster TV	ULST
Veronica	VERN
VIVA	VIVA
VIVA2	VIV2
VOX	VOX
VTM	VTM
VT4	VT4
West1	WDR1
West3	WDR3
YLE 1	YLE1
YLE 2	YLE2
Yorkshire TV	YORK
ZDF	ZDF
Zurich 1	ZUR1
3SAT	3SAT

* The "ID" abbreviation is what is shown on-screen in lieu of the station name. The "ID" abbreviation is listed in the Confirmation screen and is displayed on the TV screen each time the recorder is tuned to a different station.

TV Station Channel Number Guide

For customers in the U.K.

Only the main stations are listed. There are in addition many relay stations, and full lists are available from the BBC and ITV.

	BBC1	BBC2	ITV	CH4	CH5		BBC1	BBC2	ITV	CH4	CH5
London & South-East						North-West					
Bluebell Hill	40	46	43	65	—	Caldbeck	30	34	28	32	56
Crystal Palace	26	33	23	30	37	Winter Hill	55	62	59	65	48
Dover	50	56	66	53	—	North-East					
Heathfield	49	52	64	67	—	Bilsdale West Moor	33	26	29	23	35
Oxford	57	63	60	53	49	Chatton	39	45	49	42	—
South-West						Pontop Pike	58	64	61	54	68
Beacon Hill	57	63	60	53	—	Scotland					
Caradon Hill	22	28	25	32	—	Angus	57	63	60	53	—
Huntshaw Cross	55	62	59	65	67	Black Hill	40	46	43	50	37
Redruth	51	44	41	47	37	Sandale	22	—	—	—	—
Stockland Hill	33	26	23	29	—	Caldbeck	—	34	28	32	56
Channel Islands						Creigkelly	31	27	24	21	48
Fremont Point	51	44	41	47	—	Darvel	33	26	23	29	35
South						Durriss	22	28	25	32	67
Hannington	39	45	42	66	35	Eitshal	33	26	23	29	—
Midhurst	61	55	58	68	—	Keelylang Hill	40	46	43	50	—
Rowridge	31	24	27	21	—	Knock More	33	26	23	29	—
West						Rosemarkie	39	45	49	42	67
Mendip	58	64	61	54	37	Rumster Forest	31	27	24	21	—
East						Selkirk	55	62	59	65	52
Sandy Heath	31	27	24	21	39	Wales					
Sudbury	51	44	41	47	35	Blaenplwyf	31	27	24	21	56
Tacolneston	62	55	59	65	52	Carmel	57	63	60	53	—
Midlands						Llanddona	57	63	60	53	—
Ridge Hill	22	28	25	32	35	Moel-y-Parc	52	45	49	42	—
Sutton Coldfield	46	40	43	50	37	Presely	46	40	43	50	37
The Wrekin	26	33	23	29	35	Wenvoe	44	51	41	47	—
Waltham	58	64	61	54	35	Northern Ireland					
North						Brougher Mountain	22	28	25	32	—
Belmont	22	28	25	32	56	Divis	31	27	24	21	37
Emley Moor	44	51	47	41	37	Limavady	55	62	59	65	—

VIDEO Plus+® Setup

IMPORTANT

Normally, Auto Set Up (pg. 8), Preset Download (pg. 9) or Auto Channel Set (pg. 58) sets the Guide Program Numbers automatically. You need to set the Guide Program Numbers manually only in the following cases.

- When timer-programming with the VIDEO Plus+ system, the preset position, where the station you wish to record is received on your recorder, is not selected or when you add a channel after Auto Set Up or Auto Channel Set has taken place.
 - Set the Guide Program Number for that station manually.
- When you delete a channel or change preset positions manually after Auto Set Up or Auto Channel Set has taken place.
 - Set the Guide Program Numbers for all the receivable stations manually.
- When you wish to timer-record a satellite programme with the VIDEO Plus+ system.
 - Set the Guide Program Numbers for all satellite broadcasts received on your satellite receiver.

Turn on the TV and select the AV mode.

Guide Program Number Set

1

ACCESS MAIN MENU SCREEN

Press **MENU**.

2

ACCESS INITIAL SET SCREEN

Press Δ / ∇ to move the highlight bar (pointer) to "INITIAL SET", then press **OK** or \triangleright .

3

ACCESS GUIDE PROG SET SCREEN

Press Δ / ∇ to move the highlight bar (pointer) to "GUIDE PROG SET", then press **OK** or \triangleright .

4

ENTER GUIDE PROG NUMBER

Press Δ / ∇ or **NUMBER** keys to enter the Guide Program number for the desired station as shown in the TV listings. Then press **OK** or \triangleright .

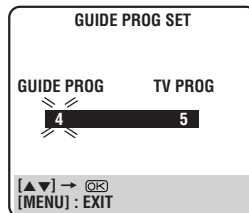

(Ex.) When inputting the Guide Program number 4 for CH4.

5

ENTER RECEIVING PRESET POSITION NUMBER

Press Δ / ∇ or **NUMBER** keys to input the number of the recorder's preset position on which the Guide Program number's broadcast is received. Then press **OK** or \triangleright .

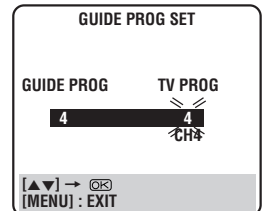

(Ex.) If CH4 is received on preset position 4.

- If the satellite broadcast is received on your recorder's auxiliary channel "L-1" or "L-2", select "L-1" or "L-2" for the channel position, depending on the connection to the satellite receiver (pg. 40).
- Repeat steps 4 and 5 as necessary.

6

RETURN TO NORMAL SCREEN

Press **MENU**.

Guide Program Number

"Guide Program (GUIDE PROG) number" refers to the assigned TV station numbers, according to broadcast area, for the VIDEO Plus+ timer recording. The Guide Program numbers can be found in most TV listings.

Clock Set

Turn on the TV and select the AV mode.

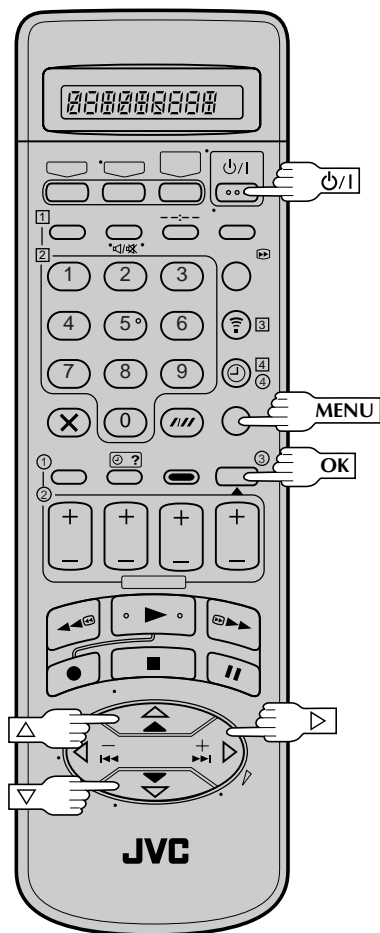

Just Clock

The Just Clock function provides accurate time keeping through automatic adjustments at regular intervals, by reading data from a PDC signal.

The Just Clock option can be set "ON" or "OFF" at the Clock Set screen (the default setting is "ON"). Press **OK** until the Just Clock setting begins blinking, then press $\Delta \nabla$ to change the setting.

IMPORTANT: If you turn the Just Clock function off, the accuracy of your recorder's built-in clock may be impaired, which could adversely affect timer recording.

IMPORTANT

If you performed Auto Set Up (pg. 8), Preset Download (pg. 9) or Auto Channel Set (pg. 58), without ever having set the clock previously, the recorder's built-in clock is also set automatically.

Perform the following steps only if —

— Auto Clock Set has not been performed correctly by Auto Set Up, Preset Download or Auto Channel Set.

or

— the recorder's memory backup has expired.

or

— you want to change Just Clock setting ("Just Clock" in the left column).

1 TURN THE RECORDER ON

Press power .

2 ACCESS MAIN MENU SCREEN

Press **MENU**.

3 ACCESS INITIAL SET SCREEN

Move the highlight bar (pointer) to "INITIAL SET" by pressing $\Delta \nabla$, then press **OK** or \triangleright .

4 ACCESS CLOCK SET SCREEN

Move the highlight bar (pointer) to "CLOCK SET" by pressing $\Delta \nabla$, then press **OK** or \triangleright . The Clock Set screen appears.

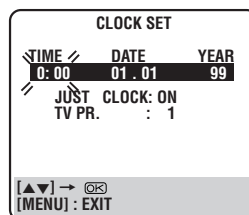
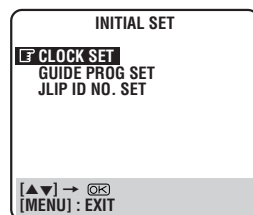

5 SET DATE AND TIME

Press $\Delta \nabla$ to set the time, then press **OK** or \triangleright . The "date" display begins blinking. Repeat the same procedure to set the date and year.

- When you set the time, press and hold $\Delta \nabla$ to change the time by 30 minutes.
- When you set the date, press and hold $\Delta \nabla$ to change the date by 15 days.

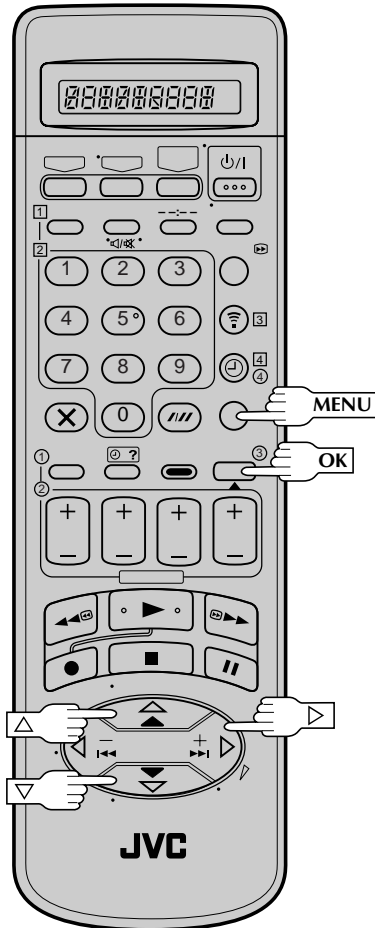

6

SET JUST CLOCK

The default setting is "ON". Set as desired by pressing Δ ∇ , then press **OK** or \triangleright .

- For the Just clock function, see "Just Clock" on page 66.
- If you set to "OFF", you can disregard the next step as you won't be able to receive regular clock adjustments.

7

SET CLOCK DATA SOURCE PRESET

The recorder is preset to receive clock setting and adjustment data from preset position 1. Press Δ ∇ to set the preset position to the number representing the station transmitting clock setting data (BBC1, BBC2, etc.), then press **OK** or \triangleright .

8

START CLOCK OPERATION

Press **MENU**.

NOTES:

- *Just Clock* (when set to "ON") adjusts the recorder's built-in clock every hour, except for 23:00, 0:00, 1:00 and 2:00.
- *Just Clock* is not effective when . . .
 - the recorder's power is on.
 - the recorder is in the *Timer* mode.
 - a difference of more than 3 minutes exists between the built-in clock's time and the actual time.
 - the recorder is in the *Auto Satellite Prog Rec* mode (see pg. 40).
- If *Just Clock* is set to "ON", the recorder's clock is automatically adjusted at the start/end of *Summer Time*.
- *Just Clock* may not function properly in poor reception conditions.

Questions And Answers

PLAYBACK

- Q. What happens if the end of the tape is reached during playback or search?**
 A. The tape is automatically rewound to the beginning.

- Q. Can the video recorder indefinitely remain in the still mode?**
 A. No. It stops automatically after 5 minutes to protect the heads.

- Q. When returning from multi-speed search to normal playback, the picture is disturbed. Should I be concerned about this?**
 A. No, it is normal.

- Q. Sometimes, during Index Search, the video recorder can't find the programme I want to see. Why not?**
 A. There may be index codes too close together.

RECORDING

- Q. When I pause and then resume a recording, the end of the recording before the pause is overlapped by the beginning of the continuation of recording. Why does this happen?**
 A. This is normal. It reduces distortion at the pause and resume points.

- Q. Can the video recorder indefinitely remain in the Record-Pause mode?**
 A. No. The video recorder shuts off automatically after 5 minutes to protect the heads.

- Q. What happens if the tape runs out during recording?**
 A. The video recorder automatically rewinds it to the beginning or, if Timer Recording, the cassette is ejected.

TIMER RECORDING

- Q. "⊙" and "⊖" remain lit on the display panel. Is there a problem?**
 A. No. This is a normal condition for a timer recording in progress.

- Q. Can I programme the timer while I'm watching a tape or a TV broadcast?**
 A. You won't see the picture as it is replaced by the on-screen menu, but the audio from the program or tape you're viewing can be heard.

- Q. Is it possible to timer-record a TV programme broadcast in 2000?**
 A. Yes, it is possible.

ATTENTION

This recorder contains microcomputers. External electronic noise or interference could cause malfunctioning. In such cases, switch the recorder off and unplug the mains power cord. Then plug it in again and turn the recorder on. Take out the cassette. After checking the cassette, operate the unit as usual.

Troubleshooting

Before requesting service for a problem, use this chart to see if you can correct the trouble yourself. Small problems are often easily corrected, and this can save you the trouble of sending your video recorder off for repair.

POWER

SYMPTOM	POSSIBLE CAUSE	CORRECTIVE ACTION
1. No power is applied to the recorder.	<ul style="list-style-type: none"> The mains power cord is disconnected. 	Connect the mains power cord.
2. The clock is functioning properly, but the recorder cannot be powered.	<ul style="list-style-type: none"> "⊖" is displayed on the display panel with Auto Timer set to "OFF". 	Press the ⊖ button to turn the "⊖" indicator off.
3. The remote control won't function.	<ul style="list-style-type: none"> The batteries are discharged. 	Replace the dead batteries with new ones.

TAPE TRANSPORT

SYMPTOM	POSSIBLE CAUSE	CORRECTIVE ACTION
1. The tape does not run during recording.	<ul style="list-style-type: none"> "⏏" is displayed on the display panel. 	Press PLAY to turn the "⏏" indicator off.
2. The tape will not rewind or fast-forward.	<ul style="list-style-type: none"> The tape is already fully rewound or fast-forwarded. 	Check the cassette.

PLAYBACK

SYMPTOM	POSSIBLE CAUSE	CORRECTIVE ACTION
1. The playback picture does not appear while the tape is running.	<ul style="list-style-type: none"> The TV receiver is not set to the AV mode. 	Set the TV to its AV mode.
2. Noise appears during visual search.	<ul style="list-style-type: none"> This is normal. 	
3. Noise appears during normal playback.	<ul style="list-style-type: none"> The automatic tracking mode is engaged. 	Try manual tracking (ⓘ pg. 36).
4. The playback picture is blurred or interrupted while TV broadcasts are clear.	<ul style="list-style-type: none"> The video heads may be dirty. 	Consult your JVC dealer.
5. Breaks are noticeable in Hi-Fi soundtrack.	<ul style="list-style-type: none"> Automatic tracking is engaged. 	Engage and adjust tracking manually (ⓘ pg. 36), or set the soundtrack to "NORM" (ⓘ pg. 39).

RECORDING

SYMPTOM	POSSIBLE CAUSE	CORRECTIVE ACTION
1. Recording cannot be started.	<ul style="list-style-type: none"> There is no cassette loaded, or the cassette loaded has had its Record Safety tab removed. 	Insert a cassette, or using adhesive tape, reseal the slot where the tab was removed.
2. TV broadcasts cannot be recorded.	<ul style="list-style-type: none"> "I-1", "L-1", "L-2", "F-1", "S-1" or "S-2" has been selected as the input mode. 	Set to the desired preset.
3. Tape-to-tape editing is not possible.	<ul style="list-style-type: none"> The source (another video recorder, camcorder) has not been properly connected. All necessary power switches have not been turned on. The input mode is not correct. 	<p>Confirm that the source is properly connected.</p> <p>Confirm that all units' power switches are turned on.</p> <p>Set the input mode to "I-1", "L-1", "L-2", "F-1", "S-1" or "S-2".</p>
4. Camcorder recording is not possible.	<ul style="list-style-type: none"> The camcorder has not been properly connected. The input mode is not correct. 	<p>Confirm that the camcorder is properly connected.</p> <p>Set the input mode to "I-1", "L-1", "L-2", "F-1", "S-1" or "S-2".</p>

TIMER RECORDING

SYMPTOM	POSSIBLE CAUSE	CORRECTIVE ACTION
1. Timer recording won't work.	<ul style="list-style-type: none"> ● The clock and/or the timer have been set incorrectly. ● The timer is not engaged. 	Re-perform the clock and/or timer settings. Press ⊖ and confirm that "⊖" is displayed on the display panel.
2. Timer programming is not possible.	<ul style="list-style-type: none"> ● Timer recording is in progress. 	Timer programming can't be performed while a timer recording is in progress. Wait until it finishes.
3. "⊖" and "⊖" on the display panel won't stop blinking.	<ul style="list-style-type: none"> ● The timer is engaged but there's no cassette loaded. 	Load a cassette with the Record Safety tab intact, or cover the hole using adhesive tape.
4. The cassette is automatically ejected, and "⊖" and "⊖" on the display panel won't stop blinking.	<ul style="list-style-type: none"> ● The loaded cassette has had its Record Safety tab removed. 	Remove the cassette and cover the hole with adhesive tape, or insert a cassette with the Record Safety tab intact.
5. "⊖" blinks for 10 seconds and the Timer mode is disengaged.	<ul style="list-style-type: none"> ● ⊖ has been pressed when there are no programs in memory, or the timer record information has been programmed incorrectly. 	Check the programmed data and re-programme as necessary, then press ⊖ again.
6. The cassette is automatically ejected, the power shuts off and "⊖" and "⊖" won't stop blinking.	<ul style="list-style-type: none"> ● The end of the tape was reached during timer recording. 	The programme may not have been recorded in its entirety. Next time make sure you have enough time on the tape to record the entire programme.
7. The VIDEO Plus+ system does not timer-record properly.	<ul style="list-style-type: none"> ● The recorder's preset positions have been set incorrectly. 	Refer to "Guide Program Number Set" and re-perform the procedure (Ⓞ pg. 65).

OTHER PROBLEMS

SYMPTOM	POSSIBLE CAUSE	CORRECTIVE ACTION
1. Whistling or howling is heard from the TV during camcorder recording.	<ul style="list-style-type: none"> ● The camcorder's microphone is too close to the TV. ● The TV's volume is too high. 	Position the camcorder so its microphone is away from the TV. Turn the TV's volume down.
2. When scanning channels, some of them are skipped over.	<ul style="list-style-type: none"> ● Those channels have been designated to be skipped. 	If you need the skipped channels, restore them (Ⓞ pg. 60).
3. The preset cannot be changed.	<ul style="list-style-type: none"> ● Recording is in progress. 	Press PAUSE to pause the recording, change presets, then press PLAY to resume recording.
4. Channel settings that were made manually seem to have changed or disappeared.	<ul style="list-style-type: none"> ● After the manual settings were made, Auto Channel Set was performed. 	Perform manual setting again.
5. No channels are stored in the recorder's memory.	<ul style="list-style-type: none"> ● The TV aerial cable was not connected to the recorder when Auto Set Up was performed. 	Connect the TV aerial cable to the recorder properly and turn off the recorder power once, then turn the recorder power back on again. The recorder will try Auto Set Up again (Ⓞ pg. 8).
6. The remote control won't operate the TV or satellite receiver.	<ul style="list-style-type: none"> ● The remote control brand setting is incorrect. 	Re-set the remote control to the correct brand (Ⓞ pg. 43, 44).

Error Code

Some error codes may appear on the TV screen when operating the recorder. Refer to the chart below for the solution.

ERROR CODE	SYMPTOM	SOLUTION
102	<ul style="list-style-type: none"> When a signal in which only the analog information is copy protected has been input for the dubbing in D-VHS mode. 	It is not possible to record a digitally copy protected signal.
103	<ul style="list-style-type: none"> When a signal which is digitally copy protected has been input for dubbing in D-VHS mode. 	It is not possible to record a digitally copy protected signal.
104	<ul style="list-style-type: none"> When a signal which cannot be digitally converted by the recorder has been recorded. 	Sometimes a programme can be recorded but not played back because the signal system is not supported by the recorder. Switch to analog input such as "L-1" to record.
105	<ul style="list-style-type: none"> When making an S-VHS/VHS recording of a signal from DV IN connector (i.Link). 	The recorder's DV IN connector (i.Link) is especially for D-VHS recording. The digital signal is not converted to analog and then recorded. Switch to analog input such as "L-1" to record.
200	<ul style="list-style-type: none"> When a signal which cannot be digitally converted by the recorder has been input and played back. 	Playback is impossible because a signal system not supported by the recorder has been input.
201	<ul style="list-style-type: none"> When normal playback is impossible such as with a mosaic (block-shaped noise). 	The recorder is making adjustments in order to display normal picture. Please wait.
205	<ul style="list-style-type: none"> When an attempt is made to play back a D-VHS recorded tape that has been found to be invalid. 	This tape cannot be played back by this recorder.
300	<ul style="list-style-type: none"> When a signal which cannot be digitally converted by the recorder has been input. 	Nothing can be seen or heard because the signal system is not supported by the recorder.

Index

FRONT VIEW

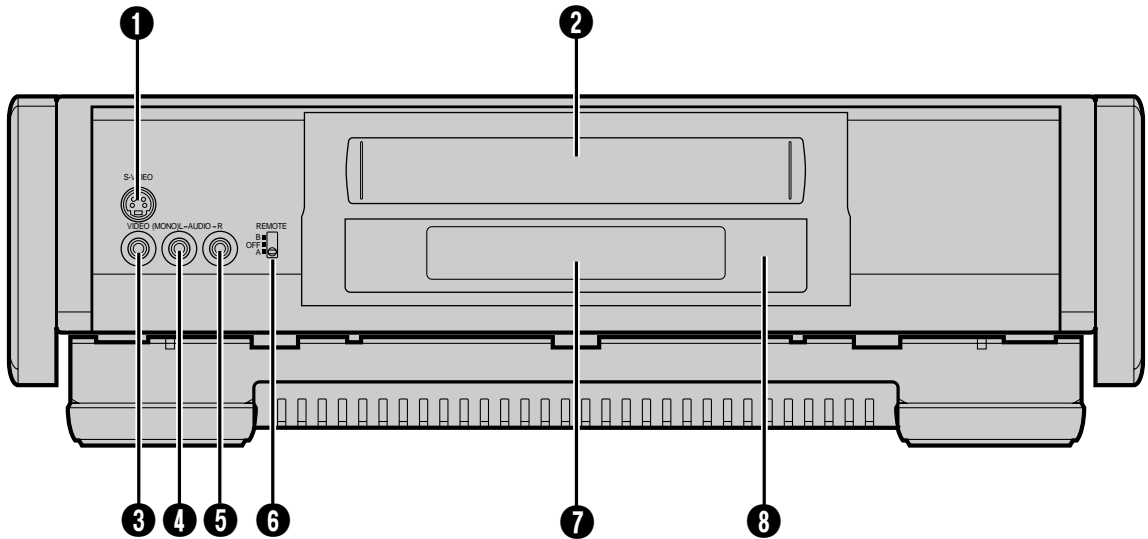

- ❶ **S-VIDEO Input Connector** enables S-VIDEO connection to camcorder or second recorder; input recordable when "S-2" selected. [☞](#) pg. 46
- ❷ **Cassette Loading Slot** is where cassette is inserted; door closes, "cassette loaded" indicator lights up on front display panel.
- ❸ **VIDEO Input Connector** enables easy connection of video output from another recorder or camcorder for editing; input recordable when "F-1" selected. [☞](#) pg. 46
- ❹ **AUDIO Input Connector [L]** enables easy connection of audio output (mono) from another recorder, camcorder or other source for editing. [☞](#) pg. 46
- ❺ **AUDIO Input Connector [R]** enables easy connection of audio output (Hi-Fi) from another recorder, camcorder or other source for editing. [☞](#) pg. 46
- ❻ **Remote Control Code Switch** enables setting of recorder to respond to A- or B-code control signals. [☞](#) pg. 42
- ❼ **Display Panel** provides clear view of various displays and indicators. [☞](#) pg. 76
- ❽ **Infrared Beam Receiving Window** is where remote control should be aimed when in use.

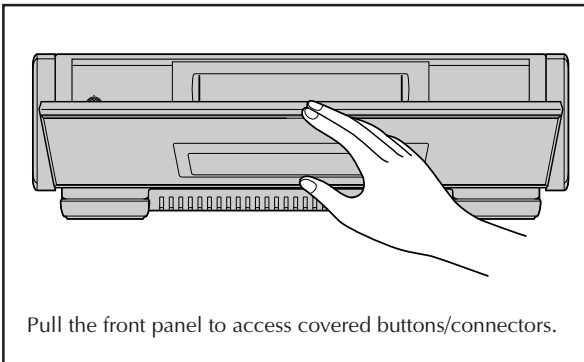

Pull the front panel to access covered buttons/connectors.

INSIDE VIEW OF FRONT PANEL

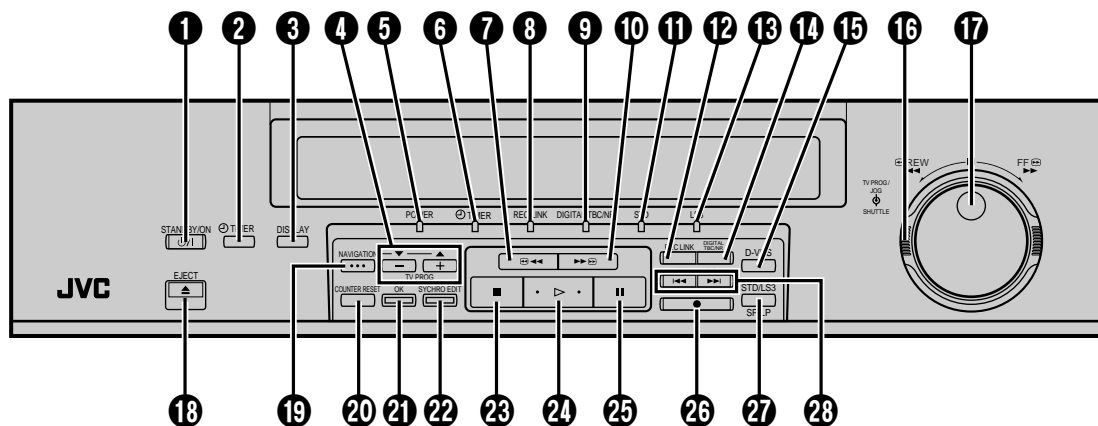

- ❶ **STANDBY/ON** \odot /I Button turns recorder on/off (loading a cassette also turns power on).
- ❷ **TIMER** Button engages timer-standby mode. \hookrightarrow pg. 19, 21
- ❸ **DISPLAY** Button switches display between clock time, tape remaining time, counter readings and preset position*. \hookrightarrow pg. 17
*Preset position is not displayed during playback.
- ❹ **TV PROG +/-** Buttons select a preset position. \hookrightarrow pg. 14
- ❺ **POWER** Indicator lights when the recorder is turned on.
- ❻ **TIMER** Indicator lights when \odot TIMER (or \odot on remote control) has been pressed to engage Timer mode. \hookrightarrow pg. 18, 19
- ❼ **Rewind [REW]** Button rewinds tape ; initiates high-speed reverse search. \hookrightarrow pg. 12, 13
- ❽ **REC LINK** Indicator lights up during Auto Satellite Prog Rec mode. \hookrightarrow pg. 41
- ❾ **DIGITAL TBC/NR** Indicator lights up during Digital TBC/NR. \hookrightarrow pg. 36
- ❿ **Fast Forward [FF]** Button fast-forwards tape; initiates high-speed forward search. \hookrightarrow pg. 12, 13
- ⓫ **STD** Indicator lights when the selected tape speed is "STD". \hookrightarrow pg. 14
- ⓬ **REC LINK** Button enables/disables the Auto Satellite Prog Rec mode. \hookrightarrow pg. 41
- ⓭ **LS3** Indicator lights when the selected tape speed is "LS3". \hookrightarrow pg. 14
- ⓮ **DIGITAL TBC/NR** Button enables/disables Digital TBC/NR. \hookrightarrow pg. 36
- ⓯ **D-VHS** Button enables/disables the D-VHS mode. \hookrightarrow pg. 14
- ⓰ **SHUTTLE** Ring performs forward and reverse slow-motion and search during Still or Play mode. \hookrightarrow pg. 13
- ⓱ **TV PROG** Dial scans to desired preset position during Stop mode. \hookrightarrow pg. 14
JOG Dial plays back frame by frame during Still or Play mode. \hookrightarrow pg. 13
- ⓲ **EJECT** Button ejects tape during Stop mode. \hookrightarrow pg. 12
- ⓳ **NAVIGATION** Button accesses title screen for tape navigation. \hookrightarrow pg. 24
- ⓴ **COUNTER RESET** Button resets counter to 0:00:00. \hookrightarrow pg. 17
- ⓵ **OK** Button enters selections made in on-screen menus. \hookrightarrow pg. 33
- ⓶ **SYNCHRO EDIT** Button enables Synchro Editing mode. \hookrightarrow pg. 51
- ⓷ **STOP** Button stops tape. \hookrightarrow pg. 12
- ⓸ **PLAY** Button plays back tape \hookrightarrow pg. 12; cancels Pause, Still, Slow, Search modes. \hookrightarrow pg. 13
- ⓹ **PAUSE** Button stops tape temporarily during recording \hookrightarrow pg. 14; stops tape temporarily during playback; plays back frame by frame with each additional press. \hookrightarrow pg. 13
- ⓺ **RECORD** Button starts regular recording (press once), Instant Timer Recording (press twice); sets duration of ITR. \hookrightarrow pg. 14 – 16
- ⓻ **STD/LS3** Button selects tape speed (in the D-VHS mode). \hookrightarrow pg. 14
SP/LP Button selects tape speed (in the S-VHS or VHS mode). \hookrightarrow pg. 14
- ⓼ **<< |<< and >> |>>** Buttons — same as $\triangleleft \triangleright$ Button on remote control \hookrightarrow pg. 13, 37

REAR VIEW

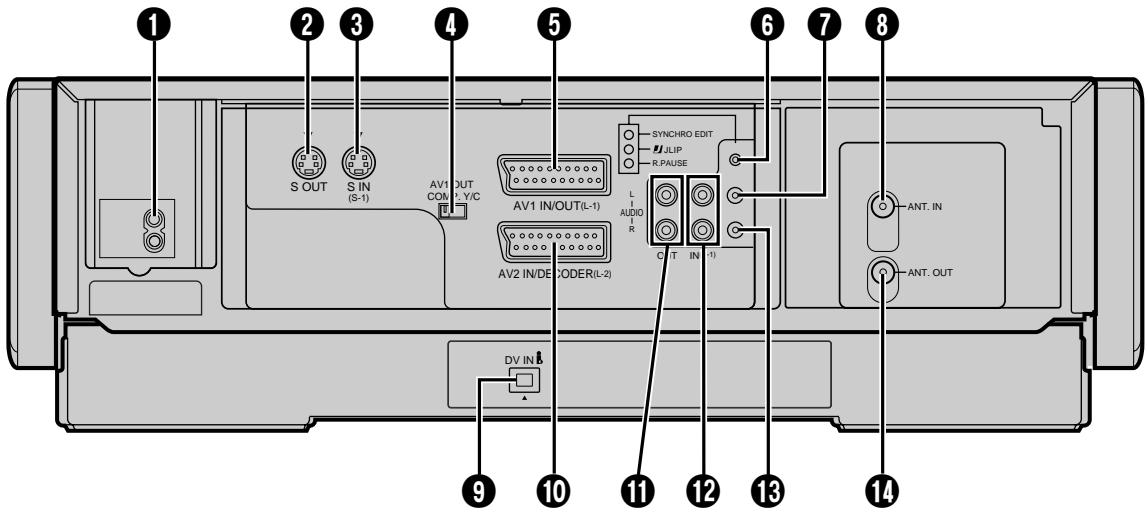

- ❶ **Mains Power Inlet** enables connection to a mains outlet using the provided Mains Power Cord. ☞ pg. 6, 7
- ❷ **S OUT Connector** enables S-VIDEO connection to TV or second recorder. ☞ pg. 7, 48
- ❸ **S IN Connector** enables S-VIDEO connection to camcorder or second recorder; input recordable when "S-1" selected. ☞ pg. 49
- ❹ **AV1 OUT Switch** selects the type of signal output via the 21-pin AV1 IN/OUT connector. ☞ pg. 6, 40
- ❺ **AV1 IN/OUT Connector** enables AV connection to TV or second recorder; input recordable when "L-1" selected. ☞ pg. 6, 48
- ❻ **SYNCHRO EDIT Connector** enables connection to camcorder equipped with LANC connector, for easy editing. ☞ pg. 51
- ❼ **J Terminal [JLIP (Joint Level Interface Protocol) Connector]** enables connection of a personal computer or similar device to allow computerized control of the recorder during editing and certain other operations. ☞ pg. 52
- ❽ **ANT. IN Connector** enables connection of aerial. ☞ pg. 6, 7
- ❾ **DV IN Connector (i.Link*)** enables connection to digital video devices; input recordable when "I-1" selected. ☞ pg. 47
* i.Link refers to the IEEE1394-1995 industry specification and extensions thereof. The  logo is used for products compliant with the i.Link standard.
- ❿ **AV2 IN/DECODER Connector** enables connection of satellite receiver, decoder or second recorder; input recordable when "L-2" selected. ☞ pg. 40, 48
- ⓫ **AUDIO OUT (L/R) Connectors** enable connection of audio cassette recorder, TV or second video recorder for dubbing. ☞ pg. 57
- ⓬ **AUDIO IN (L/R) Connectors** enable easy connection of audio output [mono (L) or Hi-Fi (R)] from another recorder, camcorder or other source for editing. ☞ pg. 46
- ⓭ **Remote PAUSE Connector** enables connection to JVC camcorder equipped with Master Edit Control, for easy editing. ☞ pg. 46
- ⓮ **ANT. OUT Connector** enables connection to aerial terminal of TV receiver. ☞ pg. 6, 7

DISPLAY PANEL

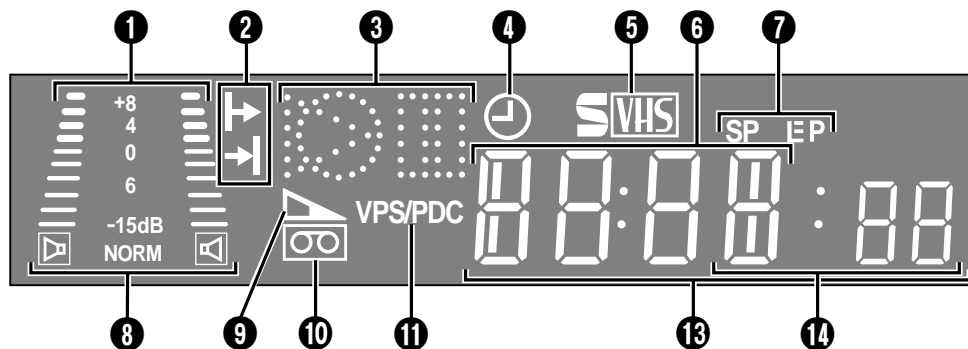

- ❶ **B.E.S.T. Picture System Display** lights from bottom to top while B.E.S.T. is active. [☞](#) pg. 34
- Audio Level Indicator** displays audio input and output levels.
- ❷ **Programme Time Indicators** show the programme start time (▶) and the programme stop time (▶) for timer-recording. [☞](#) pg. 20
- ❸ **Symbolic Mode Indicators**

PLAY: FF/REW VARIABLE SEARCH:		STILL:	
		SLOW:	
		RECORD:	
		RECORD PAUSE:	

- ❹ **"Timer" Indicator** lights when **TIMER** (or on remote control) has been pressed to engage Timer mode. [☞](#) pg. 19, 21
- ❺ **S-VHS Indicator** lights when a cassette marked S-VHS is inserted with S-VHS mode set to "AUTO", and when an S-VHS-recorded tape is played back. [☞](#) pg. 32, 33
- ❻ **Channel Display** shows preset position where the station currently being received is stored.
- Clock Display** shows current time. [☞](#) pg. 10
- ❼ **Tape Speed Indicators** display mode of recording; light during Record or Play mode. (in the S-VHS or VHS mode) [☞](#) pg. 14

*EP is only for NTSC playback.

- ❽ **Audio Mode Indicator** displays audio output mode currently selected. [☞](#) pg. 38, 39
- ❾ **Tape Remaining Time Indicator** displays time remaining on tape when certain buttons are pressed. [☞](#) pg. 17
- ❿ **"Cassette Loaded" Mark** lights once a cassette is inserted; remains lit until cassette ejected.
- ⓫ **PDC Indicator** lights when PDC has been engaged for timer recording. [☞](#) pg. 19, 21
- * VPS (Video Programme System) recording is not currently available in the U.K. and not possible with this recorder.
- ⓬ **VCR Indicator** lights when the video recorder is in the video mode. At this point, the TV automatically enters AV mode. [☞](#) pg. 12
- ⓭ **Counter** shows time elapsed since playback or recording began.*
- With displayed**, shows time remaining from current tape position to end of tape ([☞](#) pg. 17). Counter, Preset Position**, Clock and Tape Remaining Time Display appear alternately when **DISPLAY** (or on remote control) is pressed.
- * If the counter exceeds -20 hours (" $-20:00:00$ "), the display does not show the "-2" of " $-20:00:00$ ". In this case, confirm the counter on the TV screen.
- ** Preset Position is not displayed during playback.
- ⓮ **Mode** shows external input mode selected (I-1, L-1, L-2, F-1, S-1 or S-2).

REMOTE CONTROL

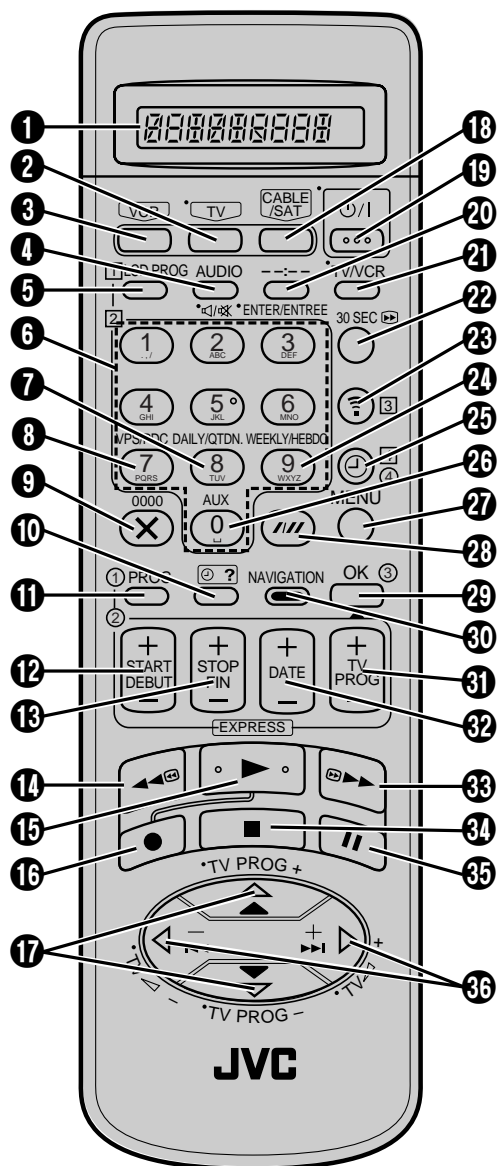

Buttons with a small dot on the left side of the name can also be used to operate your TV.

☞ pg. 43

- ❶ **LCD Panel** indicates which of the recorder, TV and satellite receiver the remote control can currently operate ☞ pg. 77; is used in the VIDEO Plus+ timer programming ☞ pg. 18.
 - ❷ **TV Button** enables remote control of connected TV. ☞ pg. 43, 77
 - ❸ **VCR Button** enables remote control of VCR or is used for switching A/B code of the remote control. ☞ pg. 42, 77
 - ❹ **AUDIO Button** changes output sound mode. ☞ pg. 38, 39
 - ❺ **🔊 (TV Muting) Button** mutes sound of connected TV. ☞ pg. 43
 - ❻ **LCD PROG Button** accesses the VIDEO Plus+ display on LCD panel. ☞ pg. 18
 - ❼ **NUMBER Keys** are used in preset position selection ☞ pg. 14, the VIDEO Plus+ timer programming ☞ pg. 18.
 - ❼ **DAILY Button** enables timer recording of daily serials. ☞ pg. 19, 21
 - ❸ **PDC Button** enables/disables PDC recording. ☞ pg. 19, 21
* VPS (Video Programme System) recording is not currently available in the U.K. and not possible with this recorder.
 - ❹ **X Button** cancels timer-programme. ☞ pg. 23
 - ❶ **0000 Button** resets counter to 0:00:00. ☞ pg. 17
 - ❶ **? Button** accesses Program screens/displays to check the programme that you have programmed (next programme's information screen/display appears each time button is pressed). ☞ pg. 22
 - ❶ **PROG Button** accesses the VIDEO Plus+ Program screen. ☞ pg. 18
 - ❶ **START +/- Button** accesses Regular Program screen; inputs programme Start Time. ☞ pg. 20
 - ❶ **STOP +/- Button** inputs programme Stop Time. ☞ pg. 20
 - ❶ **Rewind [REW] Button** — same as button on recorder. ☞ pg. 12, 13
 - ❶ **Play Button** — same as button on recorder. ☞ pg. 12, 13
 - ❶ **Record Button** — same as button on recorder. ☞ pg. 14
 - ❶ **△▽ Button** is used for selection in on-screen menus. ☞ pg. 33
- TV PROG +/-** selects the connected TV's/satellite receiver's channel. ☞ pg. 43, 44

- 18 **CABLE/SAT Button** enables remote control of connected satellite receiver. pg. 44, "Remote Control LCD" in the right column
- 19 **STANDBY/ON ψ /I Button** — same as button on recorder.
- 20 **--:-- (DISPLAY) Button** switches display between clock time, tape remaining time, counter readings and preset position*. pg. 17
*Preset position is not displayed during playback.
- 21 **TV/VCR Button** switches connected TV's mode between TV and AV. pg. 12
- 22 **30 SEC Button** initiates a 30-second period of fast-motion playback. pg. 37
- 23 **∞ Button** transmits entered the PlusCode number to the recorder. pg. 18
- 24 **WEEKLY Button** enables timer recording of weekly serials. pg. 19, 21
- 25 **\odot (TIMER) Button** — same as \odot **TIMER** button on recorder. pg. 19, 21
- 26 **AUX Button** selects recorder's auxiliary input mode. pg. 46, 48, 51
- 27 **MENU Button** accesses Menu screen. pg. 33
- 28 **Auto Tracking Button (///)** enables/disables auto tracking mode during playback pg. 36
- STD/LS3 (SP/LP) Button** selects tape speed. pg. 14
- 29 **OK Button** — same as button on recorder. pg. 33
- 30 **NAVIGATION Button** — same as button on recorder. pg. 24
- 31 **TV PROG +/- Button** — same as button on recorder. pg. 14
- 32 **DATE +/- Button** inputs date of programme for timer recording. pg. 20
- 33 **Fast Forward [FF] Button** — same as button on recorder. pg. 12, 13
- 34 **Stop Button** — same as button on recorder. pg. 12
- 35 **Pause Button** — same as button on recorder. pg. 13
- 36 **\triangleleft \triangleright Button** initiates functions such as Index Search pg. 37, variable-speed search, frame by frame playback. pg. 12
- TV \triangleleft +/- Button** controls volume of connected TV. pg. 43

How To Use

The remote control can operate most of your video recorder's functions, as well as basic functions of TV sets and satellite receivers of JVC and other brands.

(pg. 43, 44)

- Point the remote control toward the sensor window.
- The maximum operating distance of the remote control is about 8 m.

NOTES:

- When inserting the batteries, be sure to insert in the correct directions as indicated under the battery cover.
- If the remote control doesn't work properly, remove its batteries, wait a short time, replace the batteries and then try again.

Remote Control LCD

The remote control can operate not only the video recorder but also some of your TV and satellite receiver's functions. The LCD indicates which of these (VIDEO, TV or CABLE/SAT) the remote control can currently operate. When you first purchase the remote control, or after you have just replaced the batteries, VIDEO A (A code) is selected.

- 1 To operate your video recorder, first press the **VCR** button to set the remote control to the Video mode. To switch remote control's A/B code, refer to page 42.



- 2 To operate your TV, first press the **TV** button to set the remote control to the TV mode (pg. 43).



- 3 To operate your satellite receiver, first press the **CABLE/SAT** button to set the remote control to the Satellite receiver mode (pg. 44).



NOTES:

Even if "TV" is displayed on the LCD, the following operations can be performed without switching the mode.

- Basic operations for the recorder
After an operation is completed, "TV" reappears on the LCD.
- Express Timer Programming and VIDEO Plus+ Timer Programming operations
To perform a TV operation again, switch to TV mode first.
- Accessing main menu
To perform a TV operation again, switch to TV mode first.

A	
A/B Code	42
Audio Rec Mode	39
Auto Set Up	8
Auto SP → LP Timer	55
Auto Timer	55
Automatic Satellite Programme Recording	40
Aux Input	46
B	
B.E.S.T. Picture System	34
C	
Cancel Timer Programme	23
Change Station Channel Position	61
Check Timer Programme	22
Clock Setting	66
Connection To Satellite Receiver	40
D	
Delete Channel	61
Digital 3R	36
Digital TBC/NR	36
Direct Rec	11
D-VHS Recording	14
DV Sound Setting	47
E	
Editing	45
Elapsed Recording Time	17
Express Timer Programming	20
F	
Fine Tuning	61
Frame-By-Frame Playback	13
G	
Guide Program Number Setting	65
H	
High-Speed (Turbo) Search	13
I	
Index Search	37
Instant Timer Recording (ITR)	16
J	
JLIP Terminal	52
Just Clock	66
M	
Manual Channel Setting	60
Manual Tracking	36
Multi-Brand Remote Control	43, 44
N	
Next Function Memory	55
O	
On-Screen Display	53
P	
PDC	19
Picture Control	45
Power Save	54
Preset Download	9
R	
Recording	14
Record One Programme While Watching Another	16
Remote Control LCD	18, 77
Repeat Playback	56
Replace Timer Programme	22
S	
Set Stations	62
Skip Search	37
Slow Motion Playback	13
Soundtrack Selection	39
Still Picture Playback	13
S-VHS (Super VHS)	32
S-VHS/VHS Recording	15
Synchro Editing	51
T	
Tape Position Indicator	12
Tape Remaining Time	17
Tuner Setting	58
T-V Link	11
TV Station And ID List	63
V	
Variable-Speed Search	13
Video Navigation	24
Delete Data	28, 29
Navigation	24
Sorting By Category	31
Sorting By Date	31
Sorting By Tape Number	30
Title Editing	26
VIDEO Plus+® Setup	65
VIDEO Plus+® Timer Programming	18

SPECIFICATIONS

HM-DR10000EK

GENERAL

Power requirement	: AC 220 – 240 V~, 50/60 Hz
Power consumption	
Power on	: 36 W
Power off	: 8.7 W
Temperature	
Operating	: 5°C to 40°C
Storage	: -20°C to 60°C
Operating position	: Horizontal only
Dimensions (WxHxD)	: 468 x 145 x 369 mm
Weight	: 8.0 kg
Maximum recording time	
D-VHS (STD)	: 420 min. with DF-420 video cassette
D-VHS (LS3)	: 1260 min. with DF-420 video cassette
S-VHS/VHS (SP)	: 240 min. with E-240 video cassette
S-VHS/VHS (LP)	: 480 min. with E-240 video cassette

VIDEO/AUDIO (D-VHS)

Format	: MPEG2 standard mode
Track composition	
Tape speed	: 16.67 mm/sec (STD mode) 5.56 mm/sec (LS3 mode)
Head azimuth	: ±30 deg
Drum rotation	: 1800 rpm
Tracking system	: CTL track system
Recording specification	
Main data input rate	: 14.1 Mbps (STD mode) 4.7 Mbps (LS3 mode)
Sub data input rate	: 0.146 Mbps (STD mode) 48.7 Kbps (LS3 mode)
Recording rate	: 19.14 Mbps
Track structure	: 1 Sector
Length of sync block	: 112 bytes
Inner ECC	: RS code
Outer ECC	: RS code
Code word shuffling	: 6 tracks
Modulation system	: SI-NRZI

VIDEO/AUDIO

Format	: S-VHS/VHS PAL standard
Signal system	: PAL-type colour signal and CCIR monochrome signal, 625 lines/50 fields
Recording system	: DA4 (Double Azimuth) helical scan system
Signal-to-noise ratio	: 45 dB
Horizontal resolution	: 250 lines (VHS) 400 lines (S-VHS)
Frequency range	: 70 Hz to 10,000 Hz (Normal audio) 20 Hz to 20,000 Hz (Hi-Fi audio)

CONNECTOR

Input/Output	: 21-pin SCART connectors (IN/OUT x 1, IN/DECODER x 1) RCA connectors (VIDEO IN x 1, AUDIO IN x 2, AUDIO OUT x 1) S-Video connectors (IN x 2, OUT x 1) DV connector : IN x 1 (4-pin, IEEE1394 conformity, digital input)
--------------	---

TUNER/TIMER

TV channel storage capacity	: 99 positions (+AUX position)
Tuning system	: Frequency synthesized tuner
Channel coverage	: VHF 44.5 – 143/143 – 470 MHz UHF 470 – 862 MHz
Memory backup time	: Approx. 60 min.

ACCESSORIES

Provided accessories	: RF cable, S-Video cable, 21-pin SCART cable, DV cable, Power cord, Infrared remote control unit, "AA" battery x 2
----------------------	---

Specifications shown are for SP mode unless otherwise specified.

E. & O.E. Design and specifications subject to change without notice.

JVC

VICTOR COMPANY OF JAPAN, LIMITED