

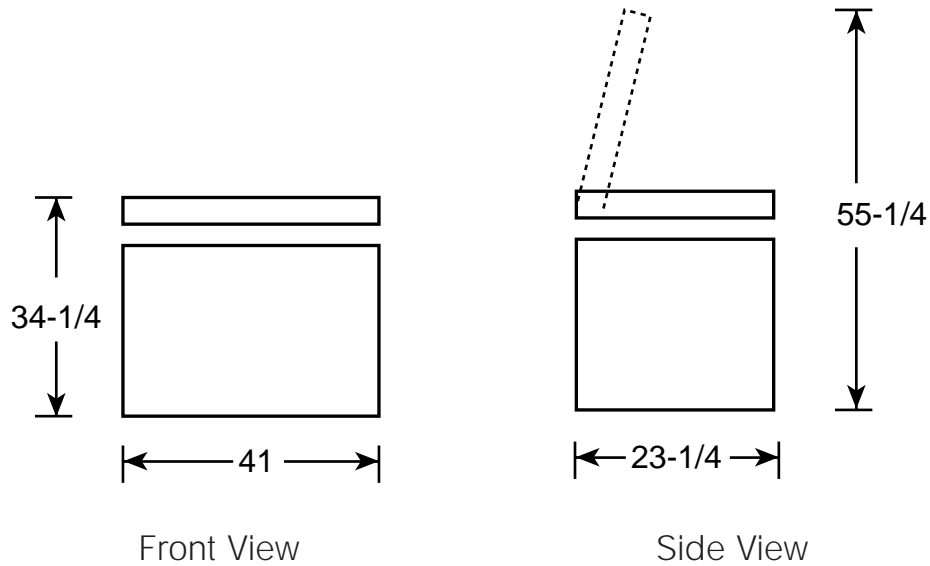

GE Appliances

FCM9SAWH—Chest Freezer

Dimensions (in inches)



Air Clearances	
Each side (in.)	3
Back (in.)	3

For answers to your Monogram®,
 GE Profile Performance Series™,
 GE Profile™ or GE appliance questions, call
 GE Answer Center® service, 800.626.2000.



Total volume and shelf
 area are calculated by the
 Association of Home
 Appliance Manufacturers'
 standards.



Listed by
 Underwriters
 Laboratories



GE Appliances

FCM9SAWH—Chest Freezer

Features and Benefits

- 8.8 cu. ft. Capacity
- Manual Defrost
- Adjustable Temperature Control
- Defrost Drain
- Limited Food Loss Warranty
- Model FCM9SAWH—White