

Parts diagram

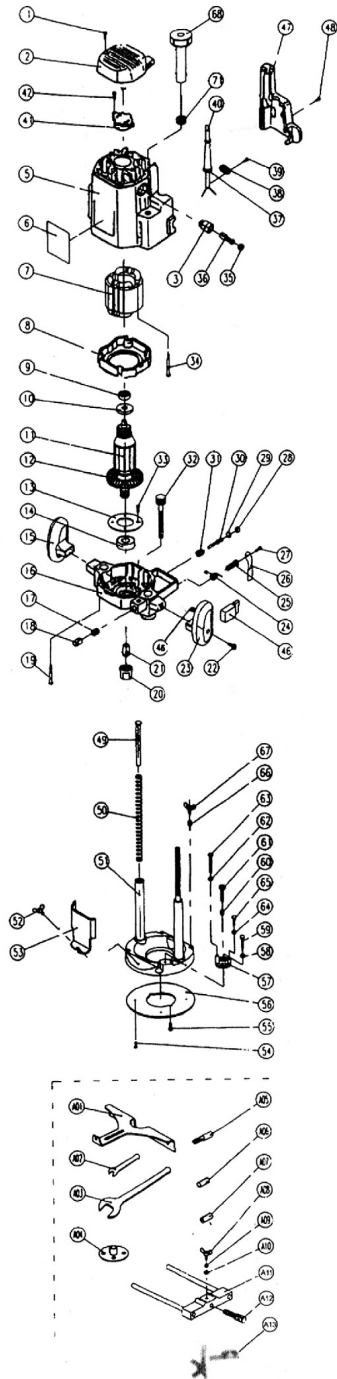

Guarantee

Your Lucas Power Tool is a quality product made to high manufacturing standards. It is guaranteed for domestic use against manufacturing defects for a period of 36 months from the date of purchase.

To claim this extended warranty you need to register on our website. If your product fails due to a defect in material or construction during this period, return it to the store that you purchased it at. This extended guarantee does not affect your statutory rights.

Wear and tear that is caused by normal working - including accessories - is not covered by this guarantee. The guarantee is valid for 12 months if the product is used for occasional professional use. Overload, neglect of cleaning or maintenance, improper use or unauthorised repair invalidates the guarantee. Heavy duty, regular professional usage is not covered by the guarantee.

We reserve the right to change specifications without prior notice.

LPT- PR0312-RE/010821/1

Lucas Power Tools Limited
24, Grays Inn Road, London,
WC1X 8HP, United Kingdom.

www.lucaspowertools.com

LPT-PR0312

Plunge Router



- GB** Plunge Router
- DE** Oberfräse
- ES** Fresadora electrónica modelo
- FR** Défonceuse à piston
- IT** Fresatrice verticale



Operating Instructions



General safety precautions

Note: To reduce the risk of injury, fire, and related accidents, follow these IMPORTANT safety tips.

1. Keep work area clear.
2. Do not use electric power tools in wet or very damp locations, near flammable materials, or combustible gasses.
3. Keep children away from the work area when using electric power tools.
4. When not in use, electric power tools should be stored in a dry location and locked away to avoid accidental or unqualified use.
5. Do not over-work power tools. Stay within the limits of the workload capacity of each tool.
6. Do not operate power tools while wearing loose clothing. Wear proper work clothes, shoes, headgear, and gloves.
7. Wear safety glasses at all times and a face mask to avoid inhalation of fine dust.
8. Properly maintain the mains power cable. Inspect for fraying or loose insulation or damaged plugs. Do not pull the mains cable out of the socket by pulling on the cable. Keep cord away from caustic chemicals, high temperatures, and sharp objects. Do not carry the tool by the mains power cable.
9. Ensure that all work pieces are properly anchored or clamped down before using electric power tools.
10. Adopt a comfortable working position when operating power tools to avoid slipping.
11. Inspect router bits before each use. Do not use bits that are dull or that have damaged cutting edges. Unplug tool before installing or changing router bits. Unplug tool when not in use.
12. Inspect tools before using for loose guides, or other parts. Tighten where necessary.
13. Remember to remove adjustment tools and wrenches before using.

14. Unplug tool before performing regular maintenance and cleaning.
15. Keep your mind on the job at hand and stay alert. Never operate power tools while tired or under the influence of alcohol, drugs or medication.

Specific Safety Precautions

Note: To reduce the risk of injury, fire, and related accidents, follows these IMPORTANT safety tips

1. Router bits are very sharp. Use gloves when inserting and removing bits.
2. Examine each router bit carefully before using. Replace cracked, damaged, or dull bits, and dispose of them safely.
3. Check over the work piece to ensure it is free from nails or screws. The router bit rotates at 22,000 rpm and can shatter if it encounters foreign particles, which can cause serious injury.
4. Hold the router tightly with both hands when in use.
5. Keep hands and clothes away from rotating components.
6. Be careful to keep the router bit clear of any objects or work pieces before starting the router. Ensure that the router is up to speed before engaging the work piece. If the router bit shows signs of 'wobbling', carefully re-insert it before using.
7. Check for correct feed direction (see diagram)
8. The Lucas Plunge Router is equipped with a safety switch button on the right handle. To operate, depress the safety switch then pull back on the trigger. To turn off, simply release the trigger.
9. During use, the router bit can become very hot. Use care and allow a few minutes for it to cool down before removing or changing the bits.

Using your Lucas Plunge Router

Before attempting to insert or remove a router bit, unplug the tool from the wall socket.

1/2" shaft router bit: (see Fig. 1)

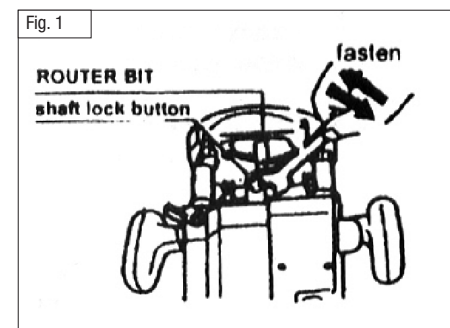

Insert the router bit into the cone-shaped collet chuck as deep as possible, then pull it out slightly (about 1/16"). Depress the shaft lock button to lock the shaft while you tighten the collet chuck with the wrench (included).

1/4" and 3/8" router bit

For router bits with a 1/4" or 3/8" shaft, first insert the corresponding collet adapter (included).

Then insert the bit into the adapter. Depress the shaft lock button to lock the shaft while you tighten the collet chuck with the wrench (included).

Reverse the above procedure to remove the bits

Setting the plunge depth

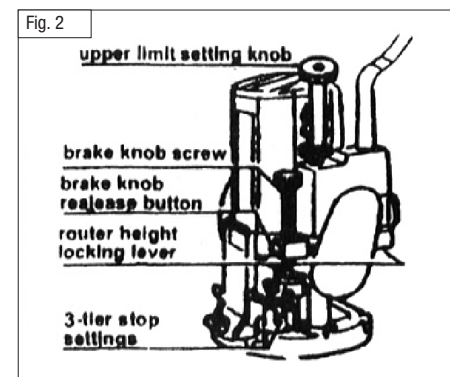

1. Install the desired plunge bit
2. Unlock (lift) the router height locking lever next to the right handle
3. Raise the motor housing by slacking off the large upper limit setting knob (Fig. 3) to a height that allows the base of the bit to be just slightly higher than the base of the router.
4. Place the router on a solid, flat surface.
5. Lower the router until the tip of the router bit is in contact with a flat surface, and then lock down the router height-locking lever.
6. Lower the brake knob screw until it presses firmly against the shortest of the three stop settings (note: press the brass brake knob release button to allow it to turn more freely).
7. **Note:** the brake knob screw aligns with the measurement gauge on the side of the housing.
8. Use the measurement gauge to raise the brake knob a distance equal to the total depth desired. (Note: the total plunge depth must not exceed the length of the cutting edge of the router bit.)

Safety note

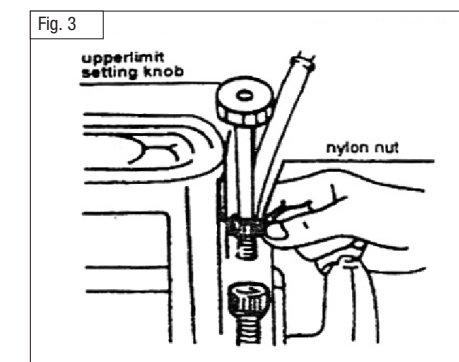

On any one pass, the maximum plunge depth must not exceed 9/16" or 15mm. The 3-tier safety stop assembly is preset to keep each plunge depth within the maximum. If the desired plunge depth is greater than 9/16" or 15mm, simply rotate the stop setting until the tallest stop is aligned just beneath the base of the brake knob screw.

After the first pass, rotate the stop setting to the next tallest stop and continue until the desired depth is achieved.

Regulate the upper limit of the router body by rotating the upper limit knob. The ideal upper limit is when the base of the router bit just clears the router base when the router height locking level is released.

Safety note

1. Do not raise the upper limit above the position described above.
2. Before operating the router, make sure it can automatically ascend to the upper limit referred to above.
3. Excessive cutting depth leads to motor overload and drag on the shaft. Limit each pass to a maximum depth of 9/16" or 15mm. Make multiple passes to achieve the desired results. The maximum total plunge depth for this router is 2".
4. Use appropriate router bits for the job. Never attempt a plunge cut deeper than the length of the cutting edge of the bit.
5. Make sure the shaft lock button is fully released and the shaft rotates freely before each use.

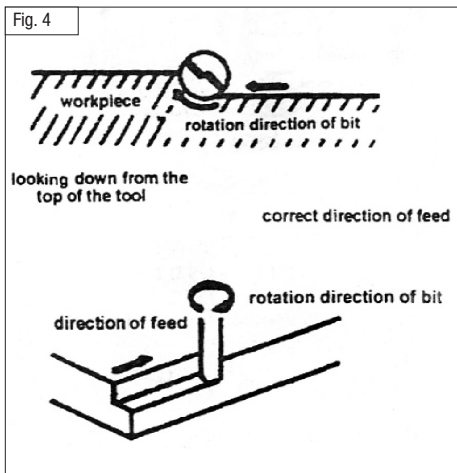

Operation

Place the router base on the work piece while keeping the bit free and away from the material. Switch the tool on and wait until it reaches full speed. The work piece must be securely anchored. The work piece must be on the left side of the router bit when looking in the direction of the feed for the edge to be cut (Fig.4).

Cutting tips: Guide the router slowly and evenly to obtain a quality cut and to avoid overloading the tool. Keep moving the tool to avoid burning or discolouring of the wood surface. Proper speed depends on the size of the bit, the type of wood, and the cutting depth. You may want to experiment on a similar piece of waste wood first, to get some practical experience.

When using a straight-line trim guide, install it on the right side of the router. Keep the edge of the work piece in view by looking in the direction of the feed.

STRAIGHT-LINE GUIDE:

Use the straight-line guide for optimum straight plunge cuts (Fig.5).

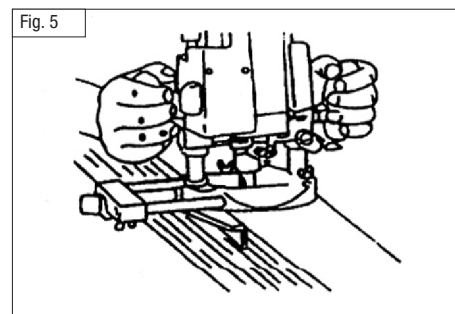

Attach the straight-line guide to the base module guide mount with the wing nut (B); loosely tighten. Attach the base module guide mount to the router base by sliding the two parallel rods through the corresponding opening in the router base; loosely tighten all three wing nuts (A). Slide the guide module in or out to achieve the desired distance between the router bit and the straight guide before tightening wing nuts (A). To make fine adjustments, turn the trimming screw knob, then tighten wing nut (B) (Fig. 6).

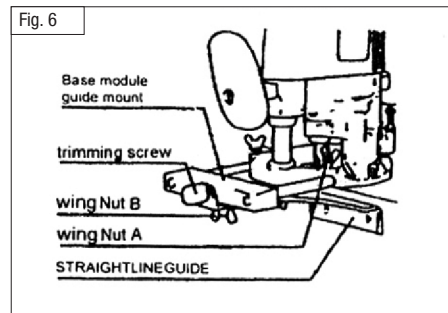

If desired, you can extend the straight-line guide by attaching straight pieces of hardwood to each arm of the guide. Remember to leave a sufficient opening for the router bit to work and for an unobstructed view of the cutting area.

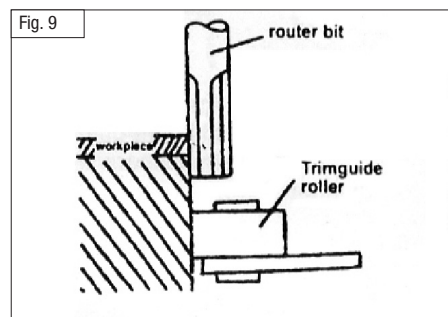
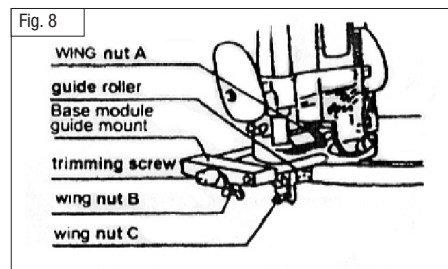
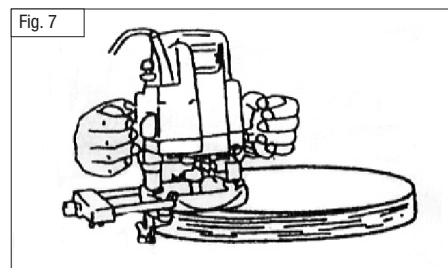

TRIM-GUIDE:

Use the trim guide for optimum curve cutting or trimming. The guide roller ensures perfectly contoured cuts.

Attach the trim guide to the base module guide mount with the wing nut (B); loosely tighten. Attach the base module guide to the router base in the same way described above for the straight guide. Slide the guide module in or out to achieve the desired distance between the router bit and the trim guide roller before tightening the three wing nuts (A). Fine-tune the distance by turning the trimming screw knob; tighten wing nut (B). Adjust the height to the trim guide roller using wing nut (C) (Fig.7/8/9).

Note: check that the trim guide roller is positioned to roll along the edge of the work piece correctly. Check that all wing nuts are tightened to prevent slippage.

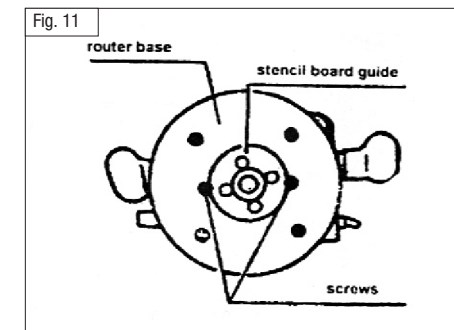
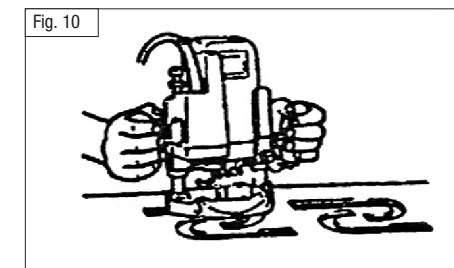

STENCIL BOARD GUIDE:

The stencil board guide provides a sleeve for the router bit so that the router can move easily within the stencil guide (Fig. 10/11).

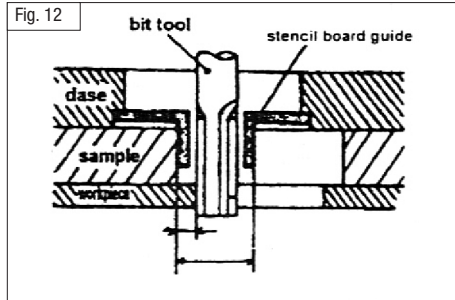

To install the stencil board loosen the two screws in the base. Drop in the stencil board guide and refasten the two screws.

Clamp or nail the stencil to the work piece, then slide the stencil while simultaneously moving the tool (Fig. 12).

MAINTENANCE:

Always unplug the tool before cleaning and performing any maintenance. After using, clean dust from the tool before storing in a dry, cool place.

To clean the tool casing, use only a damp (not wet) cloth with mild soap if required. Do not use solvents. Do not allow water to enter the tool.

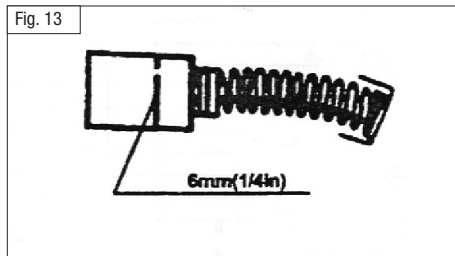
**Checking and replacing carbon brushes.**

Check the carbon brushes for wear and replace if worn down to a thickness of 6mm/1/4". Always replace both brushes simultaneously (Fig. 13).

To replace brushes, remove the plastic brush holder cover with a slotted screwdriver. Remove the old brushes and thoroughly clean out the brush apertures. Replace with new brushes and then screw the brush cover back in. Do not over tighten (Fig. 14).

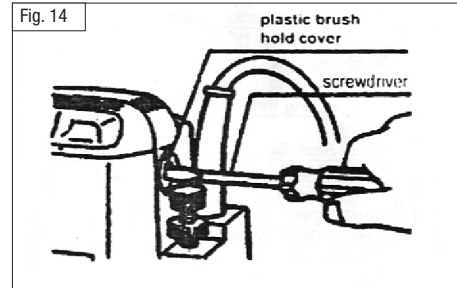

Note: it will be necessary to completely unscrew and remove the upper limit-setting knob on the right side of the router to access the brush cover on that side. To do this, lock (push down on) the router height locking lever before unscrewing and removing the upper limit setting knob. When done, reverse the above procedure.

TECHNICAL DATA

Main voltage	V 240
Main frequency	Hz 50
Power input	w 1800
No load speed	min 22000

No.	Part Name	Qty	No.	Part Name
1	Pan Head Screw	2	45	Switch Safety Button
2	Tall cap	1	46	Trigger Switch
3	Brush housing	2	47	Switch Compartment Housing Cover
5	Housing	1	48	Housing Screw
6	Name Plate	1	49	Pin
7	Stator	1	50	Spring
8	Shield	1	51	Base Module
9	Bearing 629	1	52	Screw M5x10
10	Insulation Washer	1	53	Plastic Shield
11	Motor	1	54	Screw M4x10
12	Fan	1	55	Screw M5x10
13	Bearing Support	1	56	Base Plate
14	Bearing 6004	1	57	3-Tier Safety Stop
15	Left Handle	1	58	Nut for Hexagon Socket HD
16	Motor Support	1	59	Screw for Hexagon Socket HD
17	Spring	1	60	Spring
18	Brake Knob Release Button	1	61	Screw M6x30
19	Screw M5x40	4	62	Nut for Hexagon Socket HD
20	Collet Chuck	1	63	Screw for Hexagon Socket HD
21	Collet Sleeve	1	64	Nut for Hexagon Socket HD
22	Screw M5x40	2	65	Screw for Hexagon Socket HD
23	Right Handle	1	66	Spring
24	Spring	1	67	Screw M5X10
25	Clamping Screw	1	68	Upper Limit Setting Knob
26	Router Height Locking Lever	1	71	Nylon Nut
27	Hexagon Socket HD Screw	1	73	Cover Plate
28	Shaft Lock Button Cap	1	A01	Straight Line Guide
29	Retaining Ring	1	A02	Stop Setting Wrench
30	Shaft Locking Pin	1	A03	Collet Wrench
31	Spring	1	A04	Stencil Board Guide
32	Brake Knob Screw	1	A05	Straight Router Bit
33	Screw M4x10	4	A06	Collet Adapter
34	Screw M5x45	2	A07	3/8" Collet Adapter
35	Brush Cover	2	A08	Screw M6x12
36	Carbon Brush & Spring Assembly	2	A09	Spring Washer 6
37	Cord Shield	1	A10	Flat Washer 6
38	Clip	1	A11	Base Module Guide Mount
39	Screw ST4.2x16	2	A12	Trimming Screw
40	Cord	1	A13	Trim Guide with Roller
41	Bearing Housing	1		
42	Screw ST4.2x16	2		