

Chromalox[®]

Installation, Operation and RENEWAL PARTS IDENTIFICATION

Type DU-RAD Electric Radiant Heater

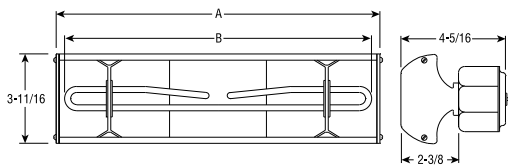

Single Element

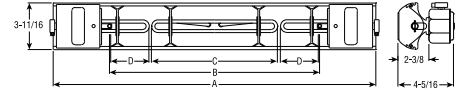

Three Elements

SERVICE REFERENCE

DIVISION 4

SECTION DU-RAD

SALES REFERENCE (Supersedes PG423)

PG423-1

161-057863-001

DATE MARCH, 2004

Specifications – Table A

Model	Volts	kW	Dimensions (In.)				
			A Overall	B Total Heated	C Center Heated	D End Heated	
One Double-Hairpin Element Models							
DU-RAD-040	120, 208	1.60	20 ³ / ₈	18 ¹ / ₁₆	—	—	
DU-RAD-048	240 or 275	1.97	23 ²⁵ / ₃₂	22 ²⁵ / ₃₂	—	—	
DU-RAD-058	120, 208	2.44	28 ⁷ / ₈	27 ²⁵ / ₃₂	—	—	
DU-RAD-066	240, 275	2.82	33 ¹ / ₄	31 ²⁹ / ₃₂	—	—	
DU-RAD-074	or 480	3.19	37 ¹ / ₄	35 ²⁹ / ₃₂	—	—	
DU-RAD-082	208,	3.57	41 ¹ / ₈	39 ¹ / ₈	—	—	
DU-RAD-090		3.95	45 ³ / ₈	43 ³ / ₈	—	—	
DU-RAD-0102	240,	4.52	51 ¹ / ₈	49 ¹ / ₈	—	—	
DU-RAD-0112		4.99	56 ³ / ₈	54 ⁷ / ₈	—	—	
DU-RAD-0124	275	5.56	62 ¹ / ₂	60 ¹⁵ / ₁₆	—	—	
DU-RAD-0136		6.13	68 ⁹ / ₁₆	66 ¹⁵ / ₁₆	—	—	
DU-RAD-0148	or	6.70	75 ¹ / ₂	72 ⁹ / ₁₆	—	—	
DU-RAD-0156		7.10	78 ¹³ / ₁₆	77	—	—	
DU-RAD-0164	480	7.45	82 ¹¹ / ₁₆	81	—	—	
DU-RAD-0172		7.83	87	85 ¹ / ₁₆	—	—	
Three Hairpin Element Models							
DU-RAD-240	120, 208 240 or 275	3.20	44 ³ / ₄	35 ⁷ / ₈	19 ¹ / ₄	8 ⁵ / ₁₆	
DU-RAD-248		3.57	48 ³ / ₄	39 ³ / ₈	23 ¹ / ₄	8 ⁷ / ₁₆	
DU-RAD-258		4.04	53 ³ / ₄	45	28 ³ / ₈	8 ⁷ / ₁₆	
DU-RAD-266		4.42	57 ³ / ₄	49	32 ³ / ₈	8 ⁵ / ₁₆	
DU-RAD-274	208, 240 or 275	4.79	62	53 ¹ / ₈	36 ¹ / ₂	8 ⁵ / ₁₆	
DU-RAD-282		5.17	66 ¹ / ₈	57 ¹ / ₈	40 ⁹ / ₁₆	8 ⁷ / ₁₆	
DU-RAD-290		5.55	70 ⁹ / ₁₆	61 ⁹ / ₁₆	44 ¹ / ₁₆	8 ⁷ / ₁₆	
DU-RAD-2102		6.12	76 ⁹ / ₁₆	67 ⁹ / ₁₆	50 ¹ / ₁₆	8 ⁷ / ₁₆	
DU-RAD-2112		6.59	81 ⁵ / ₁₆	72 ¹ / ₁₆	55 ¹³ / ₁₆	8 ⁷ / ₁₆	
DU-RAD-2124		7.16	87 ¹ / ₂	78 ³ / ₈	62	8 ⁵ / ₁₆	
DU-RAD-2136		7.73	93 ¹ / ₂	84 ³ / ₈	68	11 ⁷ / ₁₆	
DU-RAD-2148		8.30	99 ³ / ₈	90 ³ / ₄	74 ¹ / ₈	8 ⁵ / ₁₆	
DU-RAD-2156		8.70	103 ¹¹ / ₁₆	94 ¹³ / ₁₆	78 ³ / ₈	8 ⁵ / ₁₆	
DU-RAD-2164		9.05	107 ¹⁵ / ₁₆	98 ¹⁵ / ₁₆	82 ³ / ₈	8 ⁵ / ₁₆	
DU-RAD-2172		9.43	112	103 ¹ / ₈	86 ¹ / ₂	8 ⁷ / ₁₆	
DU-RAD-340		120, 208 240 or 275	3.80	51	42 ¹ / ₈	19 ¹ / ₄	11 ⁷ / ₁₆
DU-RAD-348			4.17	55	46 ¹ / ₈	23 ¹ / ₄	11 ⁷ / ₁₆
DU-RAD-358			4.64	60 ¹ / ₈	51 ¹ / ₄	28 ³ / ₈	11 ⁷ / ₁₆
DU-RAD-366			5.02	64 ¹ / ₈	55 ¹ / ₄	32 ³ / ₈	11 ⁷ / ₁₆
DU-RAD-374			5.39	68 ¹ / ₄	59 ³ / ₈	36 ¹ / ₂	11 ⁷ / ₁₆
DU-RAD-382	5.77		72 ⁵ / ₈	63 ³ / ₈	40 ⁹ / ₁₆	11 ⁷ / ₁₆	
DU-RAD-390	6.15		76 ⁷ / ₁₆	67 ⁹ / ₁₆	44 ¹¹ / ₁₆	11 ⁷ / ₁₆	
DU-RAD-3102	6.72		82 ⁷ / ₁₆	73 ⁹ / ₁₆	50 ¹¹ / ₁₆	11 ⁷ / ₁₆	
DU-RAD-3112	7.19	87 ⁹ / ₁₆	78 ¹¹ / ₁₆	55 ¹³ / ₁₆	11 ⁷ / ₁₆		
DU-RAD-3124	208, 240 or 275	7.76	93 ³ / ₄	84 ⁷ / ₈	62	11 ⁷ / ₁₆	
DU-RAD-3136		8.33	99 ³ / ₄	90 ⁷ / ₈	68	11 ⁷ / ₁₆	
DU-RAD-3148		8.90	105 ³ / ₄	97	74 ¹ / ₈	11 ⁷ / ₁₆	
DU-RAD-3156		9.30	109 ⁵ / ₁₆	101 ³ / ₁₆	78 ³ / ₈	11 ⁷ / ₁₆	
DU-RAD-3164		9.65	114 ¹ / ₁₆	105 ⁵ / ₁₆	82 ⁵ / ₈	11 ⁷ / ₁₆	
DU-RAD-3172		10.03	118 ¹ / ₄	109 ³ / ₈	86 ¹ / ₂	11 ⁷ / ₁₆	
DU-RAD-440		5.20	66 ³ / ₄	57 ¹ / ₈	19 ¹ / ₄	19 ⁵ / ₁₆	
DU-RAD-448		5.57	70 ³ / ₄	61 ¹ / ₈	23 ¹ / ₄	19 ⁵ / ₁₆	
DU-RAD-540		208, 240 or 275	6.60	81 ³ / ₈	72 ³ / ₄	19 ¹ / ₄	26 ³ / ₄
DU-RAD-548			6.97	85 ³ / ₈	76 ³ / ₄	23 ¹ / ₄	26 ³ / ₄
DU-RAD-558		208, 240, 275 or 480	7.44	90 ³ / ₈	81 ⁷ / ₈	28 ³ / ₈	26 ³ / ₄
DU-RAD-566			7.82	94 ³ / ₈	85 ⁷ / ₈	32 ³ / ₈	26 ³ / ₄
DU-RAD-574	8.19		98 ³ / ₈	90	36 ³ / ₈	26 ³ / ₄	
DU-RAD-582	8.57		102 ⁵ / ₁₆	94 ¹ / ₈	40 ³ / ₈	26 ³ / ₄	
DU-RAD-590	8.95		107 ¹ / ₈	98 ¹ / ₈	44 ¹ / ₁₆	26 ³ / ₄	
DU-RAD-5102	9.52		113 ¹ / ₈	104 ³ / ₁₆	50 ¹ / ₁₆	26 ³ / ₄	
DU-RAD-5112	9.99		118 ³ / ₁₆	109 ⁵ / ₁₆	55 ¹³ / ₁₆	26 ³ / ₄	
DU-RAD-5124	10.56		124 ³ / ₈	115 ¹ / ₂	62	26 ³ / ₄	
DU-RAD-5136	11.13		130 ³ / ₈	121 ¹ / ₂	68	26 ³ / ₄	
DU-RAD-5148	11.70		136 ¹ / ₂	127 ³ / ₈	74 ¹ / ₈	26 ³ / ₄	
DU-RAD-5156	12.10		140 ³ / ₈	131 ¹ / ₁₆	78 ³ / ₈	26 ³ / ₄	
DU-RAD-5164	12.45		144 ¹¹ / ₁₆	135 ¹³ / ₁₆	82 ⁵ / ₈	26 ³ / ₄	
DU-RAD-5172	12.83	148 ³ / ₈	140	86 ¹ / ₂	26 ³ / ₄		
DU-RAD-640	208, 240 or 275	7.60	93 ³ / ₄	84 ⁷ / ₈	19 ¹ / ₄	32 ¹³ / ₁₆	
DU-RAD-648		7.97	97 ³ / ₄	88 ⁷ / ₈	23 ¹ / ₄	32 ¹³ / ₁₆	
DU-RAD-658	208, 240, 275 or 480	8.44	102 ⁷ / ₈	94	28 ³ / ₈	32 ¹³ / ₁₆	
DU-RAD-666		8.82	106 ⁷ / ₈	98	32 ³ / ₈	32 ¹³ / ₁₆	
DU-RAD-674		9.19	111	102 ⁷ / ₈	36 ³ / ₈	32 ¹³ / ₁₆	
DU-RAD-682		9.57	115 ¹ / ₈	106 ³ / ₈	40 ³ / ₈	32 ¹³ / ₁₆	
DU-RAD-690		9.95	119 ³ / ₈	110 ³ / ₈	44 ¹ / ₁₆	32 ¹³ / ₁₆	
DU-RAD-6102		10.52	125 ³ / ₈	116 ³ / ₈	50 ¹¹ / ₁₆	32 ¹³ / ₁₆	
DU-RAD-6112		10.99	130 ³ / ₈	121 ⁷ / ₁₆	55 ¹³ / ₁₆	32 ¹³ / ₁₆	
DU-RAD-6124		11.56	136 ¹ / ₂	127 ³ / ₈	62	32 ¹³ / ₁₆	
DU-RAD-6136		12.13	142 ¹ / ₂	133 ³ / ₈	68	32 ¹³ / ₁₆	
DU-RAD-6148		12.70	148 ¹ / ₂	139 ³ / ₈	74 ¹ / ₈	32 ¹³ / ₁₆	
DU-RAD-6156		13.10	152 ¹¹ / ₁₆	143 ³ / ₁₆	78 ³ / ₈	32 ¹³ / ₁₆	
DU-RAD-6164		13.45	156 ¹³ / ₁₆	147 ¹⁵ / ₁₆	82 ⁵ / ₈	32 ¹³ / ₁₆	
DU-RAD-6172		13.83	161	152 ¹ / ₈	86 ¹ / ₂	32 ¹³ / ₁₆	
DU-RAD-740		208, 240 or 275	8.80	106	97 ¹ / ₈	19 ¹ / ₄	38 ¹⁵ / ₁₆
DU-RAD-748	9.17		110	101 ¹ / ₈	23 ¹ / ₄	38 ¹⁵ / ₁₆	
DU-RAD-758	208, 240, 275 or 480	9.64	115 ¹ / ₈	106 ¹ / ₄	28 ³ / ₈	38 ¹⁵ / ₁₆	
DU-RAD-766		10.02	119 ¹ / ₈	110 ¹ / ₄	32 ³ / ₈	38 ¹⁵ / ₁₆	
DU-RAD-774		10.39	123 ¹ / ₄	114 ³ / ₈	36 ³ / ₂	38 ¹⁵ / ₁₆	
DU-RAD-782		10.77	127 ³ / ₈	118 ¹ / ₈	40 ³ / ₈	38 ¹⁵ / ₁₆	
DU-RAD-790		11.15	131 ¹ / ₈	122 ³ / ₁₆	44 ¹ / ₁₆	38 ¹⁵ / ₁₆	
DU-RAD-7102		11.72	137 ⁷ / ₁₆	128 ³ / ₁₆	50 ¹ / ₁₆	38 ¹⁵ / ₁₆	
DU-RAD-7112		12.19	142 ⁵ / ₁₆	133 ¹ / ₁₆	55 ¹³ / ₁₆	38 ¹⁵ / ₁₆	
DU-RAD-7124		12.76	148 ³ / ₈	139 ³ / ₈	62	38 ¹⁵ / ₁₆	
DU-RAD-7136		13.33	154 ³ / ₈	145 ³ / ₈	68	38 ¹⁵ / ₁₆	
DU-RAD-7148		13.90	160 ¹ / ₄	152	74 ¹ / ₈	38 ¹⁵ / ₁₆	
DU-RAD-7156		14.30	164 ⁵ / ₁₆	156 ¹ / ₁₆	78 ³ / ₈	38 ¹⁵ / ₁₆	
DU-RAD-7164		14.65	169 ¹ / ₈	160 ³ / ₈	82 ⁵ / ₈	38 ¹⁵ / ₁₆	
DU-RAD-7172		15.03	173 ¹ / ₄	164 ³ / ₈	86 ¹ / ₂	38 ¹⁵ / ₁₆	

INSTALLATION

⚠ WARNING

The system designer is responsible for the safety of this equipment and should install adequate back-up controls and safety devices with their electric heating equipment. Where the consequences of failure could result in personal injury or property damage, back-up controls are essential.

Before Installing

1. Open carton and remove heater at the place of installation. Mounting clamps are in parts bag in carton.
2. Check nameplate volt and watt rating against your power supply voltage and heating requirements of your installation. This nameplate of the complete assembly is located on the back of the heater housing. **Note:** Single element heaters have one nameplate. Three element heaters have four nameplates (one for each element and one for the complete assembly).

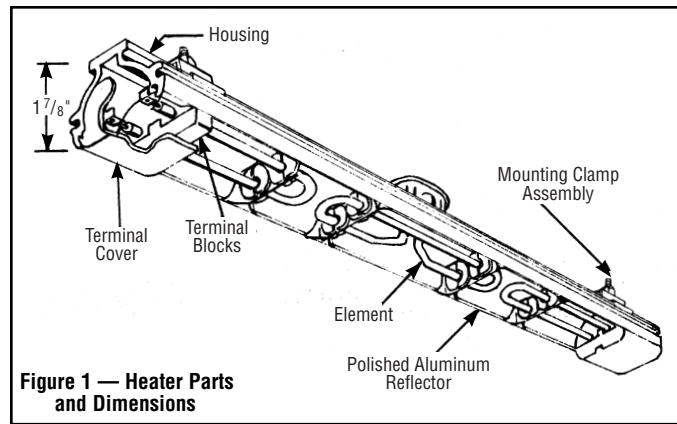

MOUNTING

⚠ WARNING

FIRE HAZARD. Since heaters are capable of developing high temperatures, extreme care should be taken to maintain adequate spacing between heater and combustible materials. Failure to comply can result in personal injury or property damage.

Mounting

1. **Clamps** — Heaters are mounted by means of the mounting clamp and 3/8" bolt assembly which is used as shown in Fig. 2. Clamp assembly may be attached to heater by sliding over end or by snapping over top of extruded frame section at any point along its length. (see Fig. 3) For proper heater support, the maximum distance between clamps must not exceed 48". On extra-long heaters, more than two clamps are furnished.

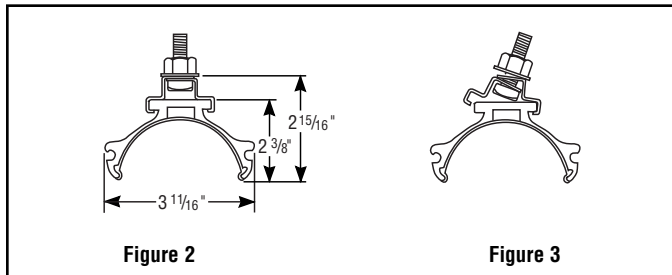

2. **Mounting Holes** — When heaters are mounted adjacent to each other in the same plane, the minimum distance will depend on whether the wiring to the center element enters the terminal box through the connector furnished or through a right angle connector (not furnished).
3. **Framing** — Where an extensive installation is being made, the use of continuous slot metal framing manufactured by several concerns will be of assistance in saving time and money. The framing is reusable.

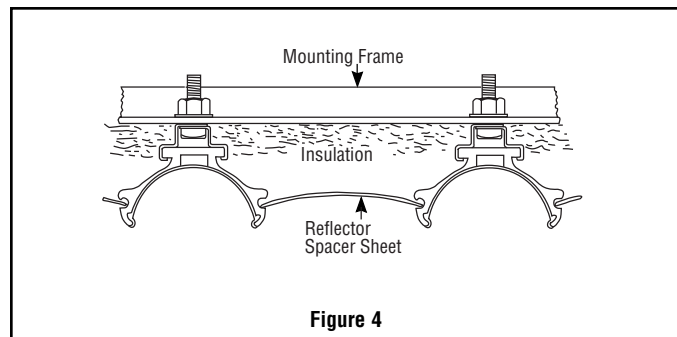

4. **Reflector Spacer Sheets** — Where heaters are not mounted side by side (see Fig. 4), reflector spacer sheets can be used between heaters. These reflector spacer sheets and companion reflectors consisting of an extruded aluminum housing with reflector sheet and mounting clamps are available. Check factory or local Chromalox Sales and Application Engineers.
5. **Insulation** — Where unusually high work temperatures are encountered, it may be desirable to insulate with high temperature insulation. **Note:** An air space should be left between backs of heaters and insulation. (see Figure 4)
6. **Ventilation** — Where solvents, water, etc. are being evaporated from work in process, it is necessary to provide substantial quantities of ventilation air to carry away the resulting vapors.

IMPORTANT -

In the case of solvents of an explosive nature, ventilation air must be in sufficient volume to dilute the solvent vapor so that explosive mixtures cannot occur. In order to comply with the standards of safety required by the insurance companies, ventilation protection and other facilities must be in accordance with NFPA Bulletin No. 86, entitled "Standard for Ovens and Furnaces". This Bulletin may be obtained from the Association at 470 Atlantic Avenue, Boston Mass., 02110

⚠ WARNING

FIRE/EXPLOSION HAZARD. This heater is not intended for use in hazardous atmospheres where flammable vapors, gases, liquids or other combustible atmospheres are present as defined in the National Electrical Code. Failure to comply can result in personal injury or property damage.

WIRING

⚠ WARNING

ELECTRIC SHOCK HAZARD. Disconnect all power before installing or servicing heater. Failure to do so could result in personal injury or property damage. Heater must be installed by a qualified person in accordance with the National Electrical Code, NFPA 70.

⚠ WARNING

ELECTRIC SHOCK HAZARD. Any installation involving electric heaters must be performed by a qualified person and must be effectively grounded in accordance with the National Electrical Code to eliminate shock hazard.

1. The power supply voltage should be the voltage as specified on the heater nameplate located on the heater housing.
2. Wiring should be run in flexible or rigid metal conduit and must be installed in accordance with the requirements of the National Electrical Code and such other local requirements as may be applicable. **Note:** High temperatures will oxidize copper. Do not use copper wire in connecting this heater. Nickel-plated copper wire, insulated in accordance with requirements for temperature and voltage is recommended.
3. A sufficient length of this wire (not less than 12") should be used to extend from each heater terminal into a connection box location where the temperature does not exceed 300°F.

4. ELECTRICAL CONNECTIONS —

A. End Elements

Electrical connection to the heater end elements is made through the 7/8" dia. opening in the end of the terminal cover of the element assembly. A 1/2" flexible conduit connector is provided with each element assembly for this purpose.

B. Center Elements

Electrical connection to the heater center element is made through the 7/8" dia. opening in the 4" octagon conduit box for the element assembly. A 1/2" flexible conduit connector is provided with each element assembly for this purpose.

5. ACCESS TO TERMINALS

A. End Elements

Access to the end element terminals is obtained by removing the mounting bolt, nut and spacer (see Figure 9, items 9, 16 and 18) and sliding the terminal end of the element assembly out of the housing.

B. Center Elements

Access to the center mounted element terminals is obtained by removing the terminal box cover.

6. END ELEMENT TERMINAL ASSEMBLY

Assemble end terminal, screw and wire as shown in Figure 5. Hold terminal with pliers and tighten the terminal screw securely with a screwdriver.

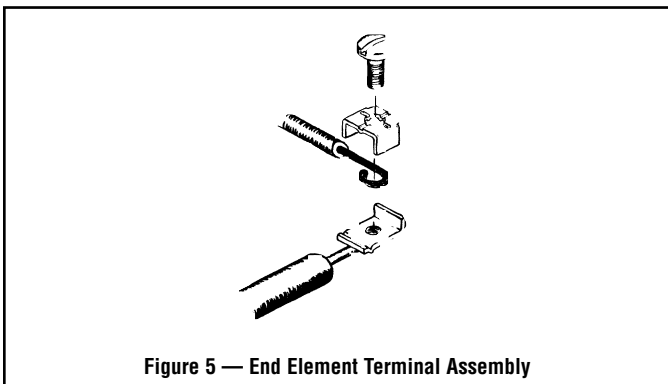

7. CENTER ELEMENT TERMINAL ASSEMBLY

Assemble center terminal, washers, nut and wire as shown in Figure 6. Hold terminal with pliers and tighten the terminal nut securely with a wrench.

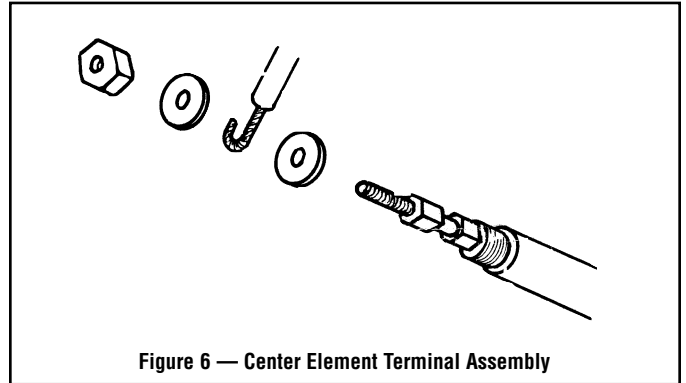

CAUTION: Terminal clip is spot-welded to element terminal pin and over-tightening terminal screw may break the weld or shear off terminal pin. However, either the screw or nut should be sufficiently tightened to eliminate arcing.

8. **SERIES CONNECTION** of Radiant Heaters of equal volt and watt rating is permitted in all line voltages up to 600 volts. In making such series connections it is necessary to observe the "right" (series-parallel) connection rather than the "wrong" (parallel-series) connection both shown in Figure 7. If heaters are connected according to the "wrong" illustration, failure of any heater will cause progressive failure of other heaters still operating.

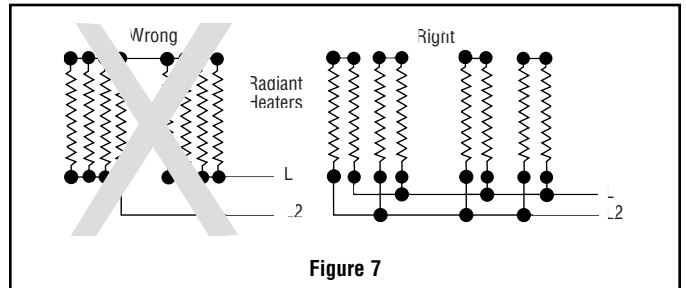

9. **DELTA CONNECTIONS** — When heaters occur in multiples of three, they may be connected to, and balanced across, three-phase lines. The most commonly used connection is the delta connection illustrated in Figure 8.

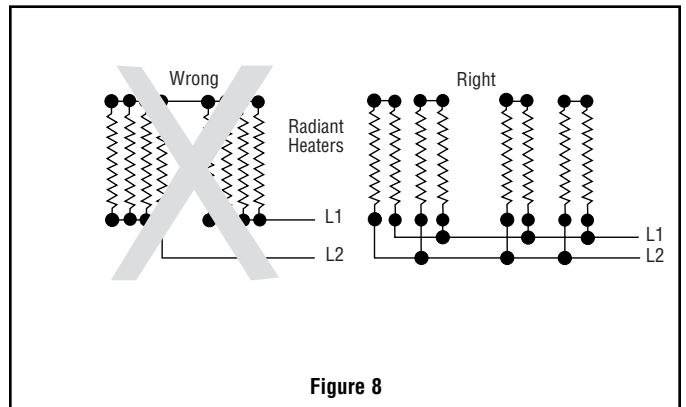

Three phase Delta connections to minimize inductive effect in conduits are made per this diagram. The rule: run all 3 three-phase conductors in the same conduit as far as possible. For single-phase, run only two conductors and follow the same rule.

OPERATION

CAUTION: For your own safety —

Before energizing this heater:

1. **Be sure** all electrical connections are tightly made.
2. **Be sure** that all conductors are properly insulated.
3. **Be sure** that terminal box cover has been properly replaced, and that secondary insulation bushings have not been omitted.

Controlling Radiant Intensity —

Standard Radiant Heaters are built to operate at 40 watts per sq. inch on the element sheath. When it is desired to reduce radiant intensity, one or more of the following methods may be used.

1. **INPUT CONTROLLERS.** These motor-driven cycling devices can be used to vary heater output capacity from 4 to 100%. They are usually connected in holding coil circuit of magnetic contactors. See Chromalox Radiant Heater Manual for further information regarding Input Controllers and Contactors.

2. **SOLID STATE THYRISTOR POWER CONTROLLERS.**

For best non-contact control of radiant heat, a Series #6 Chromalox Thyristor Power Controller with manual potentiometer setting is recommended. Truly proportional output of from 0 – 100% can be easily dialed-in to suit the particular product or process requirements. The Series #6 panels are pre-engineered, pre-packaged assemblies in an enclosure with circuit disconnect provided and ready for installation.

Maximum Ambient Temperatures —

Chromalox Radiant Heaters are not recommended for applications in ambient temperatures exceeding 450°F. Higher ambient temperatures mean shorter heater life.

Maximum work temperature in a given time depends on several factors: Reflectivity of work, specific heat of work, mass of work, kW input and losses from oven, and time of exposure. As work temperature increases, the work loses heat by radiation and by convection to the surrounding ambient. Although it is a general principle of a Radiant Heater application that work temperature conventionally exceeds ambient temperature, in cases where extremely high work temperatures are desired, it is necessary to

enclose the heaters in order to increase the ambient. If evaporation of a liquid is desired as a result of increasing work temperature, it is necessary to provide ventilation air in order to carry away the evaporated liquid. Under carefully engineered circumstances, a maximum work temperature of 600°F may be attained.

Low Megohm Condition — The refractory material used in electric heaters may absorb moisture during transit, storage or when subject to humid environments that will reduce the cold insulation resistance (low megohm). Low megohm may result in a high leakage current to ground and nuisance trips of ground fault protection equipment. Normally, the megohm value increases after heat-up. Typical insulation values are 5 megohm or greater on complete assemblies or 20 megohm on individual unsealed elements. It is recommended that heaters with 1 megohm or less be dried out before applying full power. If dried properly, low megohm will not effect heater life or efficiency.

To correct a low megohm condition, remove terminal enclosure cover, gaskets, and terminal hardware. Bake heaters in an oven at 300 to 350°F for several hours or preferably overnight.

An alternate procedure is to cycle the heater in 10 to 15 minute periods at low voltage until megohm values are normal. Sheath temperatures should not exceed 350°F.

Note: Low megohm on heating elements with epoxy or hermetic seals cannot be serviced in the field. Typical resistance values when sealed are 200 megohm or greater. Contact Chromalox service center at number listed.

⚠ WARNING

FIRE OR SHOCK HAZARD. Moisture accumulation in the element refractory material, element over-temperature or sheath corrosion can cause ground fault to the element sheath, generating arcing and molten metal. Install Ground Fault Protection to prevent property damage.

MAINTENANCE

⚠ WARNING

ELECTRIC SHOCK HAZARD. Disconnect all power before installing or servicing heater. Failure to do so could result in personal injury or property damage. Heater must be installed by a qualified person in accordance with the National Electrical Code, NFPA 70.

To Remove Heating Element —

1. End Elements

- A. Remove element assembly mounting nut and bolt (18) and (16) and element support clips (see Figure 9) and slide element assembly out of housing.
- B. Disconnect heating element from electrical leads at both ends.
- C. Remove screws from porcelain terminal blocks.
- D. Remove element support clips and secondary insulating bushings.
- E. Lift out element.

2. Center Elements

- A. Remove terminal box cover.
- B. Disconnect heating element from electrical leads and remove all hardware from terminals.
- C. Remove screws (24) from secondary insulator retaining bracket and remove bracket (22).

- D. Remove secondary insulation bushings (23).
- E. Unclip element support clips (12) from housing. (See Fig. 10)
- F. Lift out element.
- G. Remove element support clips (12), bushing retaining clip (14) and insulating bushings (13) from element.

To Install Element —

Observe instructions for removing element and proceed in reverse order. Be sure to replace secondary insulating bushings.

Care of Reflectors —

Reflectors should be cleaned periodically. A mild soap and water solution or fine cleaning powder is best although more drastic means may be required if reflectors are badly soiled by chemical or other deposits. The reflector is aluminum. DO NOT use alkali cleaners since alkalies will dull reflector. Mild non-alkaline cleaners, such as used for scouring kitchen sinks, may be used. Reflectors are replaceable and may be purchased from Chromalox.

RENEWAL PARTS IDENTIFICATION

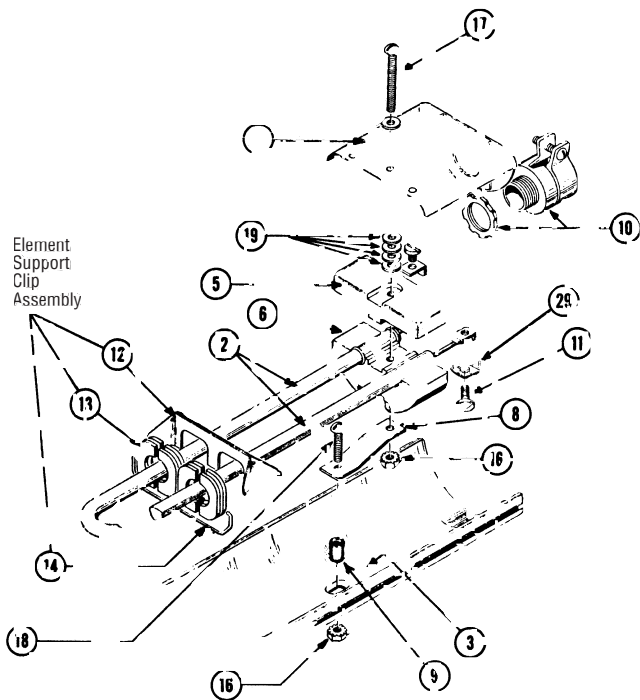

Figure 9 — End Element

Note: To order specify quantity, Model Number, Volts, kW.

PARTS COMMON TO ALL DU-RAD HEATERS		
④	Reflector (center)	234-114406-001
②①	#10-32 Nut (4)	200-075520-067
②②	Cup Washer	328-075560-002
②③	Bushing retaining bracket	027-018140-001
②④	Insulating bushing (2)	162-017459-001
②⑤	#10-32 x 3/8 Ig. Screw (2)	248-075414-093
②⑥	#10 Flat Washer (2)	328-075528-036

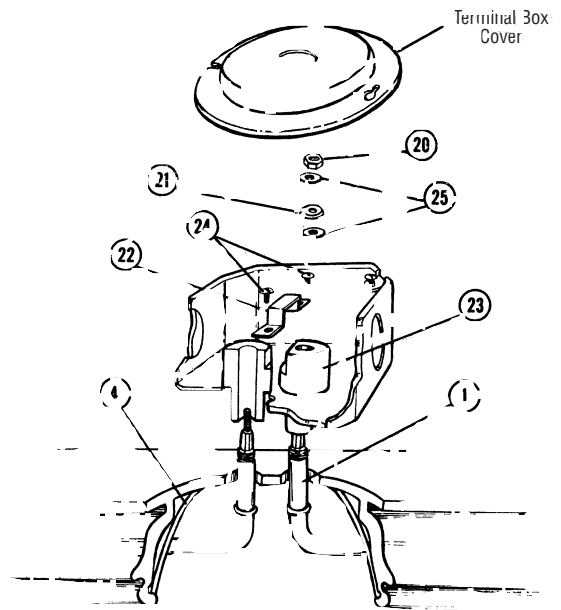

Figure 10 — Center Element

PARTS COMMON TO ALL DU-RAD HEATERS		
⑤	Terminal Block	303-014316-001
⑥	Terminal Block	303-014317-001
⑦	Terminal Cover	080-016868-001
⑧	Bracket	027-016372-001
⑨	Spacer	032-075525-012
⑩	1/2" Flexible Conduit Connector and Locknut	119-075454-005 & 200-075482-002
⑪	Terminal Screw	248-046044-002 (4)
⑫	Element Support Clip	059-014304-002
⑬	Insulating Bushing	032-013454-001
⑭	Bushing Retaining Clip	059-017175-001
⑮	Mounting Clamp Parts Bag - For mounting heaters with overall length less than 74 1/2", use Parts Bag 162-013071-001. For heaters with 74 1/2" or larger overall length, use two Parts Bags 168-013071-001.	
MISCELLANEOUS HARDWARE		
⑯	#8-32 Nut	200-075520-064
⑰	#8-32 x 1 3/4" Screws	248-075512-194
⑱	#8-32 x 1" Screws	248-075512-185
⑲	#8 Washer	328-075528-020
⑳	Saddle Clamp	238-026539-001 (4)

WIRING

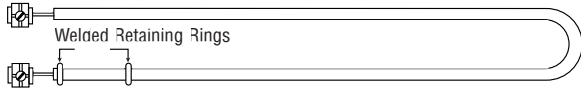

Figure 11 — Type UTU Single Hairpin

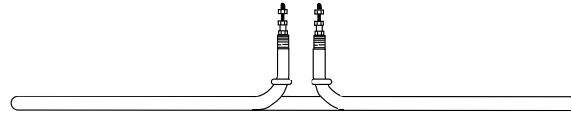

Figure 12 — Type UTU Double Hairpin

Table B –

Type UTU – Single Hairpin Elements		
Volts	kW	Model
120 or 240 208 or 275	0.8 0.8	UTU-2 UTU-2V
120 or 240 208 or 275	1.1 1.1	UTU-3 UTU-3V
208 or 275 240 or 480	1.8 1.8	UTU-4V UTU-4
208 or 275 240 or 480	2.5 2.5	UTU-5V UTU-5
208 or 275 240 or 480	3.0 3.0	UTU-6V UTU-6
208 or 275 240 or 480	3.6 3.6	UTU-7V UTU-7

Table C –

Type UTU – Double Hairpin Elements		
Volts	kW	Model
120 or 240 208 or 275	1.6 1.6	UTU-40 UTU-40V
120 or 240 208 or 275	1.97 1.97	UTU-48 UTU-48V
120, 240 or 480 208 or 275	2.44 2.44	UTU-58 UTU-58V
120, 240 or 480 208 or 275	2.82 2.82	UTU-66 UTU-66V
120, 240 or 480 208 or 275	3.19 3.19	UTU-74 UTU-74V
208 or 275 240 or 480	3.57 3.57	UTU-82V UTU-82
208 or 275 240 or 480	3.95 3.95	UTU-90V UTU-90
208 or 275 240 or 480	4.52 4.52	UTU-102V UTU-102
208 or 275 240 or 480	4.99 4.99	UTU-112V UTU-112
208 or 275 240 or 480	5.56 5.56	UTU-124V UTU-124
208 or 275 240 or 480	6.13 6.13	UTU-136V UTU-136
208 or 275 240 or 480	6.7 6.7	UTU-148V UTU-148
208 or 275 240 or 480	7.1 7.1	UTU-156V UTU-156
208 or 275 240 or 480	7.45 7.45	UTU-164V UTU-164
208 or 275 240 or 480	7.83 7.83	UTU-172V UTU-172

Model	kW	① Basic Element Model*	③ Reflector	⑳ Aluminum Housing
DU-RAD-040	1.60	UTU-40	234-013411-067 (2)	152-114962-001
DU-RAD-048	1.97	UTU-48	234-013411-068 (2)	152-114962-002
DU-RAD-058	2.44	UTU-58	234-013411-069 (2)	152-114962-003
DU-RAD-066	2.82	UTU-66	234-013411-070 (2)	152-114962-004
DU-RAD-074	3.19	UTU-74	234-013411-071 (2)	152-114962-005
DU-RAD-082	3.57	UTU-82	234-013411-072 (2)	152-114962-006
DU-RAD-090	3.95	UTU-90	234-013411-073 (2)	152-114962-007
DU-RAD-0102	4.52	UTU-102	234-013411-074 (2)	152-114962-008
DU-RAD-0112	4.99	UTU-112	234-013411-075 (2)	152-114962-009
DU-RAD-0124	5.56	UTU-124	234-013411-076 (2)	152-114962-010
DU-RAD-0136	6.13	UTU-136	234-013411-077 (2)	152-114962-011
DU-RAD-0148	6.70	UTU-148	234-013411-078 (2)	152-114962-012
DU-RAD-0156	7.10	UTU-156	234-013411-079 (2)	152-114962-013
DU-RAD-0164	7.45	UTU-164	234-013411-080 (2)	152-114962-014
DU-RAD-0172	7.83	UTU-172	234-013411-081 (2)	152-114962-015

*This is basic Model Number. See Table B or Table C for variation in element model number depending upon voltage.

Model	Total kW	① Center Only Element Model*	② End Only Element Model*	③ Reflector	⑳ Aluminum Housing
DU-RAD-240	3.20	UTU-40	UTU-2	234-016383-013 (2)	152-017463-001
DU-RAD-248	3.57	UTU-48	UTU-2	234-016383-014 (2)	152-017463-002
DU-RAD-258	4.04	UTU-58	UTU-2	234-016383-016 (2)	152-017463-004
DU-RAD-266	4.42	UTU-66	UTU-2	234-016383-018 (2)	152-017463-006
DU-RAD-274	4.79	UTU-74	UTU-2	234-016383-020 (2)	152-017463-008
DU-RAD-282	5.17	UTU-82	UTU-2	234-016383-022 (2)	152-017463-010
DU-RAD-290	5.55	UTU-90	UTU-2	234-016383-025 (2)	152-017463-013
DU-RAD-2102	6.12	UTU-102	UTU-2	234-016383-029 (2)	152-017463-017
DU-RAD-2112	6.59	UTU-112	UTU-2	234-016383-032 (2)	152-017463-019
DU-RAD-2124	7.16	UTU-124	UTU-2	234-016383-036 (2)	152-017463-023
DU-RAD-2136	7.73	UTU-136	UTU-2	234-016383-042 (2)	152-017463-027
DU-RAD-2148	8.30	UTU-148	UTU-2	234-016383-047 (2)	152-017463-032
DU-RAD-2156	8.70	UTU-156	UTU-2	234-016383-041 (2)	152-017463-035
DU-RAD-2164	9.05	UTU-164	UTU-2	234-016383-056 (2)	152-017463-038
DU-RAD-2172	9.43	UTU-172	UTU-2	234-016383-061 (2)	152-017463-042

*This is basic Model Number. See Table B or Table C for variation in element catalog number depending upon voltage.

Model	Total kW	① Center Only Element Model*	② End Only Element Model*	③ Reflector	⑳ Aluminum Housing
DU-RAD-340	3.80	UTU-40	UTU-3	234-016383-015 (2)	152-017463-003
DU-RAD-348	4.17	UTU-48	UTU-3	234-016383-017 (2)	152-017463-005
DU-RAD-358	4.64	UTU-58	UTU-3	234-016383-019 (2)	152-017463-007
DU-RAD-366	5.02	UTU-66	UTU-3	234-016383-021 (2)	152-017463-009
DU-RAD-374	5.39	UTU-74	UTU-3	234-016383-024 (2)	152-017463-012
DU-RAD-382	5.77	UTU-82	UTU-3	234-016383-027 (2)	152-017463-015
DU-RAD-390	6.15	UTU-90	UTU-3	234-016383-030 (2)	152-017463-017
DU-RAD-3102	6.72	UTU-102	UTU-3	234-016383-005 (2)	152-017463-020
DU-RAD-3112	7.19	UTU-112	UTU-3	234-016383-036 (2)	152-017463-023
DU-RAD-3124	7.76	UTU-124	UTU-3	234-016383-042 (2)	152-017463-027
DU-RAD-3136	8.33	UTU-136	UTU-3	234-016383-048 (2)	152-017463-032
DU-RAD-3148	8.90	UTU-148	UTU-3	234-016383-052 (2)	152-017463-036
DU-RAD-3156	9.30	UTU-156	UTU-3	234-016383-058 (2)	152-017463-040
DU-RAD-3164	9.65	UTU-164	UTU-3	234-016383-063 (2)	152-017463-044
DU-RAD-3172	10.03	UTU-172	UTU-3	234-016383-067 (2)	152-017463-047

TESTING AND OPERATION

Model	Total kW	① Center Only Element Model*	② End Only Element Model*	③ Reflector	⑳ Aluminum Housing
Three Element Models					
DU-RAD-440	5.20	UTU-40	UTU-4	234-016383-023 (2)	152-017463-011
DU-RAD-448	5.57	UTU-48	UTU-4	234-016383-026 (2)	152-017463-014
DU-RAD-458	6.04	UTU-58	UTU-4	234-016383-028 (2)	152-017463-016
DU-RAD-466	6.42	UTU-66	UTU-4	234-016383-031 (2)	152-017463-018
DU-RAD-474	6.79	UTU-74	UTU-4	234-016383-034 (2)	152-017463-021
DU-RAD-482	7.17	UTU-82	UTU-4	234-016383-038 (2)	152-017463-024
DU-RAD-490	7.55	UTU-90	UTU-4	234-016383-040 (2)	152-017463-026
DU-RAD-4102	8.12	UTU-102	UTU-4	234-016383-045 (2)	152-017463-030
DU-RAD-4112	8.59	UTU-112	UTU-4	234-016383-051 (2)	152-017463-034
DU-RAD-4124	9.16	UTU-124	UTU-4	234-016383-057 (2)	152-017463-039
DU-RAD-4136	9.73	UTU-136	UTU-4	234-016383-066 (2)	152-017463-046
DU-RAD-4148	10.30	UTU-148	UTU-4	234-016383-071 (2)	152-017463-049
DU-RAD-4156	10.70	UTU-156	UTU-4	234-016383-075 (2)	152-017463-052
DU-RAD-4164	11.05	UTU-164	UTU-4	234-016383-077 (2)	152-017463-054
DU-RAD-4172	11.43	UTU-172	UTU-4	234-016383-080 (2)	152-017463-057
DU-RAD-540	6.60	UTU-40	UTU-5	234-016383-033 (2)	152-017463-019
DU-RAD-548	6.97	UTU-48	UTU-5	234-016383-035 (2)	152-017463-022
DU-RAD-558	7.44	UTU-58	UTU-5	234-016383-039 (2)	152-017463-025
DU-RAD-566	7.82	UTU-66	UTU-5	234-016383-043 (2)	152-017463-028
DU-RAD-574	8.19	UTU-74	UTU-5	234-016383-046 (2)	152-017463-031
DU-RAD-582	8.57	UTU-82	UTU-5	234-016383-050 (2)	152-017463-033
DU-RAD-590	8.95	UTU-90	UTU-5	234-016383-055 (2)	152-017463-037
DU-RAD-5102	9.52	UTU-102	UTU-5	234-016383-062 (2)	152-017463-043
DU-RAD-5112	9.99	UTU-112	UTU-5	234-016383-067 (2)	152-017463-047
DU-RAD-5124	10.56	UTU-124	UTU-5	234-016383-073 (2)	152-017463-050
DU-RAD-5136	11.13	UTU-136	UTU-5	234-016383-078 (2)	152-017463-055
DU-RAD-5148	11.70	UTU-148	UTU-5	234-016383-082 (2)	152-017463-058
DU-RAD-5156	12.10	UTU-156	UTU-5	234-016383-084 (2)	152-017463-060
DU-RAD-5164	12.45	UTU-164	UTU-5	234-016383-087 (2)	152-017463-062
DU-RAD-5172	12.83	UTU-172	UTU-5	234-016383-089 (2)	152-017463-063

Model	Total kW	① Center Only Element Model*	② End Only Element Model*	③ Reflector	⑳ Aluminum Housing
Three Element Models					
DU-RAD-640	7.60	UTU-40	UTU-6	234-016383-042 (2)	152-017463-027
DU-RAD-648	7.97	UTU-48	UTU-6	234-016383-044 (2)	152-017463-029
DU-RAD-658	8.44	UTU-58	UTU-6	234-016383-049 (2)	152-017463-033
DU-RAD-666	8.82	UTU-66	UTU-6	234-016383-054 (2)	152-017463-037
DU-RAD-674	9.19	UTU-74	UTU-6	234-016383-060 (2)	152-017463-041
DU-RAD-682	9.57	UTU-82	UTU-6	234-016383-064 (2)	152-017463-072
DU-RAD-690	9.95	UTU-90	UTU-6	234-016383-070 (2)	152-017463-073
DU-RAD-6102	10.52	UTU-102	UTU-6	234-016383-074 (2)	152-017463-051
DU-RAD-6112	10.99	UTU-112	UTU-6	234-016383-078 (2)	152-017463-055
DU-RAD-6124	11.56	UTU-124	UTU-6	234-016383-081 (2)	152-017463-058
DU-RAD-6136	12.13	UTU-136	UTU-6	234-016383-085 (2)	152-017463-061
DU-RAD-6148	12.70	UTU-148	UTU-6	234-016383-088 (2)	152-017463-063
DU-RAD-6156	13.10	UTU-156	UTU-6	234-016383-091 (2)	152-017463-064
DU-RAD-6164	13.45	UTU-164	UTU-6	234-016383-093 (2)	152-017463-066
DU-RAD-6172	13.83	UTU-172	UTU-6	234-016383-095 (2)	152-017463-067
DU-RAD-740	8.80	UTU-40	UTU-7	234-016383-053 (2)	152-017463-036
DU-RAD-748	9.17	UTU-48	UTU-7	234-016383-059 (2)	152-017463-040
DU-RAD-758	9.64	UTU-58	UTU-7	234-016383-065 (2)	152-017463-045
DU-RAD-766	10.02	UTU-66	UTU-7	234-016383-069 (2)	152-017463-048
DU-RAD-774	10.39	UTU-74	UTU-7	234-016383-072 (2)	152-017463-071
DU-RAD-782	10.77	UTU-82	UTU-7	234-016383-076 (2)	152-017463-053
DU-RAD-790	11.15	UTU-90	UTU-7	234-016383-079 (2)	152-017463-056
DU-RAD-7102	11.72	UTU-102	UTU-7	234-016383-083 (2)	152-017463-059
DU-RAD-7112	12.19	UTU-112	UTU-7	234-016383-085 (2)	152-017463-061
DU-RAD-7124	12.76	UTU-124	UTU-7	234-016383-089 (2)	152-017463-063
DU-RAD-7136	13.33	UTU-136	UTU-7	234-016383-092 (2)	152-017463-065
DU-RAD-7148	13.90	UTU-148	UTU-7	234-016383-094 (2)	152-017463-067
DU-RAD-7156	14.30	UTU-156	UTU-7	234-016383-096 (2)	152-017463-068
DU-RAD-7164	14.65	UTU-164	UTU-7	234-016383-097 (2)	152-017463-069
DU-RAD-7172	15.03	UTU-172	UTU-7	234-016383-098 (2)	152-017463-070

*This is basic Model Number. See Table B and C for variation in model number depending upon voltage.

Note: Part Numbers suffixed by a number in () indicates the number of parts of same part number used or supplied if more than one.

Limited Warranty:

Please refer to the Chromalox limited warranty applicable to this product at <http://www.chromalox.com/customer-service/policies/termsofsale.aspx>.

Chromalox[®]
PRECISION HEAT AND CONTROL

2150 N. RULON WHITE BLVD., OGDEN, UT 84404
Phone: 1-800-368-2493 www.chromalox.com