

HP Scanjet N8400 series

User Guide



Copyright and license

© 2007 Copyright Hewlett-Packard
Development Company, L.P.

Reproduction, adaptation or translation
without prior written permission is
prohibited, except as allowed under the
copyright laws.

The information contained herein is
subject to change without notice.

The only warranties for HP products
and services are set forth in the express
warranty statements accompanying
such products and services. Nothing
herein should be construed as
constituting an additional warranty. HP
shall not be liable for technical or
editorial errors or omissions contained
herein.

Trademark credits

ENERGY STAR is a U.S. registered
service mark of the United States
Environmental Protection Agency.

Microsoft and Windows are registered
trademarks of Microsoft Corporation.

Contents

1 Scanner overview	
What you can do with the scanner.....	3
Scanner hardware.....	4
Scanner front panel buttons.....	4
Power Save button.....	4
Quick start buttons.....	4
Copy buttons.....	5
Scan Document To buttons.....	5
Tools button.....	6
Cancel button.....	6
Scanner lamp setting.....	6
Scanner software.....	6
HP Smart Document Scan Software.....	6
HP Document Copy Utility.....	7
HP Scanner Tools Utility.....	7
Where to get additional information.....	8
Accessibility.....	9
LCD Reader.....	9
Control of the scanner buttons.....	9
2 Scan and Copy	
Basic scanning steps.....	10
Basic copying steps.....	10
Load originals.....	11
Place an original on the scanner glass.....	11
Load paper into the document feeder.....	11
Scan from the scanner front panel buttons.....	12
Scan from HP Smart Document Scan Software.....	12
Scan from other software programs.....	13
Scan with one button press.....	13
3 Set up scan profiles	
Set up an HP Smart Document Scan Software profile.....	14
Assign profiles to quick start buttons.....	15
Choose profiles for display on the scanner front panel.....	15
Import and export profiles.....	16
4 Care and maintenance	
HP Scanner Tools Utility Maintenance tab.....	17
Order maintenance and scanning supplies.....	17
Clean the scanner glass.....	17

Maintain the automatic document feeder (ADF).....	18
Clean the paper path.....	18
Clean the ADF window.....	19
Clean the feed roller.....	20
Replace the feed roller and separation pad.....	23
Remove the automatic document feeder from the scanner.....	23
5 Troubleshooting	
Scanner error messages.....	25
Scanner initialization or hardware problems.....	27
Scanner does not start.....	27
Scanner has stopped working correctly.....	28
Scanner operation problems.....	28
Scanner will not turn on.....	28
Scanner lamp stays on.....	29
Scanner does not scan right away.....	29
Scanner scans only one side of a double-sided page.....	29
Scanned image is fuzzy.....	29
Scanned pages are out of order at the scan destination.....	29
Scanner is scanning items very slowly.....	29
The image is completely black or completely white.....	29
Scanned images are not straight.....	30
Vertical white stripes appear on the printed page.....	30
Scanner glass is dirty.....	30
Scan files are too large.....	30
Scanner buttons are not working correctly.....	31
Buttons do not work.....	31
An unexpected program opens when a button is pressed.....	31
Wrong profile is used when a quick start button is pressed.....	31
Automatic document feeder (ADF) problems.....	32
Paper jamming, skewing, misfeeds, or multiple-page feeds.....	32
Paper does not feed from the ADF.....	32
The bottom of the scanned image is cut off.....	32
The scanned images have streaks or scratches.....	33
An item loaded in the ADF jams repeatedly.....	33
Clear jams from the ADF.....	33
Remove a paper jam within the ADF.....	36
Contact HP Support.....	36
6 Advanced technical features	
Long pages.....	37
Color dropout.....	37
Misfeed (Multipick) Detection.....	37
Index	39

1 Scanner overview

This user guide covers what you need to know about using the HP Scanjet N8400 series scanner.

- [What you can do with the scanner](#)
- [Scanner hardware](#)
- [Scanner software](#)
- [Where to get additional information](#)
- [Accessibility](#)

What you can do with the scanner

The following table summarizes the scanner features. Many of these features are available through the HP Smart Document Scan Software or other included scanning software. For more information, see the HP Smart Document Scan Software Help.

Feature	Description
Wide range of paper sizes	With the automatic document feeder (ADF), you can scan a stack of originals ranging from 148 mm x 148 mm (5.8 inches x 5.8 inches) to 215.9 mm x 355.6 mm (8.5 inches x 14 inches). You can also scan originals up to 215.9 mm x 863.6 mm (8.5 inches x 34 inches) through the feeder one page at a time. You can scan originals of any size up to 215.9 mm x 355.6 mm (8.5 inches x 14 inches) by placing them directly on the scanner glass.
Profiles	You can set up and use profiles that contain all settings necessary for scanning tasks such as: <ul style="list-style-type: none">• Document processing• Saving in different file formats (i.e. searchable or non-searchable PDF files) using automatic naming mechanisms• Sending to different destinations such as e-mail, Microsoft SharePoint, or other applications
Page management	You can view, edit, delete, insert, and reorder pages. You can also have the scanner automatically delete blank pages.
File management	You can scan all pages to a single file, scan each page to a separate file, or scan to separate files based on bar codes or blank pages in the original.
Optical Character Recognition (OCR)	With OCR software, you can scan originals as editable text that you can send to your favorite application.
Send Documents To	You can set up profiles to send the scanned documents to a variety of destinations such as a local folder, a network folder, e-mail, or a custom application.

Scanner hardware



1	Front panel
2	Automatic document feeder
3	Power button

Scanner front panel buttons

Use the buttons on the scanner front panel to start a scan, select a destination for a scan, and configure some scanner settings.

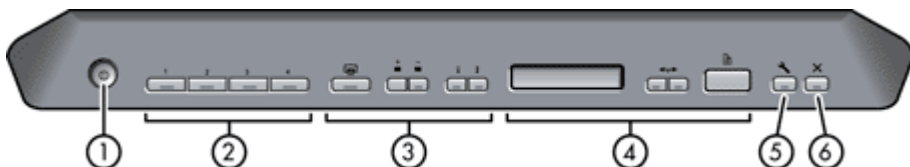

1	Power Save button
2	Quick start buttons
3	Copy buttons
4	Scan Document To buttons
5	Tools button
6	Cancel button

Power Save button



	<p>Press the Power Save button to turn off the lamp and put the scanner in power-save mode when you are not using the scanner. When you are ready to begin scanning again, just press one of the front panel scan buttons to turn the lamp back on and begin scanning immediately.</p>
---	--

Quick start buttons



The quick start buttons are labeled **1**, **2**, **3**, and **4**. You can use these buttons to scan with specific HP Smart Document Scan profiles, such as:

- Scan a document to a searchable PDF
- Send a scan directly to an e-mail program
- Scan a document for editable text

 **NOTE:** Use the HP Scanner Tools Utility, available from the **Tools** () button, to set up the quick start buttons.

NOTE: You can set a quick start button to start scanning with a specific HP Smart Document Scan Software profile or to start a different scanning program.

NOTE: If the HP Smart Document Scan Software is installed, each quick start button defaults to a standard profile. You can override these settings. For information on how to set up an HP Smart Document Scan Software profile, see the HP Smart Document Scan Software Help.



Copy buttons



To copy documents and images quickly, specify the number of copies to make, select black-and-white or color, and then click the **Copy** () button.

Scan Document To buttons



Use the arrow () buttons to scroll through the list of HP Smart Document Scan Software profiles that are displayed on the scanner front panel, and then press the **Scan Document To** () button to start scanning with the selected profile. For information on how to set up an HP Smart Document Scan Software profile, see the HP Smart Document Scan Software Help.

 **NOTE:** If the HP Smart Document Scan Software is not installed, these buttons have no effect.

Tools button

	Use the Tools button to open the HP Scanner Tools Utility where you can assign profiles to quick start buttons, choose which profiles are selectable from the scanner front panel, and view information about scanner settings, status, and maintenance.
---	---

Cancel button

	Press the Cancel button to cancel a scan in progress, or to cancel a series of scans when you are scanning from the ADF.
---	---

Scanner lamp setting

The scanner supports two modes of lamp operation:

- In Power Save mode, the scanner lamp times out and turns off automatically after about 15 minutes of inactivity. In this mode, the scanner is Energy Star compliant.
- In Instant Lamp On mode, the scanner lamp times out and turns off automatically after about 15 minutes of inactivity, but it remains warm and ready to scan.

To switch from Power Save mode to Instant Lamp On mode, select the **Enable Instant Lamp On** check box on the **Buttons** tab of the HP Scanner Tools Utility. To switch back to Power Save mode, clear the **Enable Instant Lamp On** check box.

Scanner software

The scanner comes with an assortment of scanning and document-management programs, including:

- [HP Smart Document Scan Software](#)
- [HP Document Copy Utility](#)
- [HP Scanner Tools Utility](#)

For more information and detailed descriptions of the software from other manufacturers that is included with the scanner, see the printed Setup and Support Guide that came with the scanner.

HP Smart Document Scan Software



HP Smart Document Scan Software guides you through the scanning process. To open the software, double-click the **HP Smart Document Scan Software** icon on the desktop. For more information, see [Scan from HP Smart Document Scan Software](#).

Main Window

The Main Window is displayed when you open the HP Smart Document Scan software. Use this window to complete the following tasks:

- **Start a scan:** Load the original in the document feeder, select a profile, and then click **Scan**. The scan will be completed using the settings associated with the selected profile.
- **Work with profiles:** Create and modify profiles to specify the scanner settings and the actions to take on your scanned documents.

Scan Progress Window

The Scan Progress Window opens when you start a scan. Use this window to complete the following tasks:

- View thumbnails of the pages as they are scanned
- Scan more pages
- Rescan pages individually
- Edit pages individually by using the crop, rotate, and deskew tools
- Reorganize or delete pages
- Complete the scan and process the document

For more information, see the HP Smart Document Scan Software Help.

HP Document Copy Utility

The HP Document Copy utility processes scan copy requests. To use the utility, do one of the following:

- Press the **Copy** () button on the scanner front panel.
The scanned pages are sent directly to the currently selected printer.
- Click **Start**, point to **Programs** or **All Programs**, point to **HP**, point to **Scanjet**, point to **N8400 series**, and then click **Document Copy**.
Select print settings in the **HP Document Copy** dialog box.

HP Scanner Tools Utility

Use the HP Scanner Tools Utility to assign profiles to quick start buttons, to choose which profiles are selectable on the scanner front panel, and to view information about scanner settings, status, and maintenance.



To open the utility, do one of the following:

- Double-click the **HP Scanner Tools Utility** icon on the desktop.
- Press the **Tools** () button on the scanner front panel.
- Click **Start**, point to **Programs** or **All Programs**, point to **HP**, point to **Scanjet**, point to **N8400 series**, and then click **Scanner Tools Utility**.

Use the **Buttons** tab to assign HP Smart Document Scan Software profiles to quick start buttons for direct access from the scanner front panel. For more information, see [Set up scan profiles](#).

Also use the **Buttons** tab to configure the behavior of the buttons on the scanner front panel and to change the lamp setting.

Use the **Profiles** tab to choose the HP Smart Document Scan Software profiles that are selectable from the scanner front panel.

Use the **Maintenance** tab to view the scanner usage and maintenance history and to run a test scan pass.

Where to get additional information

Several sources of information describe using the scanner and the scanning software.

Setup and Support Guide

Use the printed Setup and Support Guide that came with the scanner to set up and connect the scanner, test the installation, and troubleshoot installation problems.

User Guide

This scanner User Guide is the primary source for scanner information. It provides information about using, maintaining, and troubleshooting the scanner.

To open the User Guide in the installed (system) language, follow these steps:

- ▲ Click **Start**, point to **Programs** or **All Programs**, point to **HP**, point to **Scanjet**, point to **N8400 series**, and then click **User Guide**.

To open the User Guide in another language, follow these steps:

1. Insert the HP Scanning Software CD that came with the scanner into the computer CD drive.
Wait for the installation dialog box to display.
2. Click **View or print guides**.
A list of languages is displayed.
3. Click the language that you want.

To print one or more User Guide topics, follow these steps:

1. Select a topic name on the **Contents** tab or display that topic, and then click **Print** on the tool bar.
2. In the **Print Topics** dialog box, select an option:
 - To print a single topic, choose **Print the selected topic**.
 - To print a group of topics, choose **Print the selected heading and all subtopics**.
3. Click **OK**.
4. In the **Print** dialog box, select a printer, specify printing options, and then click **Print**.

 **TIP:** To print the entire user guide, select the highest-level topic in the **Contents** tab and then choose the **Print the selected heading and all subtopics** option.

HP Smart Document Scan Software Help

The HP Smart Document Scan Software Help explains how to use HP Smart Document Scan Software features such as creating and editing profiles.

To open HP Smart Document Scan Software Help, double-click the **HP Smart Document Scan Software** icon on the computer desktop, and then click **Help** on the menu bar.

HP Scanner Tools Utility help

The HP Scanner Tools Utility help explains the scanner settings, information about scanner status and maintenance, how to assign functionality to quick start buttons, and how to choose the profiles that you can select from the scanner front panel.

To open HP Scanner Tools Utility help, press the **Tools** button on the scanner front panel, and then click **Help** in the HP Scanner Tools Utility dialog box.

Technical Resources

Visit www.hp.com/support for a technical white paper on working with scan profiles across multiple computers.

Accessibility

- [LCD Reader](#)
- [Control of the scanner buttons](#)

LCD Reader

The LCD Reader is a software program that outputs the changing of the scanner front panel display to the computer monitor. The LCD Reader enables accessibility software tools to express what is being shown on the scanner front panel.

To use the LCD Reader, follow these steps:

1. On your hard drive, navigate to the C:\Program Files\Common Files\Hewlett-Packard\Scanjet\N8400 directory.
2. To start the program, double-click **hplcd.exe**.

Control of the scanner buttons

To prevent buttons from being pushed accidentally, you can disable the buttons on the scanner front panel.

When the buttons are disabled, you always start scans and copies from the computer using scanning software. You can still press the **Cancel** button on the scanner front panel to stop a scan or copy and the **Power Save** button to put the scanner into Power Save mode.

To turn off the scanner buttons, follow these steps:

1. Open the HP Scanner Tools Utility.
2. On the **Buttons** tab, select the **Disable scanner buttons** check box.
To turn on the scanner buttons, clear the **Disable scanner buttons** check box.



NOTE: You must have administrative privileges on the computer to change the setting of this check box.

2 Scan and Copy

The following topics describe how to scan or copy originals using the scanner and the scanner software.

- [Basic scanning steps](#)
- [Basic copying steps](#)
- [Load originals](#)
- [Scan from the scanner front panel buttons](#)
- [Scan from HP Smart Document Scan Software](#)
- [Scan from other software programs](#)
- [Scan with one button press](#)

Basic scanning steps

The basic steps for scanning are:

1. Load the originals. For more information, see [Load originals](#).
2. Do one of the following:
 - Press a quick start button on the scanner front panel.
 - Use the arrows (←→) buttons to scroll through the list of HP Smart Document Scan Software profiles that are displayed on the scanner front panel, and then press the **Scan Document To** (📄) button to start scanning with the selected profile. For information about profiles, see [Set up scan profiles](#).
 - Open HP Smart Document Scan Software. For more information, see [Scan from HP Smart Document Scan Software](#).
 - Open another scanning software program. For more information, see [Scan from other software programs](#).

 **TIP:** If you select duplex scanning or copying and you load the originals into the automatic document feeder (ADF), the scanner processes both sides of a two-sided original at the same time.

Basic copying steps

The basic steps for copying are:

1. Load the originals. For more information, see [Load originals](#).
2. Use the **Number of Copies** (+ -) button on the scanner front panel to select the number of copies, and then press the **Copy** (🖨️) button. The copies are printed with the current copy settings.

 **NOTE:** If you want to change the copy settings, start the copy from the HP Document Copy software.

 **TIP:** You can configure HP Document Copy to always prompt for copy settings before starting to print. For information, see the HP Scanner Tools Utility help.

Load originals

- [Place an original on the scanner glass](#)
- [Load paper into the document feeder](#)

Place an original on the scanner glass

Place items that do not meet the specifications for the automatic document feeder (ADF) directly onto the scanner glass.

Minimum size:	Any size
Maximum size:	215.9 mm x 355.6 mm (8.5 inches x 14 inches)

Place the original face down on the scanner glass, as indicated by the reference mark.

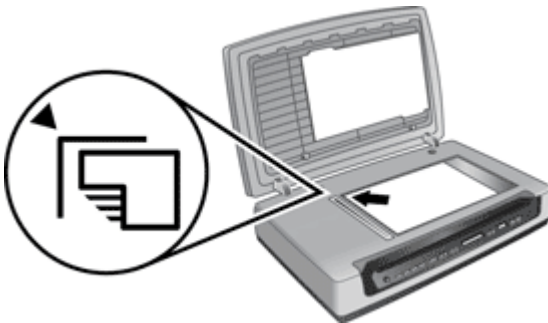



Load paper into the document feeder

The scanner document feeder is rated to process paper that meets the following specifications:

Minimum size:	148 mm x 148 mm (5.8 inches x 5.8 inches)
Maximum size when long-page support is <i>disabled</i> :	215.9 mm x 355.6 mm (8.5 inches x 14 inches)
Maximum size when long-page support is <i>enabled</i> :	215.9 mm x 863.6 mm (8.5 inches x 34 inches)
Minimum weight:	49 g/m ² (13 lb)
Maximum weight:	120 g/m ² (32 lb)

The paper capacity of the document feeder is 100 sheets of 75 g/m² (20 lb) paper.

 **NOTE:** HP does not recommend using the document feeder for photos, multipart forms, transparencies, or gum-backed pages.

 **CAUTION:** Avoid placing items that have sharp edges, paper clips, staples, wet glue, correction fluid, or other substances in the scanner. Document pages should not be curled, wrinkled, or stuck together.

 **NOTE:** For information on how to enable long-page support, see [Long pages](#).

To load paper into the document feeder, follow these steps:

1. Insert a multiple page document with the printed first page of the document facing up and with the top of the document into the feeder.



2. Adjust the paper guides to center the original. Make sure the paper guides touch the edges of the original.

Scan from the scanner front panel buttons

To scan from the scanner front panel buttons, do one of the following:

- Press a quick start button on the scanner front panel.
- Use the arrows (←→) buttons to scroll through the list of HP Smart Document Scan Software profiles that are displayed on the scanner front panel, and then press the **Scan Document To**  button to start scanning with the selected profile.

Scan from HP Smart Document Scan Software

You can start a scan from the HP Smart Document Scan Software.

1. Do one of the following:
 - Double-click the **HP Smart Document Scan Software** icon on the computer desktop.



- Click **Start**, point to **Programs** or **All Programs**, point to **HP**, point to **Scanjet**, and then click **HP Smart Document Scan Software**.
2. Select a profile, and then click **Scan**.

 **TIP:** A description of the selected profile is displayed below the list.

3. Follow the onscreen instructions to complete the scan.

For more information, see the HP Smart Document Scan Software Help.

Scan from other software programs

You can scan an image or document directly into a software program if the program is ISIS or TWAIN compliant. Generally, the program is compliant if it has a menu option such as **Acquire**, **Scan**, **Import New Object**, or **Insert**. If you are unsure whether the program is compliant or what the option is, see the documentation for that program.

HP Smart Document Scan Software is an ISIS application.

ScanSoft PaperPort and I.R.I.S. Readiris Pro are TWAIN applications.

Scan with one button press

The standard process for using the HP Smart Document Scan Software to complete your scans is as follows:

1. Scan document pages.
2. Review the scanned document pages in the HP Smart Document Scan Software **Scan Progress Window**. Reorder, delete, and rescan pages as necessary.
3. Finish the scan by clicking **Done Scanning** in the **Scan Progress Window**.
4. The scanning software processes the scanned document pages according to the profile settings.

You can set up a profile that skips steps 2 and 3 of the standard process. After you select this profile, press the **Scan Document To** button on the scanner front panel or click **Scan** in the HP Smart Document Scan Software **Main Window**. The pages will be scanned and processed without further intervention.

In order for a scan to complete automatically, the selected HP Smart Document Scan Software profile must include the following settings:

- On the **Profile** tab, the **Enable document review and option to scan more pages** check box must be cleared.
- Additional settings on the **Destination** tab, such as disabling the **Show Save As** dialog box, might be required depending on the profile.

3 Set up scan profiles

An HP Smart Document Scan Software profile contains settings for scanning, processing, and saving or sending scanned documents. You can set up profiles for use with the **Scan Document To** button on the scanner front panel. The profiles provide a fast, efficient way to scan. You can configure each profile to perform specific scanning functions that you use often. For example, if you frequently need to scan originals at 200 dpi color to a searchable PDF file and e-mail that file to a co-worker, you can create a profile with the necessary settings to accomplish this task.

Use the HP Smart Document Scan Software to set up and modify profiles. Use the HP Scanner Tools Utility to assign profiles to quick start buttons and to choose which profiles are selectable from the scanner front panel.

 **NOTE:** You can choose up to 30 profiles that are selectable from the scanner front panel. If you have more than 30 profiles, choose the most frequently used profiles. You can access all profiles by scanning from the HP Smart Document Scan Software.

For information on how to configure an HP Smart Document Scan Software profile to complete a scan without user interaction, see [Scan with one button press](#).

- [Set up an HP Smart Document Scan Software profile](#)
- [Assign profiles to quick start buttons](#)
- [Choose profiles for display on the scanner front panel](#)
- [Import and export profiles](#)

Set up an HP Smart Document Scan Software profile

To create an HP Smart Document Scan Software profile, follow these steps:

1. To open HP Smart Document Scan Software, do one of the following:
 - Double-click the **HP Smart Document Scan Software** icon on the computer desktop.



- Click **Start**, point to **Programs** or **All Programs**, point to **HP**, point to **Scanjet**, and then click **HP Smart Document Scan Software**.
2. Click **New**.
The Create New Profile dialog box is displayed.

3. In the **Profile name** box, type the name you want or accept the default name.

 **NOTE:** The first 16 characters of the profile name can be displayed on the scanner front panel. It is a good idea to include the information that distinguishes this profile at the beginning of the profile name.

 **TIP:** You might want to set up the new profile based on an existing one. To do so, check the **Copy settings from profile** check box and select an existing profile from the list.

4. Click **Continue**.
The Profile Settings dialog box is displayed.
5. Select the settings for the profile.

For more information, see the HP Smart Document Scan Software Help.

Assign profiles to quick start buttons

Use the HP Scanner Tools Utility to assign an HP Smart Document Scan Software profile to a quick start button.

To assign a profile to a quick start button, follow these steps:

1. To open the HP Scanner Tools Utility, do one of the following:
 - Double-click the **HP Scanner Tools Utility** icon on the computer desktop.



- Press the **Tools** () button on the scanner front panel.
 - Click **Start**, point to **Programs** or **All Programs**, point to **HP**, point to **Scanjet**, point to **N8400 series**, and then click **Scanner Tools Utility**.
2. In the **Program to Launch** drop-down list for a button number, select **HP Smart Document Scan Software**.
 3. In the **Profile** drop-down list, select a profile.

 **NOTE:** If you select a program other than HP Smart Document Scan Software, the quick start button starts that program when you press the associated quick start button.

NOTE: You can modify all profile settings except for the profile name, and the quick start button keeps its assignment.

Choose profiles for display on the scanner front panel

Use the HP Scanner Tools Utility to choose the HP Smart Document Scan Software profiles that are selectable from the scanner front panel.

To choose the profiles that are displayed on the scanner front panel, follow these steps:

1. To open the HP Scanner Tools Utility, do one of the following:
 - Double-click the **HP Scanner Tools Utility** icon on the computer desktop.



- Press the **Tools** () button on the scanner front panel.
 - Click **Start**, point to **Programs** or **All Programs**, point to **HP**, point to **Scanjet**, point to **N8400 series**, and then click **Scanner Tools Utility**.
2. Click the **Profiles** tab.
3. In the **Available Profiles** list, select a profile, and then click **Add**.
4. Use the **Move Up** and **Move Down** buttons to arrange the profile sequence in the **Display Order** list.

The profiles are displayed in this order as you scroll through the profile list.

Import and export profiles

Profiles can be exported into and imported from an XML file so that administrators can set up profiles for a workgroup, users can transfer their profiles from one machine to another, and users can share custom profiles with each other.

For information on working with profiles across multiple computers, visit www.hp.com/support.

4 Care and maintenance

This section presents information about how to care for and maintain the scanner.

- [HP Scanner Tools Utility Maintenance tab](#)
- [Order maintenance and scanning supplies](#)
- [Clean the scanner glass](#)
- [Maintain the automatic document feeder \(ADF\)](#)
- [Remove the automatic document feeder from the scanner](#)

Occasional cleaning of the scanner helps ensure high-quality scans. The amount of care necessary depends upon several factors, including the amount of use and the environment. You should perform routine cleaning as necessary.

Routine cleaning and maintenance should include cleaning the scanner glass and the automatic document feeder (ADF).

-
- △ **CAUTION:** Avoid placing items that have sharp edges, paper clips, staples, wet glue, correction fluid, or other substances in the scanner. Document pages should not be curled, wrinkled, or stuck together.
-

HP Scanner Tools Utility Maintenance tab

The **Maintenance** tab of the HP Scanner Tools Utility displays the scanner usage and maintenance history. You can use this tab to record scanner maintenance.

To open the HP Scanner Tools Utility, press the **Tools** button on the scanner front panel.

For detailed information on using the HP Scanner Tools Utility, see the HP Scanner Tools Utility help.

Order maintenance and scanning supplies

You can purchase maintenance parts online. Items such as the HP paper-path cleaning cloth or the feed roller replacement kit are available for worldwide delivery.

1. Visit the HP scanner support Web site at www.hp.com/support.
2. Enter the scanner model number, and then press **Enter**.

Clean the scanner glass

To clean the scanner glass, follow these steps:

1. Disconnect the universal serial bus (USB) cable and power cable from the scanner.
2. Open the scanner lid.

3. Clean the glass by using a soft, lint-free cloth that has been sprayed with a mild glass cleaner.

△ **CAUTION:** Use only glass cleaner to clean the scanner glass. Avoid cleaners that contain abrasives, acetone, benzene, and carbon tetrachloride, all of which can damage the scanner glass. Avoid isopropyl alcohol because it can leave streaks on the glass.

Do not spray the glass cleaner directly on the glass. If too much glass cleaner is applied, the cleaner could leak under the glass and damage the scanner.

4. Dry the glass with a dry, soft, lint-free cloth.
5. When you have finished, reconnect the USB cable and power cable to the scanner.

 **NOTE:** For instructions about how to clean the underside of the scanner glass, visit www.hp.com/support. Follow the online instructions to select your country/region and language, select the option to see support and troubleshooting information, and then enter the scanner product name and model number.

Maintain the automatic document feeder (ADF)

The ADF requires periodic maintenance depending on the amount of use and the type of paper that is fed through it. Use an HP paper-path cleaning cloth to clean the ADF when vertical streaks appear in images scanned by the ADF, when paper used in the ADF is dusty or dirty, or when the environment is dusty. If you use the ADF several times per week, monthly cleaning is recommended. Set up a cleaning routine that is appropriate for the scanner.

Use the following methods to maintain the ADF:

- [Clean the paper path](#)
- [Clean the ADF window](#)
- [Clean the feed roller](#)
- [Replace the feed roller and separation pad](#)

Clean the paper path

If scanned images have streaks or scratches, use the HP paper-path cleaning cloth to clean the paper path.

To order more HP paper-path cleaning cloths, go to www.hp.com/support.

To clean the paper path, follow these steps:

1. Open the sealed HP paper-path cleaning cloth container, starting at the notch. Take care not to tear the cleaning cloth.
2. Remove the cleaning cloth and unfold it.
3. Place the unfolded cloth into the paper input tray.
4. Press the Tools () button on the scanner front panel to open the HP Scanner Tools Utility. Click the **Maintenance** tab.

5. Click the **Clean** button to feed the cloth through the scanner.

△ **CAUTION:** Wait two minutes for the components to dry before proceeding to the next step.

6. Place up to five pages of printed paper in the ADF. Scan and view the results.
7. If streaks still appear, repeat steps 3 through 6. The cleaning cloth can be cycled through the ADF up to five times.

Clean the ADF window

If streaks exist on scanned images, cleaning the ADF window might solve the problem. Use the following steps to clean the ADF window.

To order more HP paper-path cleaning cloths, go to www.hp.com/support.

To clean the ADF window, follow these steps:

1. Open the scanner lid.



2. Locate the ADF access door on the underside of the ADF.
3. Press the tabs on the door, and then pull the door toward you until it detaches from the ADF.



4. Locate the clear scan window inside the ADF and clean it with an HP paper-path cleaning cloth.
5. Locate the white strip on the inside of the access door and clean it.
6. Replace the ADF access door:
 - a. Position the door over the ADF opening.
 - b. Press the door into place until it both sides click shut.
7. Clean the clear scanning strip on the scanner bed. Wipe the clear area with an HP paper-path cleaning cloth, or a clean, dry, lint-free cloth.

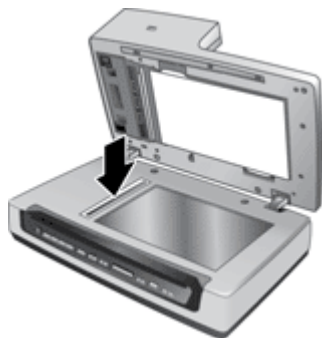

8. Close the scanner lid.
9. Use the ADF to scan up to five documents. View the results. If streaks still exist on the scanned images, call HP Customer Support.



Clean the feed roller

Clean the feed roller under either of the following conditions:

- Streaks on scans or paper jams occur repeatedly and cleaning the paper path does not help.
- The **Feeder Maintenance** section of the HP Scanner Tools Utility **Maintenance** tab indicates that maintenance is due.

To order more HP paper-path cleaning cloths or a feed roller replacement kit, go to www.hp.com/support.

To clean the feed roller, follow these steps:

1. Press the **Power** switch to the off position, and then disconnect the USB cable and power cable from the scanner.
2. Open the ADF hatch.



3. Lift the green lever to raise the feed roller to the vertical position.

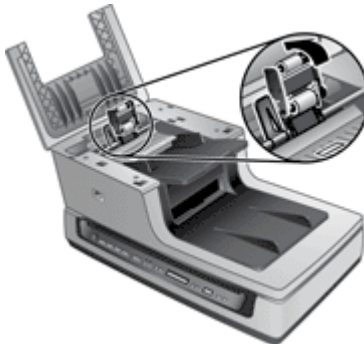

4. Inspect the separation pad that is located below the feed roller for wear and damage.

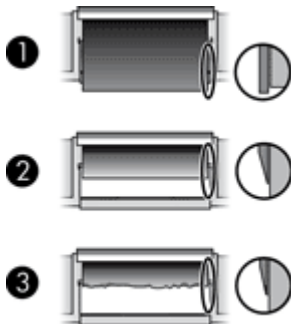

1	New separation pad
2	Worn separation pad
3	Damaged separation pad

 **NOTE:** The feed roller replacement kit includes extra separation pads. If the separation pad shows wear between feed roller replacements, then replace the separation pad as described in the installation instructions that were included with the replacement kit.

5. Use an HP paper-path cleaning cloth to clean each of the feed roller pads and the separation pad.

 **NOTE:** If you do *not* have an HP paper-path cleaning cloth, use a lint-free cloth that has been dampened with isopropyl alcohol.

6. Wipe the area around the small rubber pad to remove any paper dust.
7. Lower the green lever to return the feed roller to the working position.



8. Close the ADF hatch, and then reconnect the USB cable and power cable to the scanner.
9. Press the **Power** switch to the on position, and then update the scanner maintenance history:
 - a. Press the **Tools** () button on the scanner front panel to open on the HP Scanner Tools Utility. Click the **Maintenance** tab.
 - b. In the **Feeder Maintenance** section, click **Record Cleaning**.
For more information, see the HP Scanner Tools Utility help.

Replace the feed roller and separation pad

Replace the feed roller under either of the following conditions:

- Streaks on scans or paper jams occur repeatedly and cleaning the scanner does not help.
- The **Feed Roller and Separation Pad Maintenance** section of the HP Scanner Tools Utility **Maintenance** tab indicates that maintenance is due.

The feed roller replacement kit contains a feed roller, separation pads, and installation instructions. To order the replacement kit, go to www.hp.com/support.

To replace the feed roller and separation pad, follow these steps:

1. Press the **Power** switch to the off position, and then disconnect the USB cable and power cable from the scanner.
2. Open the ADF hatch, and then replace the feed roller and separation pad as described in the installation instructions that were included with the replacement kit.



NOTE: The feed roller replacement kit includes extra separation pads. If the separation pad shows wear between feed roller replacements, then replace the separation pad as described in the installation instructions that were included with the replacement kit.

3. Close the ADF hatch, and then reconnect the USB cable and power cable to the scanner.
4. Press the **Power** switch to the on position, and then update the scanner maintenance history:
 - a. Press the **Tools** () button on the scanner front panel to open on the HP Scanner Tools Utility. Click the **Maintenance** tab.
 - b. In the **Feed Roller and Separation Pad Maintenance** section, click **Record Replacement**.
For more information, see the HP Scanner Tools Utility help.

Remove the automatic document feeder from the scanner

If you need to remove the automatic document feeder (ADF) from the scanner, follow these steps:

1. Turn the thumbscrews on the connector until they are loose. Disconnect the accessory cable from the accessory cable port on the scanner.
2. Remove the ADF input tray.

3. Raise the scanner lid to the open position.

△ **CAUTION:** Do not attempt to uninstall the ADF in the closed position. The ADF must be uninstalled in the opened position. Keep fingers away from the ADF hinges.

4. Grasp the ADF by the sides.

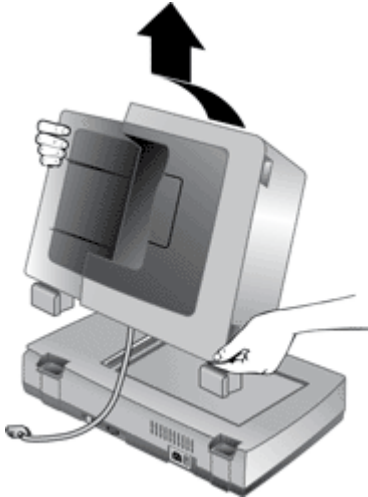

5. Lift the ADF upwards while slightly tilting it away from you until the hinge posts are pulled out of the sockets on the scanner bed.

5 Troubleshooting

This section contains solutions for common problems with the scanner.

- [Scanner error messages](#)
- [Scanner initialization or hardware problems](#)
- [Scanner operation problems](#)
- [Scanner buttons are not working correctly](#)
- [Automatic document feeder \(ADF\) problems](#)
- [Contact HP Support](#)

For additional troubleshooting, see the help for the HP scanning program that you are using. For more information, see [Where to get additional information](#).

Scanner error messages

The scanner displays status and error messages on the scanner front panel. For help responding to a scanner error message, see the appropriate topics below.

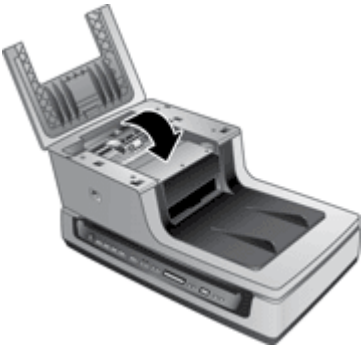
Scanner Error Message	Recovery Process
ADF Jam – Input Tray	Clear the jammed paper from the automatic document feeder (ADF) input tray. For instructions, see Clear jams from the ADF in the Troubleshooting section.
ADF Jam – Clean Out	Clear the jammed paper from the opening behind the ADF access door. For instructions, see Clear jams from the ADF in the Troubleshooting section.
ADF Jam – Output Tray	Clear the jammed paper from the automatic document feeder (ADF) output tray. For instructions, see Clear jams from the ADF in the Troubleshooting section.
Hatch Open	Close the automatic document feeder (ADF) hatch. Press down firmly on both sides until you hear a click. 

(continued)

Scanner Error Message	Recovery Process
Clean Out Open	<p>Replace the ADF access door by positioning the door over the ADF opening and pressing the door into place until both sides click.</p> 
Duplex Error	<p>Follow these steps to resolve the error:</p> <ol style="list-style-type: none"> 1. Close the program you are using to scan. 2. Press the Power switch to the off position. 3. Check the scanner cables to make sure that they are securely attached to the scanner. 4. Press the Power switch to the on position, and then try to scan. If the problem persists, contact HP Support.
Multipick Error	<p>The document feeder cannot pick up the paper or the paper is jammed. Follow these steps to resolve the error:</p> <ol style="list-style-type: none"> 1. Remove the paper from the document feeder. 2. Sort through the stack to make sure the sheets are not stuck together. 3. Make sure the paper meets the size and weight specifications, as specified in the scanner User Guide. 4. Replace the stack of originals and try again.
01	<p>Press the Power Save button to turn the scanner off, and then turn the scanner on again by pressing one of the front panel buttons. If the message is still displayed, contact HP Support. For more information, see <i>Contact HP Support</i>.</p>
02	<p>Press the Power Save button to turn the scanner off, and then turn the scanner on again by pressing one of the front panel buttons. If the message is still displayed, contact HP Support. For more information, see <i>Contact HP Support</i>.</p>
03	<p>Press the Power Save button to turn the scanner off, and then turn the scanner on again by pressing one of the front panel buttons. If the message is still displayed, contact HP Support. For more information, see <i>Contact HP Support</i>.</p>

(continued)

Scanner Error Message	Recovery Process
04	Follow these steps to resolve the error: <ol style="list-style-type: none">1. Check the USB connection between the scanner and the computer. For more help, see <i>Check the cables</i>.2. Verify that the scanner is correctly enumerated on the host. If not, try uninstalling and then reinstalling the software. For more information, see the <i>HP Scanjet N8400 series Setup and Support Guide</i>.3. If the problem persists, contact HP Support. For more information, see <i>Contact HP Support</i>.
05	Press the Power Save button to turn the scanner off, and then turn the scanner on again by pressing one of the front panel buttons. If the message is still displayed, contact HP Support. For more information, see <i>Contact HP Support</i> .
06	Press the Power Save button to turn the scanner off, and then turn the scanner on again by pressing one of the front panel buttons. If the message is still displayed, contact HP Support. For more information, see <i>Contact HP Support</i> .
07	Press the Power Save button to turn the scanner off, and then turn the scanner on again by pressing one of the front panel buttons. If the message is still displayed, contact HP Support. For more information, see <i>Contact HP Support</i> .

Scanner initialization or hardware problems

- [Scanner does not start](#)
- [Scanner has stopped working correctly](#)

Scanner does not start

If you receive an error message similar to “Scanner initialization failed” or “Scanner not found” when trying to use the scanner, follow these steps:

1. Close the scanning software, if it is open.
2. Disconnect the USB cable that connects the scanner to the computer.
3. Press the **Power** switch to the off position.
4. Shut down the computer operating system, turn the computer off, wait 60 seconds, and then turn the computer back on.
5. Press the **Power** switch to the on position.
6. Reconnect the USB cable that connects the computer and the scanner, making sure that the USB cable is connected to the back of the scanner correctly.

After 30 seconds, the scanner display should show **Ready**. If the display does not show **Ready**, see the printed Setup and Support guide that came with the scanner.

Scanner has stopped working correctly

If the scanner stops scanning, follow these steps. After each step, start a scan to see if the scanner is working. If the problem persists, proceed with the next step.

1. A cable might be loose. Ensure that both the USB cable and power supply are properly connected.
Use the cable that was included with the scanner. Another USB cable might not be compatible with the scanner.
2. Turn off the scanner, wait 60 seconds, and then turn the scanner back on.
3. Restart your computer.
4. Use the **Add/Remove** tool (in Windows Vista, the **Programs and Features** tool) from the **Control Panel** to uninstall the following programs:
 - HP Scanjet N8400 series Document ISIS/TWAIN
 - HP Scanjet N8400 series Utilities
5. Reinstall using the HP Scanning Software CD that came with your scanner. When you insert the CD, an installation dialog box launches automatically.

Scanner operation problems

- [Scanner will not turn on](#)
- [Scanner lamp stays on](#)
- [Scanner does not scan right away](#)
- [Scanner scans only one side of a double-sided page](#)
- [Scanned image is fuzzy](#)
- [Scanned pages are out of order at the scan destination](#)
- [Scanner is scanning items very slowly](#)
- [The image is completely black or completely white](#)
- [Scanned images are not straight](#)
- [Vertical white stripes appear on the printed page](#)
- [Scanner glass is dirty](#)
- [Scan files are too large](#)

Scanner will not turn on

If the scanner will not turn on when you press the front panel scanner buttons, verify the following:

- The scanner power switch might be turned off. Be sure the power switch located on the back of the scanner is turned ON.
- The scanner may have been unplugged. Check to see that the power cable has not become disconnected from the scanner or unplugged from the power source.
- Check to see that the automatic document feeder (ADF) cable has not become disconnected from the scanner.
- The buttons might be disabled in the HP scanning software. Verify the **Disable front panel buttons** setting in the HP Scanner Tools Utility.

Scanner lamp stays on

The scanner lamp should time out and turn off automatically after a period of inactivity (about 15 minutes). This is the Power Save mode.

If the scanner lamp remains on after a long period of inactivity, turn off the scanner, wait 30 seconds, and then turn the scanner back on.

Scanner does not scan right away

Make sure the power switch on the back of the scanner is turned ON.

If the scanner has not been used for a while, the scanner lamp might need to go through a warm-up period before scanning can begin. If the scanner lamp needs to warm up, it takes a moment after starting the software or pressing a scanner button for scanning to begin.

You can enable Instant Lamp On mode in the HP Scanner Tools Utility.

Scanner scans only one side of a double-sided page

Select the **Duplex** setting in the scanning or copy software.

Scanned image is fuzzy

It is important that the item you scan comes in close contact with the scanner glass. If the resulting scanned image is not clear, check to see that the item is in full contact with the scanner glass.

Check for any obstructions in the scanner paper path and make sure the paper width guides are positioned appropriately. Try another scan.

Clean the scanner glass as described in the **Care and maintenance** section.

Scanned pages are out of order at the scan destination

Insert a multiple page document with the printed first page of the document facing up and with the top of the document into the feeder.

Scanner is scanning items very slowly

- If you are scanning to edit text, the optical character recognition (OCR) software program causes the scanner to scan more slowly, which is normal. Wait for the item to scan.
- The resolution might be set too high. Reset the resolution to a lower level. The scanner software automatically selects the resolution to provide the best balance between image quality and file size.

The image is completely black or completely white

The item might not be placed correctly on the scanner glass. Make sure that the item you are trying to scan is placed face down on the glass and the lid is closed. If scanning from the ADF, check the paper orientation.

Scanned images are not straight

The item might have shifted when you closed the lid. Straighten the original on the scanner glass, and then scan again.

Verify that the document feeder guides are centered on the scanner and set to an appropriate width for the original being scanned. Make sure the paper guides touch the edges of the original.

Vertical white stripes appear on the printed page

The destination printer might be out of toner or ink. Scan a different original to the same printer to see if the issue lies with the printer.

If the second original has the same problem, clean the scanner glass as described in *Care and maintenance* .

Scanner glass is dirty

Clean the scanner glass under the following conditions:

- Ink is on the glass
- Fingerprints are on the glass
- Documents or other items placed on the glass have an excessive amount of dust or dirt on them
- Smudges or other marks appear on scanned images
- Haze or dust is on the glass

Allow the glass to dry thoroughly before scanning another image.

For more details, see [Care and maintenance](#).

Scan files are too large

If the saved scans have very large file sizes, try the following:

- Verify the scan resolution setting:
 - 200 dpi is sufficient for storing documents as images.
 - For most fonts, 300 dpi is sufficient for using optical character recognition (OCR) to create editable text.
 - For Asian fonts and small fonts, 400 dpi is the recommended resolution.

Scanning at a higher resolution than necessary creates a larger file with no additional benefit.

- Color scans create larger files than do black and white scans.
- If you are scanning a large number of pages at one time, consider scanning fewer pages at a time to create more, smaller files.
- Use the Kofax VirtualReScan software to reduce the number of random gray or black dots that appear on a scanned image. Eliminating these dots can create a smaller file.

Scanner buttons are not working correctly

- [Buttons do not work](#)
- [An unexpected program opens when a button is pressed](#)
- [Wrong profile is used when a quick start button is pressed](#)

Buttons do not work

After each step, press a button to see if it is working correctly. If the problem persists, proceed with the next step.

1. The buttons might be disabled in the HP scanning software. Verify the **Disable front panel buttons** setting in the HP Scanner Tools Utility.
2. A cable might be loose. Ensure that the USB cable and the power supply are securely connected.
3. Turn off the scanner, wait 30 seconds, and then turn the scanner back on.
4. Restart your computer.
5. If the problem persists, the buttons might be disabled outside of the HP scanning software. Try the following procedure:
 - a. Open **Control Panel**, select **Scanners and Cameras**, and then select your scanner model from the list.
 - b. Examine the buttons setting for your scanner:
 - Windows 2000: Ensure that the **Disable Device Events** option is not selected.
 - Windows XP and Vista: Ensure the **Take No Action** option is not selected.

An unexpected program opens when a button is pressed

Depending on the HP scanning software installed on the computer, an unexpected program might open when a profile is selected and a button is pressed.

After each step, press a button to see if it is working correctly. If the problem persists, proceed with the next step.

1. Verify that the expected program is installed on the computer by looking at the **Start** menu.
If the program is not installed, then use the program CD to install the program.
2. If the problem persists, the buttons might be assigned outside of the HP scanning software. Try the following procedure:
 - a. Open **Control Panel**, select **Scanners and Cameras**, and then select your scanner model from the list.
 - b. Ensure that the **Start this program** option is selected and that the correct application is selected in the drop-down list.

Wrong profile is used when a quick start button is pressed

Use the HP Scanner Tools Utility to check which HP Smart Document Scan Software profiles are assigned to the quick start buttons. If necessary, reset the profile assigned to the button.

For more information, see the HP Scanner Tools Utility help.

Automatic document feeder (ADF) problems

Use this section to help resolve issues that might occur when scanning from the ADF.

- [Paper jamming, skewing, misfeeds, or multiple-page feeds](#)
- [Paper does not feed from the ADF](#)
- [The bottom of the scanned image is cut off](#)
- [The scanned images have streaks or scratches](#)
- [An item loaded in the ADF jams repeatedly](#)
- [Clear jams from the ADF](#)

Paper jamming, skewing, misfeeds, or multiple-page feeds

- If the pages look skewed as they feed into the automatic document feeder, check the resulting scanned images in the software to ensure that they are not skewed.
- The pages might not be placed correctly. Straighten the pages and adjust the paper guides to center the stack.
- The ADF input tray or output tray might contain more than the maximum number of pages. Load fewer pages in the input tray, and remove pages from the output tray.
- If misfeeds occur frequently, perform document feeder maintenance. For information on the following tasks, see *Care and maintenance*.
 - Clean the ADF.
 - If the problem persists, clean the feed roller.
 - If the problem persists, replace the feed roller.
- Remove any objects that are on the ADF lid.
- Check to see that the ADF lid is fully closed.

Paper does not feed from the ADF

- The ADF lid might not be securely latched. Open the ADF lid and then close it by pressing firmly.
- A problem with the ADF hardware might exist. Use the following procedure to test the ADF:
 - Disconnect the USB cable and the power cable from the scanner. Check that the power cable is still connected to the power source.
 - Ensure that the accessory cable is connected to the scanner accessory port, and that the ADF has at least two pieces of paper in the input tray.
 - Reconnect the power cable to the scanner, and then turn the scanner on.
 - Try to scan another page through the ADF.

If the ADF does not feed paper, contact HP Customer Support.

The bottom of the scanned image is cut off

By default, the scanner can scan media that is up to 355.6 mm (14 inches) long. For longer pages, the end of the document is not included in the scanned image.

Verify that you have specified an appropriate page size in the scanning software.

For information on how to enable scanning of media up to 863.6 mm (34 inches), see the **Advanced Technical Features** section.

The scanned images have streaks or scratches

After each step, try another scan to see if the streaks or scratches are still apparent. If so, then try the next step. For information on cleaning the scanner, see the **Care and maintenance** section.

1. Check that the originals are clean and unwrinkled.
2. Clean the scanner glass.
3. Use a cleaning cloth in the ADF.
4. Clean the feed roller.
5. Clean the ADF window.

An item loaded in the ADF jams repeatedly

- The item does not meet the guidelines for the ADF. For more information, see [Load originals](#).
- The item might have something on it, such as staples or self-adhesive notes on the original that must be removed.
- Make sure the paper guides touch the edges of the original.
- If jams occur frequently, perform document feeder maintenance. For information on the following tasks, see *Care and maintenance*.
 - Clean the ADF.
 - If the problem persists, clean the feed roller.
 - If the problem persists, replace the feed roller.

Clear jams from the ADF

If the ADF jams, the scanner display indicates where the jam occurred.

Before you contact HP Support for help to resolve jams in the scanner feeder, do all of the following:

- Follow all of the procedures that are described in this section.
- Inspect your originals to be sure that they are in good condition, they are not sticking together, and they are free from foreign objects such as staples, paper clips, or self-adhesive papers.
- Inspect the entire paper path to ensure that no foreign objects are caught in the feeder.
- Clean the feed roller as described in *Care and Maintenance*.
- Inspect the separation pad and the feed roller. Replace any damaged parts.

Clear a jam from the start of the paper path

1. Remove any loose pages from the ADF input tray. Remove the input tray from the ADF.
2. Open the ADF hatch.

3. Lift the green lever to raise the feed roller to the vertical position, and then gently remove the jammed page.

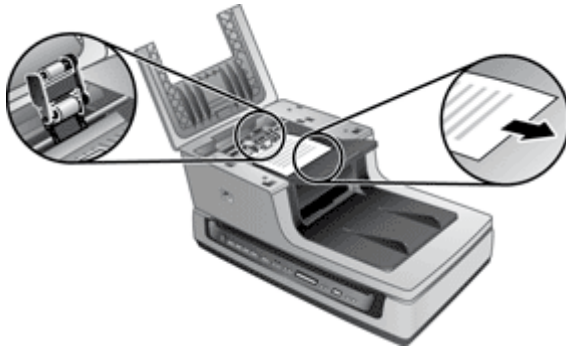

4. Lower the green lever to return the feed roller to the working position, and then close the ADF hatch. Press down firmly on both sides until you hear a click.



5. Put the input tray on the ADF. Reload the unscanned pages in the ADF input tray.
6. Resume scanning.

Clear a jam at the end of the paper path

1. Remove any loose pages from the ADF input tray.
2. Gently pull the jammed page out of the ADF in the opposite direction from which the page fed into the ADF.



3. If the jammed page still cannot be removed, lift the lid to its fully open position, loosen the jammed page from the roller on the underside of the lid, and then gently pull the page out of the ADF.

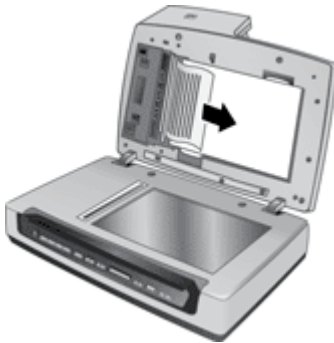

4. Close the ADF hatch. Press down firmly on both sides until you hear a click.
5. Re-stack the unscanned pages and reload them into the ADF.
6. Resume scanning.

Remove a paper jam within the ADF

1. Remove any loose pages from the ADF input tray.
2. Open the scanner lid.



3. Locate the ADF access door on the underside of the ADF.
4. Press the tabs on the door, and then pull the door toward you until it detaches from the ADF.

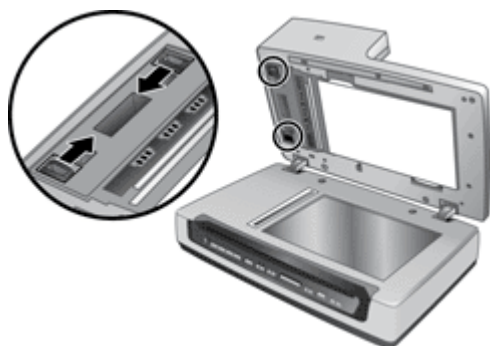

5. Remove any paper inside the ADF.
6. Replace the ADF access door by positioning the door over the ADF opening and pressing the door into place until both sides click.
7. Close the scanner lid.
8. Reload the unscanned pages in the ADF input tray.
9. Resume scanning.

Contact HP Support

For support contact information, see the printed Setup and Support Guide that came with the scanner or visit www.hp.com/support.

6 Advanced technical features

Experienced document management professionals might be interested in the following scan features. These features are available from any document TWAIN or ISIS application that allows you to modify the scan settings in its user interface.

- [Long pages](#)
- [Color dropout](#)
- [Misfeed \(Multipick\) Detection](#)

Long pages

By default, the automatic document feeder (ADF) accepts a stack of originals up to 215.9 mm x 355.6 mm (8.5 inches x 14 inches). You can choose to scan single pages up to 215.9 mm x 863.6 mm (8.5 inches x 34 inches) through the ADF.

 **NOTE:** If the scanner is set to scan long pages and a page jams, up to 864 mm (34 inches) of document pages can be wrinkled as a result of the jam. Therefore, select scan profiles that specify long pages only when you are scanning pages longer than 355.6 mm (14 inches).

To enable long-page scans in an HP Smart Document Scan Software profile, follow these steps:

1. Open the HP Smart Document Scan Software.
2. Select a scan profile, and then click **Edit**.
3. Set the page size:
 - ▲ On the **Scan** tab of the **Profile Settings** dialog box, select **Custom** in the **Size** drop-down list, and then type the actual page dimensions, up to 215.9 mm x 863.6 mm (8.5 inches x 34 inches), in the **Width** and **Height** boxes.

 **TIP:** Alternatively, you can select **Maximum** in the **Size** drop-down list. The resulting scanned image size will be 215.9 mm (8.5 inches) wide and the actual page length up to 863.6 mm (34 inches) long.

 **NOTE:** Some scanning and destination applications might not support long pages.

Color dropout

You can filter out specific colors from a document scan, for example, you can remove colored lines on a form. Removing colors from the scan reduces the scan file size and can improve the accuracy of optical character recognition (OCR). You can select to filter out one color channel (red, green, or blue).

To eliminate a color from a scan in an HP Smart Document Scan Software profile, follow these steps:

1. Open the HP Smart Document Scan Software.
2. Select a scan profile, and then click **Edit**.
3. Configure color dropout:
 - a. On the **Scan** tab of the **Profile Settings** dialog box, click **Advanced Settings**.
 - b. On the **Color Dropout** tab of the **Properties** dialog box, select the channel to be dropped out.

Misfeed (Multipick) Detection

The Misfeed (Multipick) Detection feature stops the scan or copy process if it senses that multiple pages are fed into the scanner at one time. This feature is enabled by default.

To disable the Misfeed (Multipick) Detection feature in an HP Smart Document Scan Software profile, follow these steps:

1. Open the HP Smart Document Scan Software.
2. Select a scan profile, and then click **Edit**.
3. On the **Scan** tab of the **Profile Settings** dialog box, click **Advanced Settings**.
4. On the **More** tab of the **Properties** dialog box, clear the **Enable** check box.

Index

A

- accessibility 9
- ADF
 - clean window 19
 - cut-off images 32
 - feeding, troubleshoot 32
 - jams 33
 - maintain 18
 - maintenance 18
 - skewed pages 32
 - streaks, troubleshoot 33
- applications
 - scan from 13

B

- black scans, troubleshoot 29
- buttons
 - troubleshoot 31

C

- clean
 - ADF window 19
 - feed roller 20
 - paper path 18
 - scanner glass 17
- cleaning cloth 18
- Color dropout 37
- copy
 - select number of copies 10
- crooked images,
 - troubleshoot 30
- customer support 36
- cut-off images, troubleshoot 32

D

- disable scanner buttons 9
- document feeder
 - load paper 11
- double-sided scans
 - troubleshoot 29

E

- editable text 3
- export profiles 16

F

- features
 - color dropout 37
 - long-page support 37
 - Misfeed (Multipick)
 - Detection 37
- feed roller
 - clean 20
 - replace 23
- file management 3
- fuzzy images, troubleshoot 29

G

- glass, clean 17

H

- help 8
- HP Document Copy
 - uses for 7
- HP paper-path cleaning
 - cloth 18
- HP Scanner Tools Utility
 - assign profiles to quick start
 - buttons 15
 - help 9
 - Maintenance tab 17
 - uses for 7
- HP Smart Document Scan Software
 - features 3
 - help 8
 - scan from 12
 - set up profiles 14
 - troubleshoot 31

I

- import profiles 16
- ISIS-compliant programs
 - scan from 13

J

- jams, ADF 33

L

- lamp
 - troubleshoot 6
- lamp, scanner 29
- LCD Reader 9
- lines
 - troubleshoot 30
- load originals 11
- long-page support 37

M

- maintenance
 - clean feed roller 20
 - clean paper path 18
 - HP Scanner Tools Utility
 - Maintenance tab 17
 - replace feed roller 23
- media jams, ADF 33
- Misfeed (Multipick) Detection
 - feature 37

N

- number of copies
 - select 10

O

- OCR 3
- onscreen help 8
- order
 - feed roller replacement 23

P

- page management 3
- pages out of order 29
- paper jams, ADF 33
- paper path
 - clean 18
- parts
 - order 23
- Power Save mode 6
- power-on, troubleshoot 28
- profiles
 - assign to quick start
 - buttons 15
 - features 3

- import and export 16
 - select 10
 - set up 14
- programs
 - scan from 13

Q

- quick start buttons
 - assign profiles 15
 - troubleshoot 31

R

- replace feed roller 23
- reset the scanner 27

S

- scan
 - files too large 30
 - from HP Smart Document Scan Software 12
 - from other programs 13
 - select profiles 10
 - with one button press 13
- scan profiles
 - troubleshoot 31
- scanner
 - lamp, troubleshoot 29
 - power-on, troubleshoot 28
- scanner glass
 - place original 11
- scanner glass, clean 17
- scanner lamp
 - troubleshoot 6
- screen reader 9
- separation pad
 - replace 23
- Setup and Support Guide 8
- skewed pages, troubleshoot 32
- software
 - features 3
 - help 8
 - uninstall and reinstall 28
- speed, troubleshoot 29
- streaks, troubleshoot 33
- stripes
 - troubleshoot 30
- support 36
- support guide 8

T

- technical support 36
- text, editable 3

- troubleshoot
 - ADF 32
 - ADF feeding 32
 - black scans 29
 - buttons 31
 - crooked images 30
 - cut-off images 32
 - double-sided scans 29
 - fuzzy images 29
 - HP Smart Document Scan Software 31
 - jams, ADF 33
 - lamp stays on 6, 29
 - large scan files 30
 - page order 29
 - power-on 28
 - quick start buttons 31
 - reset the scanner 27
 - skewed pages 32
 - speed 29
 - stops working 28
 - streaks 33
 - uninstall and reinstall software 28
 - warm-up time 6
 - white lines 30
 - white scans 29
- TWAIN-compliant programs
 - scan from 13

U

- uninstall and reinstall software 28
- User Guide 8

V

- vertical white stripes
 - troubleshoot 30

W

- warm-up time 6
- Web sites
 - replacement parts 23
- white scans, troubleshoot 29
- white stripes
 - troubleshoot 30