

Installation Instructions

Fuel Tank Replacement Kit 45494KIT & 45495KIT

For Derby Colts & Stallions

⚠ WARNING

Before beginning any service work turn off the PTO, set the parking brake, turn off the ignition, and disconnect the spark plug wire(s).

REMOVAL

1. Remove the bumper from the machine. Save the hardware.
2. Remove the cross bar and mounts from the fuel tanks. Save the hardware.
3. Remove the fuel supply hose from the bottom of the fuel tank and drain all remaining fuel into a suitable container.

⚠ WARNING

Gasoline is highly flammable and must be handled with care. Do not allow open flame, smoking or matches in the area.

4. Remove the fuel tank from the machine and save all of the hardware. Discard the fuel tank and the rubber grommets.
5. Cut the tie wraps that fasten the fuel supply hose to the frame rail.
6. Cut 10" (25,4cm) from the fuel supply hose and wire loom covering. Route on the inside of the frame rail.

INSTALLATION

1. Install the iso mounts in the front inserts of the new tank.
2. Install the new tank mount bracket onto the existing tank mount plate and secure with the supplied hardware. See Figure 1 below for mount and hardware orientation. Make sure to use the holes to mount the bracket.
3. Install the fuel tank onto the machine and secure with all of the saved hardware.
4. Reconnect the fuel supply hose to the new fitting on the inside surface of the tank and secure with the saved hose clamp. Secure the fuel supply hose to the frame rail, making sure not to contact the pump cooling fan.
5. Reinstall the cross bar and mounts onto the new tank and secure with the saved hardware.
6. Reinstall the bumper and secure with the saved hardware.

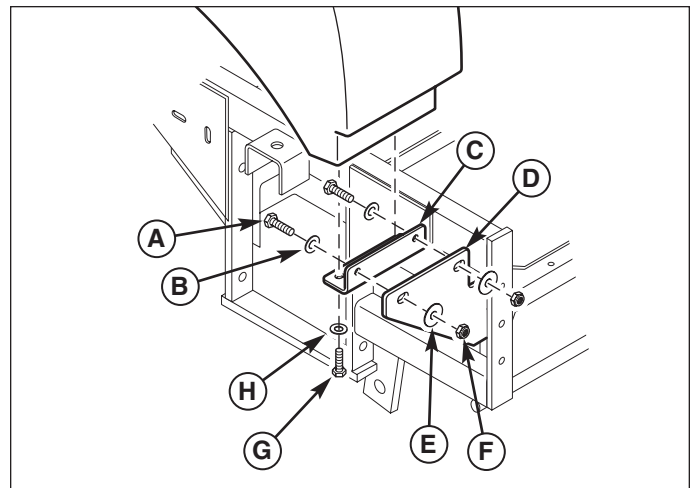

Figure 1. Fuel Tank Installation

- | | |
|------------------------|-------------------------|
| A. 3/8" x 1-1/4" Bolts | E. 3/8" Fender Washers |
| B. 3/8" SAE Washers | F. 3/8" Nylon Lock Nuts |
| C. Tank Mount Bracket | G. 5/16" x 1-1/4" Bolts |
| D. Tank Mount Plate | H. 5/16" SAE Washers |