

RSA-1200LX User Manual

Version 1.0
2008/04/25

This document contains information highly confidential to RoyalTek Company LTD (RoyalTek). It is provided for the sole purpose of the business discussions between supplier and RoyalTek and is covered under the terms of the applicable Non-Disclosure Agreements. Disclosure of this information to other parties is prohibited without the written consent of RoyalTek.

Prepared by RoyalTek Company LTD.

4F, 188, Wen Hwa 2nd Rd., Kuei Shan.

Tao Yuan 33377, Taiwan

TEL: 886-3-3960001

FAX: 886-3-3960065

<http://www.royaltek.com/contact>

Figure List.....	II
Table List.....	III
1 Introduction	4
1.1 Product applications.....	4
1.2 Product Picture.....	5
1.3 RSA-1200LX System Block Diagram	5
1.4 RSA-1200LX Technique Specification	6
1.5 Application Circuit	8
1.6 Mechanical Layout	9
1.7 Hardware interface	10
2 Software Interface.....	12
2.1 NMEA V3.0 Protocol.....	12
2.1.1 GGA-Global Positioning System Fixed Data	12
2.1.2 GLL-Geographic Position –Latitude/Longitude.....	13
2.1.3 GSA-GNSS DOP and Active Satellites	14
2.1.4 GSV-GNSS Satellites in View.....	14
2.1.5 RMC-Recommended Minimum Specific GNSS Data.....	15
2.1.6 VTG-Course Over Ground and Ground Speed.....	16
3 Package	17
3.1 Package Specification	17
4 Contact Information Section.....	17
5 Revision History	17

Figure List

Figure 1-1 RSA-1200LX Front View	5
Figure 1-2 RSA-1200LX Bottom View.....	5
Figure 1-3 System Block Diagram	5
Figure 1-4 Application Circuit Reference	8
Figure 1-5 Mechanical Layout	9
Figure 1-6 Hardware Interface	10
Figure 3-1 Package Specifications	17

Table List

Table 1-1 Technical Specifications	6
Table 1-2 Definition of Pin assignment.....	10
Table 2-1 NMEA-0183 Output Messages.....	12
Table 2-2 GGA Data Format	12
Table 2-3 Position Fix Indicators	13
Table 2-4 GLL Data Format	13
Table 2-5 GSA Data Format.....	14
Table 2-6 Mode 1.....	14
Table 2-7 Mode 2.....	14
Table 2-8 GSV Data Format.....	15
Table 2-9 RMC Data Format	15
Table 2-10 VTG Data Format.....	16

1 Introduction

RoyalTek RSA-1200LX low power and small form factor board is the newest generation of RoyalTek smart antenna GPS module. The smart antenna GPS module is powered by SiRF Star III technology and RoyalTek proprietary navigation algorithm that providing you more stable navigation data. Parallel design is the major new feature of RSA-1200LX.

The smallest form factor and parallel design is the best choice to be embedded in a portable device and receiver like PND, mobile phone, car holder, personal locator, digital camera and vehicle locator. The excellent sensitivity of RSA-1200LX gets the great performance when going though the urban canyon and foliage

Product Features

- 2 20 parallel channels
- 2 Extreme fast TTFF at low signal level
- 2 Operable from 3.3V/48mA continuous mode.
- 2 Wire to board connector
- 2 TCXO design
- 2 0.1 second reacquisition time
- 2 Small form factor with embedded SiRF Star III single chip technology.
- 2 NMEA-0183 compliant protocol/custom protocol.
- 2 4 Mbits Flash Memory
- 2 Enhanced algorithm for navigation stability
- 2 Excellent sensitive for urban canyon and foliage environments.
- 2 SBAS (WAAS, EGNOS and MSAS) support
- 2 Auto recovery while RTC crashes
- 2 Trickle power supported

1.1 Product applications

- 2 Automotive navigation
- 2 Personal positioning and navigation
- 2 Marine navigation
- 2 Timing application

1.2 Product Picture
RSA-1200LX



Figure 1-1 RSA-1200LX Front View



Figure 1-2 RSA-1200LX Bottom View

1.3 RSA-1200LX System Block Diagram

System block diagram description :

- a. External antenna.
- b. 4 Mega bits flash memory
- c. 6 pin I/O pin

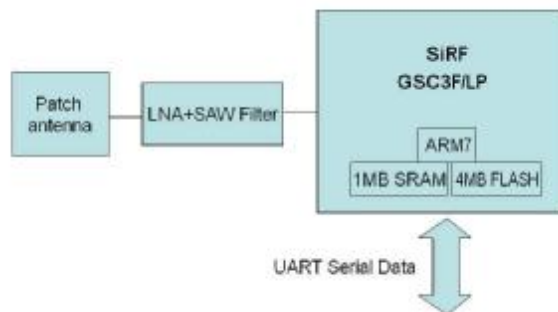

Figure 1-3 System Block Diagram

1.4 RSA-1200LX Technique Specification

Table 1-1 Technical Specifications

Impedance : 50Ω

No	Function	Specification
GPS receiver		
1	Chipset	SiRF Star III, GSC3f/LPX (Digital, RF in a single package)
2	Frequency	L1 1575.42MHz.
3	Code	C.A. Code.
4	Channels	20 parallel
5	Chipset Sensitivity	-159dBm
6	Cold start	35 sec @ open sky
7	Warm start	35 sec @ open sky
8	Hot start	1 sec @ open sky
9	Reacquisition	0.1sec typical
10	Position accuracy	10meters at 2D RMS.
11	Maximum altitude	18000 m
12	Maximum velocity	514 m/s
1	Trickle power mode	40mA @Average TBD
2	Update rate	Continuous operation: 1Hz
3	Testability	It shall be able to be tested by SiRF test IV and single channel simulator.
4	Protocol setup	It shall store the protocol setup in the SRAM memory.
17	DGPS	1.WAAS, EGNOS
Interface		
18	LNA	25dB Gain. (Typical)
19	I/O Pin	6pin
Mechanical requirements		
20	Weight	8 g Typ.
Power consumption		
21	Vcc	DC +3.3 V±5%
22	Current	GPS : Avg Acquisition <50mA@3.3V without ext.Antenna Avg Tracking <48mA@3.3V without ext.Antenna
Environment		

格式化: 英文 (美國)

23	Operating temperature	-25 ~ 85°C
24	Storage temperature	-40 ~ 85°C
25	Humidity	≤ 95%

MMCX edge mount Jack Receptacle specification (External Antenna)

Impedance	50ohm
Frequency range	0~6GHz
V.S.W.R	1.2max
Working voltage	175Vrms max
Durability	500 mating
External Antenna spec.	
DC supply	2.85V±2%
DC current	20mA max.
Input return Loss	≤ -10dB
Output return Loss	≤ -10dB
Gain	25 dB typical

1.5 Application Circuit

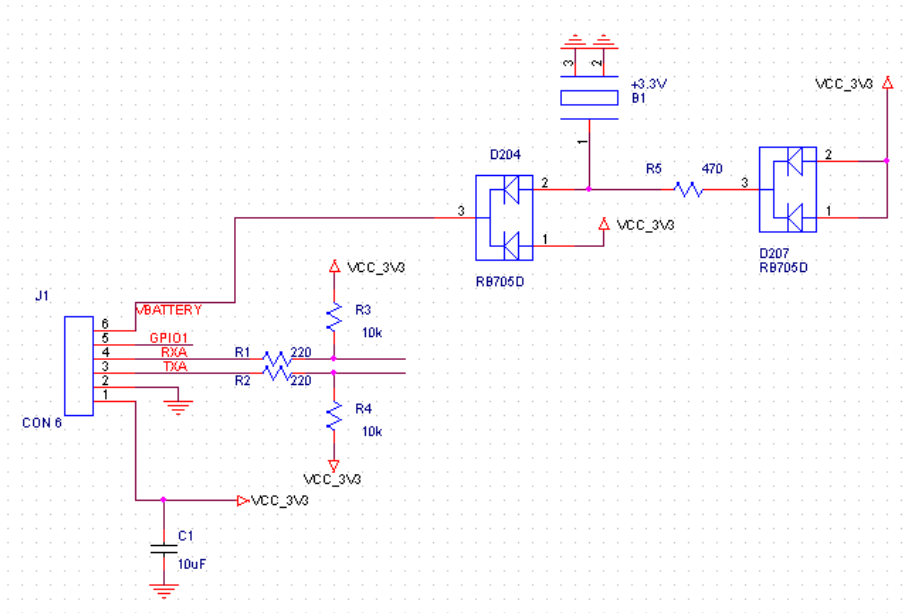

Figure 1-4 Application Circuit Reference

Note:

- (1) Ground Planes:
This pin2 should be connect to ground.
- (2) Serial Interface:
 - (I) The TXA pin is recommended to connect to serial resistance(220Ω) and pull up ($10K\Omega$). It can increase the stability of serial data. (Default NMEA)
 - (II) The RXA pin is recommended to connect to serial resistance(220Ω) and pull up ($10K\Omega$). It can increase the stability of serial data. (Default NMEA)
- (3) Backup Battery:
When module is working, must to supply VCC pin(Pin1) and VBATT pin(Pin6) power at the same time.
It's recommended to connect a backup battery to VBATT pin.
In order to enable the warm start and hot start features of the GPS receiver.
If you use backup battery, should be add a bypassing capacitor ($10\mu\text{F}$) at VBATT pin. It can reduce noise and increase the stability.

(4) Power:

Connect VCC pin to DC 3.3V. The power supply must add bypass capacitor(10uF and 1uF).It can reduce the Noise from power supply and increase power stability.

(5) GPIO:

The GPIOs function are for customer used.

If no use GPIO function, it don't connect anything.

1.6 Mechanical Layout

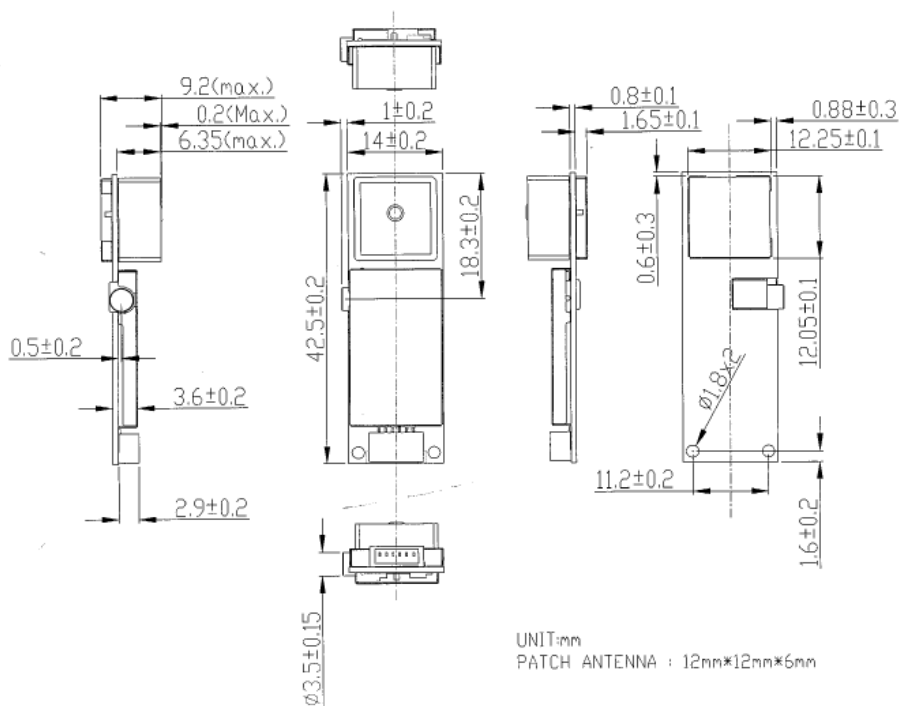

Figure 1-5 Mechanical Layout

1.7 Hardware interface

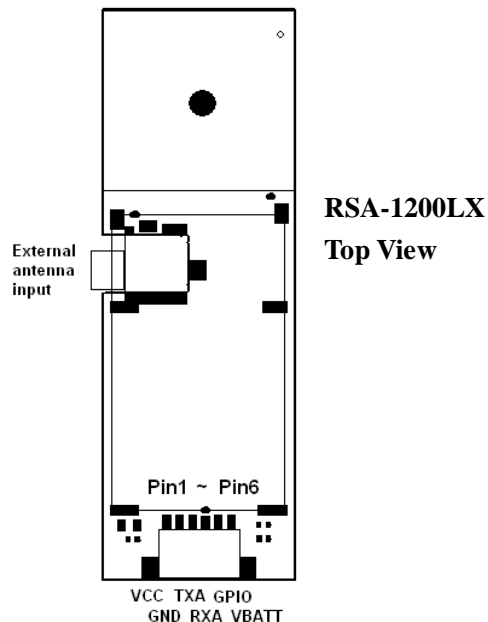

Figure 1-6 Hardware Interface

Table 1-2 Definition of Pin assignment

Pin Defined

Pin	Signal Name	I/O	Description	Characteristics
1	VCC	I	DC Supply Voltage input	DC +3.3V±5%
2	GND	G	Ground	Reference Ground
3	TXA	O	Serial port A	$2.85V \geq V_{OH} \geq 2.38V$ $V_{OL} \leq 0.7V$
4	RXA	I	Serial port A	$3.15V \geq V_{IH} \geq 2.0V$ $-0.3V \leq V_{IL} \leq 0.86V$
5	GPIO-1	I/O	General purpose I/O	$3.15V \geq V_{IH} \geq 2.0V$ $-0.3V \leq V_{IL} \leq 0.86V$ $2.85V \geq V_{OH} \geq 2.14V$ $V_{OL} \leq 0.71V$
6	VBATT	I	Backup voltage supply	DC + 2.5 ~ +3.6V Current ≤ 10uA

Definition of Pin assignment

VCC(+3.3V DC power Input)

This is the DC power supply input pin for GPS system. It provides voltage to module.

GND

GND provides the reference ground.

TXA

This is the main transmitting channel and is used to output navigation and measurement data to SiRFdemo or user written software

RXA

This is the main receiver channel and is used to receive software commands to the board from SiRFdemo software or from user written software.

VBATT (Backup battery)

When module is working, must to supply VCC pin(Pin1) and VBATT pin(Pin6) power at the same time.

This is the battery backup input that powers the SRAM and RTC when main power is removed. Typical current draw is 10uA.

The supply voltage should be between 2.5V and 3.6V.

GPIO Functions

- 2 Several I/Os are connected to the digital interface connector for custom applications.**

Software Interface

2.1 NMEA V3.0 Protocol

Its output signal level is TTL: 4800 bps (default), 8 bit data, 1 stop bit and no parity. It supports the following NMEA-0183

Messages: GGA, GLL, GSA, GSV, RMC and VTG.

NMEA Output Messages: the Engine board outputs the following messages as shown in Table 2-1:

Table 2-1 NMEA-0183 Output Messages

NMEA Record	Description
GGA	Global positioning system fixed data
GLL	Geographic position – latitude / longitude
GSA	GNSS DOP and active satellites
GSV	GNSS satellites in view
RMC	Recommended minimum specific GNSS data
VTG	Course over ground and ground speed

格式化: 法文 (法國)

2.1.1 GGA-Global Positioning System Fixed Data

Table 2-2 contains the values of the following example:

\$GPGGA, 161229.487, 3723.2475, N, 12158.3416, W, 1, 07, 1.0, 9.0, M, , , , 0000*18

Table 2-2 GGA Data Format

Name	Example	Units	Description
Message ID	\$GPGGA		GGA protocol header
UTC Position	161229.487		hhmmss.sss
Latitude	3723.2475		ddmm.mmmm
N/S Indicator	N		N=north or S=south
Longitude	12158.3416		Dddmm.mmmm
E/W Indicator	W		E=east or W=west
Position Fix Indicator	1		See Table 2-1
Satellites Used	07		Range 0 to 12
HDOP	1.0		Horizontal Dilution of Precision
MSL Altitude	9.0	meters	
Units	M	meters	

Geoid Separation		meters	
Units	M	meters	
Age of Diff. Corr.		second	Null fields when DGPS is not used
Diff. Ref. Station ID	0000		
Checksum	*18		
<CR> <LF>			End of message termination

Table 2-3 Position Fix Indicators

Value	Description
0	Fix not available or invalid
1	GPS SPS Mode, fix valid
2	Differential GPS, SPS Mode, fix valid
3-5	Not Supported GPS PPS Mode, fix valid
6	Dead Reckoning Mode, fix valid

格式化: 法文 (法國)

2.1.2 GLL-Geographic Position –Latitude/Longitude

Table 2-4 contains the values of the following

Example: \$GPGLL, 3723.2475, N, 12158.3416, W, 161229.487, A*2C

Table 2-4 GLL Data Format

Name	Example	Units	Description
Message ID	\$GPGLL		GLL protocol header
Latitude	3723.2475		ddmm.mmmm
N/S Indicator	N		N=north or S=south
Longitude	12158.3416		Dddmm.mmmm
E/W Indicator	W		E=east or W=west
UTC Position	161229.487		hhmmss.ss
Status	A		A=data valid or V=data not valid
Mode	A		A=Autonomous, D=DGPS, E=DR
Checksum	*2C		
<CR> <LF>			End of message termination

格式化: 法文 (法國)

2.1.3 GSA-GNSS DOP and Active Satellites

Table 2-5 contains the values of the following example:

\$GPGSA, A, 3, 07, 02, 26, 27, 09, 04, 15, , , , , 1.8, 1.0, 1.5*33

Table 2-5 GSA Data Format

Name	Example	Units	Description
Message ID	\$GPGSA		GSA protocol header
Mode 1	A		See Table 4-2
Mode 2	3		See Table 4-1
Satellite Used	07		Sv on Channel 1
Satellite Used	02		Sv on Channel 2
....		
Satellite Used			Sv on Channel 12
PDOP	1.8		Position Dilution of Precision
HDOP	1.0		Horizontal Dilution of Precision
VDOP	1.5		Vertical Dilution of Precision
Checksum	*33		
<CR><LF>			End of message termination

Table 2-6 Mode 1

Value	Description
1	Fix not available
2	2D
3	3D

Table 2-7 Mode 2

Value	Description
M	Manual-forced to operate in 2D or 3D mode
A	Automatic-allowed to automatically switch 2D/3D

2.1.4 GSV-GNSS Satellites in View

Table 2-8 contains the values of the following example:

\$GPGSV, 2, 1, 07, 07, 79, 048, 42, 02, 51, 062, 43, 26, 36, 256, 42, 27, 27, 138,
42*71\$GPGSV, 2, 2, 07, 09, 23, 313, 42, 04, 19, 159, 41, 15, 12, 041, 42*41

Table 2-8 GSV Data Format

Name	Example	Units	Description
Message ID	\$GPGSV		GSV protocol header
Number of Messages ¹	2		Range 1 to 3
Messages Number ¹	1		Range 1 to 3
Satellites in View	07		
Satellite ID	07		Channel 1(Range 1 to 32)
Elevation	79	degrees	Channel 1(Maximum 90)
Azimuth	048	degrees	Channel 1(True, Range 0 to 359)
SNR (C/No)	42	dBHz	Range 0 to 99, null when not tracking
....		
Satellite ID	27		Channel 4(Range 1 to 32)
Elevation	27	degrees	Channel 4(Maximum 90)
Azimuth	138	degrees	Channel 4(True, Range 0 to 359)
SNR (C/No)	42	dBHz	Range 0 to 99, null when not tracking
Checksum	*71		
<CR> <LF>			End of message termination

¹Depending on the number of satellites tracked multiple messages of GSV data may be required.

2.1.5 RMC-Recommended Minimum Specific GNSS Data

Table 2-9 contains the values of the following example:

\$GPRMC, 161229.487, A, 3723.2475, N, 12158.3416, W, 0.13, 309.62, 120598, , *10

Table 2-9 RMC Data Format

Name	Example	Units	Description
Message ID	\$GPRMC		RMC protocol header
UTC Position	161229.487		hhmmss.sss
Status	A		A=data valid or V=data not valid
Latitude	3723.2475		ddmm.mmmm
N/S Indicator	N		N=north or S=south
Longitude	12158.3416		dddmm.mmmm
E/W Indicator	W		E=east or W=west
Speed Over Ground	0.13	knots	

Course Over Ground	309.62	degrees	True
Date	120598		ddmmyy
Magnetic Variation		degrees	E=east or W=west
Mode	A		A=Autonomous, D=DGPS, E=DR
Checksum	*10		

格式化: 法文 (法國)

2.1.6 VTG-Course Over Ground and Ground Speed

Table 2-10 contains the values of the following example:

\$GPVTG, 309.62, T, , M, 0.13, N, 0.2, K*6E

Table 2-10 VTG Data Format

Name	Example	Units	Description
Message ID	\$GPVTG		VTG protocol header
Course	309.62	degrees	Measured heading
Reference	T		True
Course		degrees	Measured heading
Reference	M		Magnetic
Speed	0.13	knots	Measured horizontal speed
Units	N		Knots
Speed	0.2	km/hr	Measured horizontal speed
Units	K		Kilometer per hour
Mode	A		A=Autonomous, D=DGPS, E=DR
Checksum	*6E		
<CR><LF>			End of message termination

格式化: 法文 (法國)

3 Package

3.1 Package Specification

Shipment Method: PE Bag

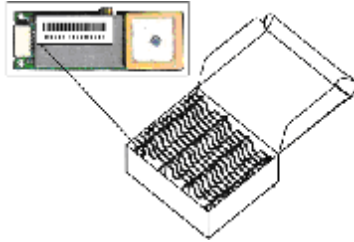

Figure 3-1 Package Specifications

4 Contact Information Section

Contact: sales@royaltek.com

Headquarter:

4F, 188, Wen Hwa 2nd Rd., Kuei Shan.

Tao Yuan 33377, Taiwan

TEL: 886-3-3960001

FAX: 886-3-3960065

Web Site: <http://www.royaltek.com>

Web Site Customer Service: <http://www.royaltek.com/contact>

格式化: 德文 (德國)

5 Revision History

Title	RSA-1200LX GPS Module		
Doc Type	User Manual		
Revision Number	Date	Author	Change notice
1.0	2008/04/25	Linda Fan	Initial Release

Copyright © 2006-2007, RoyalTek Company Ltd.