

# PART #MSP-DUK9000

## Universal Ceiling Projector Mount Kit

The Universal Ceiling Projector Mount provides a unique, simplified method of ceiling mounting your inverted projector. This low profile design offers three easy mounting methods (adjustable column, flush or threaded rod); roll, pitch and yaw adjustment; a cable management system; and a universal bracket that allows quick projector disconnect without loss of registration.

The Universal Ceiling Projector Mount is constructed of heavy gauge steel and designed to ensure proper projector ventilation.

Fast and precise image registration is achieved through the easy roll, pitch and yaw adjustments built into the Universal Ceiling Projector Mount.

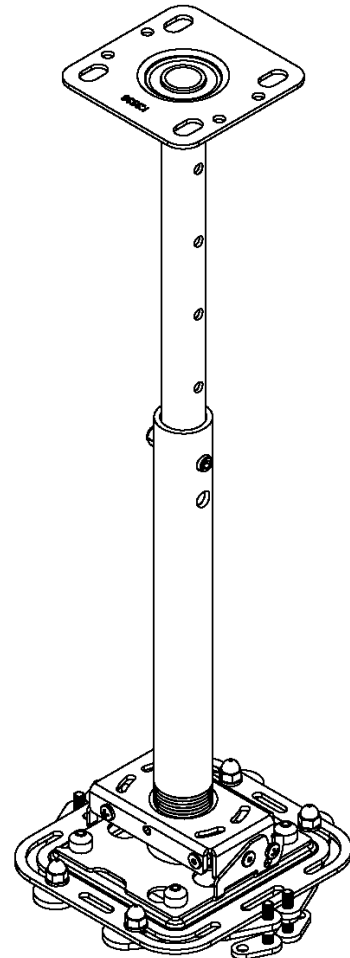

### BEFORE YOU BEGIN

- **CAUTION:** To prevent damage to the Universal Ceiling Mount, which could affect or void the Factory warranty, thoroughly study all instructions and illustrations before you begin to install the Universal Ceiling Mount. Pay particular attention to the “Important Precautions” on Page 1.



CHIEF MANUFACTURING INC.

1-800-582-6480 952-894-6280 FAX 952-894-6918 EUROPE 49 7031/76 91 41  
8401 EAGLE CREEK PARKWAY chiefeurope@chiefmfg.com  
SAVAGE, MINNESOTA 55378 USA

8832-000048 Rev. A00  
©2004 Chief Manufacturing  
[www.chiefmfg.com](http://www.chiefmfg.com)  
Printed in USA 09/04



## IMPORTANT WARNINGS AND CAUTIONS!

**WARNING:** A **WARNING** alerts you to the possibility of serious injury or death if you do not follow the instructions.

**CAUTION:** A **CAUTION** alerts you to the possibility of damage or destruction of equipment if you do not follow the corresponding instructions.

- **WARNING: Improper installation can result in serious personal injury! Make sure that the ceiling structural members can support a redundant weight factor *five times the total weight of the equipment*. If the ceiling can not support this weight, reinforce the ceiling before installing the Universal Ceiling Projector Mount.**
- **CAUTION:** Inspect the unit for shipping damage. See “PARTS & DIMENSIONS” on page 2

## TOOLS REQUIRED FOR INSTALLATION

- Wire Cutter
- Socket Set
- Wrenches
- Scissors
- Allen Wrench (provided)
- Phillips screwdrivers, No. 1 and No. 2

**NOTE:** Other tools may be required depending on the method of installation.

## CONTENTS

PARTS & DIMENSIONS .....	2
INSPECT THE UNIT BEFORE	
INSTALLING .....	4
PREPARE THE CEILING .....	4
General Guidelines .....	4
UNIVERSAL CEILING PROJECTOR MOUNT	
INSTALLATION PROCEDURES .....	5
Adjustable Column .....	5
Standard Fasteners Secured to	
a Wood Framing Member .....	6
Threaded Rod .....	6
PROJECTOR INTERFACE PLATE	
ATTACHMENT PROCEDURES .....	7
PROJECTOR INTERFACE PLATE	
INSTALLATION PROCEDURES .....	8
CABLE MANAGEMENT PROCEDURES .....	8
SECURITY INSTALLATION (Optional) .....	9
PROJECTOR ALIGNMENT	
INSTRUCTIONS .....	10
Pitch/Roll/Yaw .....	10

## PARTS &amp; DIMENSIONS

Table 1:

ITEM	Nomenclature	Qty	ITEM	Nomenclature	Qty
10	Ceiling Column	1	160	Cable Tie	4
20	1/4"-20 Locking Nut	1	170	Cable Wrap	1
30	1/4"-20 x 1 1/2" Security Bolt	1	180	M3 X 12mm Button Head Security Screw	4
40	1" NPT Column	1	190	M4 X 12mm Button Head Security Screw	4
50	Universal Projector Mount	1	200	M5 X 12mm Button Head Security Screw	4
60	Thumb Nut	4	210	M6 X 12mm Button Head Security Screw	4
70	M3 X 12mm Phillips Pan Head Screw	4	220	1/4"-20 x .625" Button Head Security Screw	4
80	M3 Flat Washer (Standard)	4	230	1/4"-20 NyLock Locknut	2
90	Universal Mini SLB Assembly	1	240	M4 X 12mm Phillips Pan Head Screw	4
100	3/16" Security Hex Key	1	250	M5 X 12mm Phillips Pan Head Screw	4
110	5/32" Security Hex Key	1	260	M6 X 12mm Phillips Pan Head Screw	4
120	3/32" Security Hex Key	1	270	M4 Flat Washer (Standard)	4
130	5/32" Security Hex Key (Standard)	1	280	M5 Flat Washer (Standard)	4
140	5/16-18 X .50" Security Set Screw	1	290	M6 Flat Washer (Standard)	4
150	#10-24 X .25" Security Flat Head Screw	1			

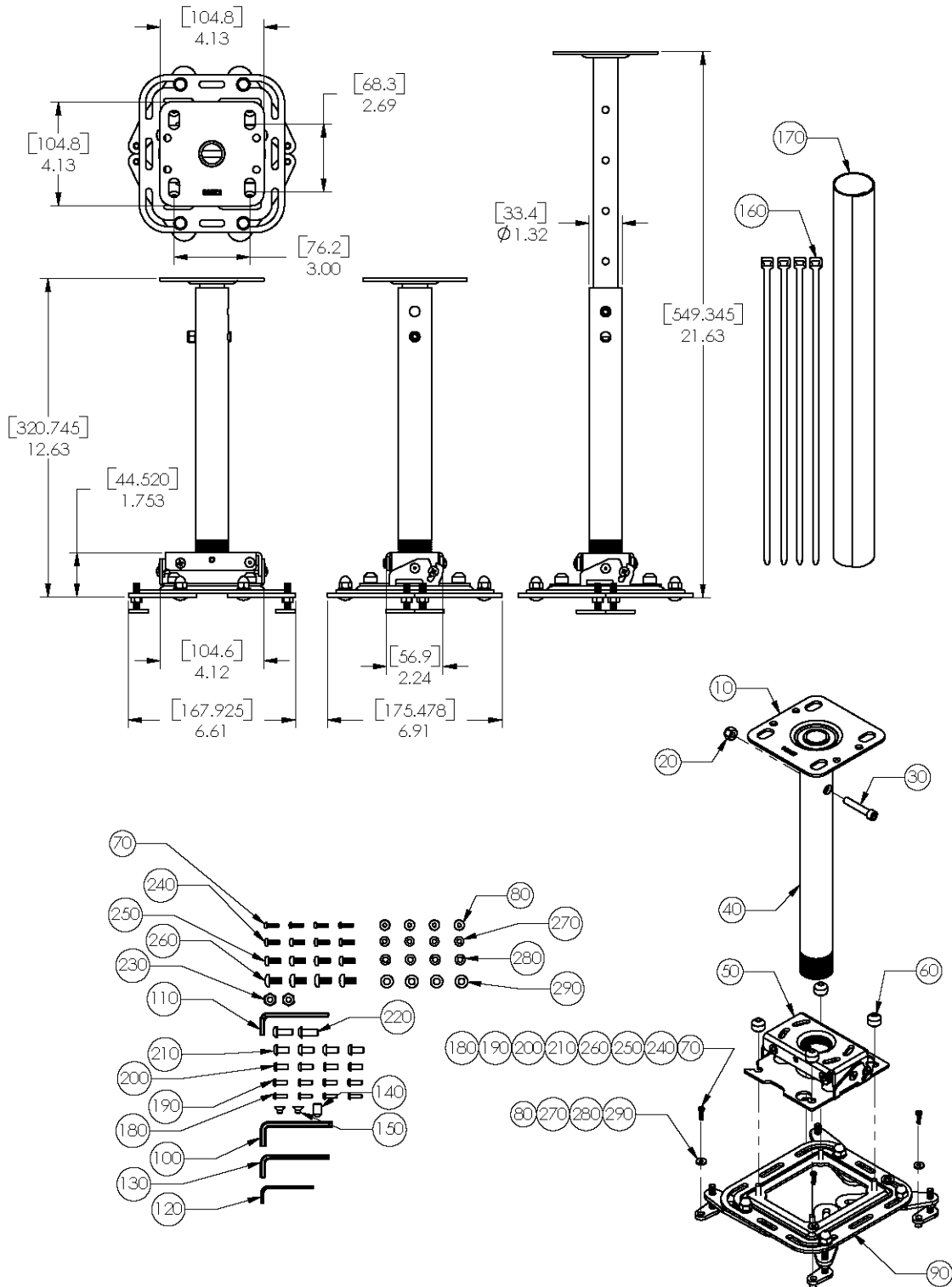

## INSPECT THE UNIT BEFORE INSTALLING

1. Carefully inspect the Universal Ceiling Projector Mount for shipping damage. If any damage is apparent, call your carrier claims agent and do not continue with the installation until the carrier has reviewed the damage.

**NOTE:** Read all instructions before starting installation.

2. Lay out components to ensure you have all the required parts before proceeding (see “PARTS & DIMENSIONS” on page 2).

## PREPARE THE CEILING

Because of the wide variety of possible mounting situations, Dukane Corporation can only provide general guidelines for installation. Study the following information carefully, and adapt it as necessary to fit your specific installation.

**WARNING: Be especially aware of the weight of the equipment, and the potential for personal injury or of damage to the equipment if it is not adequately mounted.**

The “General Guidelines” below and the information on the following pages cover the most common mounting situations:

- Suspended from an adjustable column secured to a structural cross brace in the ceiling.
- Standard fasteners secured to a wood framing member.
- Suspended from threaded rods that are secured to the structural cross brace

### General Guidelines

- Carefully determine the position of the Universal Ceiling Projector Mount, and its distance from the screen. This will require knowing the lens to screen distance (see projector specifications for set-up).

**WARNING: Improper installation can result in serious personal injury! To avoid such injury, make sure that the ceiling structural members can support a redundant weight factor *five times* the total weight of the equipment you intend to support overhead. If they cannot, the ceiling must be reinforced before you install the Universal Ceiling Projector Mount.**

# UNIVERSAL CEILING PROJECTOR MOUNT INSTALLATION PROCEDURES

There are three common methods for installing the Universal Ceiling Projector Mount Series ceiling mount. The Universal Ceiling Projector Mount can be suspended from an adjustable column, standard fasteners secured to a wood framing member, or threaded rods.

**WARNING: Improper installation can cause serious personal injury! Make sure that the ceiling structural members can support a redundant weight factor *five times* the total weight of the equipment you intend to support overhead. The ceiling must be reinforced before you install the Universal Ceiling Projector Mount if the ceiling cannot support a redundant weight factor *five times* the total weight of the equipment.**

## Adjustable Column

Installation using an adjustable column, or 1" diameter schedule 40 steel pipe section with 1" NPT threads, requires securing the adjustable column or pipe to the building structure. We suggest the use of a backing block or Unistrut to secure the adjustable column or pipe to a structural member (see Figure 2). Install the Universal Ceiling Projector Mount on the adjustable column or pipe as follows:

1. Thread the Universal Ceiling Projector Mount onto the pipe a minimum of 1/2" to allow for final yaw adjustment.
2. Using Allen wrench provided, tighten the set screw to lock the Universal Ceiling Projector Mount in position (see Figure 3).
3. Proceed to "PROJECTOR INTERFACE PLATE ATTACHMENT PROCEDURES" on page 7.

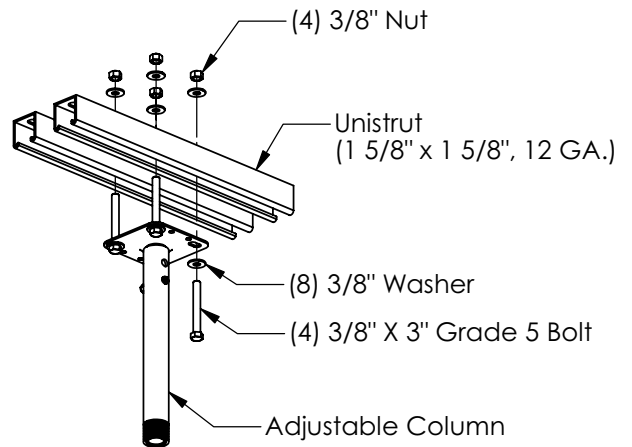
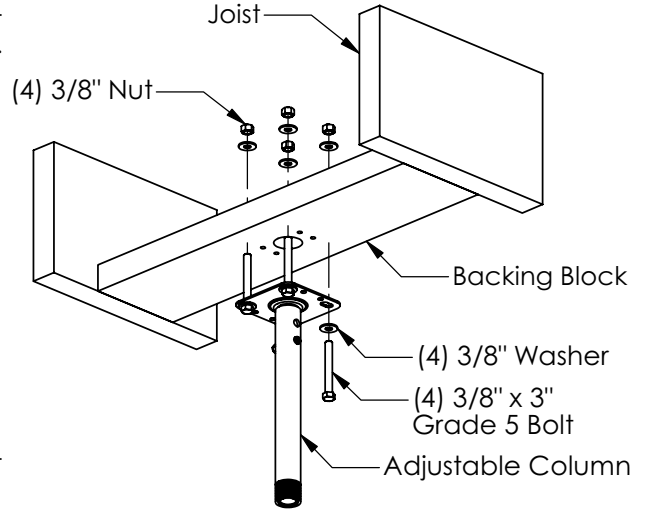

Figure 2. Examples Using Adjustable Column

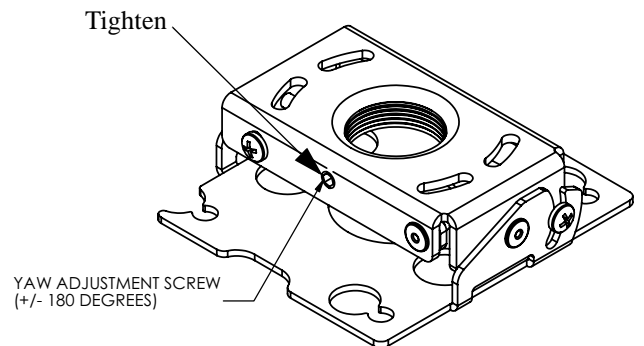
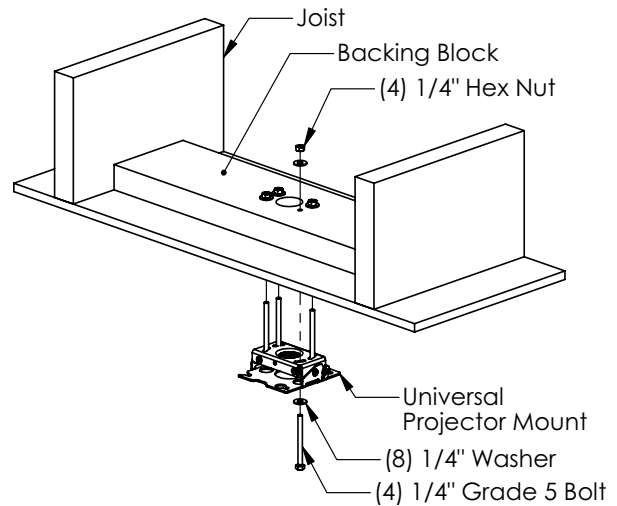

Figure 3. Tighten Set Screw

## Standard Fasteners Secured to a Wood Framing Member

The Universal Ceiling Projector Mount can be secured to a wood framing member through four slotted holes in the Universal Ceiling Projector Mount using four 1/4" diameter lag screws or, if the area is accessible from above, four 1/4" diameter machine bolts, nuts, and washers. Install the Universal Ceiling Projector Mount as follows:

1. Secure the Universal Ceiling Projector Mount to the wood framing member.
2. Proceed to "PROJECTOR INTERFACE PLATE ATTACHMENT PROCEDURES" on page 7.



## Threaded Rod

Using four 1/4" diameter threaded rods, the Universal Ceiling Projector Mount can be secured to a typical unistrut, angle or channel assembly at the overhead structural members (trusses or I-beams) (see Figure 4). Install the Universal Ceiling Projector Mount as follows:

1. Secure one end of the threaded rod to the structural member.
2. Install a 1/4-20 hex nut on each threaded rod.
3. Install the Universal Ceiling Projector Mount on the threaded rod.

**NOTE:** Holes in the Universal Ceiling Projector Mount allow socket wrench access without unit disassembly.

4. Secure the Universal Ceiling Projector Mount to the threaded rod using eight 1/4-20 hex nuts.

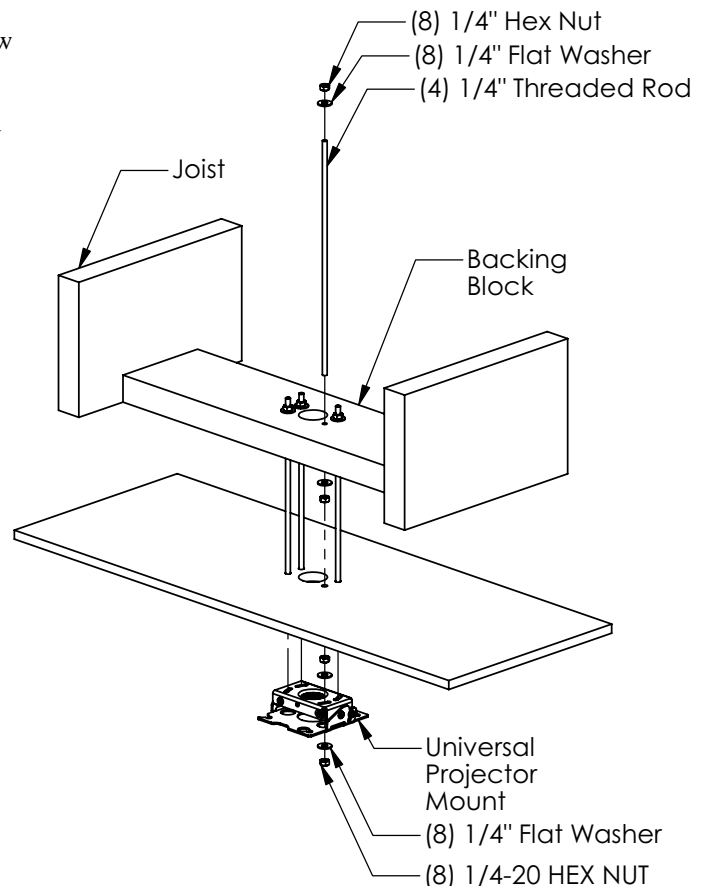

Figure 4. 1/4" Threaded Rod

## PROJECTOR INTERFACE PLATE ATTACHMENT PROCEDURES

Attach the bottom portion of the universal projector mount to the projector as follows.

1. Loosen, but do not remove, acorn nuts securing arms of the universal projector mount (see Figure 5).
2. Adjust front and back legs to mounting points. If there are only three mounting points, remove one leg from the mount.
3. Adjust feet (rotate right to raise, left to lower), making sure to allow for proper air ventilation and the mount is level with the projector [some feet may need to be at different heights to keep the mount level (M3, M4, M5 and M6 screws and washers included)].
4. If the mounting holes are closer than a five inch diameter, raise the feet all the way up so they will swing under the universal interface bracket.

**WARNING:** You must use proper attaching hardware and installation procedures. Failure to use proper attaching hardware and installation procedures may result in equipment damage or serious personal injury.

5. Determine proper screw size and depth (M3, M4, M5 and M6 included) for projector mounting and correct washers (M3, M4, M5 and M6 included). If proper screw size is not included with this unit, you must purchase the proper attaching hardware separately.
6. Secure (loosely) back two legs of universal projector mount to the projector at mounting locations.
7. Secure (loosely) front two legs of universal projector mount to the projector at mounting locations.
8. Move the universal projector mount to the center of gravity of the projector.
9. Make sure the threaded studs on the plate are square in relation to the front of the projector.
10. Tighten screws and acorn nuts securing the legs of the universal projector mount.
11. Tighten hex nuts on the threaded studs to secure inserts at proper positions.

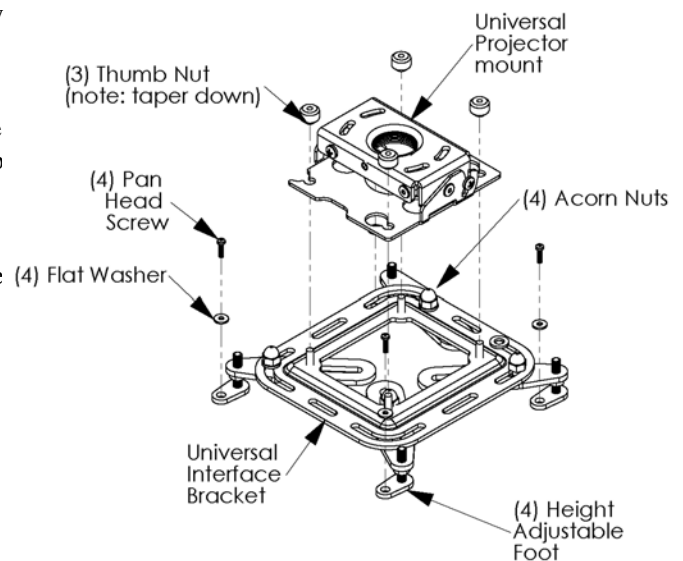

Figure 5. Projector Interface Plate to Universal Ceiling Projector Mount Attachment

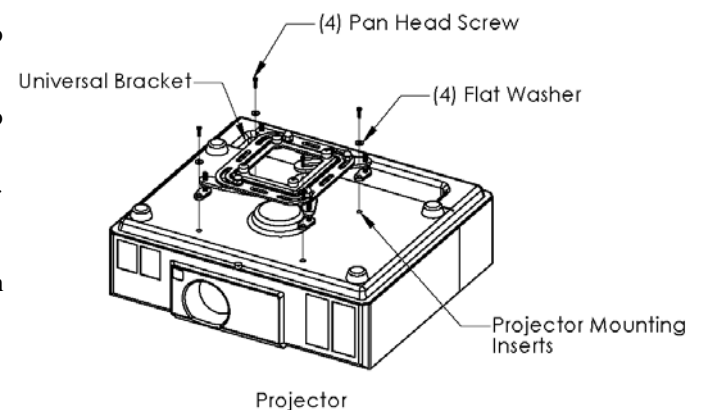

Figure 6. Install the Projector Interface Plate on Your Projector



## PROJECTOR INTERFACE PLATE INSTALLATION PROCEDURES

The bracket attaches to the universal projector mount lifting and sliding the screws of the bracket into the slot and four vee slots of the universal projector mount (see Figure 5). Secure the bracket using provided thumb screws and route cabling as necessary. Install the universal projector mount on the bracket as follows:

**NOTE:** It is not necessary to remove the thumb nuts from the studs to install and remove the projector.

1. Install, loosely, the 10-24 thumb nuts on the 10-24 studs of the universal projector mount.
2. Align the four locating slots of the universal projector mount with the 10-24 studs of the bracket and slide the bracket on the universal projector mount to the limit of the slotted holes.

**NOTE:** The tapers of the thumb nuts should seat in the holes of the bracket.

3. Secure the Bracket to the universal projector mount using the thumb nuts (tapered side down).
4. Route cables as necessary.

## CABLE MANAGEMENT PROCEDURES

1. Route cables as necessary.
2. Secure cables using cable ties (see Figure 7).
3. Cut and install cable wrap.

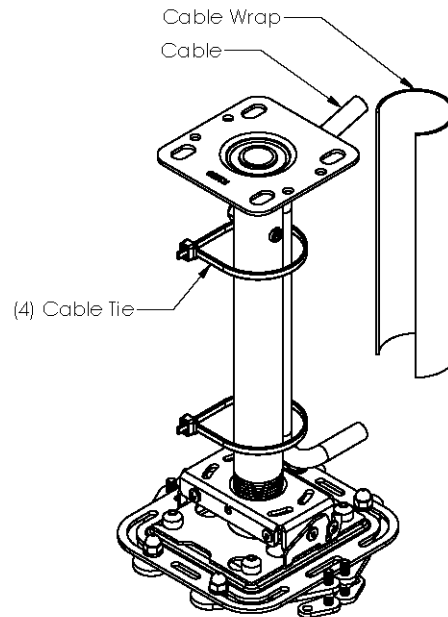

Figure 7. Cable Routing Example

## SECURITY INSTALLATION (OPTIONAL)

1. Using security wrench (provided), remove 5/16" standard set-screw and replace using 5/16" security screw (see Figure 8).
2. Remove two screws from bottom of Projector Interface Plate, preferably one from each corner.
3. Using security wrench and security screws from All-Points Security package, secure Projector Interface Plate to projector.
4. Using security wrench (provided), replace screws in Projector Interface Plate with undercut security screws from top from top plate.
5. Remove two 1/4-20 x .5" round head carriage bolts and 1/4-20 acorn nut caps and replace using two security screws and lock nut Nylocks (see Figure 8).

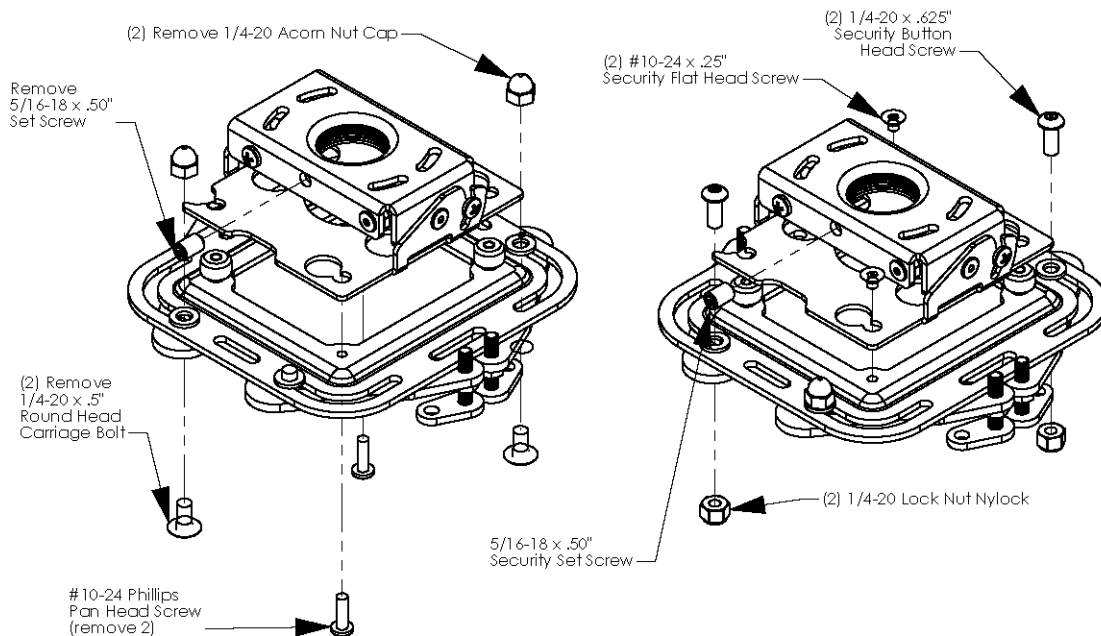

Figure 8. Adding Optional Security

## PROJECTOR ALIGNMENT INSTRUCTIONS

The Universal Ceiling Projector Mount can be adjusted for vertical elevation (pitch), horizontal tilt (roll), and rotation (yaw). Once the desired position is located and all the screws of the Universal Ceiling Projector Mount are tightened, the projector may be removed from its location and replaced using the four thumb nuts without losing the registration of the projector. Align the projector as follows:

### Pitch

Adjust pitch using the pitch adjustment screw located on each end of the Universal Ceiling Projector Mount. Adjust pitch as follows:

1. Loosen the pitch adjustment screw on each side of the Universal Ceiling Projector Mount (see Figure 9).
2. Adjust projector angle to desired pitch.
3. Tighten the two pitch adjustment screws.

### Roll

Adjust roll using two roll adjustment screws on the face and back of the Universal Ceiling Projector Mount. Adjust roll as follows:

1. Loosen the roll adjustment screw on the face and back opposite the pitch clamp (see Figure 9).
2. Adjust projector to desired roll position.
3. Tighten the roll adjustment screw.

### Yaw

Adjust yaw by threading or unthreading the Universal Ceiling Projector Mount on the 1" pipe. Adjust yaw as follows:

1. Loosen the set screw (see Figure 9).

**WARNING: Do not turn the Universal Ceiling Projector Mount to the end of the pipe threads. The Universal Ceiling Projector Mount, Projector Interface Plate, and projector will fall from the pipe if the Universal Ceiling Projector Mount is unthreaded too far.**

2. Adjust projector by turning the Universal Ceiling Projector Mount on the 1" pipe to the desired yaw position.

**NOTE:** Overtightening the set screw may damage threads and make adjusting yaw difficult. Make sure yaw adjustment is set before tightening set screw.

3. Tighten the set screw.

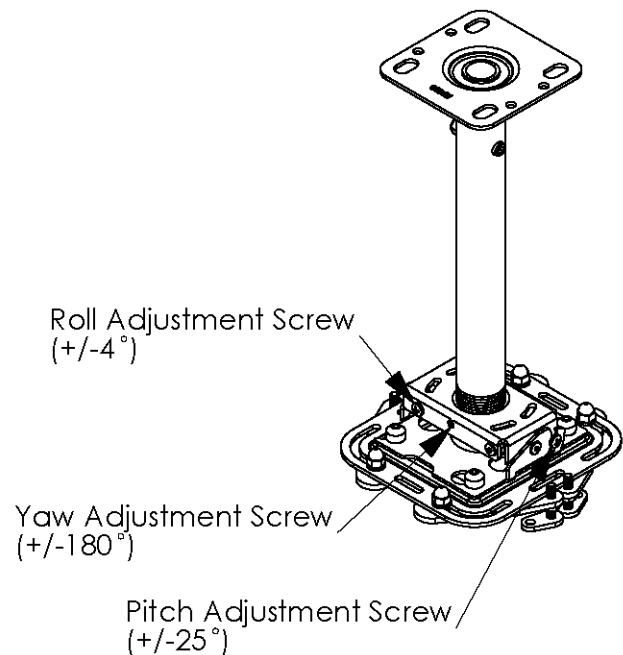

Figure 9. Pitch, Roll, and Yaw Adjustment