

# Honeywell

## DH90 Whole House Dehumidifier with fresh air ventilation

### Installation Guide

**Dehumidification**  
**Fresh Air Ventilation**  
**Compact Size**  
**Energy Efficient**



The DH90 whole house dehumidifier integrates high-capacity dehumidification, fresh air ventilation, and filtration, into a compact and easy to install enclosure.

An automatic ventilation controller and dehumidistat are included.

The dehumidifier removes 90 pints of water from the air per day (80F, 60% RH) while only using 6.2 Amps of electricity.

The high moisture removal capacity helps maintain proper levels of humidity in most homes.

#### Dehumidification

The DH90's high efficiency refrigeration system is further enhanced with a heat exchanger to achieve exceptional performance while keeping your energy costs as low as possible.

#### Fresh Air Ventilation (optional)

Fresh air may be ducted to the unit and regulated using the provided Honeywell W8150 fresh air ventilation controller along with the optional EARD6 damper.

**HVAC Installer: Please leave manual for homeowner.**



## Table of Contents

Introduction . . . . .	1	4.5 Noise Abatement . . . . .	7
Features & Benefits . . . . .	1	<b>5. Maintenance . . . . .</b>	<b>7</b>
Safety Precautions . . . . .	2	5.1 Air Filter . . . . .	7
<b>1. Intended Application . . . . .</b>	<b>3</b>	5.2 Optional Fresh Air Intake . . . . .	7
<b>2. Approvals . . . . .</b>	<b>3</b>	<b>6. Wiring Diagrams . . . . .</b>	<b>7</b>
<b>3. Specifications . . . . .</b>	<b>3</b>	6.1 Choose correct wiring diagram . . . . .	8
<b>4. Installation . . . . .</b>	<b>3</b>	<b>7. Parts List . . . . .</b>	<b>9</b>
4.1 Installation Checklist . . . . .	3	<b>8. Setting the Control . . . . .</b>	<b>9</b>
4.1A Power Accessibility . . . . .	3	<b>9. Service . . . . .</b>	<b>10</b>
4.1B Accessibility . . . . .	3	9.1 Troubleshooting . . . . .	10
4.1C Support Structure and Suspension . . . . .	3	9.2 Refrigerant Charging . . . . .	11
4.1D Sizing Chart . . . . .	3	9.3 Compressor/Capacitor Replacement . . . . .	11
<b>4.2 Electrical Requirements . . . . .</b>	<b>3</b>		
<b>4.3 Condensate Removal . . . . .</b>	<b>4</b>		
<b>4.4 Ducting . . . . .</b>	<b>4</b>		
4.4A Fresh Air / Supply Air . . . . .	4		
4.4B Ducting for Fresh Air—Option . . . . .	5		
4.4C Installation in a Basement or Crawl Space with an Existing Forced Air HVAC System . . . . .	5		
4.4D Installation in an Attic with an Existing Forced Air HVAC System . . . . .	6		
4.4E Installation in a Structure with Two Forced Air HVAC Systems . . . . .	6		

## Safety Precautions

Read the installation, operation and maintenance instructions carefully before installing and operating this device. Proper adherence to these instructions is essential to obtain maximum benefit from your DH90 indoor air quality system.

### READ AND SAVE THESE INSTRUCTIONS

- The device is designed to be installed INDOORS IN A SPACE THAT IS PROTECTED FROM RAIN AND FLOODING.
- Install the unit with space to access the front panel for maintenance and service.
- Avoid directing the discharge air at people, or over the water in pool areas.
- If used near a pool or spa; be certain there is NO chance the unit could fall into the water, splashed and that it is plugged into a GFI GROUND FAULT INTERRUPT OUTLET.
- DO NOT place the device directly on structural members.
- A drain pan MUST be placed under the unit if installed above a living area or above an area where water leakage could cause damage.

## 1. Intended Application for DH90

The DH90 is intended for use in residential applications to reduce the indoor humidity levels and increase comfort. With the optional ventilation ducting and ventilation control hookup, the device also provides precise amounts of ventilation air.

## 2. Approvals

The DH90 is certified by ETL to meet UL 474 and CSA 22.2 No. 92.

## 3. Specifications

Model:	DH90
Electrical:	110-120 VAC, 6.2 Amps, 60 Hz, grounded
Capacity:	90 pints/day @ 80°F, 60% RH
Inlet air temperature range:	55°F min., 100°F max.
Air Flow:	200 CFM without external ducting
Refrigerant Charge:	1 lb., 12 oz. R22
Duct Connections:	Round 10" inlet, 10" outlet, 6" ventilation inlet
Filter Size:	Pleated MERV 11: 14" x 14" x 1"
Unit Size (w/o Duct Collars):	34.5"L x 15.75"W x 20.875"H
Unit Weight:	92 lbs
Shipping Weight:	99 lbs

## 4. Installation

### 4.1 Installation Checklist



**IMPORTANT:** Prior to installation of the DH90, the following checklist should be reviewed.

The DH90 can be installed in a variety of locations to meet the owner's needs, and integrate with existing forced air systems or existing ductwork if desired. Choose a location with consideration to accessibility for service, drain availability, and power outlet location.

### 4.1A Power Accessibility

Unit should be located in an area where the cord's length (10') should easily reach a 115 VAC electrical outlet with a minimum of a 15 A circuit capacity.

### 4.1B Accessibility

The installed DH90 should have at least 14 inches of clearance in the front of the device to service the filter.

### 4.1C Support Structure and Suspension

Place the DH90 on supports to raise the base of the unit. Do not place the DH90 directly on structural building members without vibration absorbers or unwanted noise may result.

The DH90 may be suspended from structural members by supporting the entire base of the unit via cross members, rigid frame, or the like. **Do not hang the a DH90 from the cabinet.** Remember to place a drain pan under the unit if it is suspended above a finished area or above an area where water leakage could cause damage.

### 4.1D Sizing Chart

\*This sizing chart is based on extreme climates where Rh levels are between 70 and 90% outdoor Rh. For less extreme climates then larger homes can be adequately served. Actual requirements may vary.

Home Size (square feet)	Dehumidifier Capacity Required to Maintain Desired Indoor Rh*		
	60% Indoor Rh	55% Indoor Rh	50% Indoor Rh
	Pints/day	Pints/day	Pints/day
2080	49-54	55-58	71-78
2600	61-68	65-72	90-97
3120	75-82	79-86	95-110

### 4.2 Electrical Requirements



**WARNING:** Installation must be performed by a qualified service technician and must comply with local codes. Remove power to the device before installing or servicing the device. Failure to connect the device according to these instructions may result in damage to the device or the controls.

The DH90 plugs into a common grounded 115VAC outlet. The device draws 6.2 Amps under normal operating conditions. If used in an area which may become wet, a ground fault interrupter (GFI) protected circuit is recommended.

**IMPORTANT:** Do not install the humidistat where it may not accurately sense the relative humidity such as near HVAC supply registers, near exterior doors, on an outside wall, near a window, or near a water source.

Refer to Section 6 for typical hookup diagrams. Some of the control wires leaving the DH90 may not be used with certain installations and should be left unconnected with wire nuts taped onto the stripped ends for safety.

#### 4.3 Condensate (Water) Removal

The DH90 removes a large amount of moisture from the air and the device must be connected to a drain line that will carry away the excess water. A trap in the drain line is recommended and may be required by some local codes.

The drain line should be connected to the 3/4" male pipe thread adaptor on the front of the DH90.

Care should be taken to install the drain line with a continuous slope of 1" per 10' to assure proper water removal.

#### 4.4 Ducting

**IMPORTANT:** When connecting ventilation duct, remove the label and 6" round insulation plug from the ventilation duct opening. If not using ventilation feature, leave the insulation intact.

For the ideal installation, draw air from the central part of the home and return it to the isolated areas of the home like the bedrooms, den, utility room, or family room. See Fig. 1. Alternative installation option can be completed by drawing air directly from the return ducting and distributing through the supply air to the home.

#### 4.4A Fresh Air / Supply Air

**IMPORTANT:** DO NOT draw air directly from the kitchen, laundry, or isolated basement.

Air may be drawn from a basement that is open to the home. All flexible ducting connected to the DH90 should be UL listed.

A short piece of flexible ducting on all DH90 duct connections is recommended to reduce noise and vibration transmitted to rigid ductwork in the structure. Ducting the DH90 as mentioned requires consideration of the following points:

- **Duct Sizing:** For total duct lengths up to 25', use a minimum 10" diameter round or

Figure 1: Ducting to isolated areas.

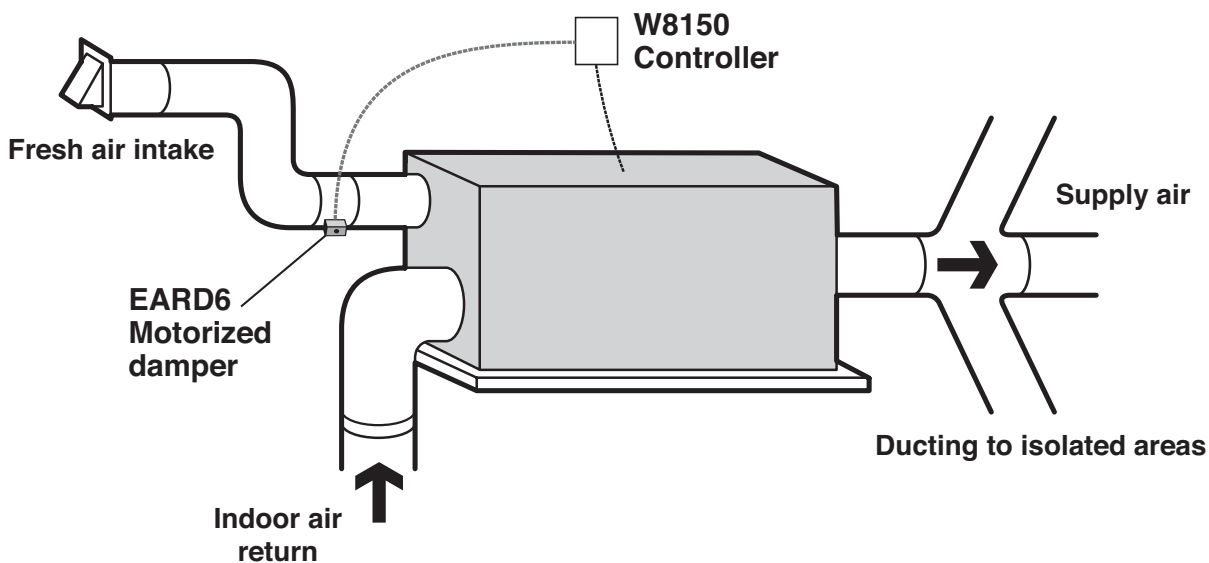

equivalent rectangular. For longer lengths, use a minimum 12" diameter or equivalent. Grills or diffusers on the duct ends must not excessively restrict airflow.

- **Isolated Areas:** Effective dehumidification may require that ducting be branched to isolated, stagnant air flow areas.

Use 8" or larger diameter branch ducting to each of two or three areas, use 6" or larger to each of four or more areas. Provisions must be made to provide airflow from supply locations to central return location. Proper air distribution is important to ensure even humidity control throughout the structure.

#### 4.4B Ducting for Fresh Air — Option

Fresh air may be brought into the structure by connecting an insulated duct from outside the structure to the 6" inlet of the DH90. Advantages of this form of ventilation include:

1. Outside air is filtered before entering the building.
2. Outside air will be dehumidified before entering if the DH90 is running in dehumidification mode.
3. Drawing air from outside and blowing inside aids in slightly pressurizing the

structure. This helps prevent dirty and humid air from entering elsewhere.

Exhaust fans are recommended in the bathrooms and kitchen.

An insulated 6" diameter duct is generally sufficient to provide up to 75 CFM of outside air. Large quantities of outside air will impact DH90 performance positively or negatively, depending upon the inside and outside air conditions.

The outside air duct should be connected to the 6" round collar on the side of the unit. The amount of outside air can be restricted by the blade damper in the 6" collar. The actual amount of ventilation air being delivered through the ventilation ducts must be measured in each installation. Refer to the instructions provided with the W8150 Ventilation Control for proper setup instructions.

#### 4.4C Installation in a Basement or Crawl Space with an Existing Forced Air HVAC System

Install a separate 10" return for the DH90 in a central area of the structure. Optional: Duct the supply of the DH90 to a 10" x 10" x 10" tee/damper, adjusted to 20% open to the basement. Duct the other side of the tee to the air supply of the existing HVAC system with a backdraft damper. Connect a duct from outside to the 6" collar of the DH90 if you wish to provide ventilation air. See Figure 2.

Figure 2: Basement or crawlspace installation.

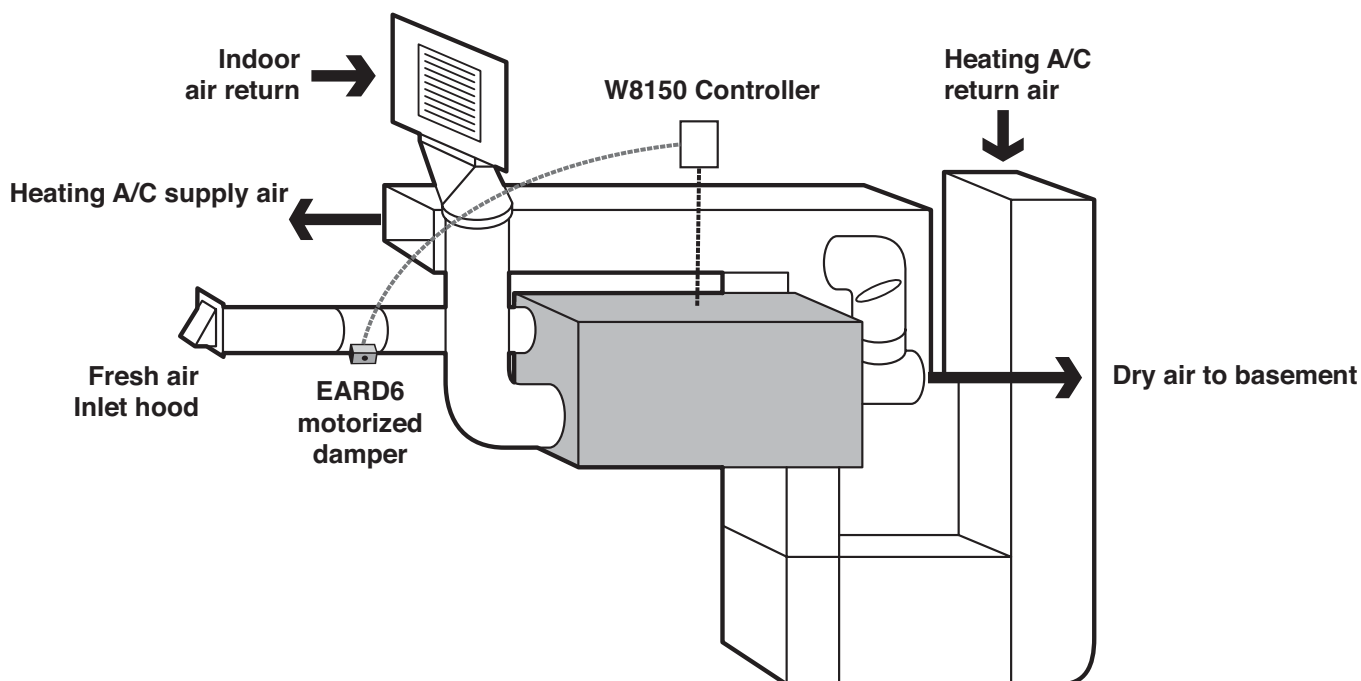

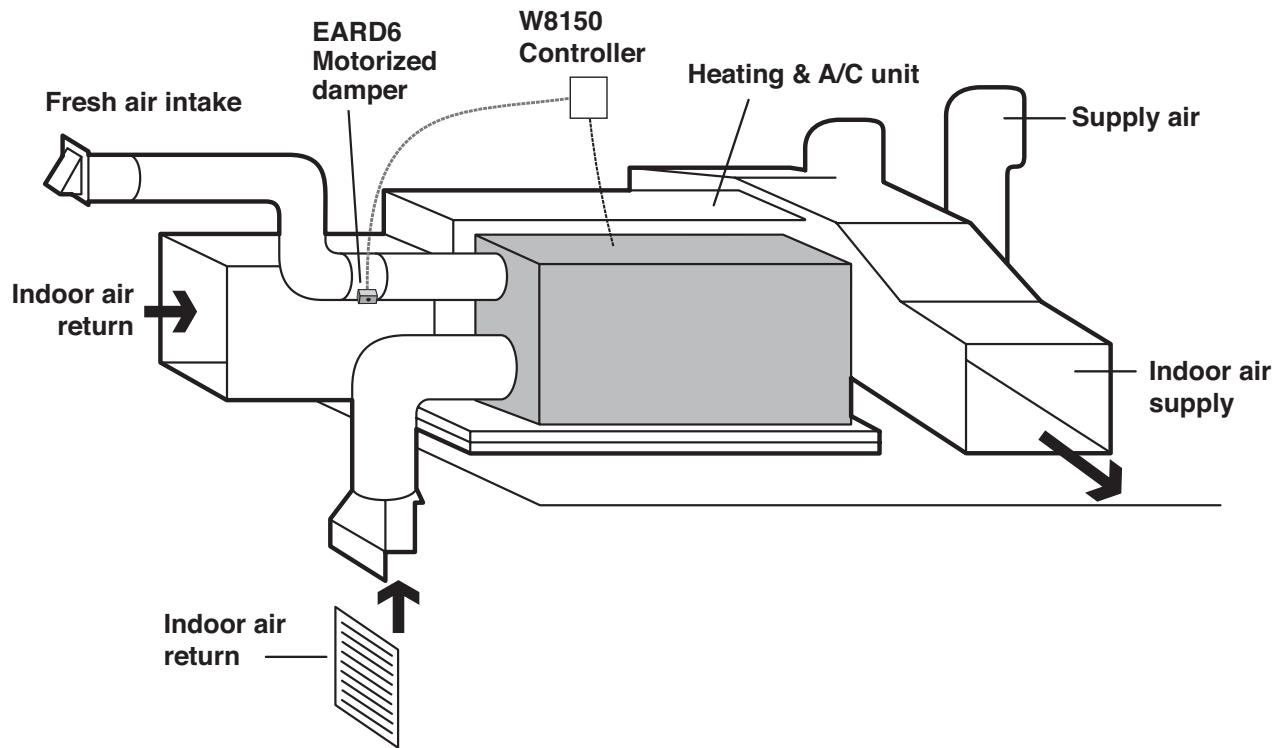

**Figure 3:** Attic Installation.

Instead of installing a separate return to the DH90, and if the existing system has multiple returns, it is possible to select one to disconnect from the existing forced air system and use it for the dedicated DH90 return. Always select a return from a central location in the structure in an area that is always open to the rest of the structure. Do not use a return from a room that may have its door closed much of the time.

#### 4.4D Installation in an Attic with an Existing Forced Air HVAC System

**IMPORTANT:** ALWAYS install a catch pan with a drain or float interrupt for condensate under the DH90 in an attic or condensate may damage the living space below.

The interrupt switch should be installed in series with the field wire that connects the blue lead from the DH90 to the dehumidistat. If overflow occurs, this switch opens the compressor control circuit and stops water production before the catch pan overflows. The DH90 will continue to ventilate or circulate air as normal, but will not dehumidify until this switch closes.

The preferred method of installation is to create a separate return for the DH90 in a central area of the structure. Duct the supply of the DH90 to the air supply of the existing HVAC system. Connect an insulated duct from outside to the 6" collar of the DH90 if you wish to provide fresh air. Adjust a damper in the duct to provide the desired amount of fresh air. See Figure 3.

#### 4.4E Installation in a Structure with No Existing Forced Air HVAC System

When installing the DH90 in a structure that does not have a forced air HVAC system, a single return for the DH90 should be installed in central open area of the structure.

DO NOT locate the return in a bathroom or a kitchen. The supplies of the DH90 should be located in the remote areas of the structure (such as bedrooms, den, etc.). By ducting this way, the air inside the structure will circulate through the DH90 to be filtered and dehumidified.

6" diameter duct is recommended for branches to the bedrooms, 8" diameter duct is recommended for branches to larger areas. Connect an insulated duct from outside to the 6" collar of the DH90 if you wish to provide ventilation. See Figure 4.

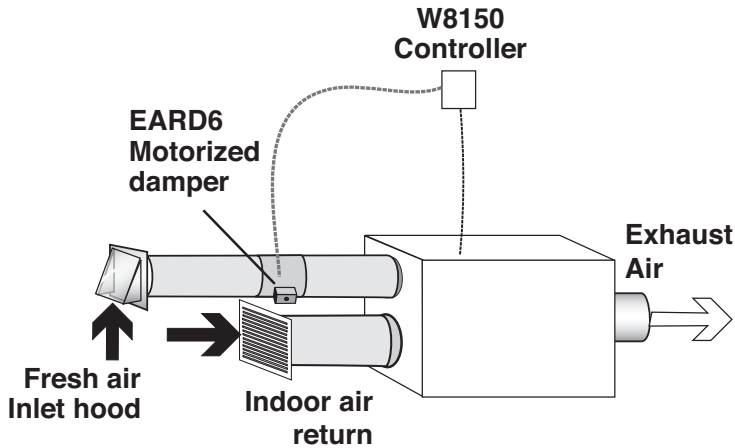

Figure 4: Install with no forced air HVAC system.

### 4.5 Noise Abatement

A length of 10' or more of acoustical flex ducting on the outlet of the DH90 will reduce air noise from the fan. A length of flexible ducting on all DH90 duct connections is recommended to reduce noise transmitted to rigid ductwork in the structure.

## 6. Wiring Diagrams

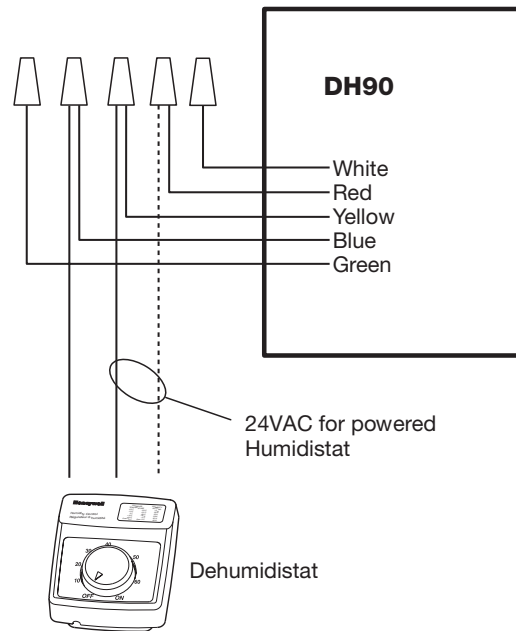

Figure 5: Dehumidistat only—No fresh air ventilation.

## 5. Maintenance

### 5.1 Air Filter

The DH90 is equipped with a MERV 11 media filter. This filter should be checked every three months and replaced every six months. Operating the unit with a dirty filter will reduce dehumidifier capacity and efficiency and may cause the compressor to cycle off and on unnecessarily on the defrost control.

**CAUTION:** Operate the unit only with a genuine Honeywell filter installed to assure proper performance of the unit.

### 5.2 Optional Fresh Air Intake

Check and clean the screen on the outdoor fresh air intake port seasonally. The screen may become plugged during the seasons when there are many particles in the outdoor air.

Figure 6: Dehumidistat including fresh air ventilation.

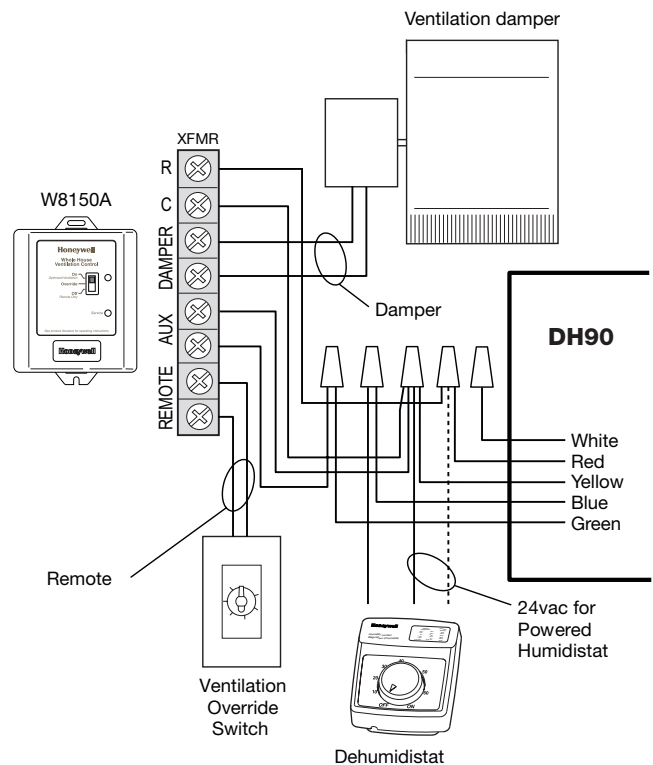

6.1 Choose the correct wiring diagram based on HVAC system

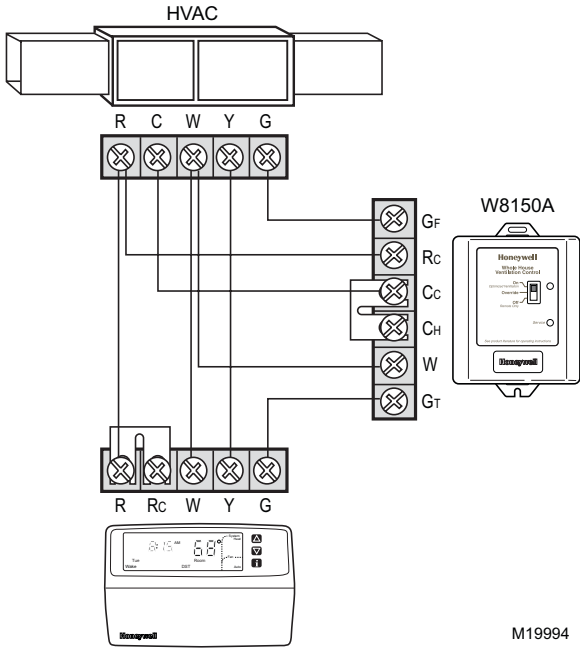

Figure 7: Single transformer, conventional system.

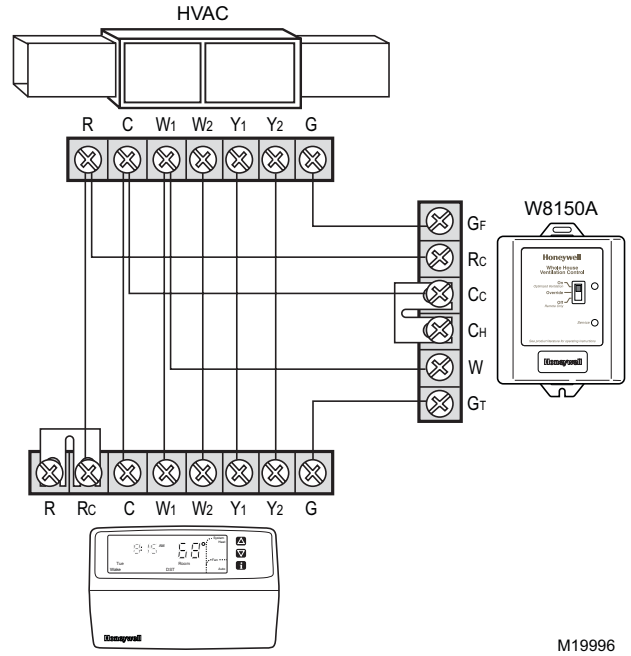

Figure 9: Multi-stage conventional system.

Figure 8: Dual transformer, conventional system.

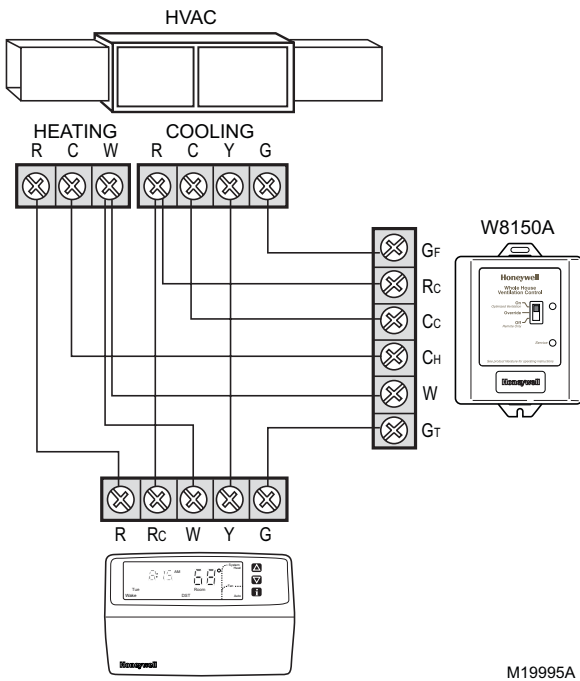
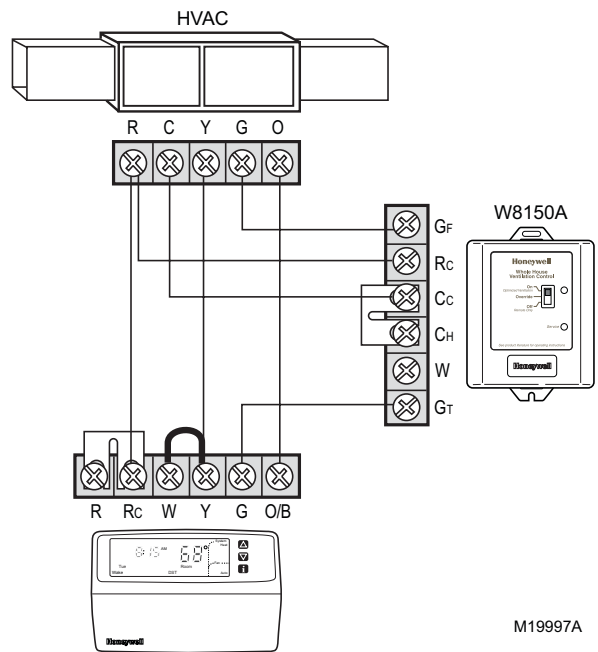
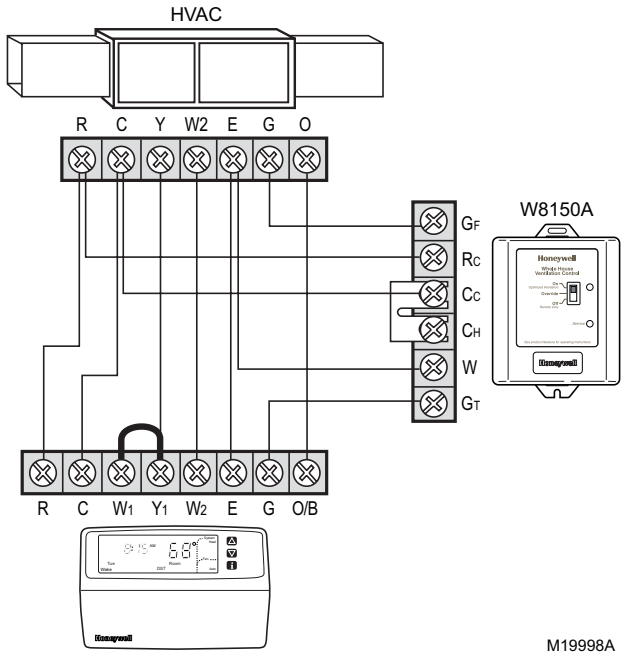

Figure 10: Wiring heat pump without emergency heat.







M19998A

Figure 11: Wiring heat pump with emergency heat.

## 7. Parts List

For replacement parts call: **1-800-345-6770**.

- DH90A1007 — DH90 Dehumidifier
- EARD6 — Motorized Damper
- 50018994-001 — 14" x 14" x 1" MERV 11 Filter
- 50018995-001 — 10" Back Draft Damper

## 8. Setting the control

1. Be sure power is turned on.
2. Set the Ventilation Standard on the control.
3. Set the bedrooms dial.
4. Set the area (sq ft) dial.
5. Set the airflow (cfm) dial.
6. Press the test button and observe the lights:

### Green light is flashing.

The dial settings meet the chosen standard.

### Red light is flashing.

There is not enough fresh air delivered to meet the requirements of the selected standard. See Troubleshooting section.

7. Record settings on the label inside the cover as shown in the diagram.

## TIPS:

- Ventilation control reads new dial setting only when test button is pushed or power is cycled. To ensure dial settings are read, push test button after any changes are made.
- For single bedroom homes, set the bedrooms dial to 2 (this may result in more ventilation than the minimum required).
- For homes having more than five bedrooms and only a single ventilation system, set the bedrooms dial to 5 (this may result in less ventilation than the minimum required).
- For conditioned square feet, set area (sq ft) dial to the nearest value.
- For airflow, set airflow (cfm) dial to the nearest value.
- Vaulted ceilings do not need to be considered when setting this control.
- For homes with multiple systems: Honeywell recommends a ventilation control and fresh air intake for each system. Measure ventilation airflow for each system independently. Refer to Multi-system Setup Example for further details.

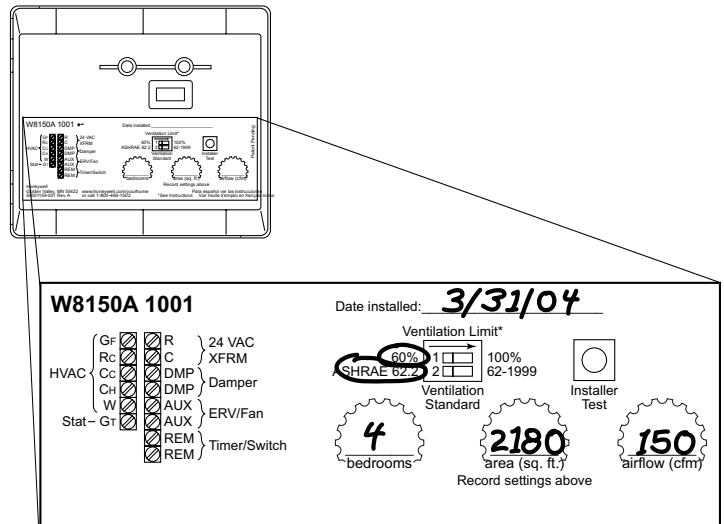

## 9. Service



**CAUTION:** Servicing the DH90 with its high pressure refrigerant system and high voltage circuitry presents a health hazard which could result in death, serious bodily injury, and/or property damage. Service should only be performed by a qualified service technician.

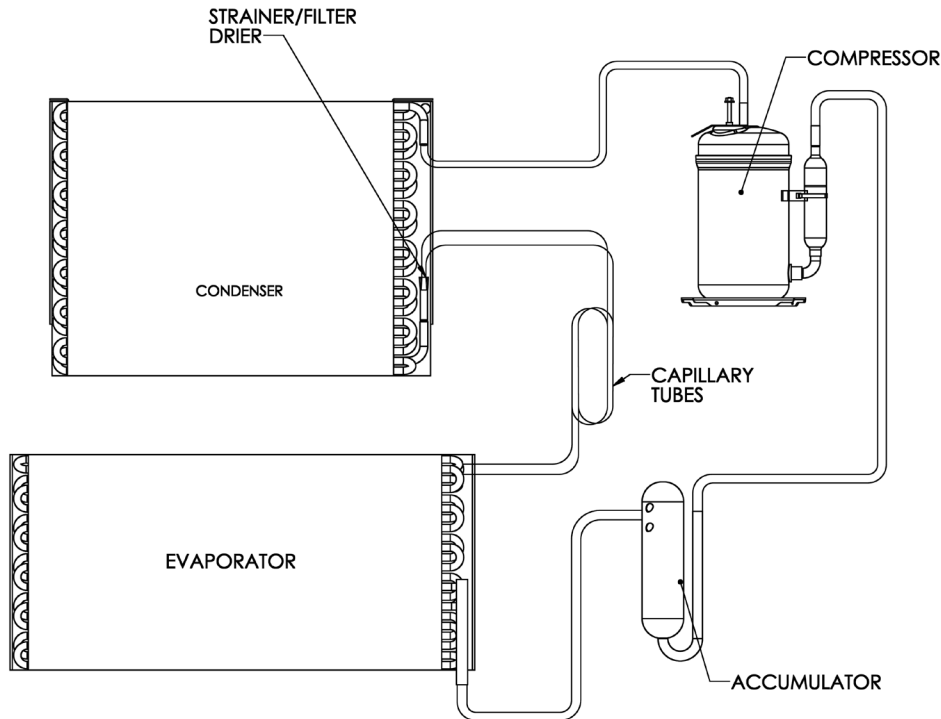

### 9.1 Troubleshooting

**No dehumidification, neither fan nor compressor run with fan switch and ventilation timer OFF.**

1. Unit unplugged or no power to outlet.
2. Humidity control set too high or defective.
3. Loose connection in internal or control wiring.
4. Defective Compressor relay.
5. Defective control transformer.
6. Low pressure control open.
7. Optional Condensate Pump Safety Switch open.

**No dehumidification, compressor does not run but fan runs when there is a call for dehumidification and the ventilation control is OFF.**

1. Defective compressor run capacitor.
2. Bad connection in compressor circuit.
3. Defective compressor overload.

4. Defective compressor.
5. Defrost thermostat open.
6. Optional Condensate Pump Safety Switch open.

**Fan runs when there is a call for dehumidification and the ventilation control is OFF, but the compressor cycles on and off too frequently.**

1. Low ambient temperature and/or humidity causing unit to cycle through defrost mode.
2. Defective compressor overload.
3. Defective compressor.
4. Defrost thermostat defective.
5. Dirty air filter(s) or airflow restricted.
6. Low refrigerant charge, causing defrost control to cycle.
7. Bad connection in compressor circuit. Fan does not run with fan switch in either position.

**Fan does not run with ventilation activated. Compressor runs briefly but cycles on & off with humidity control turned to ON.**

1. Loose connection in fan circuit.
2. Obstruction prevents fan rotation.
3. Defective fan.
4. Defective fan relay.
5. Defective fan capacitor.

**Evaporator coil frosted continuously, low dehumidifying capacity.**

1. Defrost thermostat loose or defective.
2. Low refrigerant charge.
3. Dirty air filter(s) or airflow restricted.

**Unit not providing ventilation.**

1. Check control wire connections (check connections at fresh air damper also).
2. Defective fresh air damper.
3. Dirty air intake. Clean outside intake hood.

**Unit removes some water, but not as much as expected.**

1. Air temperature and/or humidity have dropped.
2. Humidity meter and or thermometer used are out of calibration.
3. Unit has entered defrost cycle.
4. Air filter dirty.
5. Defective defrost thermostat.
6. Low refrigerant charge.
7. Air leak such as loose cover or ducting leaks.
8. Defective compressor.
9. Restrictive ducting.
10. Optional Condensate Pump Safety Switch open.

**Unit Test to determine problem:**

1. Detach field control wiring connections from main unit.
2. Connect the yellow and green pigtails from the main unit together; only the impeller fan should run. Disconnect the wires.
3. Connect the yellow and blue pigtails from the main unit together; the compressor and impeller fan should run.
4. If these tests work, the main unit is working properly. You should check the control panel and field control wiring for problems next.
5. Remove the control panel from the mounting box and detach it from the field installed control wiring. Connect the blue, yellow, and green wires from the control panel directly to the corresponding colored pigtails on the main unit. Leave the violet, white, and red wires disconnected!
6. Turn on the fan switch; the impeller fan should run. Turn off the fan switch.
7. Turn on the humidity control; the compressor and impeller fan should run.
8. If these tests work, the problem is most likely in the field control wiring.

## 9.2 Refrigerant Charging

If the refrigerant charge is lost due to service or a leak, a new charge must be accurately weighed in. If any of the old charge is left in the system, it must be recovered before weighing in the new charge. Refer to the unit nameplate for the correct charge weight and refrigerant type.

## 9.3 Compressor/Capacitor Replacement

This compressor is equipped with a two terminal external overload and a run capacitor, but no start capacitor or relay.



**CAUTION-ELECTRICAL SHOCK HAZARD:** Electrical power must be present to perform some tests. These tests should be performed by a qualified service person.

## Warranty Information

Honeywell warrants this product, excluding battery, to be free from defects in the workmanship or materials, under normal use and service, for a period of five (5) years from the date of purchase by the consumer. If at any time during the warranty period the product is determined to be defective or malfunctions, Honeywell shall repair or replace it (at Honeywell's option).

If the product is defective, Contact your installing contractor for return information.

This warranty does not cover removal or reinstallation costs. This warranty shall not apply if it is shown by Honeywell that the defect or malfunction was caused by damage which occurred while the product was in the possession of a consumer.

Honeywell's sole responsibility shall be to repair or replace the product within the terms stated above. HONEYWELL SHALL NOT BE LIABLE FOR ANY LOSS OR DAMAGE OF ANY KIND, INCLUDING ANY INCIDENTAL OR CONSEQUENTIAL DAMAGES RESULTING, DIRECTLY OR INDIRECTLY, FROM ANY BREACH OF ANY WARRANTY, EXPRESS OR IMPLIED, OR ANY OTHER FAILURE OF THIS PRODUCT. Some states do not allow the exclusion or limitation of incidental or consequential damages, so this limitation may not apply to you.

THIS WARRANTY IS THE ONLY EXPRESS WARRANTY HONEYWELL MAKES ON THIS PRODUCT. THE DURATION OF ANY IMPLIED WARRANTIES, INCLUDING THE WARRANTIES OF MERCHANTABILITY AND FITNESS FOR A PARTICULAR PURPOSE, IS HEREBY LIMITED TO THE FIVE-YEAR DURATION OF THIS WARRANTY. Some states do not allow limitations on how long an implied warranty lasts, so the above limitation may not apply to you.

This warranty gives you specific legal rights, and you may have other rights which vary from state to state.

If you have any questions concerning this warranty, please write Honeywell Customer Relations, 1985 Douglas Dr, Golden Valley, MN 55422 or call 1-800-468-1502. In Canada, write Retail Products ON15-02H, Honeywell Limited/Honeywell Limitée, 35 Dynamic Drive, Scarborough, Ontario M1V 4Z9.

## Automation and Control Solutions

Honeywell International Inc.  
1985 Douglas Drive North  
Golden Valley, MN 55422  
<http://yourhome.honeywell.com>

Honeywell Limited/Honeywell Limitée  
35 Dynamic Drive  
Toronto, Ontario M1V 4Z9

**Thank you for choosing a high performance  
Honeywell Indoor Air Quality product**



Printed in U.S.A. on recycled paper containing at least 10% post-consumer paper fibers.

® U.S. Registered Trademark.  
© 2006 Honeywell International Inc.  
69-1951 M.S. 06-06

# Honeywell