

G300AV • G300AVS

CHAINSAWS

Thank you very much for choosing our quality product.

This manual explains how to make most use of your unit.

Please read carefully before starting operation.

Should you have any trouble with your unit, please consult our local dealer or us directly.

The contents of this manual are accurate at the time of issue but may be changed without notice.

Contents

1. For Safe Operation
2. Specifications
3. Installing Guide bar and Saw chain
4. Fuel and Chain oil
5. Operating Engine
6. Sawing
7. Maintenance
8. Troubleshooting Guide

1. For Safe Operation

1. Never operate a chain saw when you are fatigued.
2. Use safety footwear, snug fitting clothing and eye, hearing and head protection devices.
3. Always use caution when handling fuel. Move the chain saw at least ten (10) feet (three (3) m) from the fueling point before starting the engine.
4. Do not allow other persons to be near the chain saw when starting or cutting, keep bystanders and animals out of the work area.
5. Never start cutting until you have a clear work area, secure footing, and a planned retreat path from the falling tree.
6. Always hold the chain saw firmly with both hands when the engine is running. Use a firm grip with thumb and fingers encircling the chain saw handles.
7. Keep all parts of your body away from the saw chain when the engine is running.

8. Before you start the engine, make sure the saw chain is not contacting anything.
9. Always carry the chain saw with the engine stopped, the guide bar and saw chain to the rear, and the muffler away from your body.
10. Never operate a chain saw that is damaged, improperly adjusted, or is not completely and securely assembled. Be sure that the saw chain stops moving when the throttle control trigger is released.
11. Always shut off the engine before setting it down.
12. Use extreme caution when cutting small size brush and saplings because slender material may catch the saw chain and be whipped toward you or pull you off balance.
13. When cutting a limb that is under tension, be alert for spring back so that you will not be struck when the tension in the wood fibers is released.
14. Keep the handles dry, clean and free of oil or fuel mixture.
15. Operate the chain saw only in well ventilated areas.
16. Do not operate a chain saw in a tree unless specially trained to do so.
17. All chain saw service, other than the items listed in the Operator's Manual, should be performed by competent chain saw service personnel. (e.g., if improper tools are used to remove the flywheel, or if an improper tool is used to hold the fly-wheel in order to remove the clutch, structural damage to the flywheel could occur which could subsequently cause the fly-wheel to disintegrate).
18. Guard against kickback. Kickback is the upward motion of the guide bar which occurs when the saw chain at the nose of the guide bar contact an object. Kickback can lead to dangerous loss of control of the chain saw.
19. When transporting you chain saw, use the appropriate guide bar scabbard.

TO AVOID KICKBACK:

Hold the chain saw firmly with both hands. Do not overreach. Do not let the nose of the guide bar contact a log, branch, ground or any other obstruction. Cut at high engine speeds. Don't cut above shoulder height. Follow manufacturer's sharpening and maintenance instructions for the saw chain.

2. Specifications

| Model | | G300AV | G300AVS |
|------------------------|---------|--|-----------------|
| Power unit: | | | |
| Displacement | cc | 28.5 | |
| Fuel | | Mixture (Gasoline 25: Two cycle oil 1) | |
| Fuel tank capacity | lit. | 0.22 | |
| Chain oil | | Motor oil SAE 10W-30 | |
| Oil tank capacity | lit. | 0.13 | |
| Carburetor | | Diaphragm type | |
| Ignition system | | Solid-state | |
| Spark plug | | Champion CJ-8Y | |
| Oil feeding system | | Mechanical pump | |
| Sprocket | | 6 toothed | |
| Dimensions (L x W x H) | mm | 375 x 225 x 240 | 375 x 230 x 240 |
| Dry weight | kg | 3.3 | 3.5 |
| Cutting head: | | | |
| Guide bar | — Type | | Sprocket nose |
| | — Size | in. | 12 (standard) |
| Saw chain | — Type | | Oregon 91SG |
| | — Pitch | in. | 3/8 |
| | — Gauge | in. | 0.050 |

G300AVS is equipped with Chain Brake.

Specifications are subject to change without notice.

3. Installing Guide bar and Saw chain

A standard saw unit package contains the items as shown below.

- (1) Power unit
- (2) Bar Protector
- (3) Guide bar
- (4) Saw Chain
- (5) Socket Wrench

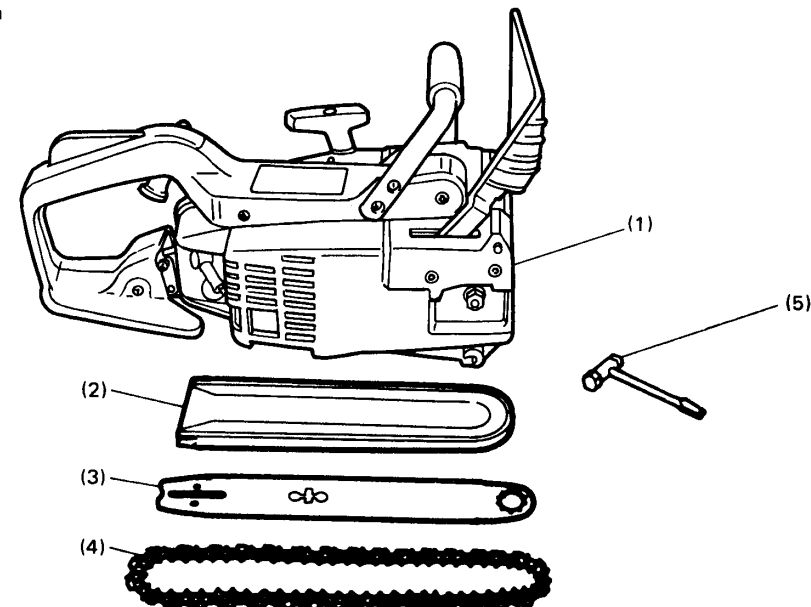

Open the box and install the guide bar and the saw chain on the power unit as follows.

⚠ The saw chain has very sharp edges. Use protective gloves for safety.

1. Loosen a nut and remove the chain cover.
2. Mount the guide bar then fit the saw chain around the bar and sprocket.

⚠ Pay attention to the correct direction of the saw chain

3. Fit the chain tensioner nut into the lower hole of the guide bar, then install the chain cover, and fasten the mounting nut to finger tightness.

- (1) Chain tensioner nut
(2) Moving direction

4. While holding up the tip of the bar, adjust the chain tension by turning the tensioner screw until the tie straps just touch the bottom side of the bar rail.
5. Tighten the mounting nut securely with the bar tip held up. Then check the chain for smooth rotation and correct tension while moving it by hand. If necessary, readjustment.
6. Tighten the tensioner screw.

⚠ It is very important to maintain the proper chain tension. Rapid wear of the guide bar or the chain coming off easily can be caused by improper tension. Especially when using a new chain, take good care of it since it should expand when first used

- (1) Loosen
(2) Tighten

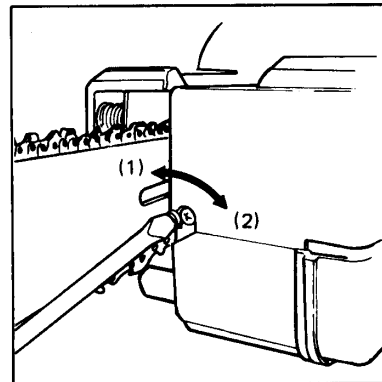
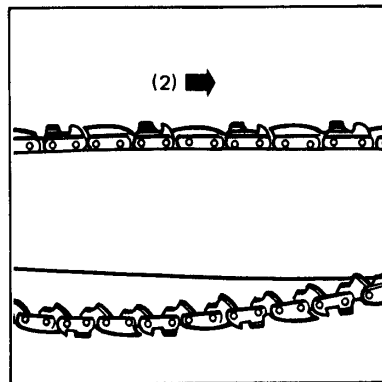
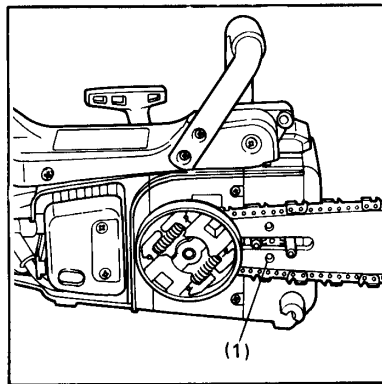

4. Fuel and Chain oil

Fuel

Mix gasoline and high quality 2-cycle oil in the ratio as shown below.

Gasoline Oil
25 : 1

- ⚠ Do not allow any fire in the area where fuel is handled.
- Do not allow water or dust in fuel containers.

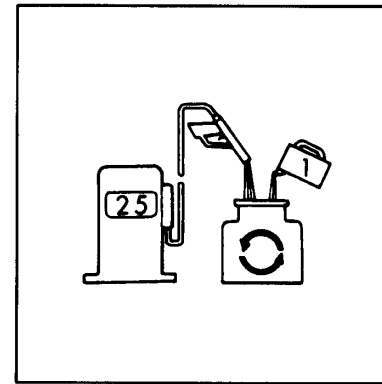

Chain oil

Use motor oil SAE 10W-30 all year round or SAE 30-40 in summer and SAE 10W in winter.

- ⚠ Do not use waste or regenerated oil that can cause damage to the oil pump.

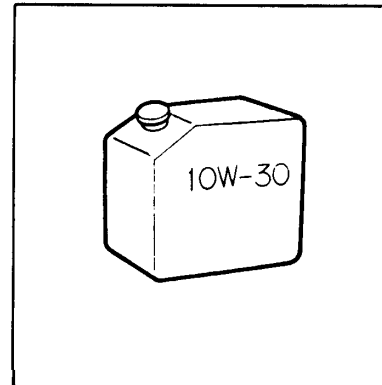

5. Operating Engine

Starting engine

1. Feed fuel and chain oil into their respective tanks and tighten the caps securely.

- (1) Fuel
(2) Chain oil

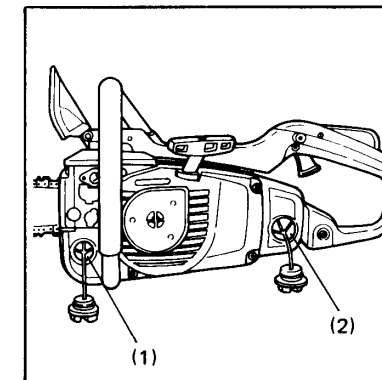

2. Put the switch to the "I" position.

- (1) Switch

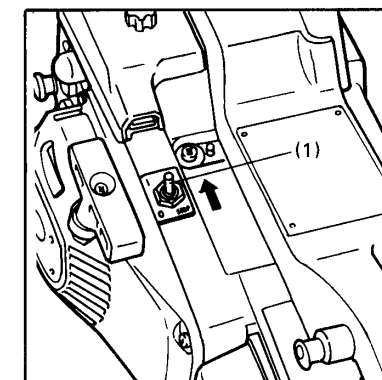

3. While holding the throttle lever together with the throttle interlock, push in the side latch and release the throttle lever to leave it at the starting position.

- (1) Throttle interlock
(2) Throttle lever
(3) Latch

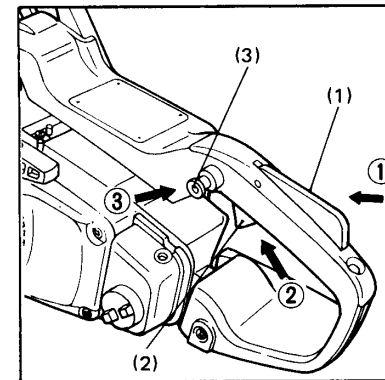

4. Pull out the choke knob to the closed position.

⚠ When restarting immediately after stopping the engine, leave the choke knob at the open position.

- (1) Choke knob

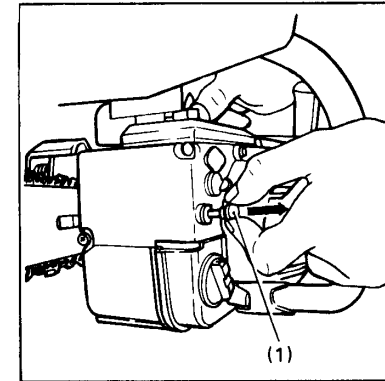

5. While holding the saw unit securely on the ground, pull the starter rope vigorously.
6. When firing occur, push in the choke knob and pull the starter again to start the engine.
7. Allow the engine to warm up with the throttle lever pulled slightly.

⚠ Before you start the engine, make sure the saw chain is not contacting anything.

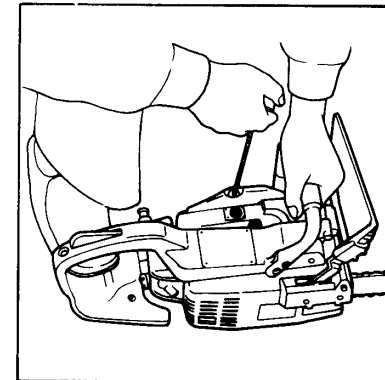

Checking oil supply

After starting the engine, run the chain at medium speed and see if chain oil is scattered off as shown in the figure.

- (1) Chain oil

⚠ The oil tank should become nearly empty by the time when fuel is used up. Be sure to refill the oil tank everytime when refueling the saw.

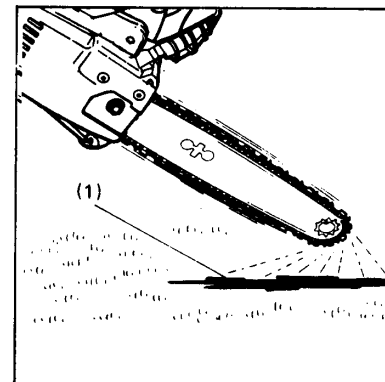

Adjusting carburetor

The carburetor has been adjusted at the factory. Should your unit need readjustment due to the changes in altitude or operating conditions, please let your skillful dealer make the adjustment. A wrong adjustment may cause damage to your unit. If you have to make the adjustment yourself, please follow the procedure below carefully.

⚠ Be sure to adjust the carburetor with the bar chain attached.

1. Stop engine and screw in both H and L needles until they stop. Never force. Then set them back the standard number of turns as shown below.

H needle: 1-1/4 ± 1/8
L needle: 1-1/2 ± 1/8

2. Start engine and allow it a few minutes warming up in low speed.
3. Turn L needle slowly clockwise to find the position where idling speed is maximum, set the needle back a quarter (1/4) turn counterclockwise. L needle should be set in 1/4 turn either wise from the standard position.
4. Turn idle adjusting screw (T) counterclockwise so that saw chain does not turn. If idling speed is too slow, turn the screw clockwise.
5. Make a test cut and adjust the H needle for best cutting power, not for maximum speed.

Chain brake

(G300AVS only)

The brake system is designed to stop the chain movement immediately when the front hand guard is pushed by the left hand (e.g. in case the chainsaw is kicked back). The brake is released by pulling the lever toward the front handle.

⚠ Running the engine at high speed for a long time with the brake working will result in the failure of clutch. When the brake has worked, release the throttle lever immediately and release the brake.

- (1) Front handle
- (2) Released
- (3) Braking
- (4) Brake lever

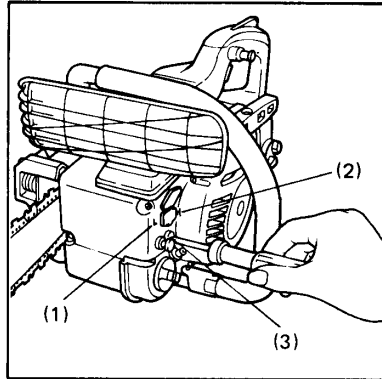

- (1) L needle
- (2) H needle
- (3) Idle adjusting screw

- (1) Aiguille L
- (2) Aiguille H
- (3) Vis de réglage

- (1) L-Nadel
- (2) H-Nadel
- (3) Leerlauf-Einstellschraube

- (1) Ago "L"
- (2) Ago "H"
- (3) Vite di regolazione della marcia al minimo

- (1) Aguja L
- (2) Aguja H
- (3) Tornillo de ajuste de ralentí

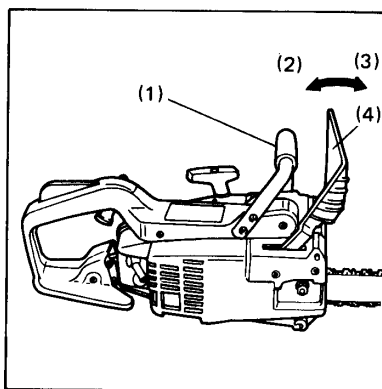

Stopping engine

1. Release the throttle lever to allow the engine idling for a few minutes.
2. Put the switch to the "O" position.

- (1) Switch

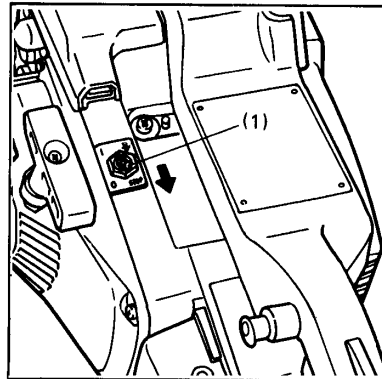

6. Sawing

⚠ Before proceeding to your job, read "For Safe Operation" section. It is recommended to practice the sawing of easy logs. This also helps you get accustomed to your unit.

- It is not necessary to force the saw into the cut. Apply only light pressure while running the engine at full throttle.
- Racing the engine with the chain seized in a cutway can damage the clutch. If the cutting head should be caught in the cutway, do not attempt to pull it out by force, but use a wedge or a lever to open the way.

Felling a tree

1. Decide the felling direction considering the wind, lean of the tree, location of heavy branches, ease of job after felling and other factors.
2. While clearing the area around the tree, arrange a good foothold and retreat path.
3. Make a notch cut one-third of the way into the tree on the felling side.
4. Make a felling cut from the opposite side of the notch and at a level slightly higher than the bottom of the notch.

⚠ When you fell a tree, be sure to warn your neighbouring workers of the danger.

- (1) Notch cut
- (2) Felling cut
- (3) Felling direction

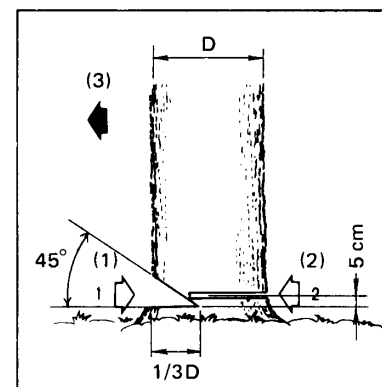

Logging and Limbing

- ⚠ Always ensure your foothold as well as stability of the tree.
- Be alert to the rolling over of a cut log.
- Read the instructions in "For Safe Operation" to avoid kick-back of the saw.

Case 1.

Saw down to the halfway, then roll the log over and cut from the opposite side.

Case 2.

In area A, saw up from the bottom one-third of the way and finish by sawing down from the top.

In area B, saw down from the top one-third of the way and finish by sawing up from the bottom.

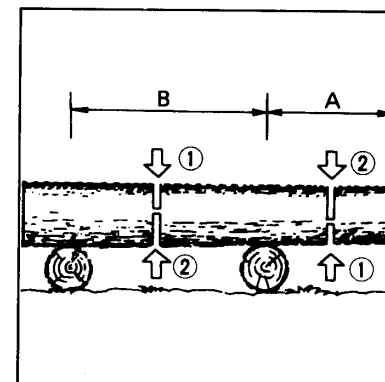
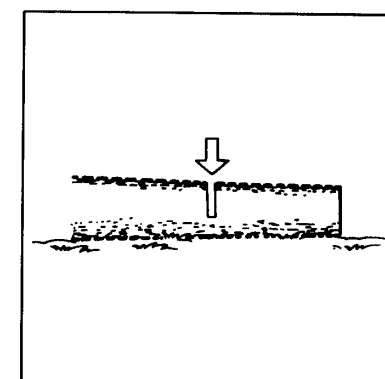

Case 3. (In limbing)

First check to which side the limb is bent. Then make the initial cut from the bent side and finish by sawing from the opposite side.

⚠ Be alert to the springing back of a cut limb.

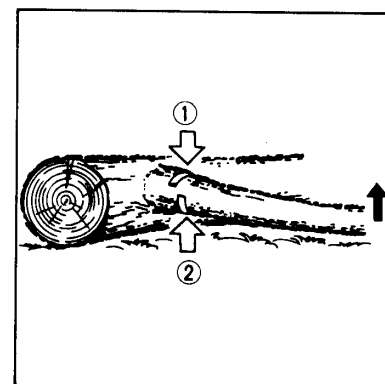

Pruning

Cut up from the bottom, finish down from the top.

- ⚠ Do not use an unstable foothold.
- Do not overreach.
- Do not cut above shoulder height.
- Always use both your hands to grip the saw.

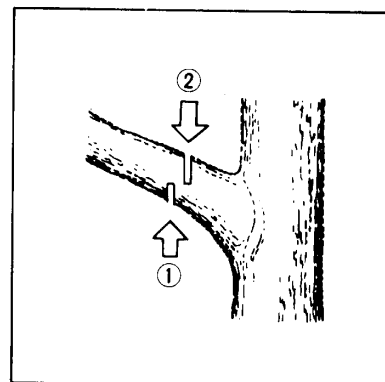

7. Maintenance

⚠ Make sure the engine is stopped.

A. Daily check points

1. Air filter

Loosen the knob and remove the air cleaner cover. Take off the filter elements and tap off attached sawdust. When they are extremely dirty, shake-wash with gasoline. Dry them completely before reinstalling.

(1) Air filter

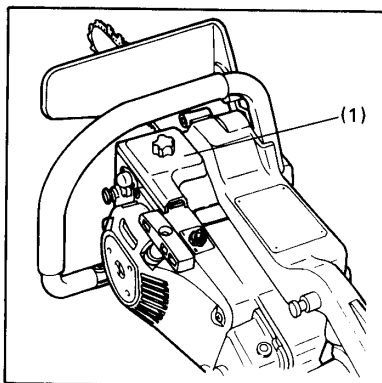

2. Oiling port

Dismount the guide bar and check the oiling port for clogging.

(1) Oiling port

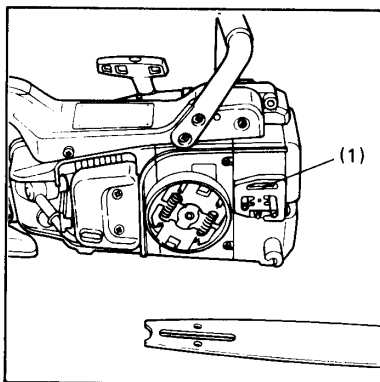

3. Guide bar

Remove sawdust in the bar groove and the oiling port.

(1) Groove
(2) Oiling port

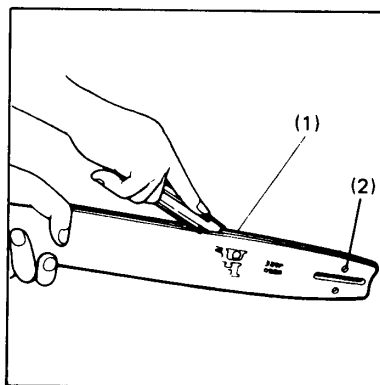

4. Spark plug

Clean the electrodes with a wire brush and adjust the gap to 0.6mm.

⚠ Replacement plug:
Champion CJ-8Y or RCJ-8Y
NGK BPM7A.

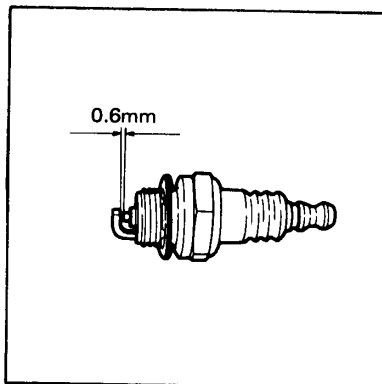

5. Sprocket

Check for extensive wear, and replace it when the teeth are worn over 1.0 mm.

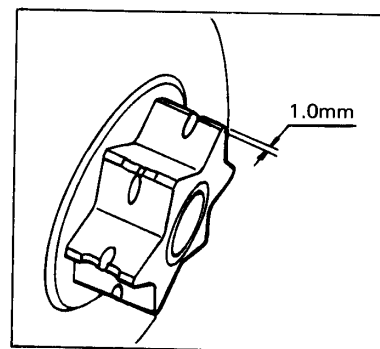

6. Guide bar

The bar rail should always be a square. Check for wear of the bar rail. Apply a ruler to the bar and the outside of a cutter. If a gap is observed between them, the rail is normal. Otherwise, the bar rail is worn. Such a bar needs to be corrected or replaced.

(1) Ruler
(2) Gap
(3) No gap
(4) Chain tilts

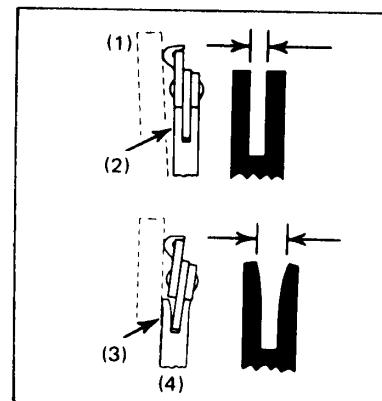

7. Handle mounting joints

Replace if adhered part is peeled or crack is observed on the rubber part. Replace if the inside of the rear damper metal has been beaten by the stopper bolt and the clearance of the metal increased.

After every cutter has been set, check the depth gauge and file it to the proper level as shown below.

⚠ Be sure to round off the front edge.

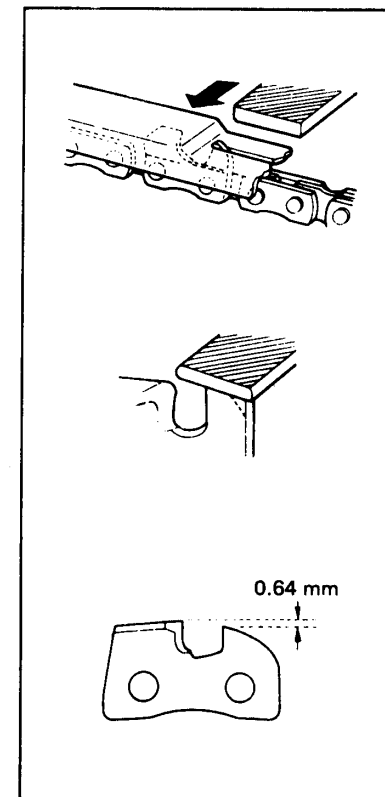

Make sure every cutter has the same length as well as the edge angles as shown on the right.

B. Guide Bar

Reverse the bar occasionally to prevent partial wear.

(1) Cutter length

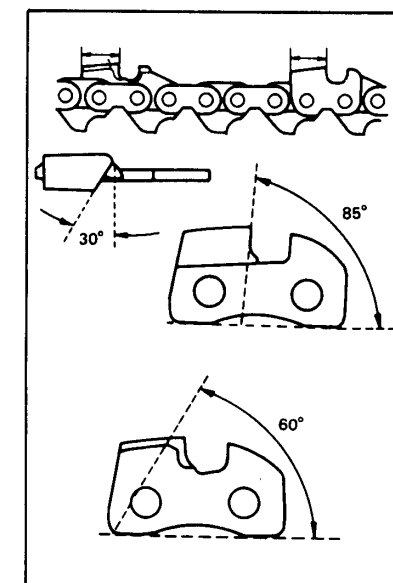

8. Troubleshooting Guide

Case 1. Starting failure:

 **Make sure the icing prevention system is not working.**

Check fuel for water or substandard mixture.



Replace with proper fuel.



Check for engine flooding.



Remove and dry the spark plug.
Then pull the starter again with no choke.



Check the spark.



Replace with a new plug.

Case 2. Lack of power/Poor acceleration/Rough idling

Check fuel for water or substandard mixture.



Replace with proper fuel.



Check air filter and fuel filter for clogging.



Clean.



Check carburetor for inadequate adjustment.



Readjust speed needles. (See page 17.)

Case 3. Oil does not come out

Check oil for substandard quality.



Replace.



Check oil passage and ports for clogging.



Clean.

When your unit seems to need further service, please consult our service shop in your area.