

SureMark 4610 Printers

*Programming Guide
for Models 1xR and 2xR*



SureMark 4610 Printers

*Programming Guide
for Models 1xR and 2xR*



Note

Before using this information and the products it support, be sure to read the general information in "Notices" on page 111, and the *Safety Information – Read This First* manual, GA27-4004, and *Warranty Documents* that ships with this product.

October 2011

This edition applies to IBM SureMark Printer Models 2xR and 1xR.

This edition replaces GA27-5005-01.

Current versions of the Retail Store Solutions documentation are available on the IBM Retail Store Solutions Website at www.ibm.com/solutions/retail/store/support. Select the product category and click on **Publications** to find the latest version of the document.

A form for reader's comments is also provided at the back of this publication. If the form has been removed, address your comments to:

IBM Corporation
Retail Store Solutions Information Development
Department ZBDA
PO Box 12195
Research Triangle Park, North Carolina 27709 USA

When you send information to IBM, you grant IBM a nonexclusive right to use or distribute whatever information you supply in any way it believes appropriate without incurring any obligation to you.

© **Copyright IBM Corporation 2008, 2011.**

US Government Users Restricted Rights – Use, duplication or disclosure restricted by GSA ADP Schedule Contract with IBM Corp.

Contents

Figures	vii
--------------------------	------------

Tables	ix
-------------------------	-----------

About this book xi

Who should read this guide	xi
How this guide is organized	xi
Related publications	xi
Publications accessibility	xii
Notice statements	xii
Providing feedback.	xii

Summary of changes xiii

October 2011.	xiii
June 2009	xiii
April 2009	xiii

Chapter 1. Introducing the 4610 Models

1xR and 2xR. 1

Operating system requirements	1
RS-232 interface	1
4690 OS	2
Hardware requirements.	2
Updating the firmware	3

Chapter 2. Communication parameters . 5

RS-232 serial parameter.	6
RS-232 commands summary by function	6
Alphabetized commands summary	10
System commands	13
Verify previous commands completed	13
Status request	13
Reset printer	13
EC/Request/Real-time status request.	14
Retrieve Native Mode Status (when printer is in compatibility mode)	14
Retrieve Native Mode Device ID (when printer is in compatibility mode)	14
Extended address command-request printer ID Printer ID format	15
Emulation mode for Model 1xR / 2xR	16
Emulation of Non-IBM printers.	17
Preset or onetime-set commands	18
Memory allocation	18
Double-byte characters	20
Download graphics (logo) commands	20
Predefine messages.	22
Download user-defined characters.	23
User-defined code page mapping	28
Request checksum of flash memory sector	29
Retrieve checksum of each downloaded logo or each stored message	29
Flash storage write	30
Erase flash sector	30

Microcode tolerance (MCT) information - loading	31
Microcode tolerance (MCT) information - request	31
Setup commands	35
Set print mode	35
Set or cancel double-wide mode	37
Set or cancel double-high mode	37
Set or cancel underline mode	38
Set or cancel overline mode	38
Set or cancel invert mode.	38
Set or cancel emphasized printing.	38
Select maximum print speed.	39
Set or cancel unidirectional printing	39
Set document length for landscape print.	39
Request document length for landscape print	40
Set print station	40
Select user-defined or resident character sets	41
Set code page.	41
Set intercharacter spacing for single byte character sets.	42
Set intercharacter spacing for double byte character sets.	42
Set or cancel rotated characters.	43
Set print station parameters	43
Select 1/8-inch line spacing	43
Select 1/6-inch line spacing	44
Select color printing	44
Set line spacing using minimum units	45
Set sheet eject length	45
Set horizontal tab positions	46
Set left margin position	46
Set right margin position	47
Set relative position.	47
Set low paper calibration	48
Align positions	48
Set error recovery function	49
Define document wait time	49
Status sent to system	50
Select character for reprinted lines.	50
Re-initialize the printer	51
Enable or disable the beeper.	51
Enable or disable the feed buttons	52
Enable or disable upside-down printing.	52
Select character size for scalable fonts	53
Fix font matrix	54
Print logo inline	54
Set or cancel strike-through	55
Select thermal paper	55
Bar code commands	56
Print bar code	56
Select horizontal size of bar code	61
Select bar code height	61
Select printing position of human readable information (HRI)	61
Select font for HRI	62
Print PDF417 bar code.	62

Select PDF417 ECC (error correction codewords) level	63
Select aspect ratio PDF417 bar code	63
Enable PDF417 truncation	64
Print character commands	64
Print and line feed	64
Print and line feed	64
Print, form feed, and cut the paper (FF)	64
Print and feed paper n lines	65
Print and feed paper using minimum units	65
Print graphic messages	65
Select and print a graphics (logo) command	65
Print predefined graphics (logo) command	67
Enable watermark printing	68
Print predefined messages	68
Check processing commands - 2CR only	69
MICR read	69
Flip check	71
Miscellaneous commands	71
Horizontal tab	71
Backspace for composite characters	71
Return home (select print head location)	72
Paper cut/DI eject	73
Generate drive pulse for cash drawer	73
Retrieve the flash storage	73
Retrieve size of user flash storage	74
Prepare printer for shut down (S3)	74
Asynchronous (real-time) commands	74
Real-time requests	74
Data buffer management and batch printing	76
Marker command	76
Reset line count	77
Disable line count	77
Hold printing until buffer is released	77
Release print buffer	78

Chapter 3. Page mode printing commands 79

Select page mode	79
Select standard mode	79
Select printable area	79
Select printing direction/position	80
Set vertical position	80
Set relative vertical position	80
Set left margin position (standard mode), set absolute print position (page mode)	81
Set relative horizontal position	81
Set printing position	82
Print, form feed and cut the paper	82
Print page in page mode	83
Clear print data in page mode	83

Chapter 4. Document handling 85

Portrait mode	85
Landscape mode	86
Landscape printing commands	86

Chapter 5. Status information 89

Message from the printer	89
Status byte 1	90

Status byte 2	90
Status byte 3	90
Status byte 4	91
Status byte 5	91
Status byte 6	91
Status byte 7	91
Status byte 8	92
Status byte 9	92
Status byte 10	93
Status byte 11	93
Status byte 12	93
Status byte 13	94
Status byte 14	94
Status byte 15	94
Status byte 16	95

Chapter 6. Character fonts 97

Thermal printing font	97
Proportional fonts	97
Preparing the fonts	97
Implementing proportional fonts	98
Layout using align commands	98
Layout using set tab position	99
Proportional font conversion utility	99

Chapter 7. Tests and diagnostics 101

Low paper sensing and calibration	101
Firmware offline tests (Models 2xR)	102
Summary of the offline test menus (Models 2xR)	103
Changing the interface card or logic card	104
Storing a new serial number in the firmware	105
Earlier methods for offline tests	106
Firmware offline tests (Models 1xR)	107
Summary of the offline test menus (Models 1xR)	108
Storing a new serial number in the firmware after a logic or interface card change	109
Customer receipt test	109

Notices 111

Electronic emission notices	113
Federal Communications Commission statement	113
European Union EMC Directive conformance statement	113
Industry Canada Class A Emission Compliance statement	114
Avis de conformité aux normes d'Industrie Canada	114
Germany	114
Australia and New Zealand	114
Chinese Class A warning statement	115
Japanese Electrical Appliance and Material Safety Law statement	115
Japanese power line harmonics compliance statement	115
Japanese VCCI Council Class A statement	115
Japan Electronics and Information Technology Industries Association (JEITA) statement	115
Korean communications statement	115
Taiwanese Class A warning statement	116
Taiwan contact information	116

Cable ferrite requirement 116
Electrostatic discharge 116
Product recycling and disposal 117
Battery return program 118
 For Taiwan: 118
 For the European Union: 119
 For California: 119

Flat panel displays 120
Monitors and workstations 120
Trademarks 120

Index 121

Figures

1. Proportional font example.	27	5. Example of the offline selection main menu	103
2. Composite Characters	72	6. Offline tests activation	107
3. Paper feed and document feed buttons	102	7. Example of the offline selection main menu	108
4. Pressing the power button	103		

Tables

1.	RS-232 operating systems supported	1	17.	Status byte 2	90
2.	Driver documentation by operating system	6	18.	Status byte 3	90
3.	RS-232 commands organized by function	6	19.	Status byte 5	91
4.	Commands in alphabetical order	10	20.	Status byte 7	91
5.	Device Type = 30.	15	21.	Status byte 8	92
6.	Printer memory allocation defaults.	19	22.	Status byte 9	92
7.	Unicode positions for code page 858 - 2 bytes for each mapping location	28	23.	Status byte 10.	93
8.	MCT command definitions	31	24.	Status byte 11.	93
9.	Print characteristics	35	25.	Status byte 12.	93
10.	Characters that select font A, B, and C	35	26.	Status byte 13.	94
11.	Width and height for scalable fonts	53	27.	Status byte 14.	94
12.	Code 128 character set	58	28.	Status byte 15.	94
13.	Print bar code examples	61	29.	Status byte 16.	95
14.	Print direction	80	30.	MCT load command settings for low paper and critically low paper	101
15.	Summary of status conditions	89	31.	Summary of the offline test menu items	103
16.	Status byte 1	90	32.	Summary of the offline test menu items	108

About this book

This guide provides programming commands and other technical information for your IBM SureMark Models 2xR and 1xR printers.

Who should read this guide

This guide is intended for use by programming personnel who are installing, setting up, or modifying the IBM SureMark printer Models 2xR and 1xR.

How this guide is organized

This publication is organized as follows:

- Chapter 1, "Introducing the 4610 Models 1xR and 2xR," on page 1 describes the hardware features of the 4610 Models 2xR and 1xR.
- Chapter 2, "Communication parameters," on page 5 provides the communication variables and commands required to customize your printer.
- Chapter 3, "Page mode printing commands," on page 79 describes the communication parameters for page mode printing.
- Chapter 4, "Document handling," on page 85 describes the communication parameters for document handling.
- Chapter 5, "Status information," on page 89 describes the communication parameters for the byte status information.
- Chapter 6, "Character fonts," on page 97 describes the communication parameters for the character fonts.
- Chapter 7, "Tests and diagnostics," on page 101 is an overview of the MICR and flipper tests, and the offline diagnostic tests available on the Models 2xR and 1xR.

Related publications

The following IBM publications are available from the IBM Retail Store Solutions Web site at www.ibm.com/solutions/retail/store/support. Select **Publications**.

- *Safety Information – Read This First*, GA27-4004
- *IBM SureMark Printers: User's Guide for Models 2CR and 2NR*, GA27-5003
- *IBM SureMark Printers: Hardware Service Guide for Models 2CR and 2NR*, GA27-5004
- *IBM SurePOS 700 Series: System Reference*, SA27-4224
- *IBM SurePOS 500 Series: System Reference*, SA27-4255.
- *POSS Programming Reference and User's Guide*, SC30-3560.

The following IBM printers and point-of-sales terminals require the following diskettes, which can be downloaded from the IBM Retail Store Solutions Website at www.ibm.com/solutions/retail/store/support. Select **Other Systems and Devices** under *Peripherals*.

- *IBM SureMark 4610 Printers: Fonts and Logos Utility Diskette*
- *IBM SureMark 4610 Printers: Firmware Update Diskettes*
- *IBM 4693 Point-of-Sale Terminals Reference Diskette*

Publications accessibility

The softcopy version of this guide and other related publications are accessibility enabled.

Notice statements

Notices in this guide are defined as follows:

Notes	These notices provide important tips, guidance, or advice.
Important	These notices provide information or advice that might help you avoid inconvenient or problem situations.
Attention	These notices indicate potential damage to programs, devices, or data. An attention notice is placed just before the instruction or situation in which damage could occur.
CAUTION	These statements indicate situations that can be potentially hazardous to you. A caution statement is placed just before the description of a potentially hazardous procedure step or situation.
DANGER	These statements indicate situations that can be potentially lethal or extremely hazardous to you. A danger statement is placed just before the description of a potentially lethal or extremely hazardous procedure step or situation.

Providing feedback

Your feedback is important in helping IBM provide accurate and high-quality information.

To provide feedback to IBM:

- Print the reader's comment form included in the back of this document.
- Complete the form, including a reference to the specific location of the text (for example, the page or table number) in question.
- Return the completed form to IBM by mail or you can give the form to an IBM representative.

Between major revisions of this document, there might be minor technical updates. The latest version of this document is available on the IBM Retail Store Solutions Website at www.ibm.com/solutions/retail/store/support/. Click **Publications** to search for the most current version of this document.

Summary of changes

October 2011

This update provides additional changes throughout the entire book from the new spec and the subject matter expert.

Changes or additions to the text are indicated by a change bar to the left of the text.

June 2009

This update provides additional changes throughout the entire book from the new spec and the subject matter expert.

April 2009

This update provides changes throughout the book from the new spec.

Chapter 1. Introducing the 4610 Models 1xR and 2xR

The IBM SureMark printer Models 1xR and 2xR printers consist of a high-speed thermal station and an impact station for printing inserted documents. For further information about the physical specifications of Models 2xR and 1xR, refer to the *User's Guide for Models 2xR and 1xR*, GA27-5003-00.

Operating system requirements

Drivers can be downloaded from the Retail Store Solutions Web site at www.ibm.com/solutions/retail/store/support/.

RS-232 interface

The RS-232 interface supports systems with the following operating systems:

Table 1. RS-232 operating systems supported

Operating System	JavaPOS Drivers 1.9.6 or later	OPOS Drivers 1.9.6 or later	POS Subsystem 1.9.6 or later	Windows Native Drivers (NWD)	Direct IO	Comments
IBM 4690					Yes	V5R2 and V6R2*
Windows XP	Yes	Yes		Yes	Yes	
Microsoft Windows Embedded for Point of Service (WEPOS) 1.11	Yes	Yes		Yes	Yes	
Microsoft Windows Embedded POSReady 2009	Yes	Yes		Yes	Yes	
Microsoft Windows 7 (Professional/Ultimate)	Yes	Yes		Yes	Yes	
IBM Retail Environment for SUSE Linux (IRES)	Yes				Yes	
Novell Linux Point of Service (NLPOS)	Yes				Yes	
SUSE Linux Enterprise Desktop (SLED) 11	Yes				Yes	
SUSE Linux Enterprise Server (SLES) 11	Yes				Yes	

Table 1. RS-232 operating systems supported (continued)

Operating System	JavaPOS Drivers 1.9.6 or later	OPOS Drivers 1.9.6 or later	POS Subsystem 1.9.6 or later	Windows Native Drivers (NWD)	Direct IO	Comments
SUSE Linux Enterprise Point of Service (SLEPOS) 11	Yes				Yes	
PC DOS 2000					Yes	
* The 2NR/2CR printers are supported in compatibility mode in V5R2, but 4690 OS can only update the firmware starting with the 0820 maintenance package. The 1NR is supported in compatibility mode in V5R2, but requires package 0900 for firmware update. All of these models are supported in compatibility or native mode in V6R2.7.						

4690 OS

Customers must be at these application levels (or higher) when running the 4690 OS:

Application Name	Product Number	Maintenance Level
Note: Some of these applications will only support the printers if they are set in TI3/4 compatibility mode.		
IBM SUREPOS Application Client/Server Environment for 4690 OS	5745-C44	N/A
IBM Chain Drug Sales Application	5669-212	9701 with PRPQ 5799-QYP
IBM 4680/4690 General Sales Application	5696-546	9701 with APAR IR33229 and PRPQ 5799-QYN
IBM 4680/4690 Supermarket Application	5696-536	9701 with APAR IR33228 plus PRPQ 5799-QYL
Linux	See note	Release 1.4
Note: 4690 Terminal Services for Windows NT is required when you use Windows NT 4.0 or Windows 2000 as the primary operating system with this 4690 application.		

Hardware requirements

SureMark printers operate with the following systems:

- IBM 4694
- IBM 4695 (RS-232 connection only and with power supply)
- PC or other store controller with an RS-232 or USB port
- SurePOS 100 Series
- SurePOS 700 Series
- SurePOS 500 Series
- SurePOS 300 Series
- IBM Self Checkout
- IBM Anyplace Kiosk

Updating the firmware

A SureMark printer that is RS-232 attached has the capability to receive SureMark firmware updates from its attached host system unit. To update the firmware, use the latest drivers from the IBM Retail Store Solutions Web site:
www.ibm.com/solutions/retail/store.

Chapter 2. Communication parameters

RS-232 serial parameter	6	Select color printing	44
RS-232 commands summary by function	6	Set line spacing using minimum units	45
Alphabetized commands summary	10	Set sheet eject length	45
System commands	13	Set horizontal tab positions	46
Verify previous commands completed	13	Set left margin position	46
Status request	13	Set right margin position	47
Reset printer	13	Set relative position.	47
EC/Request/Real-time status request.	14	Set low paper calibration	48
Retrieve Native Mode Status (when printer is in compatibility mode)	14	Align positions	48
Retrieve Native Mode Device ID (when printer is in compatibility mode)	14	Set error recovery function	49
Extended address command-request printer ID	15	Define document wait time	49
Printer ID format	15	Status sent to system	50
Emulation mode for Model 1xR / 2xR	16	Select character for reprinted lines.	50
Emulation of Non-IBM printers.	17	Re-initialize the printer	51
Preset or onetime-set commands	18	Enable or disable the beeper.	51
Memory allocation	18	Enable or disable the feed buttons	52
Double-byte characters	20	Enable or disable upside-down printing	52
Download graphics (logo) commands	20	Select character size for scalable fonts	53
Predefine messages.	22	Fix font matrix	54
Download user-defined characters.	23	Print logo inline	54
Thermal code page	24	Set or cancel strike-through	55
Proportional font	25	Select thermal paper	55
Impact code page	27	Bar code commands	56
User-defined code page mapping	28	Print bar code	56
Request checksum of flash memory sector	29	Print bar code examples	61
Retrieve checksum of each downloaded logo or each stored message	29	Select horizontal size of bar code	61
Flash storage write	30	Select bar code height	61
Erase flash sector	30	Select printing position of human readable information (HRI)	61
Microcode tolerance (MCT) information - loading	31	Select font for HRI	62
Microcode tolerance (MCT) information - request	31	Print PDF417 bar code.	62
Setup commands	35	Select PDF417 ECC (error correction codewords) level.	63
Set print mode	35	Select aspect ratio PDF417 bar code	63
Set or cancel double-wide mode	37	Enable PDF417 truncation	64
Set or cancel double-high mode	37	Print character commands	64
Set or cancel underline mode	38	Print and line feed	64
Set or cancel overline mode	38	Print and line feed	64
Set or cancel invert mode.	38	Print, form feed, and cut the paper (FF)	64
Set or cancel emphasized printing	38	Print and feed paper n lines	65
Select maximum print speed.	39	Print and feed paper using minimum units.	65
Set or cancel unidirectional printing	39	Print graphic messages	65
Set document length for landscape print.	39	Select and print a graphics (logo) command	65
Request document length for landscape print	40	Print predefined graphics (logo) command	67
Set print station	40	Enable watermark printing	68
Select user-defined or resident character sets	41	Print predefined messages	68
Set code page.	41	Check processing commands - 2CR only	69
Set intercharacter spacing for single byte character sets	42	MICR read	69
Set intercharacter spacing for double byte character sets	42	Flip check	71
Set or cancel rotated characters	43	Miscellaneous commands.	71
Set print station parameters	43	Horizontal tab	71
Select 1/8-inch line spacing	43	Backspace for composite characters	71
Select 1/6-inch line spacing	44	Return home (select print head location).	72
		Paper cut/DI eject	73
		Generate drive pulse for cash drawer.	73
		Retrieve the flash storage.	73

Retrieve size of user flash storage	74	Marker command	76
Prepare printer for shut down (S3)	74	Reset line count	77
Asynchronous (real-time) commands	74	Disable line count	77
Real-time requests	74	Hold printing until buffer is released	77
Data buffer management and batch printing	76	Release print buffer.	78

Unless noted otherwise, the communication parameters in this section apply to SureMark printers that attach to a POS system with an RS-232 (EIA232) cable connection.

If you use the RS-485 or USB communications interface, refer to either the SureMark driver documentation in the appropriate IBM book for your operating system (see Table 2) or, when using OPOS drivers, to the *OLE for Retail POS Application Programming Guide*.

Table 2. Driver documentation by operating system

Operating System	IBM Publication
4690 OS Version 1 and Version 2	IBM 4690 OS API Specification for IBM 4610 Printers
DOS	IBM Point-of-Sale Subsystem for DOS Programming Reference
OS/2, Windows NT, Windows 95, and Windows 3.1x	IBM Point-of-Sale Subsystem Programming Reference and User's Guide

The 4690 OS manual is available on the current maintenance diskette for the IBM 4690 operating system. Current versions of all publications are available on the RSS web site.

RS-232 serial parameter

Protocol DTR/DSR mode or XON/XOFF mode

Baud Rate 9600, 19200, 115200

Start 1 bit Data 8 bits Parity None Stop 1 bit

RS-232 commands summary by function

The commands listed in Table 3 are described in detail in the following sections.

Table 3. RS-232 commands organized by function

Description	Command	Page
System Commands		
EC/Request/Real-time status request	DLE ENQ 4 or X'100534' Immediate or X'1B008000' Buffered	14
Enable/disable the feed buttons	ESC c 5 n X'1B6335;n'	52.
Extended address command (request printer ID)	GS SOH or X'1D4901' This is an IMMEDIATE command.	15
Re-initialize the printer	ESC @ or X'1B40'.	51
Reset printer	DLE ENQ @ or X'100540'	13
Status request	ESC v or X'1B76'	13

Table 3. RS-232 commands organized by function (continued)

Description	Command	Page
System Commands		
Verify previous commands completed	X'1B00;80;00'	13
Preset or Onetime-Set Commands		
Download graphics (logo) commands	GS * logo# n1 n2 data or X'1D2A';logo#;n1;n2;data	20
Download user-defined characters	ESC & s n m data or X'1B26;s;n;m;data'	23
Erase flash EPROM sector	ESC # n or X'1B23;n'	30
Flash storage write	ESC ' n1 n2 data or X'1B27;n1;n2;data'	30
Microcode tolerance (MCT) information - loading	ESC M n h l or X'1B4D;n;h;l'	31
Microcode tolerance (MCT) information - request	ESC S n or X'1B53;n'	31
Predefine messages	GS : message# data GS : or X'1D3A; message#;data;'X'1D3A'	22
Send checksum of flash EPROM sector	ESC " n or X'1B22;n'	29
Setup Commands		
Align positions	ESC a n or X'1B61;n'.	48
Define document wait time	ESC f x y or X'1B66;x;y'	49
Enable/disable upside-down printing	ESC { n or X'1B7B;n'	52
Fix font matrix	ESC : n or X'1B3A n'	54
Print logo inline	GS J d n1 n2 data or X'1D4A;d;n1;n2;data'	54
Request document length for landscape print	GS N X'02' Null or X'1D4E0200'	40
Request document length for landscape print	GS c 1 n where n = 2 bytes indicating the length of the document in print motor steps.	"Request document length for landscape print" on page 40
Select 1/8-inch line spacing	ESC 1 or X'1B31'.	43
Select 1/6-inch line spacing	ESC 2 or X'1B32'	44
Select color printing	ESC r n or X'1B72;n'	44
Select character for reprinted lines	ESC + n or X'1B2B;n'	50
Select character size for scalable fonts	GS ! n or X'1D21;n'	53
Select maximum print speed	ESC / n or X'1B2F;n'	39
Select thermal paper	GS; n or X'1D 3B n'	"Select thermal paper" on page 55
Select user-defined or resident character sets	ESC % n or X'1B25;n'	41
Set code page	ESC t n or X'1B74;n'	41

Table 3. RS-232 commands organized by function (continued)

Description	Command	Page
System Commands		
Set document length for landscape print	GS c 1 n where n = 2 bytes indicating the length of the document in print motor steps.	"Set document length for landscape print" on page 39
Set error recovery function	ESC c 4 n or X'1B63;34;n'	49
Set horizontal tab positions	ESC D [n1 n2] NUL NUL or X'1B44[n1 n2]0000'	46
Set intercharacter spacing	ESC SP n or X'1B20;n'	42
Set left margin position	ESC \$ n1 n2 or X'1B24;n1;n2'	46
Set line spacing using minimum units	ESC 3 n or X'1B33;n'	45
Set or cancel double-wide mode	ESC W n or X'1B57;n'	37
Set or cancel double-high mode	ESC h n or X'1B68;n'	37
Set or cancel emphasized printing	ESC G n or X'1B47;n'	38
Set or cancel invert mode	ESC H n or X'1B48;n'	38
Set or cancel overline mode	ESC x'5F' n or X'1B5F;n'	38
Set or cancel rotated character	ESC V n or X'1B56;n'	43
Set or cancel underline mode	ESC - n or X'1B2D;n':	38
Set or cancel unidirectional printing	ESC U n or X'1B55;n'	39
Set print mode	ESC ! n or X'1B21;n'	35
Set print station	ESC c 0 n or X'1B6330;n'	40
Set print station parameters	ESC c 1 n or X'1B6331;n'	43.
Set relative position	ESC \ n1 n2 or X'1B5C;n1;n2'	47
Set right margin position	ESC] n1 n2 or X'1B 5D;n1;n2''	"Set right margin position" on page 47
Set sheet eject length	ESC C n or X'1B43;n'	45
Status sent to system	ESC) n or X'1B29;n'	50
Bar Code Commands		
Enable PDF417 truncation	GS T n or X'1D54;n'	64
Select Aspect Ratio PDF417 bar code	GS S r;c or X'1D53;r;c'	63
Print bar code	GS k n NUL or X'1D6B;n;data;00'	56
Print PDF417 bar code	GS P data NUL or X'1D50;data;00'	62
Select bar code height	GS h n or X'1D68;n'	61
Select font for HRI	GS f n or X'1D66;n'	62
Select horizontal size of bar code	GS w n or X'1D77;n'	61
Select printing position of human-readable information (HRI)	GS H n or X'1D48;n'	61

Table 3. RS-232 commands organized by function (continued)

Description	Command	Page
System Commands		
Select PDF417 ECC Level	GS R <i>n</i> or X'1D52;n1;n2'	63
Print Character Commands		
Print and line feed	LF or X'0A' or CR or X'0D'	64
Print, form feed, and cut the paper (FF)	FF or X'0C'	64
Print and feed paper <i>n</i> lines	ESC d <i>n</i> or X'1B64;n'	65
Print and feed paper using minimum units	ESC J <i>n</i> X'1B4A;n'	65
Print Graphic Messages		
Select and print a graphics (logo) command	ESC * <i>d w h data</i> or X'1B2A;d;w;h;data'	65
Print predefined graphics (logo) command	GS / <i>m logo#</i> or X'1D2F;m;logo#'	67
Print predefined messages	GS ^ <i>message#</i> or X'1D5E;message#'	68.
Miscellaneous Commands		
Retrieve checksum of each downloaded logo or each stored message	ESC <i>n1 n2</i> or X'1B7C <i>n1 n2</i> '	29
Tab to next tab stop	HT or X'09'	71
Return home (select print head location)	ESC < <i>n</i> or 1B3C; <i>n</i>	72
Paper cut/DI eject	ESC i or ESC m -- X'1B69' or X'1B6D'	73
Generate drive pulse for cash drawer	ESC p <i>m n1 n2</i> or X'1B70;m;n1;n2'	73.
Retrieve the flash storage	ESC 4 <i>n1 n2</i> X'1B34;n1;n2'	73
Retrieve size of user flash storage	ESC 4 x '03 FF FF FF' or X'1B3403FFFFFF'	74
Check Processing Commands		
Flip check	ESC 5 or X'1B35'	71
MICR read	ESC I or X'1B49'	69
Asynchronous (Real-Time) Commands		
Real-time requests	DLE ENQ <i>n</i> or X'1005n'	74
Data Buffer Management and Batch Printing		
Reset line count	ESC 6 or X'1B36'	77
Disable line count	ESC 8 <i>n</i> or X'1B38'n	77
Hold printing until buffer is released	ESC 7 or X'1B37'	77
Release print buffer	DLE ENQ 1 X'10;05;31''	78
Page Mode Printing Commands		
Select page mode	ESC L or X'1B4C'	79
Select standard mode	ESC S or X'1B4f'	79
Select printable area	ESC X or X'1B58;x;y;dx;dy'	79
Select printing direction/position	ESC T <i>n</i> or X'1B54;n'	80

Table 3. RS-232 commands organized by function (continued)

Description	Command	Page
System Commands		
Set vertical position	GS \$ <i>y</i> or X'1D24; <i>y</i> '	80
Set relative vertical position	GS \ <i>y</i> or X'1D5C; <i>y</i> '	80
Set right margin position	ESC] <i>n1 n2</i> or X'1B5D; <i>n1;n2</i> "	47
Set left margin position (standard mode), Set absolute print position (page mode)	ESC \$ <i>n1 n2</i> or X'1B24; <i>n1;n2</i> '	81
Set relative horizontal position	ESC <5C>h <i>n1 n2</i> or X'1B5C; <i>n1;n2</i> '	81
Set printing position	GS] <i>x y</i> or X'1D5D; <i>x;y</i> '	82
Print and form feed and cut the paper	FF or X'0C'	82
Print page in page mode	ESC FF or X'1B0C'	83
Clear print data in page mode	CAN or X'18'	83

Alphabetized commands summary

Table 4. Commands in alphabetical order

Description	Command	Page
Align positions	ESC a <i>n</i> or X'1B61; <i>n</i> '	48
Clear print data in page mode	CAN or X'18'	83
Disable line count	ESC 8 <i>n</i> or X'1B38' <i>n</i>	77
Define document wait time	ESC f <i>x y</i> or X'1B66; <i>x;y</i> '	49
Download double-byte characters	485/USB Syntax: X'1B28; <i>s;n;data</i> ' RS232 Syntax: ESC s (<i>n data</i> or X'1B;28; <i>s;n;data</i> "	20
Download graphics (logo) commands	GS * <i>logo# n1 n2 data</i> or X'1D2A; <i>logo#;n1;n2;data</i> '	20
Download user-defined characters	ESC & <i>s n m data</i> or X'1B26; <i>s;n;m;data</i> '	23
Enable PDF417 truncation	GS T <i>n</i> or X'1D54; <i>n</i> '	64
Enable/disable the feed buttons	ESC c 5 <i>n</i> X'1B6335; <i>n</i> '	52.
Enable/disable two-color printing	GS; <i>n</i> or X'1D3B <i>n</i> '	55
Enable/disable upside-down printing	ESC { <i>n</i> or X'1B7B <i>n</i> '	52
Erase flash EPROM sector	ESC # <i>n</i> or X'1B23; <i>n</i> '	30
Extended address command-request printer ID	GS or X'1D4901'	15
Fix font matrix	ESC : <i>n</i> or X'1B3A; <i>n</i> '	54
Flash storage write	ESC ' <i>n1 n2 data</i> or X'1B27; <i>n1;n2;data</i> '	30
Flip check	ESC 5 or X'1B35'	71
Generate drive pulse for cash drawer	ESC p <i>m n1 n2</i> or X'1B70; <i>m;n1;n2</i> '	73
Hold printing until buffer is released	ESC 7 or X'1B37'	77
Impact code page	MCT commands.	27

Table 4. Commands in alphabetical order (continued)

Description	Command	Page
MICR read	ESC I or X'1B49'	69
Microcode tolerance (MCT) information - loading	ESC M <i>n h l</i> or X'1B4D;n;h;l'	31
Microcode tolerance (MCT) information - request	ESC S <i>n</i> or X'1B53;n'	31
Paper cut/DI eject	ESC i or ESC m or X'1B69' or X'1B6D'	73
Predefine messages	GS : <i>message# data</i> GS : or X'1D3A;message#;data;1D3A'	22
Print and feed paper <i>n</i> lines	ESC d <i>n</i> or X'1B64;n'	65
Print and feed paper using minimum units	ESC J <i>n</i> or X'1B4A;n'	65
Print and line feed	LF or X'0A'	64
Print and line feed	CR or X'0D'	64
Print bar code	GS k <i>n</i> NUL or X'1D6B;n;data;00'	56
Print logo inline	GS J <i>d n1 n2 data</i> or X'1D4A;d;n1;n2;data'	54
Print page in page mode	ESC FF or X'1B0C'	83
Print PDF417 bar code	GS P <i>data</i> NUL or X'1D;50;data;00'	62
Print predefined graphics (logo) command	GS / <i>m logo#</i> or X'1D2F;m;logo#'	67
Print predefined messages	GS ^ <i>message#</i> or X'1D5E;message#'	68
Proportional font	ESC & <i>s n m data</i> or X'1B26;s;n;m;data'	25
Real-time requests	DLE ENQ <i>m</i> or X'1005n'	74
Re-initialize the printer	ESC @ or X'1B40'	51
Request document length for landscape print	GS N X'02' Null or X'1D4E;02;00'	40
Reset line count	ESC 6 or X'1B36'	77
Retrieve size of user flash storage	ESC 4 x '03 FF FF FF' or X'1B34;03;FF;FF;FF'	74
Retrieve the flash storage	ESC 4 <i>n1 n2</i> X'1B34;n1;n2'	73
Retrieve checksum of each downloaded logo or each stored message	ESC <i>n1 n2</i> or X'1B7C;n1;n2'	29
Return home (select print head location)	ESC < <i>n</i> or X'1B3C;n'	72
Select and print a graphics (logo) command	ESC * <i>d w h data</i> or X'1B2A;d;w;h;data'	65
Select aspect ratio PDF417 bar code	GS S <i>r;c</i> or X'1D53;r;c'	63
Select bar code height	GS h <i>n</i> or X'1D68;n'	61
Select character for reprinted lines	ESC + <i>n</i> or X'1B2B;n'	50
Select character size for scalable fonts	GS ! <i>n</i> or X'1D21;n'	53
Select color printing	ESC r <i>n</i> or X'1B72;n'	44
Select font for HRI	GS f <i>n</i> or X'1D66;n'	62
Select horizontal size of bar code	GS w <i>n</i> or X'1D77;n'	61
Select page mode	ESC L or X'1B;4C'	79

Table 4. Commands in alphabetical order (continued)

Description	Command	Page
Select PDF417 ECC level	GS R <i>n</i> or X'1D52;n1;n2'	63
Select printable area	ESC X or X'1B58;x;y;dx;dy'	79
Select printing direction/position	ESC T <i>n</i> or X'1B54;n'	80
Select printing position of human-readable information (HRI)	GS H <i>n</i> or X'1D48;n'	61
Select standard mode	ESC S or X'1B4F'	79
Select user-defined or resident character sets	ESC % <i>n</i> or X'1B25;n'	41
Select 1/6-inch line spacing	ESC 2 or X'1B32'	44
Select 1/8-inch line spacing	ESC 1 or X'1B31'	43
Send checksum of flash EPROM sector	ESC " <i>n</i> or X'1B22;n'	29
Select maximum print speed	ESC / <i>n</i> or X'1B2F;n'	39
Set code page	ESC t <i>n</i> or X'1B74;n'	41
Set document length for landscape print	GS c 1 <i>n</i>	39
Set error recovery function	ESC c 4 <i>n</i> or X'1B63;34;n'	49
Set horizontal tab positions	ESC D [<i>n1 n2</i>] NUL NUL or X'1B44[<i>n1n2</i>]0000'	46
Set intercharacter spacing	ESC SP <i>n</i> or X'1B20;n'	42
Set left margin position	ESC \$ <i>n1 n2</i> or X'1B24;n1;n2'	46
Set left margin position (standard mode), Set absolute print position (page mode)	ESC \$ <i>n1 n2</i> or X'1B24;n1;n2'	81
Set line spacing using minimum units	ESC 3 <i>n</i> or X'1B33;n'	45
Set or cancel double-high mode	ESC h <i>n</i> or X'1B68;n'	37
Set or cancel double-wide mode	ESC W <i>n</i> or X'1B57;n'	37
Set or cancel emphasized printing	ESC G <i>n</i> or X'1B47;n'	38
Set or cancel invert mode	ESC H <i>n</i> or X'1B48;n'	38
Set or cancel overline mode	ESC x'5F' <i>n</i> or X'1B5F;n'	38
Set or cancel rotated character	ESC V <i>n</i> or X'1B56;n'	43
Set or cancel underline mode	ESC - <i>n</i> or X'1B2D;n'	38
Set or cancel unidirectional printing	ESC U <i>n</i> or X'1B55;n'	39
Set print mode	ESC ! <i>n</i> or X'1B21;n'	35
Set print station parameters	ESC c 1 <i>n</i> or X'1B63;31;n'	43
Set print station	ESC c 0 <i>n</i> or X'1B63;30;n'	40
Set printing position	GS] <i>x y</i> or X'1D5D;x;y'	82
Set relative horizontal position	ESC <5C>h <i>n1 n2</i> or X'1B5C;n1;n2'	81
Set relative position	ESC \ <i>n1 n2</i> or X'1B5C;n1;n2'	47
Set right margin position	ESC] <i>n1 n2</i> or X'1B5D;n1;n2''	47
Set low paper calibration	GS c 2 or X'1D63;32'	48

Table 4. Commands in alphabetical order (continued)

Description	Command	Page
Set relative vertical position	GS \ <i>y</i> or X'1D5C; <i>y</i> '	80
Set sheet eject length	ESC C <i>n</i> or X'1B43; <i>n</i> '	45
Set vertical position	GS \$ <i>y</i> or X'1D24; <i>y</i> '	80
Status request	ESC v or X'1B76'	13
Status sent to system	ESC) <i>n</i> or X'1B29; <i>n</i> '	50
Tab to next tab stop	HT or X'09'	71
Thermal code page	MCT commands; see Table 8 on page 31.	24
Verify previous commands completed	X'1B00;80;00'	13

System commands

This section describes the system commands.

Verify previous commands completed

Syntax:

X'1B00;80;00'

Purpose:

This command is used to ensure that all commands preceding it have been completed. The application waits for the status return with status byte 5, bit 1 set.

Remarks:

The printer status is returned in status bytes 1–16. Status byte 5, bit 1 is set after this request has been executed. See Chapter 5, “Status information,” on page 89 for more information.

Error Conditions:

None

Status request

Syntax:

ESC v or X'1B76'

Purpose:

The printer status is sent to the system. This command will be processed in the order it was received.

Remarks:

The printer status is returned in status bytes 1–16. See Chapter 5, “Status information,” on page 89 for more information. For RS-232 printers, this command is always buffered and processed in the order it is received.

Error Conditions:

None

Reset printer

Syntax:

DLE ENQ @ or X'100540'

Purpose:

The printer stops if processing a command and begins its reset routine. The print buffer is canceled. All commands are erased. All printer settings go back to default values.

Remarks:

None

Error Conditions:

None

EC/Request/Real-time status request

Syntax:

DLE ENQ 4 or X'100534' Immediate or X'1B008000' Buffered

Purpose:

To send the printer status to the system.

Remarks:

The printer status is returned in status bytes 1–16. Status byte 5 bit is set after the EC request is executed. When used as a buffered command, this command can be used to insure that all commands preceding it have been completed. The application waits for the status to return with Status Bytes 5, bit 1 set. (See Chapter 5, “Status information,” on page 89.)

Error conditions:

None

Retrieve Native Mode Status (when printer is in compatibility mode)

Syntax:

GS N ENG NULL or X'1D;4E;05;00'

Purpose:

To read the native mode status when in compatibility mode.

Remarks:

16 status bytes of data will be sent over the serial following the status bytes. Status byte 5 is set, indicating that there is extra data attached.

Note: Supported on 2xR/1NR printers.

Error conditions:

None

Retrieve Native Mode Device ID (when printer is in compatibility mode)

Syntax:

GS N ENG NULL or X'1D;4E;05;01'

Purpose:

To read out the native mode device ID when in compatibility mode.

Remarks:

Following the 8 compatibility mode status bytes is the native mode device ID status bytes.

Note: Supported on 2xR/1NR printers.

Error conditions:
None

Extended address command-request printer ID

Syntax:
GS | SOH or X'1D4901'

Purpose:
This command returns 15 bytes of printer-specific information following the printer status.

Printer ID format

Table 5. Device Type = 30

Byte 1:	Device type = 30	Reserved
Byte 2:	Device ID	08
Byte 3:	EC – HW version level	Reserved
Byte 4:	EC – Software release level	This level increments after a formal test cycle on the code. (This is the same as Status byte #4)
Byte 5:	EC – Software interim version Level	The level that would increment as fixes were released for test. If a customer had a “pre-released” level, this would be used to track their level.
Byte 6:	CR station width	<ul style="list-style-type: none"> • 72 (0x48): 72 mm print width for 80 mm paper width • 50 (0x32): 50 mm print width for 58 mm paper width
Byte 7:	DI station width 2CR/2NR = 0x50 1NR = 0x00	Portrait station width 80 or 0x50 for 80 mm print width Note: The 4610 is 80.33 mm print width; 474 dots at 150 dpi, and 374 at 120 dpi
Byte 8:	Feature byte detection 2CR / 2NR / 1NR = 0xFF	Bit 0 Two-color printing Bit 1 Two-color enabled Bit 2 CR Cutter Bit 3 Out of Paper detection Bit 4 Low Paper Detection Bit 5 Cover Open Detection Bit 6 Paper jam detection Bit 7 Cutter failure

Table 5. Device Type = 30 (continued)

Byte 9:	Feature byte 2CR = 0x9E 2NR = 0x86 1NR = 0x80	Bit 0 Reserved Bit 1 DI Landscape Station; N/A for Model 1xR Bit 2 DI Station support multipart forms; N/A for Model 1xR Bit 3 MICR reader present; N/A for Models 2NR and 1xR Bit 4 Flipper present; N/A for Models 2NR and 1xR Bit 5 Scanner present; N/A for Models 1xR and 2xR Bit 6 Journal print station – N/A for Models 1xR and 2xR Bit 7 Cash drawer capable. Cannot detect when cash drawer is attached.
Byte 10:	Feature byte	Bit 0 DBCS capable Bit 1 DBCS enabled (character sets downloaded and DBCS mode selected) Bit 2 EJ capable Bit 3 EJ enabled (memory allocated for EJ) Bit 4 Beeper present - N/A for 2CR and 2NR Bit 5 Reserved Bit 6 Reserved Bit 7 Reserved
Byte 11:	Feature byte	Command set version. This is incremented when major printer functions change.
Byte 12:	Feature byte	Reserved
Byte 13:	Feature byte	Reserved
Byte 14:	Feature byte	Reserved
Byte 15:	Feature byte	Reserved

Emulation mode for Model 1xR / 2xR

The emulation mode for Model 1xR/2xR is intended for customers with applications that are hard-coded for their existing SureMark printers.

When in emulation mode, the printer will:

- Respond to the Device ID command and match one of the existing printers.
- Return a status that:
 - Matches the existing printers of 8 status bytes.
 - Fixes the “Status Byte 4” (for RS-232) EC level at 0x61

- Fixes the EC level in the DEVICE ID at 0x61.
- Sets status byte 1 bit 6 (CR cover open) if any of the following errors are detected:
 - CR feed error (status byte 11 bit 0)
 - CR paper out (status byte 8, bit 5)
 - Cutter jam (status byte 11 bit 5)
- Firmware download and erase commands: The firmware will look at the code that is downloaded to verify that the code is 1xR/2xR code before it erases the current code in the printer. If the code is not 1xR/2xR code, the old firmware will not be erased. No error bit will be set.

All DBCS characters must be downloaded at the same time.

Usage variables for system management cannot be read with the same commands as legacy printers. Use the IBM drivers for access to system management.

Physical differences between Models 1xR and 2xR and previous printers:

- The position of the cutter is different.
- Not as much paper needs to be fed to advance the paper above the print head.
- The default for the "0C" command will be less.

The diagnostic package recognizes the printer as being in emulation mode and sends the correct firmware file to the printer for updating.

The printer will be setup in Emulation mode when sent from the factory. Any driver and application that support Models 2xR and 1xR should put the printer into native mode when it is installed. This can also be done using an offline setup procedure.

Emulation of Non-IBM printers

A 1xR printer can be put into EPSON Emulation mode via an Offline setup or via a Software command, MCT #1E, bit 0. See Microcode Tolerance Information -Loading. If the printer is in Epson Emulation mode and you want to run the IBM Diagnostics for POS Systems and Peripherals package against the printer, then you must put the printer into native mode or legacy mode using the printer offline test mode before the diagnostics package is started. Once you have finished running Diagnostics against the printer, you can set the printer back into Epson Emulation mode using the utilities in the diagnostics package or the same function in the printer offline test mode.

- Emulation is only supported in single-byte character set (SBCS) mode can emulate an Epson single-station SBCS printer.
- Emulation mode provides full support for most Epson commands. However, some commands are supported partially and a few commands are not supported at all.
- There will be some differences in the printed output, because of different dot pitches in the print heads and the minimum distance that the paper feed motors can move the paper. These differences will appear when there are a number of printed lines, and the method of aligning the data is different.
- Logos and downloadable characters are supported in emulation mode. However, because the Epson printer prints at 180 dpi and the SureMark prints at 200 dpi, the emulated printout will be smaller.

- In order to implement fixes, new functionality, and other improvements, new releases of printer microcode are routinely published. It is advisable that you run the most recent version firmware on the printer.
- If one line is aligned using spaces and another line is aligned using the relative position commands, the data might appear misaligned. The commands, such as the relative position and margin commands that use the minimum unit of motion values are based on a fraction of an inch, which eliminates the differences in the dot pitch. Tabs and spaces are subject to pitch differences.
- To use one of the 1NR code pages while in EPSON Emulation Mode, store the code page number to MCT #0x81. See "Set code page" on page 41 for additional information.

Preset or onetime-set commands

The SureMark printer has commands to specialize and tune each printer to improve its usability, performance, and uniqueness. This flexibility is provided through the use of flash erasable programmable read-only memory (flash EPROM). Data in this memory device remains valid until it is redefined. This information only needs to be defined once because it remains for the life of the printer or until it is redefined.

To verify that data was previously stored in the printer, the system can request a checksum on data stored in each sector.

The Flash EPROM can be allocated up to 10 sectors. To rewrite information in a sector, you must first erase the sector.

- For logo commands and predefined messages, erasing the sector is necessary only to replace a logo or predefined message number, or when the length of the logo or message exceeds space available in that sector.
- For user flash memory, erasing the sector is necessary only when writing to an address that has already been written to.
- For user-defined thermal and impact characters, new characters can be added if they have the same matrix as characters already in the character set. If new character sets are added, the flash memory does not have to be erased. To replace characters, you must first erase the sector.

Sector Function:

- | | |
|----|---|
| 1 | Download graphics (logo) commands |
| 2 | Predefined messages |
| 3 | Two user-defined impact character sets |
| 4 | User-defined thermal character set: four fixed matrix or 2 proportional |
| 5 | User flash memory |
| 7 | Thermal DBCS character storage |
| 8 | Impact DBCS character storage |
| 9 | Electronic journal storage |
| 10 | User-defined code page mapping |

Memory allocation

The amount of memory allocated to each function is specified by the value stored to its respective MCT location. (See Microcode Tolerance Information - Loading

and Microcode Tolerance Information - Request commands regarding information for adjusting these values.) The MCT value represents the number of 64KB sectors assigned to the respective function.

In Model 2xR/1xR reallocation: To change the memory allocation of any of the character sets (user-defined impact characters, user-defined thermal characters, thermal DBCS character storage, Impact DBCS character storage), ALL memory partitions must be emptied or erased. To change the memory allocation of any of the remaining functions, ALL remaining memory partitions must be emptied/erased. If the memory is not erased, an MCT write error status will be returned.

After the MCT values are written, the new values will not take effect until after a reset. The new memory allocations will start with the user defined character sets (sectors 3 and 4), and then the DBCS (sectors 7 and 8), and then increment upward starting with sector 1. Memory will be allocated until all requests are satisfied, or until all available memory is used.

There is a total of forty-eight 64 KB sectors, for a total of 3.0 MB of FLASH memory to allocate.

Note: The flash EPROM is guaranteed for a minimum life of 100,000 write/erase commands by the flash manufacturer.

Table 6 lists the printer defaults.

Table 6. Printer memory allocation defaults

Function	Default memory allocation	MCT location
User-defined impact characters**	64 KB (0x0001) - 2xR 0 KB - 1xR	0xa0
User-defined thermal characters	64 KB (0x0001)	0xa1
Logos	64 KB (0x0001)	0xa2
Predefined messages	64 KB (0x000a)	0xa3
User memory	128 KB (0x0002)	0xa4
Scan image storage	0 KB (0x0000) for Model 2xR and 1xR	0xa5
Thermal DBCS character storage	1152K (0x0012)	0xa6
Impact DBCS character storage**	567 KB (0x0009)	0xa7
Electronic journal storage Note: For electronic journal storage in the printer, use the drivers provided by IBM. See www.ibm.com/solutions/retail/store .	0KB (0x0000)	0xa8
User defined code page mapping	64 KB	0xa9
**For single station printers, the impact DBCS character storage and the user-defined impact characters storage cannot be addressed: they remain at 0 KB.		

Table 6. Printer memory allocation defaults (continued)

Function	Default memory allocation	MCT location
DBCS Code page Note: As double byte code pages are modified, these allocations could change. See the double-byte information available on the RSS web site: www.ibm.com/solutions/retail/store	Memory allocation required for thermal DBCS (0xa6)	Memory allocation required for impact DBCS (0xa7)** N/A for 1xR In the 1xR this value is fix to 0KB.
Japan - 932	0x0007 (448 KB)	0x00004 (256 KB)
Traditional Chinese - 950	0x000E (960 KB)	0x0007 (448 KB)
Simplified Chinese - 1381	0x0007 (448 KB)	0x0004 (256 KB)
Korean - 949	0x0007 (448 KB)	0x0003 (192 KB)

Double-byte characters

Important

Use the IBM-provided drivers, diagnostics, and utilities to download the DBCS characters to the printer.

Download graphics (logo) commands

Syntax:

GS * logo# n1 n2 data or X'1D2A;logo#;n1;n2;data'

Where:

logo# The logo number being stored

1 <=logo#<=255

n1 One-eighth the number of dots in the horizontal direction (width = $8 \times n1$).

range = 1 to 72 for a thermal logo

range = 1 to 59 for an impact logo

n2 One-eighth the number of dots in the vertical direction (height = $8 \times n2$).

range = 1 to 255 for a thermal logo

range = 1 to 5 for an impact logo

data The data to form the graphics image. The number of data bytes for the image is $n1 \times n2 \times 8$

Purpose:

To store all-points-addressable print messages

Remarks:

A checksum is stored in the printer for each logo downloaded to the printer. See "Retrieve checksum of each downloaded logo or each stored message" on page 29. The checksum can be read by the application to

determine the logos that have been stored in the printer. These messages can be positioned on the page using the commands for setting positions.

Decimal values are shown, but all parameter values (logo number, n1, n2) must be hex values when sent to the printer.

The dot density of these messages is specified when the message is printed. See "Print predefined graphics (logo) command" on page 67.

The total number of data bytes defined for all defined graphics messages depends upon the amount of memory the user has allocated. See "Memory allocation" on page 18.

If the parameters logo#, n1, or n2 are out of range, the command is discarded and its remaining data is processed as print data.

This command should be sent only when the data buffer is empty. See the description of bit 6 in "Erase flash sector" on page 30.

Images for the thermal logo commands will be defined by one-dot-high rows (horizontal slices), and the impact will be defined by eight-dot-high rows (vertical slices).

Note: For a thermal graphic message that is 24 dots high, across the page (n1 = 72, n2 = 3) takes over 2000 bytes of data.

Example: n1 = 2 & n2 = 2

slice #	row #	Bit #	1	2	3	4	5	6	7	8	9	10	11	12	13	14	15	16	Data	bytes	
0 (MSB)	7	7	X	.	X	.	X	.	X	.	X	.	X	.	X	.	X	.	1	2	
1	6	6	X	.	X	.	X	.	X	.	X	.	X	.	X	.	X	.	3	4	
2	5	5	X	.	X	.	X	.	X	.	X	.	X	.	X	.	X	.	5	6	
3	4	4	X	.	X	.	X	.	X	.	X	.	X	.	X	.	X	.	7	8	
4	3	3	X	.	X	.	X	.	X	.	X	.	X	.	X	.	X	.	9	10	
5	2	2	X	.	X	.	X	.	X	.	X	.	X	.	X	.	X	.	11	12	
6	1	1	X	.	X	.	X	.	X	.	X	.	X	.	X	.	X	.	13	14	
7 (MSB)	0	0	X	.	X	.	X	.	X	.	X	.	X	.	X	.	X	.	15	16	
8 (MSB)	7	7	.	X	.	X	.	X	.	X	.	X	.	X	.	X	.	X	.	17	18
9	6	6	.	X	.	X	.	X	.	X	.	X	.	X	.	X	.	X	.	19	20
10	5	5	.	X	.	X	.	X	.	X	.	X	.	X	.	X	.	X	.	21	22
11	4	4	.	X	.	X	.	X	.	X	.	X	.	X	.	X	.	X	.	23	24
12	3	3	.	X	.	X	.	X	.	X	.	X	.	X	.	X	.	X	.	25	26
13	2	2	.	X	.	X	.	X	.	X	.	X	.	X	.	X	.	X	.	27	28
14	1	1	.	X	.	X	.	X	.	X	.	X	.	X	.	X	.	X	.	29	30
15 (LSB)	0	0	.	X	.	X	.	X	.	X	.	X	.	X	.	X	.	X	.	31	32

Bit # → (MSB) 7 6 5 4 3 2 1 0 7 6 5 4 3 2 1 0 (LSB)

Data Byte → 1 2 3 4 5 6 7 8 9 10 11 12 13 14 15 16

Data Byte → 17 18 19 20 21 22 23 24 25 26 27 28 29 30 31 32

For Thermal Graphics - Defined as:

```
X'1D2A010202AAAAAAAAAAAAAAAAAAAAAAAAAAAAAAAAAAAA
55555555555555555555555555555555'
```

For Impact Graphics - Defined as:

```
X'1D2A020202FF00FF00FF00FF00FF00FF00FF00FF00FF00
00FF00FF00FF00FF00FF00FF00FF00FF'
```

Error Conditions:

The error is status byte 3, bit 3: Flash EPROM load error. The following conditions caused this error to occur:

- The command is trying to redefine a logo that was already defined, or
- The allocated memory is full.

Verify the sector was erased before downloading images.

Predefine messages

Syntax:

GS : *message# data* GS : or X'1D3A;message#;data;1D3A'

Where:

message#	The message number being stored 1 to 255
data	All data and commands to be included in this message. No immediate commands can be included in the data.

Purpose:

To store predefined messages. This cuts transmission time. This is where you can store the header and the trailer of receipts, for example.

Remarks:

- After a "GS :." occurs, all incoming commands are stored in the message until another "GS :." occurs.
- "Print predefined graphics (logo) command" on page 67 can be included in this command.
- A Checksum for each downloaded message is stored along with the message. This can be used to verify the correct messages are stored in the printer at printer initialization. See "Retrieve checksum of each downloaded logo or each stored message" on page 29.

Example:

Store a trailer message:

```
X'1D3A01'
'Thank You For Shopping' X'0D'
' At RSD STORE' X'0D'
'Store #1234567' X'0D'
X'1D3A'
```

This would store this message as predefined message 1. See "Print predefined messages" on page 68 for printing this trailer message. Commands for selecting the print station and print characteristics must be included with the stored message.

Limitations:

- "Print predefined graphics (logo) command" on page 67 can be included in this command. Select and print a graphics command cannot be used. See "Print graphic messages" on page 65.
- "Print predefined messages" on page 68 can be included in this command, but can only be nested one message deep.

Example: Store a predefined message ('Jane Doe') at location 3, then issue the following commands:

1. X'1D3A06'
2. 'Welcome to Our Store' X'0D'

3. X'1D5E03' (This prints the message that has been stored at location 3. The message cannot have a X'1D5Exx' in it, because that would be more than one level of nesting.)
4. 'Is Your Cashier Today' X'0D'
5. X'1D3A'

Using the stored message and the above commands, the resulting text will be:

```
Welcome to Our Store
Jane Doe Is Your Cashier Today
```

- These commands *cannot* be included in the predefined message:
 - “Define document wait time” on page 49.
 - “Select character for reprinted lines” on page 50.
 - “Set sheet eject length” on page 45.
 - “Select and print a graphics (logo) command” on page 65.
- This command should be sent only when the data buffer is empty. See the description of bit 6 in “Erase flash sector” on page 30.

Error Conditions:

The error is Status byte 3, bit 3: Flash EPROM load error. The following conditions caused this error to occur:

- The command is trying to redefine a logo that was already defined, or
- The allocated memory is full.

Verify that the sector was erased before downloading images.

Download user-defined characters

Syntax:

ESC & *s n m data* or X'1B26;s;n;m;data'

Where:

- s** The character set being defined
 - 1 User-defined thermal code page 1
 - 2 User-defined thermal code page 2
 - 3 User-defined thermal code page 3
 - 4 User-defined thermal code page 4
 - 5 User-defined impact code page 1
 - 6 User-defined impact code page 2
- n** The beginning ASCII address of the characters being defined.
- m** The ending ASCII address of the characters being defined.
- data** The slice data for the defined characters. Note the number of bytes is determined by which code page is being defined and the character matrix of that code page.

Purpose:

To define a matrix pattern for user-definable code pages stored in flash EPROM.

Remarks:

- After characters are downloaded to the printer, they remain valid until you redefine them. This is true even if power to the printer is removed.

Note: The number of data bytes = $2 \times \text{dot height (20)} = 40$ bytes.

Proportional font

Note: The syntax for the proportional font command is the same command as the "Download user-defined characters" on page 23 with limitations.

EIA-232 Syntax:

ESC & s n m data or X'1B26;s;n;m;data'

Where:

s	The character set being defined
1	User-defined thermal code page 1
3	User-defined thermal code page 3
n	The beginning ASCII address of the characters being defined
m	The ending ASCII address of the characters being defined
data	The height and width of the character, and the matrix pattern for the data. The number of data bytes is $(m-n+1) \times (2+wb \times 32)$. <i>wb</i> is defined in the MCT command.

Purpose:

To download and print proportional fonts (True Type fonts) in the thermal station. Each character in the code page has its own unique width and height. The matrix must be within the following ranges:

Width $8 \leq \text{width} \leq 32$

Height
 $8 \leq \text{width} \leq 32$

Remarks:

- Proportional and standard fonts may be used on the same line. If both types of fonts are used on a line, you would probably use proportional fonts for the description and resident fonts for the amounts.
- For alignment, a command that will allow right and left alignment on the same line may be used. This will allow the user to align a column (decimal point) on the right, and still be left-aligned. (See "Align positions" on page 48).
- Once characters are downloaded to the printer, they remain valid until you redefine them. This is true even if power to the printer is removed.
- Before the characters are defined, the sector of the flash EPROM which stores this data must be erased. (See "Erase flash sector" on page 30).
- You cannot redefine one character only. You must redefine a whole code page.
- If the parameter **s**, **n**, or **m** is out of range, the command is discarded and the remaining data is processed as print data.
- This command should be sent only when the data buffer is empty. See the description of bit 6 in "Erase flash sector" on page 30.
- ASCII characters 0 through 31 are reserved for EIA-232 functions and cannot be defined.
- See "Proportional fonts" on page 97 for suggestions about how to implement proportional fonts.

		row #
0000111100000000	0F00	1
0001111110000000	1F80	2
0011111111000000	3FC0	3
0111000011100000	70E0	4
0110000001100000	6060	5
1100000000110000	C030	6
1100000000110000	C030	7
1100000000110000	C030	8
1100000000110000	C030	9
1100000000110000	C030	10
1100000000110000	C030	11
1100000000110000	C030	12
1111111111100000	FFF0	13
1111111111100000	FFF0	14
1100000000110000	C030	15
1100000000110000	C030	16
1100000000110000	C030	17
1100000000110000	C030	18
1100000000110000	C030	19
1100000000110000	C030	20
1100000000110000	C030	21
1100000000110000	C030	22
0000000000000000	0000	23
0000000000000000	0000	24
0000000000000000	0000	25
0000000000000000	0000	26
0000000000000000	0000	27
0000000000000000	0000	28
0000000000000000	0000	29
0000000000000000	0000	30
0000000000000000	0000	31
0000000000000000	0000	32

Figure 1. Proportional font example

Impact code page

You define the character matrix for each code page with MCT #4 for impact code page 1 and MCT #5 for impact code page 2. See Table 8 on page 31.

If the matrix defines the characters as 9 dots high or less, a print line will be printed in one pass of the print head. When the matrix is defined as greater than 9 dots high, it takes two passes of the print head per print line.

Landscape printing is limited to characters with a height of 9 dots or less. If user-defined characters are to be used in landscape print mode, they must be less than 10 dots high.

The number of data bytes per character loaded is $2 \times \text{character width}$. The total number of data bytes for this command is $2 \times \text{character width} \times (1+m-n)$. Each slice is defined with two bytes; the most significant bit (MSB) of each slice is the bottom of the character.

When defining wire patterns, the same wire does *not* fire in consecutive, primary (P) and secondary (S) positions. (The printer does not check for errors in defining the character.) If the character is defined with dots in consecutive positions only one of the dots is fired.)

Example: 11 half-dots wide (or 5.5 full dots) × 9 high

slice #	1		2		3		4		5		6
Bit #	P	S	P	S	P	S	P	S	P	S	P
7 (MSB)	X
0 (LSB)	X	.	X
1	.	.	.	X	.	.	.	X	.	.	.
2	.	.	X	X	.	.
3	.	X	X	.
4	X	.	X	.	X	.	X	.	X	.	X
5	X	X
6	X	X
7 (MSB)	X	X
Data Byte	2		4		6		8		10		12
Data Byte	1		3		5		7		9		11
	13		15		17		19		21		22

Defined as:

X'1B26034141F000080014000200110000081100020014000800F000'

The above statement defines character X'41' as an 'A'.

Note: The number of data bytes = 2 × dot width (11) = 22 bytes.

Error Conditions:

Flash EPROM load error - Verify the sector was erased before downloading images.

User-defined code page mapping

485/USB Syntax:

X'1B;6a;data'

RS232 Syntax:

ESC j *data* or X'1B;6a;data'

Where:

data 256 bytes of data to fill code page.

Remarks:

Each character is referenced by it's Unicode number. If the Unicode for a character downloaded is NOT part of the resident characters stored in the printer, a space character will be inserted.

Note: The table below only shows a portion of code page 858. If the entire code page 858 were shown, the table would have 128 rows instead of the 9 rows shown below.

Table 7. Unicode positions for code page 858 - 2 bytes for each mapping location

U00000C7	Ã	80h
U00000FC	³	81h
U00000E9	é	82h
U00000E2	â	83h
.....
U00000B9	¹	FBh
U00000B3	³	FCh
U00000B2	²	FDh

Table 7. Unicode positions for code page 858 - 2 bytes for each mapping location (continued)

U00025A0	■	FEh
----------	---	-----

For the Unicode characters supported in the printers please see separate Spread Sheet.

Characters 0x20 through 0x7F are the same as other codepages. Therefore, the amount of Unicode values will be from 0x80 through 0xFF (128 Unicode values, 256 bytes).

Selection of the User Defined code page is ignored if the code page has not been defined. The previous codepage will still be selected.

Error conditions:

Flash EPROM Load Error - verify that this sector was erased before downloading the images. Command Reject - when there is no memory allocated for this function.

Request checksum of flash memory sector

Syntax:

ESC " n or X'1B22;n'

Where:

- n
- 01 Sector 1 - downloaded graphics
- 02 Sector 2 - predefined messages
- 03 Sector 3 - user-defined impact character set
- 04 Sector 4 - user-defined thermal character sets
- 05 Sector 5 - user flash storage
- 06 Thermal double byte character sets
- 07 Impact double byte character sets
- 08 User defined code page mapping

Purpose:

To verify data integrity of the data loaded in the Flash EPROM in the printer.

Retrieve checksum of each downloaded logo or each stored message

ESC | n1 n2 or X'1B7C;n1;n2'

where

n1 = 0x01 for downloaded logos
 = 0x02 for stored messages

n2 The number of the downloaded logo or message that is being queried.

1 <n2<255 or 0x1 < n2 <= 0xFF

Purpose

To verify data integrity of the logos or messages stored in the printer. The printer responds with a 2 byte checksum following the status bytes. If the logo or message is not defined, the checksum will respond as 0x0000.

Status byte 10 bit 2 will be set when this status is returned.

Flash storage write

Syntax:

ESC ' *n1 n2 data* or X'1B27;*n1;n2;data*'

Where:

n1 = number of data bytes to store

n2 = 3-byte address where data bytes are to be stored

Error Conditions:

Flash EPROM load error - Verify the sector was erased before downloading data.

Remarks:

The valid address range depends on the memory allocated to this function. Use "Retrieve size of user flash storage" on page 74 to determine the valid range.

The command is rejected when the address is out of range.

Erase flash sector

Syntax:

ESC # *n* or X'1B23;*n*'

Where:

n

01 downloaded graphics

02 predefined messages

03 user-defined impact character set

04 user-defined thermal character sets

05 flash storage

06 double byte characters

07 reserved

08 Scanned image storage area; n/a for Models 2xR and 1xR

09 Electronic journal storage area

0A User-defined code page mapping

0B - FF
Reserved

Purpose:

To erase the flash EPROM before downloading the data into the printer.

Remarks:

The command should only be sent to the printer when the buffer is empty (status byte 2, bit 6). No other commands should be sent until this command is complete.

Status byte 3, bit 7 (command complete bit) is set to show erasing is finished and the command is complete.

The flash EPROM is guaranteed for a minimum life of 100,000 write/erase commands by the Flash manufacturer.

Microcode tolerance (MCT) information - loading

Syntax:

ESC M *n h l* or X'1B4D;n;h;l'

Where:

- n** Microcode tolerance (MCT) that is being adjusted
- h** The high-order byte of MCT data
- l** The low-order byte of MCT data

Purpose:

The microcode tolerance (MCT) information is used to make adjustments to the printer's microcode. MCT data is nonvolatile data stored in the printer EPROM that is specific to a printer. For example, an MCT parameter can be defined to adjust for mechanical tolerances which cause a print line to not be centered on a document. Another would be for adjusting for the number of motor steps to the first print position on a document. This data remains intact until changed by the user.

Remarks:

Table 8 lists the MCT values by the parameter (*n*). The table includes the default, the minimum, and the maximum values of each MCT.

If you try to set an MCT value out of its defined range, it is set to the closest limit (the minimum or maximum value) or rejected.

Error Conditions:

EPROM load error

Microcode tolerance (MCT) information - request

Syntax:

ESC S *n* or X'1B53;n'

Where:

- n** Microcode tolerance (MCT) information that is being requested

Purpose:

To enable reading MCT information from EEPROM.

Remarks:

- MCT data is sent over the serial line after status bytes. See Table 8 for the values of parameter *n*.
- MCT write command values that are out of range will cause the command to be rejected. (See bit 7 of "Status byte 1" on page 90.)

Table 8. MCT command definitions

DEC	HEX	MCT	Default	Min	Max
1	1	DBCS code page Byte 1: Code page selected Byte 2: Matrix for the impact code page. 0 = 16 x 16 matrix 1 = 9 x 16 matrix	X'FF00'	X'0000'	X'FFFFH'

Table 8. MCT command definitions (continued)

DEC	HEX	MCT	Default	Min	Max
2	2	Matrix of user-defined thermal code page 1 Byte 1: Dot row width Byte 2: Dot row height	X'0A14' (10x20)	X'0810'	X'1020' (16x32)
3	3	Matrix of user-defined thermal code page 2 Byte 1: Dot row width Byte 2: Dot row height	X'0A14' (10x20)	X'0810'	X'1020' (16x32)
4	4	Matrix of user-defined impact code page 1 Byte 1: Half-dot row width Byte 2: Dot row height	X'0707' (07x07)	X'0404'	X'1010' (16x16)
5	5	Matrix of user-defined impact code page 2 Byte 1: Half-dot row width Byte 2: Dot row height	X'0707' (07x07)	X'0404'	X'1010' (16x16)
23	17	Matrix of user-defined thermal code page 3 Byte 1: Dot row width Byte 2: Dot row height	X'0A14' (10x20)	X'0810'	X'1020' (16x32)
24	18	Matrix of user-defined thermal code page 4 Byte 1: Dot row width Byte 2: Dot row height	X'0A14' (10x20)	X'0810'	X'1020' (16x32)

Table 8. MCT command definitions (continued)

DEC	HEX	MCT	Default	Min	Max
30	1E	<p>Mode options</p> <p>Bit 0: (Valid in the 1xR printers)</p> <ul style="list-style-type: none"> • 1 = IBM native mode. • 0 = Set to non-IBM emulation mode. <p>Bits 1–12 Reserved for future use, should be left at 1</p> <p>Bit 13: (DI portrait mode only)</p> <ul style="list-style-type: none"> • 1 = Line feeds not executed until DI ready (non-IBM mode). • 0 = Line feeds are executed without regard for the state of DI ready (IBM mode). <p>Bit 14:</p> <ul style="list-style-type: none"> • 1 = Normal operations (IBM mode). • 0 = Switch order of font A and font B (non-IBM mode). <p>Bit 15:</p> <ul style="list-style-type: none"> • 0 = Disable CR (X'0D') in CR station. No line feeds in DI (non-IBM mode). • 1 = Normal operations. Treat CR (X'0D') the same as line feeds (X'0A'). (IBM mode). 	X'FFFF'	N/A	N/A
33	21	<p>RS232 - Communication. Baud/DataFlow</p> <p>Bit 15</p> <p>1 = DTR/DSR Dataflow 0 = XON/XOFF</p> <p>Bit 14</p> <p>1 = System Unit Flow Control (DTR) Disabled 0 = System Unit Flow Control (DTR) Enabled</p> <p>Bit 13-8 Reserved</p> <p>Bit 7 -0 BAUD Rate: 9600 Baud == xx08h 19200 Baud == xx10h 115200 Baud == xx60h</p>	FF60h on Models 2xR and 1xR		FFFFH
51	33	DBCS Address Vector 1	80FFh	0000H	FFFFH
52	34	DBCS Address Vector 2	0000h	0000H	FFFFH

Table 8. MCT command definitions (continued)

DEC	HEX	MCT	Default	Min	Max
53	35	DBCS Address Vector 3	0000h	0000H	FFFFH
68	44	Power supply capabilities - peak current - mAmps			
96-104	60-68	Reserve for manufacturing / native windows driver			FFFFH
105 - 108	69 – 6E	Printer usage statistics	N/A	N/A	FFFFH
111	6F	Status request options:	N/A	0	FFFFH
		<p>Bit 15: See “Microcode tolerance (MCT) information - request ” on page 31. The status returned when the bit is set to 1, the MCT number is not sent with the MCT data; when the bit is set to 0, the MCT number is sent in byte after MCT data.</p> <p>Bit 14: 1 = compatibility mode with older printers. 0 = Models 2xR and 1xR native mode. The number of Status bytes increases and the format of the Device ID response has changed. See “Extended address command-request printer ID” on page 15.</p> <p>Bit 13: 1 = MICR will be read into the flipper. 0 = MICR reading setup for back-to-back MICR reads. First read into the throat of printer, then read into the flipper.</p> <p>Bit 12: Magnetic noise level: 1 = compatibility mode with older printers. 0 = The data sent from the printer as a result of a MICR read command (1B;49) will include a byte with the amplitude of a noise level. Data would be structured as {Signal Strength; magnetic noise level; MICR read data}</p> <p>Bit 11: MICR Raw data format; 1 = compatibility mode with older printers. 0 = Change the MICR data response to TOAD Format. Symbol Definition “T” TRANSIT “O” ON-US “A” AMOUNT “D” DASH</p> <p>Bits 10: Electronic Journal Options: When all electronic journal sectors are full. 0 = Printer automatically erases the ‘earliest’ session to store the latest data. If there is only one session, the automatic erasing will not work and printer will report an error that all sectors are full. 1 = Printer will report back an error message that all sectors are full. A session must be erased before more EJ data can be stored. Note: For electronic journal storage in the printer, use the drivers provided by IBM. See www.ibm.com/solutions/retail/store.</p> <p>Bits 9- 0: Reserved for future use – should remain at 1.</p>			
129	81	Default Code Page. Upper nibble reserved. Lower nibble default code page. See “Set code page” on page 41 for options.	FF01h	FF00h	FF18h
160	A0	User Defined Impact Character Memory Allocation	0001h - 2xR 0000h - 1xR	0000h	0001h
161	A1	User Defined Thermal Character Memory Allocation	0001h	0000h	0001h
162	A2	User Defined Logos Memory Allocation	0001h	0000h	0030h
163	A3	Predefined messages Memory Allocation	0001h	0000h	0030h
164	A4	User FLASH Storage Memory Allocation	0002h	0000h	0030h
165	A5	Scan Image Storage Memory Allocation	0000h	0000h	0000h
166	A6	Thermal DBCS Character Storage Memory Allocation	000Eh	0000h	002Fh
167	A7	Impact DBCS Character Storage Memory Allocation	0000h - 1xR 0007h - 2xR	0000h	002Fh

Table 8. MCT command definitions (continued)

DEC	HEX	MCT	Default	Min	Max
168	A8	Electronic Journal Storage Memory Allocation	0000h	0000h	0030h
169	A9	User-defined Code Page Mapping	0001h	0000h	0001h

Setup commands

Setup commands change character font, intercharacter spacing, and the target print station.

Set print mode

Syntax:

ESC ! *n* or X'1B;21;*n*'

Where:

n Specifies print characteristics, as shown in Table 9.

Table 9. Print characteristics

Bit Number	Function	Bit=0	Bit=1	Thermal	Impact
(LSB) 0	CPI/font	Char/page	See below	yes	yes
1	Font	Char/page	See below	yes	yes
2	Overline	Cancel	Set	yes	no
3	Emphasized	Cancel	Set	yes	yes
4	Double-high	Cancel	Set	yes	yes
5	Double-wide	Cancel	Set	yes	yes
6	Inverted/DBCS compressed	Cancel	Set	yes	DBCS only
(MSB) 7	Underlined	Cancel	Set	yes	no

Default:

n = 00

Example

To set the print mode to Font B, Emphasized, and Underlined, use the X'1B;21;89' command.

Remarks:

Single byte character sets:

- Table 10 lists the characters to select fonts A, B, or C.

Table 10. Characters that select font A, B, and C

Bit	User defined Thermal	User defined Impact	Resident Thermal	Resident Impact
1 0	Code page 1	Page 1 @ 150 dpi	Font A	Font A
0 0	Code page 2	Page 1 @ 120 dpi	Font B	Font B
1 0	Code page 3	Page 2 @ 150 dpi	Font C	Font A
1 1	Code page 4	Page 2@ 120 dpi	Reserved	Font B

- For thermal printing:
 - Font A = 10 dots (wide) × 20 dots (high) or 1.25 mm × 2.5 mm.

- Font B = 12 dots (wide) × 24 dots (high) or 1.5 mm × 3.0 mm.
- Font C = 8 dots (wide) × 20 dots (high) or 1.0 mm × 2.0 mm.

Invert cannot be used with over-line and underline.

- For impact printing:

- Font A = dot density of 75 half-dots per inch (resident characters = 1.2 mm × 2.0 mm).
- Font B = dot density of 60 half-dots per inch (resident characters = 1.5 mm × 2.0 mm).

Emphasized printing enable and disable, and font A or font B selection must be at the beginning of a print line to be recognized.

User-defined characters greater than 9 dots high cannot be printed double high in TI1/2 printers.

Double-high and emphasized characters are not valid in landscape mode.

- See Chapter 6, “Character fonts,” on page 97, “Download user-defined characters” on page 23, “Set print station” on page 40, and “Select user-defined or resident character sets” on page 41 for related information.

Double byte character sets:

- For thermal printing:

Font size supported = 24 dots (w) × 24 dots (H) or 3.0 mm × 3.0 mm

The number of characters per line is dependent on the intercharacter spacing. For example, if intercharacter spacing is six:

- There are 19 characters/line with 80 mm paper
- There are 13 characters/line with 50 mm paper

- For impact printing:

There are two different font matrixes supported by the printer firmware; however, only one font matrix can be downloaded into the printer at a time:

- 16 dots × 16 full-dots
- 9 dots × 16 half-dots

- Matrix 16x16

Characters can be printed in the following sizes:

Normal

- 150 DPI - 5.4 mm (weight) × 4.0 mm (height)
- 120 DPI - 6.8 mm (weight) × 4.0 mm (height)

Compressed

- 75 DPI - 2.7 mm (weight) × 4.0 mm (height)
- 60 DPI - 3.4 mm (weight) × 4.0 mm (height)

Note: The impact station DPI is the number of 1/2 dots per inch. There are 474 half-dots/line when set for 150 or 75 dpi, and 3799 half-dots/line when set for 120 or 60 DPI.

The size printed is controlled by bit 0 and bit 6:

- Bit 0 can only be changed at the beginning of a print line.

– Bit 6 can change at any time.

Character that are 150 dpi and 75 dip can be mixed on a line. However, characters that are 150 DPI and 120 DPI cannot be mixed on a line. For example, if you have an intercharacter spacing of 3:

– 150 DPI - 13 characters per line (474/35 half-dots per character); n=0x00

– 120 DPI - 10 characters per line (379/35 half-dots per character) n=0x01

– 75 DPI - 24 characters per line (474/19 half-dots per character) n=0x40

– 60 DPI - 19 characters per line (379/19 half-dots per character) n=0x41

• Matrix 9x16

Bit 6 has no effect on this font.

Character are printed in the following sizes:

– 150 DPI - 2.7 mm (weight) x 2.2 (height)

– 120 DPI - 3.4 mm (weight) x 2.2 mm (height)

For example, if the intercharacter spacing is three:

– 150 DPI - 24 characters per line (474/17 half-dots per character)

– 120 DPI - 19 characters per line (379/19 half-dots per character)

Set or cancel double-wide mode

Syntax:

ESC W *n* or X'1B57;n'

Where:

n=00 Cancel double-wide mode

n=01 Set double-wide mode

Default:

n = 00

Set or cancel double-high mode

Syntax:

ESC h *n* or X'1B68;n'

Where:

n=00 Cancel double-high mode

n=01 Set double-high mode

Default:

n = 00

Purpose:

For better print quality with double-high characters in the document station.

Remarks:

See "Set or cancel unidirectional printing " on page 39.

Set or cancel underline mode

Syntax:

ESC - *n* or X'1B2D;*n*'

Where:

n=00 Cancel underline mode

n=01 Set underline mode

Default:

n = 00

Remarks:

This is valid in the Cash Receipt station.

Set or cancel overline mode

Syntax:

ESC x'5F' *n* or X'1B5F;*n*'

Where:

n=00 Cancel overline mode

n=01 Set overline mode

Default:

n = 00

Remarks:

This is valid in the customer receipt station only.

Set or cancel invert mode

Syntax:

ESC H *n* or X'1B48;*n*'

Where:

n=00 Cancel Invert Mode

n=01 Set Invert Mode

Default:

n = 00

Remarks:

This is valid in the customer receipt station only.

Set or cancel emphasized printing

Syntax:

ESC G *n* or X'1B47;*n*'

Where:

n=00 Cancel Emphasized Mode

n=01 Set Emphasized Mode

Default:

n = 00

Remarks:

This must be at the beginning of a print-line in the document portrait station. It is enabled for the entire line.

Select maximum print speed

Syntax:

ESC ? *n* or X'1B2F;*n*'

Where:

n=00 80 lines per second

n=01 52 lines per second

n=02 35 lines per second

Default:

n = 00

Remarks:

- In the cash receipt station, the printing will slow down to the maximum selected speed. This will increase the quality of the printing and lower the current draw from the power supply when printing high-density images, such as dark logos.
- This is the maximum speed being selected, so the dot utilization algorithms can still slow the speed further when necessary.

Set or cancel unidirectional printing

Syntax:

ESC U *n* or X'1B55;*n*'

Where:

n=00 Cancels unidirectional printing

n=01 Sets unidirectional printing

Default:

n = 00

Remarks:

This is valid in the document station in portrait mode only, when there must be two passes of the print head to print one print line.

Example: double-high or emphasized print.

When unidirectional mode is set to double-high characters, it takes three passes of the print head.

In bidirectional mode, printing double-high characters takes only two passes of the print head.

Unidirectional printing takes longer but increases the quality of the print.

Set document length for landscape print

Syntax:

GS c 1 *n*

Where:

n 2 bytes indicating the length of the document in print motor steps.

Remarks

- Document length data is sent in the status after the status bytes.
- Status byte 5, bit 3, is sent to indicate that extra data is attached.

Note: There are 50 motor steps per inch. A 6-inch document = 300 steps. (Use 295 to allow a margin for error; $n=0 \times 127$.) To calculate the number of dots per printed line:

- Under normal operation, the printer measures the length of the document. This command can be used to save transaction time if the document length is known by the application.
- **for 150 DPI** (dots per inch)
 $[(\text{motor_steps} - 75 * 3.12) - 10 = \text{dots per line}]$
- or for a 6-inch document
 $(676 \text{ dots}) / (10 = \text{dots per character}) = 67 \text{ characters per line}$
- **for 120 DPI**
 $[(\text{motor steps} - 75) * 2.5] - 10 = \text{dots per line}$
- or for a 6-inch document
 $(540 \text{ dots}) / (10 = \text{dots per character}) = 54 \text{ characters per line}$

or

Attention: Set the document length a few steps shorter than the actual document. If you set the document length too long the printer will feed the document out of the printer roller and an error will be generated.

Request document length for landscape print

Syntax:

GS N X'02' *NULL* or X'1D4E;02;00'

Purpose

To determine the length of the document in the Landscape Print station

Remarks

- Document length data is sent in after the status bytes.
- Status byte 5, bit 3, is sent to indicate that extra data (beyond status byte 8) is attached.

Set print station

Syntax:

ESC c 0 *n* or X'1B63;30;*n*'

Where:

n Specifies the print station.

Bit # ↓ Station

LSB 0	Electronic journal
1	Cash Receipt Station
2	Document Station - Portrait Mode
3	Document Station - Landscape Mode
4	Reserved
5	Reserved
6	Reserved
7	Reserved

Default:

n = 02

Remarks:

See Chapter 4, "Document handling," on page 85.

The EJ station can be selected along with one of the other stations; however, you cannot select both CR and DI.

Select user-defined or resident character sets

Syntax:

ESC % *n* or X'1B25;*n*'

Where:

n=00 Select resident character sets

n=01 Select user-defined character sets

Default:

n = 00 when printer is in Single Byte Mode

n = 01 when printer is in Double Byte Mode. MCT #0x10 Bit 7

Remarks:

See "Download user-defined characters" on page 23.

Set code page

Syntax:

ESC t *n* or X'1B74;*n*'

Where:

n=00 Code Page 437 - United States

n=01 Code Page 858 - Multilingual

n=02 Code Page 863 - Canadian-French

n=03 Code Page 860 - Portugal

n=04 Code Page 865 - Norway

n=05 Printer's Generic Code Page 1

n=06 Printer's User Defined Code Page Mapping

n=07 Code Page 869 - Greek

n=08 Code Page 857 - Turkish

n=09 Code Page 864 - Arabic

n=0a Code Page 867 - Hebrew (Israel)

n=0b Code Page 852 - Hungarian, Polish, Czech, Romanian, Slovak, Slovenian, Croatian

n=0c Code Page 848 - Ukrainian

n=0d Code Page 866 - Russian (cyrillic)

n=0e Code Page 872 - Bulgarian, Serbian

n=0f Code Page 775 - Lithuanian, Latvian, Estonia

- n=10 Code Page 861 – Icelandic
- n=11 Code Page 1250 – Windows Latin 2
- n=12 Code Page 1251 – Windows Cyrillic
- n=13 Code Page 1252 – Windows Latin 1
- n=14 Code Page 1253 – Windows Greek
- n=15 Code Page 1254 – Windows Turkish
- n=16 Code Page 1255 – Windows Hebrew
- n=17 Code Page 1256 – Windows Arabic
- n=18 Code Page 1257 – Windows Baltic Rim

Default:

n = 01

Remarks:

Changing code pages is valid for resident character sets only. If user-defined character sets are enabled, this command will not do anything. In the DBCS printer, the characters used from each of these code pages will be determined by the DBCS Vector Ranges that are selected. Selection of the User Defined Code Page Mapping (0x06), is ignored if the code page has not been defined. The previous codepage will still be selected

Set intercharacter spacing for single byte character sets

Syntax:

ESC SP *n* or X'1B20;*n*'

Where:

n The number of dot-spaces in the thermal print station or half-dot spaces in the impact print station.

Default:

n = 03

Maximum:

n = 08

Remarks:

If you select double-width printing, the space to the right of each character is doubled.

Set intercharacter spacing for double byte character sets

Syntax:

ESC T *n* or X'1B52;*n*'

Where:

n The number of dot-spaces in the thermal print station or half-dot spaces in the impact print station.

Default:

n = 06

Maximum:

n = 20 hex (32 decimal)

Remarks:

If you select double-width printing, the space to the right of each character is doubled.

Set or cancel rotated characters**Syntax:**

ESC V *n* or X'1B56;*n*'

Where:

n=00 Cancel Rotated Characters

n=01 Set Rotated Character

Default:

n = 00

Remarks:

Rotation is 90 degrees clockwise. This command is supported only in the thermal print station.

Set print station parameters**Syntax:**

ESC c 1 *n* or X'1B63;31;*n*'

Where:

n Specifies the print station.

Bit # ↓ Station

LSB 0 Reserved

1 Customer Receipt Station

2 Document Station - Portrait Mode

3 Document Station - Landscape Mode

4 Reserved

5 Reserved

6 Reserved

7 Reserved

Purpose:

This command is used for setting the line spacing, margins, and tabs.

Remarks:

More than one station can be selected at the same time if the settings are common to all of the selected stations.

Default:

n = 02 (customer receipt station)

Select 1/8-inch line spacing**Syntax:**

ESC 1 or X'1B31'

Remarks:

In the thermal (receipt) station this would set line feeding to 26 steps/line.

In the impact (document - portrait) station this would be set to 6 steps/line.

Note: Spacing in the document - portrait is actually 8.5 lines per inch. Line spacing dimension is approximate. For the impact printer in portrait mode, the actual line spacing must be calculated using 51 steps per inch.

Note: For DI Portrait Printing: Characters greater than 9 dots high (DBCS 16x16 character) takes 2 passes of the print head - with paper fed in-between the lines (4 steps). The actual lines-per-inch will be adjusted. Example if printer is set to 1/8 inch line spacing. The printer will line feed 6 steps in-between each line, and the 4 steps inside of the line. The result is 10 steps/line or 4.8 lines per inch.

In the impact (document - landscape) station this would be set to 16 steps/line.

This command should be sent after "Set print station parameters" on page 43.

Select 1/6-inch line spacing

Syntax:

ESC 2 or X'1B32'

Remarks:

In the thermal (receipt) station this would set line feeding to 34 steps/line.

In the impact (document - portrait) station this would be set to 8 steps/line.

Note: Spacing in the document - portrait is actually 6.375 lines per inch. Line spacing dimension is approximate. For the impact printer in portrait mode, the actual line spacing must be calculated using 51 steps per inch.

In the impact (document - landscape) station this would be set to 21 steps/line.

This command should be sent after "Set print station parameters" on page 43.

Note: For DI Portrait Printing: Characters greater than 9 dots high (DBCS 16x16 character) takes 2 passes of the print head - with paper fed in-between the lines (4 steps). The actual lines-per-inch will be adjusted. Example if printer is set to 1/6 inch line spacing. The printer will line feed 8 steps in-between each line, and the 4 steps inside of the line. The result is 12 steps/line or 4 lines per inch.

Select color printing

Syntax:

ESC r n or X'1B72;n;'

Where:

n =

- 00 Cancel color printing
- 01 Enable full-character color printing
- 02 Enable half-character color printing

Default:

n = 00

Purpose:

To enable half-character or full-character color printing, or to disable color printing.

Remarks:

- You can enable and disable full-character color printing within a print line. This enables you to print one word in a different color.
- This command can be used up to 8 times in a line when full-character color printing is used.
- Half-character color printing is only supported at the beginning of a print line.
- If both bit 1 and bit 0 of *n* are set (n=03), only half-character color printing will be enabled.
- This command is only valid if the Enable Color Printing command is sent first. When color paper is enabled, the printer is limited to printing at 15 LPS when printing 8 LPI.

Limitations:

- This command is only valid if Color Printing is enabled (see “Select thermal paper” on page 55).
- When color paper is enabled, depending on the paper, the printer might be limited to printing at 15 lps when printing 8 lpi.

Set line spacing using minimum units

Syntax:

ESC 3 *n* or X'1B33;*n*'

Where:

n Specifies line-feed steps.

In the customer receipt station, 1 inch = 204 steps and 1 mm = 8 steps. Thermal must be an even number.

In the document portrait station, 1 inch = 51 steps and 1 mm = 2 steps.

In the document landscape station, 1 inch = 127 steps and 1 mm = 5 steps.

This command should be sent after “Set print station parameters” on page 43.

Set sheet eject length

Syntax:

ESC C *n* or X'1B43;*n*'

Where:

n Specifies the number of line feed steps using minimum units moved when a *FF* is sent in the receipt station.

In the document station, an eject will feed until the document has exited the lower document sensors - this length is not used.

Default:

$n = 0x68$ (104 decimal)

Maximum:

255 steps (FF hex)

This value is stored in the printer memory so that it is not lost when the printer is reset.

Set horizontal tab positions

Syntax:

ESC D [*n1 n2*] NUL NUL or X'1B44[*n1n2*]0000'

Where:

n1 The high-order-byte dot offset for the horizontal tab.

n2 The low-order-byte dot offset for the horizontal tab.

Default:

There is a tab every 100 dots.

Remarks:

This command should be sent after "Set print station parameters" on page 43.

Up to 5 tab positions can be stored. All 5 *n1 n2* value pairs can be included in one command. Values must be entered in hex.

A tab is calculated from the left margin position.

Tab values must be in ascending order.

Example: To set 3 tab positions - at the 100, 150 and 300 dot positions:

- X'1B4400640096012C0000'

See "Horizontal tab" on page 71.

Set left margin position

Syntax:

ESC \$ *n1 n2* or X'1B24;*n1;n2*'

Where:

n1 The high-order byte of the dot offset from the beginning of the print line.

n2 The low-order byte of the dot offset from the beginning of the print line.

Default:

$n1 = 0, n2 = 0$

Remarks:

In the customer receipt station, 1 mm = 8 dots.

In the document station, 1 inch = 150 half-dots (75 dots).

n1 and *n2* are hex values. Convert each to decimal. Then, use this formula to get the decimal equivalent: $(n1 \times 256) + n2$.

If the number exceeds the printable area, it is ignored.

The maximum value for the customer receipt station is 576. The maximum value for the document insert station is 474.

In the customer receipt station, this number is rounded back to a factor of 8.

This command should be sent after "Set print station parameters" on page 43.

Set right margin position

Syntax:

ESC] *n1 n2* or X'1B5D;*n1;n2*"

Where

- n1** Is the high order byte of the dot offset from the beginning of the print line.
- n2** Is the low order byte of the dot offset from the beginning of the print line.

Default:

n1 = 0, *n2* = 0

Remarks

In the thermal station, 1 mm = 8 dots.

In the impact station, 1 inch = 150 half-dots (75 dots)

n1, and *n2* are hex values - to get the decimal equivalent = (*n1* × 256) + *n2*

If the number exceeds the printable, it is ignored. If the number + the number set for the left margin does not leave enough room to print a character, these margins are ignored. Maximum value in thermal CR station is 576. Maximum value in Impact DI station is 474. In the CR station, this number is rounded back to a factor of 8.

This command should be sent after "Set print station parameters" on page 43.

Set relative position

Syntax:

ESC <5C>h *n1 n2* or X'1B5C;*n1;n2*'

Where:

- n1** The high-order byte of the dot offset from the left margin.
- n2** The low-order byte of the dot offset from the left margin.

Default:

n1 = 0, *n2* = 0

Remarks:

In the thermal station, 1 mm = 8 dots.

In the impact station, 1 in. = 75-dots (150 half-dots).

n1 and *n2* are hex values. Convert each to decimal, then use this formula to get the decimal equivalent: (*n2* × 256) + *n1*

To move the position to the left, use a negative number.

Example: *To move N dots to the left* ⇒ 65536 – *N*.

If this number plus the left margin exceeds the printable area it is ignored.
See “Set left margin position” on page 46.

In the customer receipt station, this number is rounded back to a factor of 8.

Set low paper calibration

Syntax:

GS c 2 or X'1D63;32'

Purpose:

You must calibrate the printer to accurately recognize the thickness of the paper supply. Calibration can be done using an offline test (see “Summary of the offline test menus (Models 1xR)” on page 108) or using the above command.

Default:

11meter = 0x2AF8.

Note: See “Low paper sensing and calibration” on page 101

Align positions

Syntax:

ESC a n or X'1B61;n'

Where:

- n = 00 Align Left
- n = 01 Align Center
- n = 02 Align Right
- n = 04 Align Column Right

Default:

n = 00

Remarks:

- Values 00, 01, and 02 are only valid at the beginning of a line.
- Tabs are only valid when printing is aligned to the left. If tabs are used when left alignment is not used, results can be unpredictable. (See “Horizontal tab” on page 71.)
- Alignment is relative to the left margin.
- To use the Align Column Right command:
 1. Send the characters that you want to be left aligned.
 2. Send the Align Column Right command.
 3. Send the characters that you want to be right aligned.
 4. Send an end of line command, for example X'0A' or X'0D'.

The printer will return to left aligned after the line is printed.

Limitations for n=04:

- The command is only valid in the cash receipt station.
- The command is ignored if the printer is not left aligned when the command is received.

- If the Align Column Right command is received but the line is filled before an EOL is received, the filled line is treated as an EOL. There are usually a few dot positions available, but not enough for a full character. The column alignment will occur on the few dot positions available.

Set error recovery function

Syntax:

ESC c 4 n or X'1B63;34;n'

Where:

n Selects the function.

Bit # ↓	Function	Bit=0	Bit=1
LSB 0	Reserved	N/A	N/A
1	Reserved	N/A	N/A
2	Release Print Buffer after Error Correction	Release	Hold
32	Automatic retry on a Home Error	Enabled	Not Enabled
4	Hold buffer when waiting for a document	Release	Hold
5	Hold buffer after a flip error	Release	Hold

Default:

n = 00

Remarks:

When set to *not* automatically release the print buffer after error correction (bit #2), the printer does not execute commands until it receives a "Real-time requests" on page 74 command to cancel or release the print buffer.

When automatic retry on a home error is selected, the printer will try to reset the print head to a known location, then reprint the line on which the error occurred. If the printer is unable to reset the print head, operator intervention is needed.

An error will be sent back to the system and the LED will blink.

Define document wait time

Syntax:

ESC f x y or X'1B66;x;y'

Where:

x Time the printer should wait, from receiving a print line for the document station until the document is inserted.

If the document has not been detected by the time the wait time ends, a document error is sent to the system. The system continues to wait for a document to be inserted.

Wait Time = x * 0.5 seconds

y Delay from the time the document is detected until it is *grabbed* by the printer (start of document printing):

- Side insertion - closes the document throat.
- Front insertion - pulls the document into the printer and feeds it to its top of form.

Delay = $y \times 0.1$ seconds

Defaults:

$x = 02$ $y = 03$

Remarks:

If $y = 0$, the printer does not grab the document. The operator must use the document feed button to pull the document into the printer.

If $x = 0$, the printer *never* sends error status if no print data is sent to the document station.

Select character for reprinted lines.

Status sent to system

Syntax:

ESC) n or X'1B29; n '

Where:

n Selects the function.

Bit # ↓	Function	Bit=0	Bit=1
LSB 0	Print Buffer Empty/Full	Yes	No
1	Reserved	Yes	No
2	Front Document Sensor Change	Yes	No
3	Top Document Sensor Change	Yes	No
4	After status byte 6 is incremented or status byte 3, bit 7, is set	Yes	No
5	Cash Draw Sensor Change	Yes	No
6	Key In Use	Yes	No
7	Cover Open	Yes	No

Default:

0x00

Remarks:

Bit 4 can be used in place of the command complete. When the buffer is empty, the system can assume that everything stored in the printer has been completed. To enable these status messages, unsolicited status must be enabled. See "Asynchronous (real-time) commands" on page 74.

Select character for reprinted lines

Syntax:

ESC + n or X'1B2B; n '

Where:

n The ASCII representation of the character printed in the first character position on the print line when recovering from a home error. This occurs in impact print stations only.

Default:

$n = 2A$ hex (This is an asterisk (*) in most code pages.)

Remarks:

The value is stored to printer memory to prevent loss when the printer is reset. The default value after the reset is the value last sent.

Re-initialize the printer

Syntax:

ESC @ or X'1B40'

Purpose:

Re-initialize all printer setting to their default values and reset the impact print head.

Remarks:

Commands in the print buffer are *not* lost when this command is issued. The settings that are re-initialized follow (all numbers are in hex):

Setting	Default Value
Print Mode	00
Print Station Selected	02
User-Defined/Resident Character Sets	00
Code Page	01
Intercharacter Spacing (Single Byte)	03
Intercharacter Spacing (Double Byte)	06
Rotated Characters	00
Station for line spacing	02
Line Spacing (all stations)	Six LPI
Tab Positions	every 100 dots
Left Margin (all stations)	00
Relative Position	00
Align Positions	00
Unidirectional printing	00
Horizontal Size of Bar Code	03
Vertical Size of Bar Code	A2
Position of HR	00
Font for HRI	00
Right Margin (all stations)	00
Error Recovery Color	00

Error Conditions:

None

Enable or disable the beeper

Syntax:

ESC BEL *n1 n2* or X'1B 07 *n1 n2*'

where:

- n1** Enables or disables beeper.
X'00' Disable beeper.
X'01'–X'FE' Timed enable beeper.
X'FF' Enable beeper.
- n2** Sets the beeper volume and tone.
Bits 0–3 The note. Bit 0 is the LSB.
Bits 4–5 The octave.

Bit 6 Reserved.

Bit 7 Volume. 0 = loud, 1 = soft.

Value (Bits 0–3)	Note	Value (Bits 0–3)	Note	Value (Bits 4–5)	Octave
0000–0	C	1000–8	G#	00–0	1
0001–1	C#	1001–9	A	01–1	2
0010–2	D	1010–A	A#	10–2	3
0011–3	D#	1011–B	B	11–3	4
0100–4	E	1100–C	Rest / Silence		
0101–5	F	1101–D	Reserved		
0110–6	F#	1110–E	Reserved		
0111–7	G	1111–F	1 KHz (normal beep)		

Default:

n = X'00'

Purpose:

To enable or disable the beeper.

Remarks:

- Any value other than X'00' or X'FF' is treated as an amount of time that the beeper is to be enabled. The time is calculated as $n1 \times 0.1$ seconds.
- To stop a beep command early, send the Disable Beeper command.
- Timed beeps can be chained together. They can also be downloaded as canned messages.
- Use a value of $n2 = X'2F'$ for the most audible tone.
- Set bits 0–3 to 1100 to put a timed silence in a beep sequence.

Enable or disable the feed buttons

Syntax:

ESC c 5 n or X'1B63;35;n'

Where:

n=0 Enables feed buttons

n=1 Disables feed buttons

Default:

n = 0

Purpose:

To disable the feed buttons while in the middle of a transaction.

Remarks:

If the printer is set to have the buttons disabled, the offline tests will also be disabled.

Enable or disable upside-down printing

This command is only supported in the thermal station.

Syntax:

ESC { n or X'1B 7B n'

Where:

n enables or disables upside-down printing.

X'00' Disable upside-down printing.

X'01' Enable upside-down printing.

Default:

n = X'00'

Purpose:

The print data appears upside down when data is printed normally. This command allows the data to be right-side up as it comes out of the printer.

Remarks:

- When upside-down printing is enabled, the last line of data must be sent to the print first.
- This command is valid only at the beginning of a printer line.

Select character size for scalable fonts

This command is only supported in the thermal station.

Syntax:

GS ! n or X'1D21;n'

Where:

n Defines the height and width of a character. The four least significant bits (LSBs) specify the height and the four most significant bits (MSBs) specify the width of the character. See Table 11.

For example, if n=X'14' the scaled character will be twice the defined width and five times the defined height.

Table 11. Width and height for scalable fonts

Four MSBs (in hex)	Character Width	Four LSBs (in hex)	Character Height
0	As defined	0	As defined
1	2 × defined width	1	2 × defined height
2	3 × defined width	2	3 × defined height
3	4 × defined width	3	4 × defined height
4	5 × defined width	4	5 × defined height
5	6 × defined width	5	6 × defined height
6	7 × defined width	6	7 × defined height
7	8 × defined width	7	8 × defined height

Default:

n = 00

Purpose:

To select the size of a character.

Remarks:

- This command is valid only in the thermal print station.

- Bits 3 and 8 of *n* are ignored.
- The *Set Print Mode* command (see “Set print mode” on page 35) can also select the character height (double high and double wide). The last command that is received is the effective command.
- Underline and overline is not supported when the height is scaled 8x.
- The bar for overline and underline is not magnified in thickness

Fix font matrix

Syntax:

ESC : *n* or X'1B3A;*n*'

Where:

n The character width to which all proportional characters will be adjusted. The range of valid values is $8 \leq n \leq 32$. Use X'00' to disable this command and print proportional characters normally.

Default:

n = 00

Purpose:

To fix the matrix of proportional fonts. This command will be used mostly to align numbers and decimal points.

Remarks:

- This command is valid only on proportional user-defined fonts.
- If the character is larger than the width defined by this command, then the right side of the character will be truncated.
- If the character is smaller than the width defined by this command, then the character will be centered in the space.

Print logo inline

Syntax:

GS J *d n1 n2 data* or X'1D4A;*d;n1;n2;data*'

Where:

d Relative height of the character.
0 Single high
1 Double high
n1 MSB of the logo width.
n2 LSB of the logo width.
data The data to form the graphics image.

Purpose:

To print a small logo inline with characters.

Remarks:

- Thermal station only
- Rotate characters must be disabled
- *n1* and *n2* indicate the number of dots of the bit image in the horizontal direction. The number of dots is calculated as $n1 \times 256 + n2$ (after first converting *n1* and *n2* to decimal).

- The logo is 24 dot rows high. If printed in double-high mode, the logo will be 48 rows high.
- The number of data bytes to form the image is figured by $\{((n1 \times 256 + n2) - 1) / 8 + 1\} \times 24$.
- Like user-defined characters, if the image is only 14 dots wide, the last two dots should be zero to complete the byte. When printed, the image will be only 14 dots wide.

Set or cancel strike-through

Syntax:

ESC; *sn* or X'1B73;*n*'

Where:

n = 00 Cancel strike-through mode.

n = 01 Set strike-through mode.

Default:

n = 00

Remarks:

This is only valid in the Cash Receipt Station.

Select thermal paper

Syntax:

GS; *n* or X'1D3B;*n*'

Where:

n = X'00'

Disable two-color printing.

n = X'01'

Enable color printing using print parameter set 1.

n = X'02'

Enable color printing using print parameter set 2.

n = X'03'

Enable color printing using print parameter set 3.

X'n = 04'–X'FF'

Select the print parameters to be defined.

Purpose:

To enable two-color printing and select the print parameters that are best suited for the paper selected.

Remarks:

- New parameters will be defined as new color papers become available.
- The speed of printing will change depending on the print parameters. When print parameter set 1 is used, the print speed will be 15 lines per second.
- This command setting is saved in nonvolatile memory.

Bar code commands

Bar code commands are valid in the thermal print station only.

Note: For the Models 2xR and 1xR, bar-codes print at a maximum rate of 52 LPS.

Print bar code

Syntax:

GS k n NUL or X'1D6B;n;data;00'

Where: n =

Bar Code

X'00' UPC-A

X'01' UPC-E

X'02' JAN13 (EAN-13)

X'03' JAN8 (EAN-8)

X'04' CODE 39

X'05' ITF

X'06' CODABAR

X'07' CODE 128C

X'08' CODE 93

X'09' CODE 128A, 128B, and 128C

data For $n=00$ through $n=08$, the ASCII representation of the characters to be printed.

For $n=09$, the hexadecimal representation of the characters to be printed. The first byte of data must be the byte-count of the remaining data. The trailing X'00' should not be included for this command.

Remarks:

- Valid at the beginning of a line only.
- This command will increment status byte 6.
- Printing will not start until X'00' is received, or the end of a data packet in RS-485.
- Data after any invalid character for a particular bar code will be discarded. The printer will continue to wait for X'00'.
- If X'00' or an invalid character is received before the required number of data bytes, zeros will be inserted following the data until the required number is reached (for UPC-A, UPC-E, JAN13, and JAN8).
- Excess characters will be discarded.
- A check digit will be generated if one is not supplied for UPC-A, JAN13, and JAN8.
- Check digits will be figured and added for Code 128C and Code 93.
- For UPC-E, the printer will expand the data, generate a check digit and parse the data before generating the bar code (6 or 7 digits are executed). If 7 digits are received and digit 1 is 0, the last 6 digits are used.
If digit 1 is not 0, digit 1 is used and the digit 7 is ignored.

- For CODABAR, a stop and start character is required.
- A leading zero will be added to the data for ITF bar codes if the data received has an odd number of bytes.
- If a bar code width is greater than the paper width, the right of the bar code is truncated, making the bar code unreadable.
- Bar codes will always be printed in black, regardless of color printing settings.

Table 12. Code 128 character set

Value		Code		
Decimal	Hex	Set A	Set B	Set C
0	0	SP	SP	00
1	1	!	!	01
2	2	"	"	02
3	3	#	#	03
4	4	\$	\$	04
5	5	%	%	05
6	6	&	&	06
7	7	'	'	07
8	8	((08
9	9))	09
10	A	*	*	10
11	B	+	+	11
12	C	,	,	12
13	D	-	-	13
14	E	.	.	14
15	F	/	/	15
16	10	0	0	16
17	11	1	1	17
18	12	2	2	18
19	13	3	3	19
20	14	4	4	20
21	15	5	5	21
22	16	6	6	22
23	17	7	7	23
24	18	8	8	24
25	19	9	9	25
26	1A	:	:	26
27	1B	;	;	27
28	1C	<	<	28
29	1D	=	=	29
30	1E	>	>	30
31	1F	?	?	31
32	20	@	@	32
33	21	A	A	33
34	22	B	B	34
35	23	C	C	35
36	24	D	D	36
37	25	E	E	37
38	26	F	F	38

Table 12. Code 128 character set (continued)

Value		Code		
Decimal	Hex	Set A	Set B	Set C
39	27	G	G	39
40	28	H	H	40
41	29	I	I	41
42	2A	J	J	42
43	2B	K	K	43
44	2C	L	L	44
45	2D	M	M	45
46	2E	N	N	46
47	2F	O	O	47
48	30	P	P	48
49	31	Q	Q	49
50	32	R	R	50
51	33	S	S	51
52	34	T	T	52
53	35	U	U	53
54	36	V	V	54
55	37	W	W	55
56	38	X	X	56
57	39	Y	Y	57
58	3A	Z	Z	58
59	3B	[[59
60	3C	\	\	60
61	3D]]	61
62	3E	^	^	62
63	3F	_	_	63
64	40	MUL	'	64
65	41	SOH	a	65
66	42	STX	b	66
67	43	ETX	c	67
68	44	EOT	d	68
69	45	ENO	e	69
70	46	ACK	f	70
71	47	BEL	g	71
72	48	BS	h	72
73	49	HT	i	73
74	4A	LF	j	74
75	4B	VT	k	75
76	4C	FF	l	76
77	4D	CR	m	77

Table 12. Code 128 character set (continued)

Value		Code		
Decimal	Hex	Set A	Set B	Set C
78	4E	SO	n	78
79	4F	SI	o	79
80	50	DLE	p	80
81	51	DC1	q	81
82	52	DC2	r	82
83	53	DC3	s	83
84	54	DC4	t	84
85	55	NAK	u	85
86	56	SYN	v	86
87	57	ETB	w	87
88	58	CAN	x	88
89	59	EM	y	89
90	5A	SUB	z	90
91	5B	ESC	{	91
92	5C	FS		92
93	5D	GS	}	93
94	5E	RS	~	94
95	5F	US	DEL	95
96	60	FNC3	FNC3	96
97	61	FNC2	FNC2	97
98	62	SHIFT	SHIFT	98
99	63	CODE C	CODE C	99
100	64	CODE B	FNC4	CODE B
101	65	FNC4	CODE A	CODE A
102	66	FNC1	FNC1	FNC1
103	67	START CODE A		
104	68	START CODE B		
105	69	START CODE C		

Print bar code examples

Table 13. Print bar code examples

	Command	n =	Data
UPC-A	X'1D6B'	X'00'	X'30 33 31 33 32 33 31 32 30 37 38 00'
UPC-E	X'1D6B'	X'01'	X'34 39 30 36 39 30 00'
JAN 13 (EAN-130	X'1D6B'	X'02'	X'34 39 31 32 33 34 35 36 37 38 39 30 00'
JAN8 (EAN-8)	X'1D6B'	X'03'	34 39 31 32 33 34 35 36 00
CODE 39	X'1D6B'	X'04'	30 31 32 33 34 35 36 37 00
ITF	X'1D6B'	X'05'	31 32 33 34 35 36 37 38 39 30 31 32 00
CODABAR	X'1D6B'	X'06'	42 39 30 2E 2B 3A 2F 24 2D 43 00
CODE 128C	X'1D6B'	X'07'	35 34 35 35 35 36 35 37 35 38 35 39 00
CODE 93	X'1D6B'	X'08'	31 32 33 34 35 36 00
Reserved	X'1D6B'	X'0A - FF'	

Select horizontal size of bar code

Syntax:

GS w n or X'1D77;n'

Where:

n The horizontal magnification of the line width in the bar code, ($2 \leq n \leq 4$).

Default:

n = 03

Note: The last valid value is kept when an invalid value is sent.

Select bar code height

Syntax:

GS h n or X'1D68;n'

Where:

n The dot height of the bar code, ($1 \leq n \leq 255$).

Default:

n = X'A2' (162 decimal)

Select printing position of human readable information (HRI)

Syntax:

GS H n or X'1D48;n'

Where:

n = the print position

n = X'00'
Not Printed

n = X'01'
Above the bar code

n = X'02'
Below the bar code

n = X'03'
Both above and below the bar code.

Default:

n = X'00'

Remarks:

Human readable information is normal text associated with the bar code.

Note: The last valid value is kept when an invalid value is sent.

Select font for HRI

Syntax:

GS f *n* or X'1D66;*n*'

Where: n = the font for the HRI

n = X'00'
Font A

n = X'01'
Font B

Default:

n = X'00'

Remarks:

Only resident character sets are used:

- Font A = 10 dots (W) × 20 dots (H) or 1.25 mm × 2.5 mm
- Font B = 12 dots (W) × 24 dots (H) or 1.5 mm × 3.0 mm

Note: The last valid value is kept when an invalid value is sent.

Print PDF417 bar code

Syntax:

GS P *data* NUL or X'1D50;*data*;00'

Where:

data The ASCII representation of the characters to be printed.

Remarks:

Valid only at the beginning of a line. Printing will not start until a X'00' is received.

This command will increment status byte 6.

The maximum number of characters to be encoded is 1000.

Error Conditions:

If an image cannot be printed, status byte 7, bit 2 will be set. This may happen when the image is too big to print. Try decreasing the ECC level.

Select PDF417 ECC (error correction codewords) level**Syntax:**

GS R *n* or X'1D;52;n1;n2'

Where:

n1 The high-order byte of the ECC level.

n2 The low-order byte of the ECC level.

Default:

n1 = 00

n2 = 15

Range:

$0 \leq n1n2 \leq 400$ decimal (170 hex)

Remarks:

For $0 \leq n1n2 \leq 8$, the ECC level is assumed as that particular security level. The security level determines the number of error correction code words added to the symbol.

Error Correction

Security Level	Codewords
0	0
1	2
2	6
3	14
4	30
5	62
6	126
7	254
8	510

For $9 \leq n1n2 \leq 400$, the ECC level is assumed as a percentage of the codewords in the bar code.

Select aspect ratio PDF417 bar code**Syntax:**

GS S *r;c* or X'1D;53;r;c'

Where:

r The height dimension for the ratio; $1 \leq r \leq 9$.

c The width dimension for the ratio; $1 \leq c \leq 9$.

Default:

r = 1, c = 2

Remarks:

This is not an exact ratio. The image will get as close as possible to the ratio. However, the maximum width of an image is 12 columns and the maximum height is 90 rows.

Enable PDF417 truncation

Syntax:

GS T *n* or X'1D;54;*n*'

Where:

n Whether to enable truncation
0 Disable truncation.
1 Enable truncation.

Default:

n = 0

Remarks:

Truncated PDF generates a symbol with the right row indicator and stop pattern replaced by a single width bar. There is a slight degradation in decode performance if truncation is enabled, which allows more data to fit in the image width.

Print character commands

These commands should be sent after ASCII data is sent to the printer and is being held in the print buffer. Any of these commands will increment the line count by 1. (See "Status byte 6" on page 91 and "Reset line count" on page 77.)

Print and line feed

Syntax:

LF or X'0A'

Purpose:

Prints data in the print buffer and feeds the paper by a preset amount.

Print and line feed

Syntax:

CR or X'0D'

Purpose:

Prints data in the print buffer and feeds the paper by a preset amount.

Remarks:

For applications that send both this command and LF (print and line feed command), and when only one line feed is required, the printer can be set to ignore this command. See MCT #30 (0x1e) in Table 8 on page 31. The default is a line feed.

Print, form feed, and cut the paper (FF)

Syntax:

FF or X'0C'

Purpose:

Prints data in the print buffer and feeds the paper in the customer receipt

station or document insert station by a preset amount, until the document exits the feed rollers. If a cutter is available at the station (CR station only), it cuts the paper.

Print and feed paper *n* lines

Syntax:

ESC d *n* or X'1B64;*n*'

Where:

n Specifies the number of line-feeds.

Purpose:

Prints data in the print buffer and feeds the paper by the amount specified in this command.

Print and feed paper using minimum units

Syntax:

ESC J *n* or X'1B4A;*n*'

Where:

n Specifies the line feed steps.

In the receipt station: 1 in. = 204 steps (1 mm = 8 steps).

In the document portrait station: 1 in. = 51 steps (1 mm = 2 steps).

In the document landscape station: 1 in. = 127 steps (1 mm = 5 steps).

Note: Line spacing dimension is approximate. For the impact printer in portrait mode, the actual line spacing must be calculated using 51 steps per inch.

Purpose:

Prints data in the print buffer and feeds the paper by the amount specified in this command.

Print graphic messages

Select and print a graphics (logo) command

This command can be used to print signature captures at the printer.

1. Capture the signature as a bitmap.
2. Convert the bitmap to a series of graphics (logo) messages.
3. Hold the buffer.
4. Send the graphics messages to the printer.
5. Release the buffer.

Syntax:

ESC * *d w h data* or X'1B2A;*d;w;h;data*'

Where:

d Dot density.

00 Normal Print - 200 dpi in the receipt station, 150 dpi in the document station.

Note: In the document station, this takes three passes of the print head for a logo that is 8 dots high.

01 Double wide - 100 dpi in the receipt station, 75 dpi in the document station.

Note: In the document station, this takes one pass of the print head for a logo that is 8 dots high.

02 Double wide and high - 100 dpi in the receipt station, 75 dpi in the document station. Every dot row in the vertical direction will be printed twice.

w One-eighth the number of dots in the horizontal direction, (width = $8 \times w$)

range = 1 to 72 for a thermal logo.

range = 1 to 59 for an impact logo.

In the receipt station, 1 = 8 dots = 1 mm.

In the document station, 6 = 48 dots = 1 inch.

h One-eighth the number of dots in the vertical direction, (height = $8 \times h$).

range = 1 to 255 for a thermal logo.

range = 1 to 5 for an impact logo.

data The data to form the graphics image.

The number of data bytes must be less than *64K* or $(h \times w) \times 8 < 64K$. To print graphics greater than 64K, see "Download graphics (logo) commands" on page 20 for an example of the data.

Purpose:

To print all-points-addressable print messages.

Remarks:

The margin will be ignored if this causes the logo to overrun the line length.

These messages can be positioned on the page using the commands for setting positions.

Not supported in document landscape mode.

To print graphics on the printer when the data is greater:

1. Hold the buffer.
2. Send all the data.
3. Release the buffer.

Note: When the buffer is held, care must be taken to avoid exceeding the capacity of the printer memory.

The left margin will be rounded down to a factor of 8. For example, if the margin = 74, the logo starts at 72.

Retries are not attempted on print errors.

Valid at the beginning of the line only.

When printing in the document station, a line feed command must be sent to advance the paper past the last line of the logo.

If the parameter *d*, *w*, or *h* is out of the defined range for this command, the command is discarded and the remaining data is processed as print data.

This command will increment status byte 6.

If this message is printed on a regular basis, consider downloading it to save communication time. (See "Download graphics (logo) commands" on page 20.)

The data buffer can be used for signature capture.

Print predefined graphics (logo) command

Syntax:

GS / *m* logo# or X'1D2F;*m*;logo#'

Where:

m The dot density:

00 Normal Print - 200 dpi in the receipt station, 150 dpi in the document station.

Note: In the document station, this takes three passes of the print head for a logo that is 8 dots high.

01 Double wide - 100 dpi in the receipt station, 75 dpi in the document station.

Note: In the document station, this takes one pass of the print head for a logo that is 8 dots high.

02 Double wide and high - 100 dpi in the receipt station, 75 dpi in the document station. Every dot row in the vertical direction will be printed twice.

logo # The number associated with the logo that is stored.

- range = 1 to 40 for all models
- range = 1 to 255 for Models 2CR

Purpose:

To print predefined all-points-addressable print messages.

Remarks:

The margin is ignored if it causes the logo to overrun the line length. Printing this message in the document station at 150 dpi will take three passes of the print head.

These messages can be positioned on the page using the commands for setting positions.

Valid at the beginning of the line only.

This command is not valid in landscape mode.

This command will increment status byte 6.

Retries will not be attempted on print errors.

In the document portrait station, a line-feed command must be sent to advance the paper past the last line of the logo.

See "Download graphics (logo) commands" on page 20.

Enable watermark printing

Syntax:

GS 2B *logo dot offset alignment* or X'1D2B;'logo;dot offset;alignment

Where:

logo Is the number of the stored logo that will be used as the WaterMark
(0x01 <= 0xFF)

dot offset

Is the number of millimeters (8 dot rows = 1 mm) offset between each WaterMark (0x00 <= 0xFF)

alignment/density

Is the alignment and density of the mark

x0 Align Left

x1 Align Center

x2 Align Right

x3 Roll Right (Left -> Center -> Right -> Left -> ...)

x4 Roll Left (Right -> Center -> Left -> Right -> ...)

x5 Zig-Zag (Left -> Center -> Right -> Center -> Left -> ...)

0x Normal Print - 200 DPI in the thermal (receipt) station

1x Double Wide - 100 DPI in the thermal (receipt) station

2x Double High - 100 DPI in the thermal (receipt) station

3x Double Wide and High - 100 DPI in the thermal (receipt) station

Remarks:

Valid only in the Thermal Station. 1 cm = 80 dots.

Limitations:

You cannot use both page mode printing and watermark printing at the same time. The speed of printing depends on the dot density of the watermark. The logo downloaded should be made with a low dot density. This command is support with firmware version 08.00 and greater. When printing line by line the printer will buffer the line that overlaps with the watermark region. Watermark is temporarily disabled when printing barcodes or logos.

Print predefined messages

Syntax:

GS ^ *message#* or X'1D5E;message#'

Where:

message#

The number associated with the stored predefined message.

- range = 1 to 25 for all models

Purpose:

To print predefined print messages.

Remarks:

Valid at the beginning of the line only.

Retries will not be attempted on print errors.

Attention: Stored commands can increment status byte 6. See "Predefine messages" on page 22.

Check processing commands - 2CR only

This printer can process the check entirely without taking it from the printer. It can read the magnetic ink character (MICR) line, frank the back of the check, and flip the check to print the face of the check.

Note: To print the face of the check, select the document station in landscape mode as the print station.

MICR read

Syntax:

ESC I or X'1B;49'

Purpose:



To read account information from the magnetic ink character line on customers' checks.







Remarks:

- Checks should be inserted upside-down from the front and against the right wall of the printer. The check can be, but does not have to be, registered in the printer before this command is given. The check will be fed forward, until the bottom sensor is uncovered, then fed back for the MICR reader reading. After the reading is complete, the check is fed to the first print position.
- If the printer is unable to read any character on the first try, the check will be fed forward and back for a second try. Complete status will then be sent to the terminal - if the character was still not read it will be identified by a Hex 3F (ASCII "?").

Note: Checks with magnetic ink printing within 1.2 inches of the right edge of the check will not be read correctly. This occurs when the amount field is printed on the check.

- The MICR read command increments the line count (status byte 6).
- At the completion of this command, the MICR information will be sent over the serial I/O following the normal status bytes.

Character	Description	ASCII representation	Hex value	TOAD representation
			Bit 13 = 1	Bit 13 = 0
MICR data representation - default				
0-9	Numerical data	0-39	X'30-9'	Same as ASCII representation and Hex value.
	Blank	3F	X'20'	
	Unreadable Character	?	X'3F'	
E13-B - Special characters				
	Transit	T	X'54'	T X'54'
	On Us	A	X'4F'	O X'4F'
	Amount	\$	X'41'	A X'41'

Character	Description	ASCII representation	Hex value	TOAD representation
	Dash	-	Bit 13 = 1 X'44'	Bit 13 = 0 D X'44'
CMC7 - Special characters				
	Special character 1	a	X'61'	
	Special character 2	b	X'62'	
	Special character 3	c	X'63'	Same as ASCII representation and Hex value.
	Special character 4	d	X'64'	
	Special character 5	e	X'65'	

- For E13B checks, the 1st byte of additional data is the signal level of the check. This level represents a percentage of difference that this check is from a nominal check. Nominal checks will have a signal level of 100 (64 hex).
- For CMC7 checks, the additional byte of data will always read 100 (64 hex). In this case, the signal level has no meaning.

Response options

- Dependant upon your options, data is presented as {signal strength; magnetic noise level; MICR read data}.
- Depending upon the setting of MCT 0x6f, bit 10, the second byte of additional data will either be the characters read off the check (up to a maximum of 67 characters) *or* the magnetic noise level (on a scale of 0-100).
 - The default setting is the characters read off the check. If the user enables reading the magnetic noise level, this level will be in the 2nd byte of additional data and the characters read off the check will follow.
 - The characters are read from left to right. The MICR information will be represented as ASCII characters.
- Bit 11: MICR raw data format
 - 1 = Compatibility mode with older printers
 - 0 = Change the MICR data response to TOAD (Transit, On-US, Amount, Dash)
- Bit 12: Magnetic noise level
 - 1 = Compatibility mode with older printers {Signal strength; MICR read data}
 - 0 = The data sent from the printer as a result of a MICR read command (1B;49) will include a byte with the amplitude of a noise level. Data would be structured as {signal strength; magnetic noise level; MICR read data}
- Bit 13:
 - 1 = MICR will be read into the flipper.
 - 0 = MICR reading setup for back-to-back MICR reads. First read into the throat of the printer, then read into the flipper.

Error Conditions:

Document feed error (status byte 7). This bit is set if the inserted check is too long. The maximum check length is 10 inches. The error is also set if the check does not clear the document sensor when expected.

Magnetic noise present (status byte 8, bit 6). Set when MICR read shows random noise count ≥ 100 decimal or periodic noise > 0 . If set to a "1", this value will be in the status message when status byte 5, bit 2 = "1" otherwise it will be a "0" in other status messages. Magnetic noise might be due to a fan or CRT and will affect the accuracy of the MICR reading.

This command is ignored on 2NR printers (without the MICR capability).

Flip check

Syntax:

ESC 5 or X'1B35'

Purpose:

To flip the check after a MICR read. This will allow the face of the check to be printed.

Remarks:

- For faster check processing, set the print station to the document landscape before sending the flip command. Then, the check can print as it leaves the flip mechanism.
- This command increments the line count (status byte 6).

Error Conditions:

Document feed error (status byte 7). This bit is set if the inserted check is too long. The maximum check length is 10 inches. The error is also set if the check does not clear the document sensor when expected.

Miscellaneous commands

Horizontal tab

Syntax:

HT or X'09'

Purpose:

Moves the print position to the next tab stop.

Remarks:

See "Set horizontal tab positions" on page 46.

Tabs are valid when printing is aligned to the left only. If the tabs are used when alignment is not left, results can be unpredictable. (See "Align positions" on page 48.)

Backspace for composite characters

Syntax:

X'08"

Purpose:

To move the print position to the beginning of the last character.

Remarks:

This is only supported on 2xR/1xR printers. It is intended for use with languages that require "composite characters".

Example. Send x`61; 08; 87; 08; 98' to get the composite character below.

0x61	0x87	0x98	To get this character send
.....	...@@...@@.@@...@@.
.....	..@@@@.@@.@@@@.@@.
.....	.@@...@@@.@@...@@@.
.....	.@@...@@.@@...@@.
.....
.@@@@@@@@.@@@@@@@@.
.@@@@@@@@.@@@@@@@@.
.....@@@@@@
.....@@@@
..@@@@@@@@@@@@@@@@
.@@@@@@@@@@@@@@@@
@@@...@@@	@@@...@@@
@@...@@	@@...@@
@@...@@	@@...@@
@@@...@@@	@@@...@@@
.@@@@@@@@@@@@@@@@
..@@@@@@@@.@@@@@@@@.
.....
.....@@...@@.	..@@...@@.
.....@@...@@.	..@@...@@.

Figure 2. Composite Characters

Return home (select print head location)

Syntax:

ESC < n or X'1B;3C;n'

Where:

- n** The print-head position:
 - 00** Document Home Position
 - 01** Open Document Throat Position
 - 02** Reserved
 - 03** Left Home Position
 - 04** Re-find Document Home position. This can be used to recover from a home error.
 - 05** Register Document
 - Close throat if open and document present
 - Advance paper forward to first position if not open
 - 06** Re-register the document if a document is in the printer; brings it back to the first print position on the document.

Remarks:

Only valid at the beginning of the line. Only valid for impact print stations.

Purpose:

To move the print head to the desired location.

Remarks:

Valid at the beginning of the line only. Valid in impact print stations only.

Paper cut/DI eject

Syntax:

ESC i or ESC m or X'1B;69 or 1B;6D'

Purpose:

To cut the paper in the customer receipt station, or eject the document in the document insert station.

Remarks:

- This command is the equivalent of a form feed (0C) in the document insert station but does not feed the customer receipt in the CR station.
- ESC i or X'1B69' *does not* increment status byte 6.
- ESC m or X'1B6D' *does* increment status byte 6.

Generate drive pulse for cash drawer

Syntax:

ESC p m n1 n2 or X'1B;70;m;n1;n2'

Where:

- m** The cash drawer number - 0 or 1.
- n1** Pulse width on time = (n1 × 2) milliseconds.
- n2** Pulse width off time = (n2 × 2) milliseconds.

Purpose:

To open one of the cash drawers attached to the printer.

Remarks:

Printing will be suspended while a cash drawer is being opened.

Retrieve the flash storage

Syntax:

ESC 4 n1 n2 or X'1B;34;n1;n2'

Where:

- n1** One-byte count of the bytes to be returned
- n2** Three-byte address of the first byte to be returned

Purpose:

Retrieve data from user flash storage.

Remarks:

One byte will be returned if a byte count of X'00' is specified.

In many RS-485 printers, the number of bytes retrieved should be kept under 200 to ensure that the system's receive buffer is not overrun.

The valid address range for each SureMark depends on the model number and which memory option, if any, is installed. Use “Retrieve size of user flash storage” to determine the valid address range for your printer.

Retrieve size of user flash storage

Syntax:

ESC 4 x '08 FF FF FF' or X'1B;34;08;FF;FF;FF'

Purpose:

Retrieve the size of the user flash storage in the printer.

Remarks:

The size of the user flash storage will be returned in 8 bytes after the printer status bytes. The data will be in the form of ASCII decimal data.

Prepare printer for shut down (S3)

Syntax:

ESC g or X'1B;67'

Purpose:

Prepares the printer to shut down.

Remarks:

The printer firmware tracks many things in internal memory, including when to trigger low paper parameters and user statistics. These variables must be stored in nonvolatile memory before the printer loses power to keep accurate count of these statistics. When either the ESC g or a reset command is sent to the printer, the printer will store all internal variables into the flash memory. This should be sent to the printer by the system unit before it enters S3 mode, where power is removed for I/O. When the printer powers on (IPLs), a small amount of paper is fed (1/3 of an inch). If ESC g is sent before the printer powers off, the paper will not feed when the printer powers on.

Note: The ESC g command is only supported on the 2xR/1NR printers after the 0C.xx release of the code. It is not supported on legacy printers.

Asynchronous (real-time) commands

These commands are processed as soon as they are received. They do not go into the printer buffer.

Note: These commands are not recognized when they occur in the middle of another command. For example, sending this command after the second byte of a 3-byte command, as in ESC J n.

Real-time requests

Syntax:

DLE ENQ *m* or X'1005:n'

Where:

m Specifies the ASCII command character

n - Specifies the hexadecimal command character

n	Description
31	Release print buffer
32	Cancel print buffer
33	Undefined
34	EC request; send status
35	Undefined
36	Undefined
37	Undefined
38	Undefined
40	Reset printer
41	Enable unsolicited status
42	Disable unsolicited status
43	Disable transparent XON/XOFF

m	n	Description
1	31	Release the print buffer for printing. This should be sent after an error has occurred and the print buffer is held. If an error occurred during the transaction that was being held, the printer sends back the line number with the error and the error status. The system can then decide to cancel or continue printing after the error is corrected. The system uses this command to continue printing after the error is corrected.
2	32	Cancel print buffer. This clears the print buffer of all data. In RS-232 (EIA-232) mode, the user must wait for buffer empty status (status byte 2, bit 6) before sending any more commands. Note: A status message is returned immediately after execution of this command.
3	33	Undefined.
4	34	EC request - transmit printer status. Sends the printer's status to the system. This command does not go into the printer's data buffer but is processed immediately. The printer status is returned in status bytes 1–16. See Chapter 5, "Status information," on page 89 for more information. Status byte 5, bit 1, will be set after the EC request has been executed.
5-8	35-38	Undefined
@	40	Reset the printer. The printer stops what it is doing and goes through its reset routine. The print buffer is canceled and all commands erased. All printer settings go back to default values.

m	n	Description
A	41	Enable unsolicited status. Note: A status message is returned immediately after execution of this command. To enable these status messages, the Status Sent to System setup command must be enabled. See "Status sent to system" on page 50.
B	42	Disable unsolicited status
C	43	Disable transparent XON/XOFF

Purpose:

To process a command immediately.

Remarks:

Either the *Release print buffer* or the *Cancel print buffer* command must be used when the print buffer is held. If the printer is set to hold on error then one of these commands must be used when the error condition is cleared.

After the printer resets, it defaults to *not* sending status unless requested. If an error occurs, the printer appears hung, unless a status is requested. If unsolicited status is enabled, the printer sends the error to the system as soon as it occurs.

Note: If transparent XON/OFF is disabled, X'10', X'11', and X'13' can be imbedded in returned status and data. To re-enable the printer, the printer must be reset.

Data buffer management and batch printing

Marker command

Syntax

ESC = marker or X'1B 3D' marker'

Where:

marker = 1 byte marker: 0x00 and 0x01 markers are reserved.

Purpose

To allow the driver to monitor how much of the data in the printer's buffer has executed. The EC Level command returns status with the EC bit set. If you want to know when a specific command has finished execution, a buffered EC level request could be sent following the command. When status is returned with the EC level bit set, then the previous command has been completed.

Remarks:

The marker will be sent as status byte #4 in place of the EC level of the code, and Status Byte 9, bit #1 will be set to indicate that the EC level has been replaced by the marker for this status. The status with the marker will be sent when all commands received before it has been processed. If only a partial line is sent to the printer (characters without a line feed command), the marker will be sent before the line gets printed.

Example:

```
LINE 1 FGHIJKLMNOPQRSTUVWXYZ1234567890x'0a'
LINE 2 FGHIJKLMNOPQRSTUVWXYZ1234567890x'0a'
LINE 3 FGHIJKLMNOPQRSTUVWXYZ1234567890x'0a'
```

```
0x'1B3D04'  
LINE 4 FGHIJKLMNOPQRSTUVWXYZ1234567890x'0a'  
LINE 5 FGHIJKLMNOPQRSTUVWXYZ1234567890x'0a'  
LINE 6 FGHIJKLMNOPQRSTUVWXYZ1234567890x'0a'  
LINE 7 FGHIJKLMNOPQRSTUVWXYZ1234567890x'0a'  
LINE 8 FGHIJKLMNOPQRSTUVWXYZ1234567890x'0a'  
0x'1B3D05'
```

- After the first three lines, the printer will transmit back status with the normal printer status: Status Byte 4 = x'04'.
- After the 8th line, the printer will send back status with Status Byte 4 = 0x05.

Reset line count

Syntax:

ESC 6 or X'1B36'

Purpose:

Resetting the line count lets the system track the print line where an error occurs.

Remarks:

The line count is incremented at every print command. The count is sent in every status message to the system. The count can go to 256 (X'FF'), when it rolls back to 0. (See "Print character commands" on page 64.)

Disable line count

Syntax:

ESC 8 *n* or X'1B;38'*n*

Where

- *n* = 1, disable line count
- *n* = 0, enable line count

Purpose:

To temporarily not increment the line count. This can be used when printing predefined messages, if the number of lines embedded in the message is unknown.

Hold printing until buffer is released

Syntax:

ESC 7 or X'1B37'

Purpose:

If the system cannot send data to the printer at a speed needed to keep the printer in constant motion, it can hold the printer queue until it sends all data lines for a transaction.

Remarks:

The printer must be printing one line while processing the next line. If the printer is unable to completely process a line, the print speed reduces to half.

The line count is reset when the buffer is held.

Release print buffer

Syntax:

DLE ENQ 1 X'10;05;31"

Purpose:

To release the print buffer for printing

Remarks:

If an error occurs during the transaction that was being held, the printer will send back the line number it occurred on with the error status. The system can then decide to cancel or continue the printing when the error is corrected. The command will continue the printing after the error is fixed.

Chapter 3. Page mode printing commands

This section describes the page mode commands.

Select page mode

Syntax:

ESC L or X'1B;4C'

Remarks:

- Enables page mode printing.
 - Supported on thermal station only.
 - Starting position is set by *Set printable area* X'1B;57.' and *Set print direction* X'1B;54.' commands.
 - Intercharacter spacing X'1B;20;n' and line spacing X'1B;31', X'1B;32', X'1B;33' commands are set independently for page mode and standard mode.
 - The following commands are allowed:
 - Rotate characters
 - Set alignment
 - Set/Clear upside-down
 - Set margins
-

Select standard mode

Syntax:

ESC O or X'1B;4f'

Remarks:

- This command is effective in page mode only.
 - Data buffered in page mode is cleared.
 - This command sets the print position to the beginning of the line.
-

Select printable area

Syntax:

ESC X or X'1B;58;x;y;dx;dy'

Where:

- *x, y*
 - Two-byte horizontal and vertical starting position (in dots)
- *dx, dy*
 - Two-byte horizontal and vertical printing area (in dots)

Remarks:

- When sent in standard mode, this command sets the printable area for page mode, but has no effect on standard mode printing.
- If the starting position (*x, y*) is outside the maximum range, the entire command is ignored.

- If the printing area is defined outside the maximum page size, the printing area is limited to the page size.
- Maximum page size is 576 dots in the horizontal direction, and 800 dots in the vertical direction (except Models Tx8 and Tx9, which is 1250 dots in the vertical direction).

Select printing direction/position

Syntax:

ESC T *n* or X'1B;54;*n*'

Where:

n

Table 14. Print direction

<i>n</i> =	Direction / position
X'00'	Left to right / top left
X'01'	Bottom to top / bottom left
X'02'	Right to left / bottom right
X'03'	Top to bottom / top right

Remarks:

When sent in standard mode, this command sets the print direction for page mode, but has no effect on standard mode printing.

Starting position is within the printable area defined by the *Select printable area* command (X'1B;58...)'.

Set vertical position

Syntax:

GS \$ *y* or X'1D;24;*y*'

Where:

y is a two-byte vertical printing position (in dots)

Remarks:

- Applies to page mode only.
- Moves the printing position to the specified dot position perpendicular to the printing direction specified by the *Select printing direction* command. If printing direction is bottom-to-top, or top-to-bottom, this command adjusts the printing position in the horizontal direction.
- If the value of *y* is outside the specified printable area, this command is ignored.

Set relative vertical position

Syntax:

GS \ *y* or X'1D;5C;*y*'

Where:

y is the two-byte vertical printing position (in dots).

Remarks:

- Applies to page mode only.

- Moves the printing position the specified number of dots from the current print position, in the direction perpendicular to the printing direction specified by the *Select printing direction/position* command (X'1B;54...'). If the print direction is bottom-to-top, or top-to-bottom, this command adjusts the printing position in the horizontal direction.
- If the value of *y* is outside the specified printable area defined by the *Select printable area* command, this command is ignored.
- If *y* is a negative value, the current print position will move in the opposite direction.

Set left margin position (standard mode), set absolute print position (page mode)

Syntax:

ESC \$ *n1 n2* or X'1B;24;*n1;n2*'

Where:

- *n1* is the high-order byte of the dot offset from the beginning of the print line.
- *n2* is the low-order byte of the dot offset from the beginning of the print line.

Default:

n1 = 0, *n2* = 0

Remarks:

- In the thermal station, 1 mm = 8 dots.
- In the impact station, 1 inch = 150 half-dots (75 dots).
- *n1* and *n2* are hex values. Convert each to decimal, and use this formula to get the decimal equivalent: (*n1* × 256) + *n2*.
- The maximum value in the thermal CR station is 576. The maximum value in the impact DI station is 474.
- In the CR station, this number is rounded back to a factor of 8.
- If the *n1,n2* value exceeds the maximum, it is ignored.
- This command should be sent only after the command that selects the station, *Set print station* (ESC *c1 n*).
- In Page mode, the printing position is moved the specified number of dots from the beginning of the print line, in the same direction as printing, specified by the *Select printing direction/position* command (X'1B;54...'). If the print position is bottom-to-top, or top-to-bottom, this command adjusts the print position in the vertical direction.
- This is a one-time adjustment on the current line. If this command moves the print position outside the printable area specified by the *Select printable area* command, it is ignored.

Set relative horizontal position

Syntax:

ESC <5C>h *n1 n2* or X'1B;5C;*n1;n2*'

Where:

- *n1* is the high-order byte of the dot offset, relative to the left margin in standard mode or the current print position in page mode.

- $n2$ is the low-order byte of the dot offset, relative to the left margin in standard mode or the current print position in page mode.

default:

$n1 = 0, n2 = 0$

Remarks:

- In the thermal station, 1 mm = 8 dots.
- In the impact station, 1 inch = 150 half-dots (75 dots).
- $n1$ and $n2$ are hex values. To get the decimal equivalent, convert each to decimal, and then use this formula: $(n1 \times 256) + n2$.
- To move the position to the left, use a negative number.
- If this number plus the left margin exceeds the printable area, the command is ignored.
- In the CR station, this number is rounded back to factor of 8. See the *Set left margin position* command for more information.
- When printing in page mode, this is a one-time adjustment on the current line. If this command moves the current print position outside the printable area defined by the *Select printable area* command, the command is ignored.

Set printing position

Syntax:

GS] x y or X'1D;5D; x ; y '

Where:

- x is the two-byte horizontal position, with respect to the paper, regardless of printing direction.
- y is the two-byte vertical position, with respect to the paper, regardless of printing direction.

Remarks:

- This command allows complete control of the printing position with a single command.
- If either parameter is outside the printable area defined by the *Select printable area* command, the command is ignored.

Print, form feed and cut the paper

Syntax:

FF or X'0C'

Remarks:

- In standard mode, the data in the print buffer feeds the paper in the CR station or DI station by a preset amount, until the document exits the feed rollers. If a cutter is available (CR station only), it cuts the paper.
- In page mode, the printer prints the page, then returns to standard mode. The page loaded in the printer's buffer is cleared. The paper is not cut.

Print page in page mode

Syntax:

ESC FF or X'1B 0C'

Remarks:

- In standard mode, this command is ignored.
- In page mode, this command prints the page that is loaded in the printer. The page remains loaded in the printer's buffer and the printer remains in page mode. This should be used for repeatedly printing the same page, or if there is a template that is filled in with each printout.

Clear print data in page mode

Syntax:

CAN or X'18'

Remarks:

This command deletes all print data in the current printable area of the page stored in the print buffer.

Chapter 4. Document handling

To read checks, insert them from the front of the printer. Use the side load capability only for documents that must be positioned to begin printing at a particular location on the document. (There is an arrow on the side of the cover to indicate where printing begins.) Use front load for all other cases.

Portrait mode

This is a suggested method of document handling:

1. ESC f (x) (y): Set up document wait time

- x Time the printer should wait from receiving a print line for the document station until the document is inserted.

If the document has not been detected by the time the wait time ends, a document error is sent to the system but the system continues to wait for a document to be inserted.

- y Delay from the time the document is detected until it is *grabbed* by the printer (the start of document printing):
 - Side insertion - closes the document throat.
 - Front insertion - pulls the document into the printer and feeds it to the Top of Form.

2. ESC c 0 X'04': Select document station - normal print mode:

The document present indicator blinks until a document is detected, then it stays on continuously.

- If the document is inserted from the front, it is fed to the first print position after the document wait time. Then, commands in the printer buffer begin executing.
- If the document is inserted from the side, printing starts at the location where it was inserted.

(The document throat must be open to insert the document from the side.) Manually, open the throat by pressing and then releasing both buttons. You can also open it with these commands - ESC q or ESC < X'01'.

If a document is not detected within the wait time (specified in the ESC f command), the printer sends error status to the system, and continues to wait.

Note: The system can either cancel the print buffer, thereby deleting all data in the print buffer, or wait for a document to be inserted.

The printer appears to be hung until an action is taken.

3. Send print lines to be printed in this station.

4. Final handling.

You have an option on final handling, finish printing and either eject the document or open the document throat to allow manual removal of the document:

FF: Print and Eject Document.

Finish printing and eject the document.

Landscape mode

Landscape mode printing is primarily for printing the face of a check.

Notes on landscape printing:

- Lines you send to print start at the bottom of the form, against the right stop, and continue to the top of the form, to a maximum of 80 mm from the bottom of the form. This is because the bottom of the form is known (against the right stop) and the top of the form is unknown to the printer.
- Different lengths of paper allow different print-line lengths. Therefore, the application must know the size of the print line.
- The printer calculates the length of a document it is to print. To do that, it must feed the document up past the bottom sensor and back to the top sensor. (On a 5-inch document this takes 2 seconds.) If a MICR read was done previously, the length was calculated at that time.
- When landscape mode is used without the check flipper, the document should be inserted so that the right edge is at the top of the printer, and the bottom edge is against the printer's right wall.
- To position the printing in landscape mode to the correct position, the system must send line feeds. The printer assumes that the top of form for a document in landscape mode is the far left edge of the document (to a maximum of 80 mm from the bottom of the form).
- Line feeding is 5 steps per mm or 21 steps per line, at 6 LPI.
- All landscape printing must be done with one printing pass. Therefore:
 - Double-high printing is not allowed.
 - User-defined characters greater than 9 dots high are not allowed.
- There is no error recovery for landscape printing.
- Set print station to document landscape mode to print the face of the check as it comes out of the flipper mechanism.

Landscape printing commands

1. ESC f (x) (y): Set up document wait time

Same as for portrait mode.

2. ESC c 0 X'08': Select document station - landscape print mode:

A If the document was not previously loaded:

- The document present indicator blinks until a document is detected.
- Once detected, the document will be *grabbed* by the printer and fed to the right margin on the document. Because the document is inserted on its side, this is at the top of the printer.
- If a document is not detected within the wait time (specified in the ESC f command), the printer sends error status to the system, and continues to wait.

The system can either cancel the print buffer, deleting all data in the print buffer, or wait for a document to be inserted.

The printer appears to be hung until an action is taken.

B If the document was previously loaded, the printer feeds the paper to the right margin on the document.

3. Send print lines to be printed in this station.

The number of characters that can be printed on a line depends on the width of the document. The print area is:

- 63 mm high, starting 17 mm from the bottom of the document
- The entire width of the document less 34 mm from the right edge and 10 mm from the left edge

4. Final handling.

You have an option on final handling: finish printing and either eject the document or open the document throat to allow manual removal of the document:

4a. FF: Print and Eject Document.

Finish printing and eject the document.

4b. ESC q or ESC < X'01': Open Document Throat

Finish printing and release the document from the printer's rollers.

Note: The document station stays selected. The printer will wait for another document until the station is changed.

Chapter 5. Status information

Models 2CR and 2NR have 16 status bytes. When Models 2CR and 2NR is in emulation mode the status bytes will reflect the status of the older 4610 models. Status is sent to the system for the following conditions:

Table 15. Summary of status conditions

- Cash receipt print error. The cover is open or out of paper.
- Printer buffer empty. If enabled, see “Status sent to system” on page 50.
- Document sensor state changed. If enabled, see “Status sent to system” on page 50.
- Cash drawer sensor change. If enabled, see “Status sent to system” on page 50.
- Nonrecoverable home error.
- Document not inserted after document station was selected.
- Document sensor is covered or cleared.
- Flash EPROM load error.
- Memory sector is full.
- User flash storage is full.
- Printer ID request (extended address command).
- MICR read command.
- MCT read command.
- User flash read command.
- Print buffer being held.
- Ribbon cover sensor change.
- Document feed error.
- Low Paper Detected
- Out of paper
- Thermal Paper Jam
- Cutter failure
- DI feed slip

Message from the printer

A message from the printer has this format:

Bytes	Contents
1 - 2	Data count (X'000A' to X'00FF'). The data count includes the two data-count bytes.
3 - 19	Status bytes 1-16. See the descriptions of each byte in the sections that follow.
20 - <i>n</i>	Either 5 bytes of additional status from the “Extended address command-request printer ID” on page 14 command, or up to 246 bytes of user data that can include: <ul style="list-style-type: none">• MICR data• User flash data• MCT data

Status byte 1

Table 16. Status byte 1

Bit	Description
0 (LSB)	Command complete (immediate command and flash storage commands). Set to 1 when the command is complete.
1	Reserved
2	Document left home position. Set to 1 when the print head is in the left home position.
3	Document right home position. Set to 1 when the print head is in the right home position.
4	Reserved. Always 0.
5	Ribbon cover open. Set to 1 when the ribbon cover is open.
6	Compatibility mode will set this bit on cover open/out of paper/paper jam or cutter jam. Native mode will only set this bit for cover open.
7 (MSB)	Command reject.

Status byte 2

Table 17. Status byte 2

Bit	Description
0 (LSB)	Document ready. Set to 0 when the document insert station is ready for printing. This occurs when both document sensors detect the document and the document has been fed to the first print position.
1	Document present under the front sensor. Set to 0 when a document is under to top document sensor.
2	Document present under the top sensor. Set to 0 when a document is under the top document sensor.
3	Reserved. Always equals 1.
4	Print buffer held. Set to 1 when the print buffer is being held. Cleared when buffer released. The printer can be held due to a Hold buffer Command or one of the following printer errors: Ribbon cover open, with commands to be printed on the document station. Cash receipt print error with commands to the cash receipt station.
5	Open throat position. Set to 1 when the print head is in the open throat position.
6	Buffer empty. Set to 1 when no print data and no commands are in the buffer.
7 (MSB)	Buffer full. Set when the message pipe is 80% full. Cleared when the message pipe is 60% full. Commands will be rejected when pipe is 100% full.

Status byte 3

Table 18. Status byte 3

Bit	Description
0 (LSB)	Electric journal memory sector is full.
1	Home error.

Table 18. Status byte 3 (continued)

Bit	Description
2	Document error. the document was not inserted after the document station was selected, and the wait subsequently timed out.
3	Flash EPROM load error or MCT load error.
4	Reserved. Always equals 0.
5	User flash storage sector is full.
6	Firmware error. CRC on the firmware failed. The printer is running out of the boot sector. Only system commands and firmware commands are accepted. The firmware must be reloaded into the printer.
7 (MSB)	Fiscal bit. Set to show a line completed printed. Set to 1 when Flash erase is complete.

Status byte 4

Contains the printer engineering code (EC) level with all status messages.

Status byte 5

Table 19. Status byte 5

Bit	Description
0 (LSB)	Printer ID Request/Extended Address command. Set to 1 when responding to a Printer ID request.
1	EC Level. Set to 1 when responding to an EC level request.
2	MICR Read. Set to 1 when responding to a MICR read command.
3	MCT Read. Set to 1 when responding to an MCT read command.
4	User flash read. Set to 1 when responding to a flash read command.
5	Reserved. Defaults to 1.
6	Reserved
7 (MSB)	Reserved

Status byte 6

Contains the current line count.

Status byte 7

Table 20. Status byte 7

Bytes	Description
0 (LSB)	Reserved
1	Lost +24V. Set when +24V drops below +20V. Note: If the printer is powered off with the power switch, this status will go out as the printer shuts down.
2	PDF417 bar code generation problem. Set to one when there is a problem creating a PDF417 bar code image.
3	Cash drawer status.
4	Print key pressed. Set to one when a printer key operation is in progress.
5	Reserved. Defaults to 1.

Table 20. Status byte 7 (continued)

Bytes	Description
6	Station selected. Set to 1 when document insert station is selected. Clear when the cash receipt station is selected.
7 (MSB)	Feed error. This is a document feed error: Set when there is an error after a Flip Check or a MICR command is executed.

Status byte 8

Table 21. Status byte 8

Bit	Description
0 (LSB)	Reserved
1	Reserved
2	Reserved
3	Reserved
4	Reserved (always 0)
5	Set to 1 when CR paper is out.
6	Magnetic noise present - only for MICR read command - "1" when MICR read shows random noise count ≥ 100 decimal or periodic noise > 0 , otherwise "0". If set to a "1", this value will be in the status message when status byte 5, bit 2 = "1" otherwise it will be a "0" in other status messages. When magnetic noise present bit is set there is excessive magnetic noise which might be due to a fan or CRT and it will affect the accuracy of the MICR reading.
7 (MSB)	Thermal Print Algorithm Engaged: The thermal algorithm pauses printing to safeguard the parts in the printer when either the print head or the paper feed motor is considered too hot to continue printing. The bit clears when the printer has cooled down. Prior to 2xR/1xR level 09.xx, this bit was set when the printer was almost too hot to continue printing. Pass these levels, the bit is set only when the algorithm is actually engaged. Note: The printer stops printing when the temperature exceeds 65° C, and will restart printing when the temp is below 60° C.

Status byte 9

Table 22. Status byte 9

Bit	Description
0 (LSB)	Electronic journal error (see driver spec for support)
1	Marker attached
2	Reserved
3	Reserved
4	Reserved (always 0)
5	Reserved
6	Printer is in offline mode, or has an unrecoverable error.
7 (MSB)	Reserved

Status byte 10

Table 23. Status byte 10

Bit	Description
0 (LSB)	Reserved
1	Electronic journal suspend (see driver spec for electronic journal support)
2	Set when responding to checksum request for download graphics logos or stored messages.
3	Reserved
4	Reserved (Always = 0)
5	Reserved
6	Reserved
7 (MSB)	Reserved

Status byte 11

Table 24. Status byte 11

Bit	Description
0 (LSB)	CR feed error - no motion detected when line feeding.
1	Reserved
2	Detected partial paper cut. Cutter may be failing.
3	Unexpected cover open. This bit will be set when the cover is open, where there isn't an error condition.
4	Reserved (always = 0)
5	Cutter jam. CANNOT print in the CR station when this bit is set.
6	Set to 1 when CR paper is low.
7 (MSB)	Set to 1 when CR paper is critically low.

Status byte 12

This will contain information RMA should monitor.

Table 25. Status byte 12

Bit	Description
0 (LSB)	Reserved
1	Document feed slip detected. Document does not appear to move as far as it should when feeding. Tested during MICR read and landscape print.
2	Reserved
3	Unexpected DI cover open. This bit will be set when the cover is open and there has not been an error.
4	Reserved (Default = 0)
5	High voltage detection. The printer will be offline if this bit is set.
6	Reserved

Table 25. Status byte 12 (continued)

Bit	Description
7 (MSB)	Reserved

Status byte 13

The printer can detect problems with the cards and might be able to communicate. If it can communicate, these are the statuses that are sent. If the failure is such that the printer cannot print, offline status will be set, and the CR LED will blip.

Table 26. Status byte 13

Bit	Description
0	(LSB) Main logic card - CRU failure
1	Interface logic card - CRU failure
2	Thermal print head - CRU failure
3	Impact print head failure (not a CRU)
4	Reserved (Always = '0')
5	Motion sensor failure (not a CRU)
6	Reserved
7 (MSB)	Reserved

Status byte 14

Table 27. Status byte 14

Bit	Description
0	(LSB)
1	
2	
3	
4	Reserved (Always = '0')
5	Problem communicating with the thermal print head
6	Executing offline test via command or keys
7 (MSB)	Printing EJ data

Status byte 15

Table 28. Status byte 15

Bit	Description
0	(LSB)
1	
2	
3	
4	
5	
6	

Table 28. Status byte 15 (continued)

Bit	Description
7 (MSB)	Reserved (Always = '1')

Status byte 16

The printer detects problems communicating with the thermal print head.

Table 29. Status byte 16

Bit	Description
0 (LSB)	ISB count: The lower bits of the number stored at the IPL count statistic
1	IPL count: The lower bits of the number stored at the IPL count statistic
2	IPL count: The lower bits of the number stored at the IPL count statistic
3	
4	
5	
6	
7 (MSB)	Reserved (Always = '1')

Chapter 6. Character fonts

This section describes font capabilities. For more information about font-related commands, see:

- “Download user-defined characters” on page 23
- “Set print station” on page 40
- “Set print mode” on page 35
- “Set code page” on page 41
- “Set intercharacter spacing for single byte character sets” on page 42
- “Select user-defined or resident character sets” on page 41

Thermal printing font

The number of characters printed per inch depends on the character size, the intercharacter spacing, and the chosen font. For example:

- 17 cpi = 10-dot wide character + 2-dot space (font A) = 48 characters per line
- 15 cpi = 10-dot wide character + 3-dot space (font A) = 44 characters per line
- 12 cpi = 12-dot wide character + 5-dot space (font B) = 34 characters per line
- 20 cpi = 8-dot wide character + 2-dot space (font C) = 57 characters per line

You can choose the character size of four user-defined character sets (code pages) or two proportional fonts. The parameter ranges for user-defined character sets are:

- $8 \leq \text{dot width} \leq 32$
- $16 \leq \text{dot width} \leq 32$
- Height must be a multiple of 2, such as 20, 22, 24, 26 and so forth.

Notes:

1. Any of the thermal printing fonts can be scaled up to eight times the defined width and eight times the defined height. The scaling factor for the width does not have to equal the scaling factor for the height. For example, you could specify twice the width and five times the height.
2. For paper that has a width of 80 mm, the cash receipt print line is 72 mm (2.83 in.) long. There are 576 dots per line and 203 dots per inch.

Proportional fonts

This section describes the procedure for converting and downloading proportional fonts. It also gives recommendations that will simplify implementing proportional fonts on a receipt.

Preparing the fonts

Download proportional fonts to the SureMark as follows:

1. Convert a TrueType font to the SureMark proportional font format. Use the IBM Proportional font conversion utility, `fontconvert.exe`, to convert the fonts. See “Proportional fonts.”
2. Download the converted font file to the printer.

Implementing proportional fonts

The variable width of proportional fonts can make it difficult to layout a receipt using traditional methods. you can simplify the process of laying out the format of a receipt by using the alignment and tab features of the SureMark printer.

The following topics show how to use the alignment and tab features with proportional fonts. Command descriptions are given in RS-232 (EIA-232) command format. For the command syntax when you use a printer driver, consult the driver documentation.

A single proportional character set requires two user-defined code pages. Therefore, the printer allows the following combination of user-defined and proportional character sets to be stored in the printer.

Number of Proportional Character Sets	Number of User-Defined Character Sets
0	4
1	2
2	0

Selecting code page 2 when a proportional character set is defined for code page 1 (or selecting code page 4 when proportional characters are defined in code page 3) will result in unreadable characters being printed.

A proportional character set is enabled using the select User-Defined Characters command.

Layout using align commands

A common requirement for receipt layout includes aligning item prices. This is commonly accomplished using fixed field lengths for item descriptions or counting characters. Using proportional fonts makes this method of alignment practically impossible.

The simplest method to align prices is to use the Align Column Right command with the Fix Font Matrix command.

- Unlike other Align Position commands, the Align Positions-Align Column Right command can be sent in the middle of a print line. Print characters sent before the alignment command will be left aligned, while characters sent after the alignment command will be right aligned.
- The Fix Font Matrix command forces proportional characters to print using a single width defined by the command. This essentially negates the proportional characteristic of the font, while still allowing the user to utilize the custom font. The following sequence assumes proportional characters have been downloaded and selected for printing. The following sequence should be used for each item line. The printer output would resemble the following:

```
Candy Bar      $ .45
Fountain Soda  $ 1.11
```

1. Print the item description. For the first item, this is the ASCII data Candy Bar.
2. Issue the Set Alignment command with n=4 (Right Align Column). The command syntax is X'1B 61 04'.
3. Issue the Fix Font Matrix command with n=dot width of the widest number used. The command syntax is X'1B 3A xx'.

Note: Finding the optimum value of xx for this command will vary depending on the proportional character set being used, and may require some experimentation.

4. Print the item price. For the first item, this is the ASCII data \$.45.
5. Issue the Fix Font Matrix command with n=0, which disables the fixed font matrix. The command syntax is X'1B 3A 00'.
6. Issue the Print and Line Feed command. Use the command syntax X'0A' or X'0D'.

Layout using set tab position

In situations where you do not need the price right aligned, or where you require an additional column (for example, a column for quantity), using tabs is the best method to guarantee alignment. Tab positions that you define during the setup operation will remain intact until the printer is reset or re-initialized. Once tabs are setup, all that is required is to send a tab character X'09' to move to the next tab position. Use the Fix Font Matrix if alignment of the individual characters in a field is important (for example, to align the decimal points of prices).

The following Set Tab Positions command will define tab positions for 3 columns: item description, quantity and price. The command assumes that the font width is approximately 10 dots. This procedure assumes that proportional characters have been downloaded and selected for printing, and that the item description will be left aligned.

```
X'1B 44 01 90 01 D6 00 00'
```

The following sequence should be used for each item line. The printer output would resemble the following:

```
Candy Bar    03 $ 1.00  
Fountain Soda 10 $11.10
```

1. Print the item description. For the first item, this is the ASCII data Candy Bar.
2. Issue the Tab command. The command syntax is X'09'.
3. Issue the Fix Font Matrix command with n=dot width of the widest number used. The command syntax is X'1B 3A xx'.

Note: Finding the optimum value of xx for this command will vary depending on the proportional character set being used, and may require some experimentation.

4. Print the quantity. For the first item, this is the ASCII data 03.
5. Issue the Tab command. The command syntax is X'09'.
6. Print the price. For the first item, this is the ASCII data \$1.00.
7. Issue the Fix Font Matrix command with n=0, which disables the fixed font matrix. The command syntax is X'1B 3A 00'.
8. Issue the Print and Line Feed command. Use the command syntax X'0A' or X'0D'.

Proportional font conversion utility

IBM provides three True Type fonts and a utility that you can use to convert the fonts to files that the SureMark printer can use. The application and instructions for downloading the converted fonts are available from the Retail Store Solutions Web site.

Note: You might have True Type fonts other than those supplied by IBM on your system. Before using the conversion utility to convert and download any non-IBM fonts for use by the SureMark printer, you must confirm that you have received authorization from the owner of the fonts to convert and download the fonts.

Chapter 7. Tests and diagnostics

This section describes the tests available for the 4610 Models 2xR and 1xR printers.

Low paper sensing and calibration

Low paper sensing is based upon the paper thickness and the core size. You can modify the low paper and critically low sensing settings. These settings determine the amount of paper that remains on the roll and at which time the low paper and the critically low paper status is sent. The default settings for low paper status is 5 meters (or 5000 mm) remains on the roll and for critically low is 1 meter (or 1000 mm).

Note: Prior to turning off the printer, send a reset command to the printer. If you turn off the printer without a reset command, when you turn the printer back on, it starts counting motor steps from the number stored in the printer's memory. This is not an accurate number if the printer was not able to store the number with a reset command.

For Models 1xR, the low-paper sensor is customer-selectable for table or wall mount, depending on application. The printer comes from the factory already in table mount mode. For wall mount applications, you must move the low-paper selector switch on the bottom of the printer to the WALL position.

You must calibrate the printer to accurately recognize the thickness of the paper supply. Calibration can be done using an offline test or by a command. See "Set low paper calibration" on page 48, "Summary of the offline test menus (Models 2xR)" on page 103, or "Summary of the offline test menus (Models 1xR)" on page 108.

One printer can be calibrated for the paper supply. The calibration constant can then be broadcast to all printers that will use the same paper.

To set the low paper supply sensors of all printers within your system:

1. Run the calibration on one printer. See Table 30.
2. Read out MCT#0x28 from the calibrated printer.

Note: The calibration constant is stored in MCT 0x28. System management can interrogate all printers to see if one has been recently calibrated.

3. Clear the high-order bit and send the value to all printers in the enterprise.

Table 30. MCT load command settings for low paper and critically low paper

Dec	Hex	
38	26	Low paper amount. This is the amount of paper left in the printer when the low paper status is sent. Default is 5 meters (5000 or 0x1388 number stored as mm).
39	27	Critically low paper amount. This is the amount of paper remaining in the printer when the low paper status is sent. Default is 1 meter (1000 or 0x03E8 number stored as mm).

Table 30. MCT load command settings for low paper and critically low paper (continued)

Dec	Hex	
40	28	LowPaperCalibrationConstant; The high order bit to this variable is set after this printer has calibrated the Low Paper. The lower order bits are the number of mm the printer will feed after detecting the sensor change until the paper is out.

Firmware offline tests (Models 2xR)

To enter the firmware offline test and setup procedures for 4610 Models 2xR, complete the following steps:

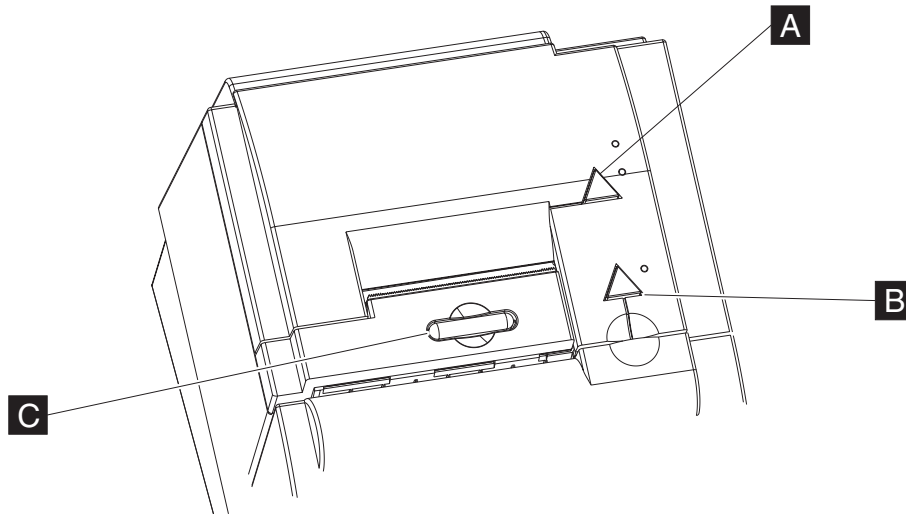

Figure 3. Paper feed and document feed buttons

1. Open the paper cover (**C**) and press the power button to power on the printer. The power button comes with a cover over it, so it may be necessary to use a paper clip or similar item to push the button through the cover. See Figure 4 on page 103 for the location of the power button.

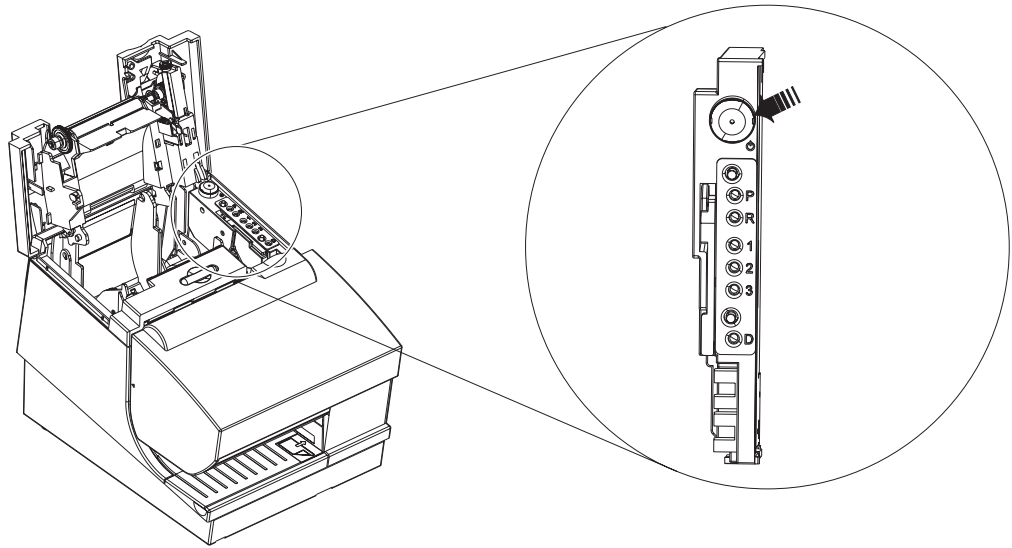

Figure 4. Pressing the power button

2. Close the paper cover and press the paper feed button (**A**) while the printer is powering up.
3. The following offline selection menu is printed. See Figure 5.

```

Off-line Selection started
To select a sub-menu or test:
FIRST, press the paper feed button the indicated number of times.
THEN, press again and hold button down at least 1
second to confirm selection.
  
```

Sub-menus and tests	Press
Thermal Receipt test	1
Choose Emulation Mode	2
Model Selection	3
EIA-232/RS-232 Flow Control	4
More Selections	5

To exit Off-line setup, open printer cover.

Figure 5. Example of the offline selection main menu. See Table 31 for an explanation of these menu items.

4. Follow the instructions that are printed for each required test.

Summary of the offline test menus (Models 2xR)

Use the firmware offline test menus to perform the offline tests. However, note that some existing offline test methods still apply (see “Earlier methods for offline tests” on page 106). Table 31 describes the available firmware offline test menus:

Table 31. Summary of the offline test menu items

Menu item	Definition	Sub-menu (if applicable)	Definition
1. Thermal receipt test	Prints a receipt		

Table 31. Summary of the offline test menu items (continued)

Menu item	Definition	Sub-menu (if applicable)	Definition
2. Choose emulation mode	Displays the submenus (see next column)	Compatibility with Legacy 4610	Changes the command set and statuses to support the previous drivers and applications (such as plug and play for existing 4610 printers).
		Native mode	Changes the command set and statuses to support the low-paper detection, paper jam detection, and other 4610 Model 2xR sensors.
3. Model selection	You specify the printer type: MICR reading or non-MICR reading model.		
4. EIS-232/RS-232 flow control	Provides a list of available baud rates and flow controls.		
5. More selections	Provides additional menus:		
6. MCT listing	Information for service personnel		
7. Low-paper calibration	You are instructed to insert a <i>small</i> roll of paper in the printer. During the test the printer ejects all of the paper from this roll to calibrate the low-paper sensor.		
8. MICR read test (Model 2CR only)			
9. Document print test	Starts print test		
10. For more selections:	Provides additional menus:		
11. Hex dump mode	A debug mode that is used when attached using a RS 232 that will have the printer print the data/commands that it receives. This enables the application writer the ability to see what data is actually being received at the printer.		
12. Execute printhead test	Starts printhead test		
13. Reset TPH user data Execute after thermal Printhead is replaced	Select after you install a new thermal printhead.		
14. Paper out sensor test	Checks the operation of the paper-out sensor.		
15. Resident code pages	Prints out a test page for the Code Pages resident in the printer.		
14. Main menu	Return to main menu		

Changing the interface card or logic card

During the servicing process, you often will change an interface card or logic card in the printer. If one of the cards is a new FRU, then the printer firmware automatically updates the new card with the printer settings and other information. (These settings include the serial number, baud rate, and model number.) The first time you power on the printer with a FRU card in it, the update will occur and the printer will reset.

For proper operation, the information on the interface and logic cards must match. If you install either card (interface or logic) with previously written firmware information, you must direct the firmware to overwrite the correct card.

The following message is printed when an information mismatch occurs:

A card in the printer has been replaced
Main Logic's S/N is 41-MVT02
Interface Card's S/N is 41AAVT50
Check the serial number (S/N) of the
printer. The S/N is located next to the
document insert station and on the
bottom of the printer.

If S/N matches one of the above, please
update the card with the incorrect S/N.

If S/N does not match one of the above,
Refer to the Hardware Service Manual.

To select a sub-menu or test:
FIRST, Press the paper feed button
the indicated number of
times.
THEN, press again and hold
button down at least 1 second
to confirm selection.

OPTIONS. Press
1. Main Logic Update Menu 1
2. Interface Card Update Menu . . 2
3. Continue without updating . . 3

To exit Off-line setup, open printer cover.

If you select option 1, the following message prints:

Main Logic Card Update Menu
Data will be copied from the
interface card to the main logic
Printer will reset when update is done.
To update the Main Logic Card,
Press the paper feed button

To Exit without updating, Open Printer Cover.

If you select option 2, the following message will print:

Interface Card Update Menu
To update the Interface Card,
Press the paper feed button
Data will be copied from the
main logic to the Interface Card.

To Exit without updating,
open printer cover

Selecting Option 3. Continuing without updating could produce unexpected
results.

Storing a new serial number in the firmware

For proper printer operation, the firmware must correlate the serial number of the
printer with the serial number of the logic card. When you replace either the logic
card or the interface card, the serial number is restored into the new card.
However, if both cards are replaced, you must store the correct serial number in
the firmware.

For more information, see the IBM Retail Store Solutions support Web site at
www.ibm.com/solutions/retail/store/support/.

Earlier methods for offline tests

The section provides the previous methods for initiating offline tests. Although these methods are supported, IBM recommends that you use the firmware menu and sub-menus to initiate all offline tests.

Resetting the printer and the document sensor threshold

To reset the printer,:

1. Press and hold the paper feed and document feed buttons (**A** and **B** in Figure 3 on page 102) to enter offline mode.
2. When the printer-ready indicator begins blinking, release both buttons.
3. Open and close the paper door by pressing the paper release button **C** in Figure 3 on page 102.

Customer receipt test

Note: IBM recommends that you use the offline menus to initiate this test.

To initiate the customer receipt test, follow these steps:

1. Press and hold both the paper feed and document feed buttons (**A** and **B** in Figure 3 on page 102) to enter offline mode
2. When the printer-ready indicator begins blinking, release both buttons.
3. Press and release the paper feed button to start the test

Document insert station test

Note: IBM recommends that you use the offline menus to initiate this test.

To initiate the document insert station test, follow these steps:

1. Press and hold both the paper feed and document feed buttons (**A** and **B** in Figure 3 on page 102) buttons to enter offline mode.
2. When the printer-ready indicator begins blinking, release both buttons.
3. Press and release the document feed button to start the test.

MICR read, flipper test (Model 2CR only)

Note: IBM recommends that you use the offline menus to initiate this test.

The MICR read test is accessed through the sub-menus in offline mode.

Follow these steps to start the MICR read and flipper test:

1. Insert the check face down with the magnetic ink characters to the right.
2. To enter offline mode, press and hold both buttons until the printer-ready indicator begins blinking.
3. Then release both buttons.
4. Press and release both buttons again. The printer reads the check.
5. Characters that match the magnetic ink characters are printed on the customer receipt. The check is then flipped over, and ejected.

Understanding MICR test results: If the characters printed do not match the magnetic ink characters, check the MICR read head. The printer will insert question marks if the MICR read engine cannot decode a number. If the printer detects noise, it will print out the amplitude and frequency of the noise, if possible.

Firmware offline tests (Models 1xR)

To enter the firmware offline test and setup procedures for Models 1xR, complete the following steps:

The following sections describe the steps to enter the firmware offline test and setup procedures for Model 1xR.

1. Open the top cover.
2. Press the white power reset switch (**A** in Figure 6) to turn the printer off and then on again.

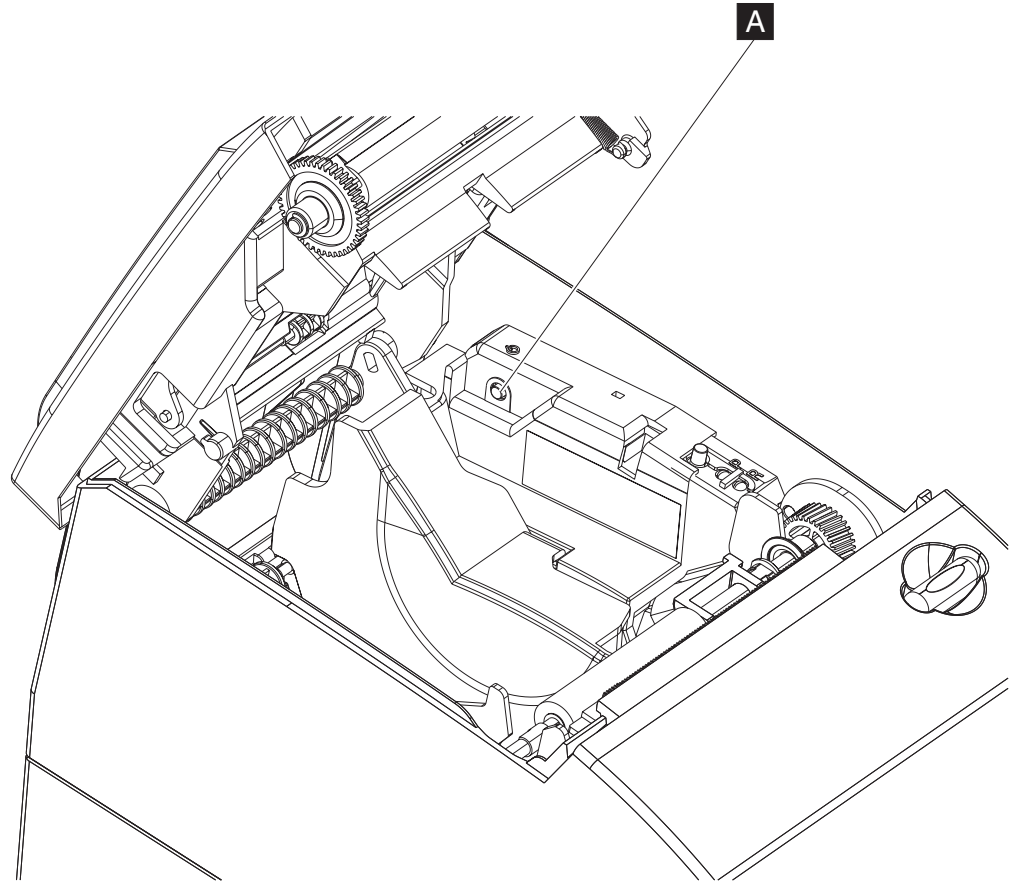

Figure 6. Offline tests activation

3. Close the top cover
4. While the printer is powering up, press and hold the paper feed button until the front LED indicator blinks. The offline test is printed (see Figure 7 on page 108).

Off-line Selection started
 To select a sub-menu or test:
 FIRST, press the paper feed button the indicated number of times.
 THEN, press again and hold button down at least 1 second to confirm selection.

Sub-menus and tests	Press
Thermal Receipt test	1
Choose Emulation Mode	2
Select receipt width	3
EIA-232/RS-232 Flow Control	4
More Selections	5

To exit Off-line setup, open printer cover.

Figure 7. Example of the offline selection main menu. See 108 for an explanation of these menu items.

- Follow the instructions that are printed for each required test.

Summary of the offline test menus (Models 1xR)

Use the firmware offline test menus to perform the offline tests. Table 32 describes the available firmware offline test menus for Models 1xR:

Table 32. Summary of the offline test menu items

Menu Item	Definition	Sub-menu (if applicable)	Definition
1. Thermal receipt	Prints a receipt		
2. Choose emulation mode	Displays the submenus (see next column)	Compatibility with Legacy 4610	Changes the command set and statuses to support the previous drivers and applications (such as plug and play for existing 4610 printers).
		Native mode	Changes the command set and statuses to support the low-paper detection, paper jam detection, and other 4610 Model 1NR, 1NA, and 1ND sensors.
		EPSON Emulation	Emulates an EPSON printer.
4. EIS-232/RS-232 flow control	Provides a list of available baud rates and flow controls.		
5. MCT listing	Provides information for service personnel.		
6. Low-paper calibration	You are instructed to insert a small roll of paper in the printer. During the test, the printer ejects all of the paper from this roll to calibrate the low-paper sensor.		
7. Hex dump mode	A debug mode that is used when attached using a RS-232 that will have the printer print the data/commands that it receives. This enables the application writer the ability to see what data is actually being received at the printer.		

Table 32. Summary of the offline test menu items (continued)

Menu Item	Definition	Sub-menu (if applicable)	Definition
8. Execute printhead test	Starts printhead tests.		
9. Reset TPH user data.	Select after you install a new thermal printhead.		
10. Motion sensor test	Starts the test up		
11. Print resident code pages	Prints all resident code pages with options of font choice		
12. Main menu	Returns to main menu		

Storing a new serial number in the firmware after a logic or interface card change

During the servicing process, you might have to change an interface card or logic card in the printer.

For proper printer operation, the firmware must correlate the serial number of the printer with the serial number of the logic card. When you replace either the logic card, you must store the correct serial number in the firmware.

For more information, see the IBM Retail Store Solutions support Web site at www.ibm.com/solutions/retail/store/support/.

Customer receipt test

Use the offline menu to initiate the customer receipt test.

Notices

This information was developed for products and services offered in the U.S.A.

IBM may not offer the products, services, or features discussed in this document in other countries. Consult your local IBM representative for information on the products and services currently available in your area. Any reference to an IBM product, program, or service is not intended to state or imply that only that IBM product, program, or service may be used. Any functionally equivalent product, program, or service that does not infringe any IBM intellectual property right may be used instead. However, it is the user's responsibility to evaluate and verify the operation of any non-IBM product, program, or service.

IBM may have patents or pending patent applications covering the subject matter in this document. The furnishing of this document does not give you any license to these patents. You can send license inquiries, in writing, to:

IBM Director of Licensing
IBM Corporation
North Castle Drive
Armonk, NY 10504-1785
U.S.A.

For license inquiries regarding double-byte character set (DBCS) information, contact the IBM Intellectual Property Department in your country or send inquiries, in writing, to:

IBM World Trade Asia Corporation
Licensing
2-31 Roppongi 3-chome, Minato-ku
Tokyo 106, Japan

The following paragraph does not apply to the United Kingdom or any other country where such provisions are inconsistent with local law: INTERNATIONAL BUSINESS MACHINES CORPORATION PROVIDES THIS PUBLICATION "AS IS" WITHOUT WARRANTY OF ANY KIND, EITHER EXPRESS OR IMPLIED, INCLUDING, BUT NOT LIMITED TO, THE IMPLIED WARRANTIES OF NON-INFRINGEMENT, MERCHANTABILITY, OR FITNESS FOR A PARTICULAR PURPOSE. Some states do not allow disclaimer of express or implied warranties in certain transactions, therefore, this statement may not apply to you.

This information could include technical inaccuracies or typographical errors. Changes are periodically made to the information herein; these changes will be incorporated in new editions of the publication. IBM may make improvements and/or changes in the product(s) and/or program(s) described in this publication at any time without notice.

IBM may use or distribute any of the information you supply in any way it believes appropriate without incurring any obligation to you.

Any references in this information to non-IBM Websites are provided for convenience only and do not in any manner serve as an endorsement of those websites. The materials at those websites are not part of the materials for this IBM product and use of those websites is at your own risk.

Information concerning non-IBM products was obtained from the suppliers of those products, their published announcements or other publicly available sources. IBM has not tested those products and cannot confirm the accuracy of performance, compatibility or any other claims related to non-IBM products. Questions on the capabilities of non-IBM products should be addressed to the suppliers of those products.

This information is for planning purposes only. The information herein is subject to change before the products described become available.

Electronic emission notices

Federal Communications Commission statement

This equipment has been tested and found to comply with the limits for a Class A digital device, pursuant to Part 15 of the Federal Communications Commission (FCC) Rules. These limits are designed to provide reasonable protection against harmful interference when the equipment is operated in a commercial environment. This equipment generates, uses, and can radiate radio frequency energy and, if not installed and used in accordance with the instruction manual, may cause harmful interference to radio communications. Operation of this equipment in a residential area is likely to cause harmful interference, in which case the user will be required to correct the interference at his own expense.

Properly shielded and grounded cables and connectors must be used in order to meet FCC emission limits. IBM is not responsible for any radio or television interference caused by using other than recommended cables and connectors or by unauthorized changes or modifications to this equipment. Unauthorized changes or modifications could void the user's authority to operate the equipment.

This device complies with part 15 of the FCC Rules. Operation is subject to the following two conditions:

1. This device may not cause harmful interference, and
2. This device must accept any interference received, including interference that may cause undesired operation.

European Union EMC Directive conformance statement

This product is in conformity with the protection requirements of EU Council Directive 2004/108/EC on the approximation of the laws of the Member States relating to electromagnetic compatibility. IBM cannot accept responsibility for any failure to satisfy the protection requirements resulting from a non-recommended modification of the product, including the fitting of non-IBM option cards.

This product has been tested and found to comply with the limits for Class A Information Technology Equipment according to CISPR 22/European Standard EN 55022. The limits for Class A equipment were derived for commercial and industrial environments to provide reasonable protection against interference with licensed communication equipment.

Attention: This is a Class A product. In a domestic environment this product may cause radio interference in which case the user may be required to take adequate measures.

European Community contact:

IBM Technical Regulations
Pascalstr. 100, Stuttgart, Germany 70569
Telephone: 0049 (0)711 785 1176
Fax: 0049 785 1283
E-mail: tjahn@de.ibm.com

Industry Canada Class A Emission Compliance statement

This Class A digital apparatus complies with Canadian ICES-003.

Avis de conformité aux normes d'Industrie Canada

Cet appareil numérique de la classe A est conforme à la norme NMB-003 du Canada.

Germany

Zulassungsbescheinigung laut dem Deutschen Gesetz über die elektromagnetische Verträglichkeit von Geräten (EMVG) vom 30. August 1995 (bzw. der EMC EG Richtlinie 89/336).

Dieses Gerät ist berechtigt in Übereinstimmung mit dem Deutschen EMVG das EG-Konformitätszeichen - CE - zu führen.

Verantwortlich für die Konformitätserklärung nach Paragraph 5 des EMVG ist die IBM Deutschland Informationssysteme GmbH, 70548 Stuttgart

Informationen in Hinsicht EMVG Paragraph 3 Abs. (2) 2:

Das Gerät erfüllt die Schutzanforderungen nach EN 50082-1 und EN 55022 Klasse A.
--

EN 55022 Klasse A Geräte müssen mit folgendem Warnhinweis versehen werden:

"Warnung: dies ist eine Einrichtung der Klasse A. Diese Einrichtung kann im Wohnbereich Funkstörungen verursachen; in diesem Fall kann vom Betreiber verlangt werden, angemessene Maßnahmen durchzuführen und dafür aufzukommen."

EN 50082-1 Hinweis:

"Wird dieses Gerät in einer industriellen Umgebung betrieben (wie in EN 50082-2 festgelegt), dann kann es dabei eventuell gestört werden. In solch einem Fall ist der Abstand bzw. die Abschirmung zu der industriellen Störquelle zu vergrößern."

Anmerkung:

Um die Einhaltung des EMVG sicherzustellen sind die Geräte, wie in den IBM Handbüchern angegeben, zu installieren und zu betreiben.

Australia and New Zealand

Attention: This is a Class A product. In a domestic environment this product may cause radio interference, in which case the user may be required to take adequate measures.

Chinese Class A warning statement

Attention: This is a Class A product. In a domestic environment this product may cause radio interference, in which case the user may be required to take adequate measures.

中华人民共和国“A类”警告声明

声 明

此为 A 级产品，在生活环境中，该产品可能会造成无线电干扰。在这种情况下，可能需要用户对其干扰采取切实可行的措施。

Japanese Electrical Appliance and Material Safety Law statement

本製品およびオプションに電源コードセットが付属する場合は、それぞれその装置専用のものになっていますので他の機器には使用しないで下さい。

Japanese power line harmonics compliance statement

高調波ガイドライン適合品

高調波ガイドライン適合品

Japanese VCCI Council Class A statement

Attention: This is a Class A product based on the standard of the VCCI Council. If this equipment is used in a domestic environment, radio interference may occur, in which case, the user may be required to take corrective actions.

この装置は、クラスA情報技術装置です。この装置を家庭環境で使用すると電波妨害を引き起こすことがあります。この場合には使用者が適切な対策を講ずるよう要求されることがあります。 VCCI-A

Japan Electronics and Information Technology Industries Association (JEITA) statement

高調波ガイドライン適合品

Japanese Electronics and Information Technology Industries Association (JEITA)
Confirmed Harmonics Guideline (products less than or equal to 20 A per phase).

Korean communications statement

Please note that this device has been approved for business purposes with regard to electromagnetic interference. If you find this is not suitable for your use, you may exchange it for a non-business purpose one.

A급 기기(업무용)

이 기기는 업무용으로 전자파적합등록을 받은 기기이오니 판매자 또는 이용자는 이점을 주의하시기 바라며, 만약 구입하였을 때에는 구입한 곳에서 가정용으로 교환하시기 바랍니다.

Taiwanese Class A warning statement

警告使用者：
這是甲類的資訊產品，在居住的環境中使用時，可能會造成射頻干擾，在這種情況下，使用者會被要求採取某些適當的對策。

Taiwan contact information

台灣IBM 產品服務聯絡方式：
台灣國際商業機器股份有限公司
台北市松仁路7號3樓
電話：0800-016-888

IBM Taiwan Product Service Contact Info:
IBM Taiwan Corporation
3F, No 7, Song Ren Road, Taipei Taiwan
Telephone: 0800-016-888

Cable ferrite requirement

All cable ferrites are required to suppress radiated EMI emissions and must not be removed.

Electrostatic discharge

Attention: Electrostatic discharge (ESD) damage can occur when there is a difference in charge between the part, the product, and the service person. No damage will occur if the service person and the part being installed are at the same charge level.

ESD damage prevention

Anytime a service action involves physical contact with logic cards, modules, back-panel pins, or other ESD sensitive (ESDS) parts, the service person must be connected to an ESD common ground point on the product through the ESD wrist strap and cord.

The ESD ground clip can be attached to any frame ground, ground braid, green wire ground, or the round ground prong on the AC power plug. Coax or connector outside shells can also be used.

Handling removed cards

Logic cards removed from a product should be placed in ESD protective containers. No other object should be allowed inside the ESD container with the logic card. Attach tags or reports that must accompany the card to the outside of the container.

Product recycling and disposal

This unit must be recycled or discarded according to applicable local and national regulations. IBM encourages owners of information technology (IT) equipment to responsibly recycle their equipment when it is no longer needed. IBM offers a variety of product return programs and services in several countries to assist equipment owners in recycling their IT products. Information on IBM product recycling offerings can be found on the IBM Website at www.ibm.com/ibm/environment/products/recycling.shtml.

Español:

Esta unidad debe reciclarse o desecharse de acuerdo con lo establecido en la normativa nacional o local aplicable. IBM recomienda a los propietarios de equipos de tecnología de la información (TI) que reciclen responsablemente sus equipos cuando éstos ya no les sean útiles. IBM dispone de una serie de programas y servicios de devolución de productos en varios países, a fin de ayudar a los propietarios de equipos a reciclar sus productos de TI. Se puede encontrar información sobre las ofertas de reciclado de productos de IBM en el sitio web de IBM www.ibm.com/ibm/environment/products/recycling.shtml.



Notice: This mark applies only to countries within the European Union (EU) and Norway.

Appliances are labeled in accordance with European Directive 2002/96/EC concerning waste electrical and electronic equipment (WEEE). The Directive determines the framework for the return and recycling of used appliances as applicable throughout the European Union. This label is applied to various products to indicate that the product is not to be thrown away, but rather reclaimed upon end of life per this Directive.

Remarque : Cette marque s'applique uniquement aux pays de l'Union Européenne et à la Norvège. L'étiquette du système respecte la Directive européenne

2002/96/EC en matière de Déchets des Equipements Electriques et Electroniques (DEEE), qui détermine les dispositions de retour et de recyclage applicables aux systèmes utilisés à travers l'Union européenne. Conformément à la directive, ladite étiquette précise que le produit sur lequel elle est apposée ne doit pas être jeté mais être récupéré en fin de vie.

注意: このマークは EU 諸国およびノルウェーにおいてのみ適用されます。

この機器には、EU 諸国に対する廃電気電子機器指令 2002/96/EC(WEEE) のラベルが貼られています。この指令は、EU 諸国に適用する使用済み機器の回収とリサイクルの骨子を定めています。このラベルは、使用済みになった時に指令に従って適正な処理をする必要があることを知らせるために種々の製品に貼られています。

In accordance with the European WEEE Directive, electrical and electronic equipment (EEE) is to be collected separately and to be reused, recycled, or recovered at end of life. Users of EEE with the WEEE marking per Annex IV of the WEEE Directive, as shown above, must not dispose of end of life EEE as unsorted municipal waste, but use the collection framework available to customers for the return, recycling, and recovery of WEEE. Customer participation is important to minimize any potential effects of EEE on the environment and human health due to the potential presence of hazardous substances in EEE. For proper collection and treatment, contact your local IBM representative.

Disposal of IT products should be in accordance with local ordinances and regulations.

Battery return program

This product may contain sealed lead acid, nickel cadmium, nickel metal hydride, lithium, or lithium ion battery. Consult your user manual or service manual for specific battery information. The battery must be recycled or disposed of properly. Recycling facilities may not be available in your area. For information on disposal of batteries outside the United States, go to www.ibm.com/ibm/environment/products/battery.shtml or contact your local waste disposal facility.

In the United States, IBM has established a return process for reuse, recycling, or proper disposal of used IBM sealed lead acid, nickel cadmium, nickel metal hydride, and other battery packs from IBM equipment. For information on proper disposal of these batteries, contact IBM at 1-800-426-4333. Please have the IBM part number listed on the battery available prior to your call.

For Taiwan:



Please recycle batteries.

For the European Union:



Notice: This mark applies only to countries within the European Union (EU)

Batteries or packaging for batteries are labeled in accordance with European Directive 2006/66/EC concerning batteries and accumulators and waste batteries and accumulators. The Directive determines the framework for the return and recycling of used batteries and accumulators as applicable throughout the European Union. This label is applied to various batteries to indicate that the battery is not to be thrown away, but rather reclaimed upon end of life per this Directive.

Les batteries ou emballages pour batteries sont étiquetés conformément aux directives européennes 2006/66/EC, norme relative aux batteries et accumulateurs en usage et aux batteries et accumulateurs usés. Les directives déterminent la marche à suivre en vigueur dans l'Union Européenne pour le retour et le recyclage des batteries et accumulateurs usés. Cette étiquette est appliquée sur diverses batteries pour indiquer que la batterie ne doit pas être mise au rebut mais plutôt récupérée en fin de cycle de vie selon cette norme.

バッテリーあるいはバッテリー用のパッケージには、EU 諸国に対する廃電気電子機器指令 2006/66/EC のラベルが貼られています。この指令は、バッテリーと蓄電池、および廃棄バッテリーと蓄電池に関するものです。この指令は、使用済みバッテリーと蓄電池の回収とリサイクルの骨子を定めているもので、EU 諸国にわたって適用されます。このラベルは、使用済みになったときに指令に従って適正な処理をする必要があることを知らせるために種々のバッテリーに貼られています。

In accordance with the European Directive 2006/66/EC, batteries and accumulators are labeled to indicate that they are to be collected separately and recycled at end of life. The label on the battery may also include a chemical symbol for the metal concerned in the battery (Pb for lead, Hg for mercury and Cd for cadmium). Users of batteries and accumulators must not dispose of batteries and accumulators as unsorted municipal waste, but use the collection framework available to customers for the return, recycling and treatment of batteries and accumulators. Customer participation is important to minimize any potential effects of batteries and accumulators on the environment and human health due to the potential presence of hazardous substances. For proper collection and treatment, contact your local IBM representative.

This notice is provided in accordance with Royal Decree 106/2008 of Spain: The retail price of batteries, accumulators and power cells includes the cost of the environmental management of their waste.

For California:

Perchlorate material – special handling may apply

Refer to www.dtsc.ca.gov/hazardouswaste/perchlorate.

The foregoing notice is provided in accordance with *California Code of Regulations Title 22, Division 4.5, Chapter 33: Best Management Practices for Perchlorate Materials*. This product/part includes a lithium manganese dioxide battery which contains a perchlorate substance.

Flat panel displays

The fluorescent lamp in the liquid crystal display contains mercury. Dispose of it as required by local ordinances and regulations.

Monitors and workstations

Connecticut: Visit the website of the Department of Environmental Protection at www.ct.gov/dep for information about recycling covered electronic devices in the State of Connecticut, or telephone the Connecticut Department of Environmental Protection at 1-860-424-3000.

Oregon: For information regarding recycling covered electronic devices in the state of Oregon, go to the Oregon Department of Environmental Quality site at www.deq.state.or.us/lq/electronics.htm.

Washington: For information about recycling covered electronic devices in the State of Washington, go to the Department of Ecology Website at <https://fortress.wa.gov/ecy/recycle/> or telephone the Washington Department of Ecology at 1-800Recycle.

Trademarks

The following are trademarks of International Business Machines Corporation in the United States or other countries, or both:

AnyPlace Kiosk(tm)
AnyPlace POS Hub(tm)
DB2
DB2 Universal Database
IBM and the IBM logo
PS/2
SureMark
SurePoint
SurePOS
Wake on LAN
WebSphere

Microsoft, Windows, Windows NT, and the Windows logo are trademarks of Microsoft Corporation in the United States, other countries, or both.

Celeron and Intel are trademarks of Intel corporation in the United States, or other countries.

Java and all Java-based trademarks and logos are trademarks or registered trademarks of Oracle and/or its affiliates.

Other company, product, or service names may be trademarks or service marks of others.

Index

Numerics

- 1/6-inch line spacing, selecting 44
- 1/8-inch line spacing, selecting 43
- 4610 Models 2xR
 - Firmware offline tests 102
 - offline test, firmware 102

A

- accessibility of publications xii
- align positions command 48
- asynchronous commands 74
 - data buffer management and batch printing 76
 - real-time requests 74

B

- backspace, composite characters 71
- batch printing, and data buffer management 76
- battery return program 118

C

- cable ferrite requirement 116
- cash drawer drive pulse command 73
- changing the interface card or logic card 104
- character that selects font a/b/c 35
- check processing commands 69
 - flip check 71
 - MICR read 69
- checksum of downloaded logo or message 29
- checksum of flash memory sector, request 29
- Class A compliance statement
 - Australia and New Zealand 114
 - China 115
 - European Union 113
 - FCC (USA) 113
 - Germany 114
 - Industry Canada 114
 - Japan 115
 - Taiwan 116
- code page command, set 41
- color printing, selecting 44
- communication parameters 5
- composite characters, backspace 71

D

- damage from electrostatic discharge 116
- data buffer management commands 76
- data buffer management, and batch printing 76
 - disable line count 77
 - EC level marker command 76

- data buffer management, and batch printing (*continued*)
 - hold printing until buffer is released 77
 - release print buffer 78
 - reset line count 77
- defaults, printer memory allocation 19
- define document wait time command 49
- disable feed buttons 52
- disable line count 77
- disable the beeper 51
- disable upside-down printing 52
- disposal of equipment 117
- document handling, landscape mode commands 86
- document handling, portrait mode commands 85
- document length, setting 39
- document sensor threshold, resetting 106
- double-byte characters 20
- double-high mode command, set or cancel 37
- double-wide mode command, set or cancel 37
- download graphics (logo) commands 20
- download user-defined characters command 23
- driver documentation by operating system 6

E

- EC level marker command 76
- EC request command 75
- edition notice ii
- electronic emissions notices 113
 - Australia and New Zealand 114
 - China 115
 - European Union 113
 - FCC (USA) 113
 - Germany 114
 - Industry Canada 114
 - Japan 115
 - Korea 115
 - Taiwan 116
- electrostatic discharge (ESD) 116
- emphasized printing command, set or cancel 38
- emulation mode for Model 2CR/2NR/1NR 16
- emulation of non-IBM printers 17
- enable feed buttons 52
- enable the beeper 51
- enable upside-down printing 52
- end of life disposal 117
- equipment disposal 117
- erase flash sector command 30
- error recovery command, set 49
- European Union battery recycling statement 119

- extended address command 15

F

- ferrite requirement 116
- firmware offline tests 102
 - changing the interface or logic card 104
 - offline test menu 103
 - storing a new serial number 105
- Firmware offline tests
 - 4610 Models 2xR 102
 - For 1xR 107
- firmware offline tests setup procedures 102
- fix font matrix 54
- flash storage write command 30
- flat panel displays 120
- flip check command 71

H

- hardware requirements 2
- hold printing command 77
- horizontal tab command 71
- horizontal tabs command, set 46

I

- impact code page command 27
- intercharacter spacing command, set for single byte character sets 42
- invert command, set or cancel 38

J

- Japan Electronics and Information Technology Industries Association statement 115
- Japanese Electrical Appliance and Material Safety Law statement 115
- Japanese power line harmonics compliance statement 115
- Japanese VCCI Council Class A statement 115

K

- Korean communications statement 115

L

- landscape mode 86
- landscape printing commands 86
- left margin command, set 46
- line spacing, minimum units 45
- line spacing, select 1/6 44
- line spacing, select 1/8 43

low paper sensing and calibration 101
low paper, sensing and calibration 101

M

MCT command definitions 31
MCT loading 31
memory allocation 18
mercury-added statement 120
message format 89
MICR read 69
MICR test results, understanding 106
microcode tolerance (MCT) information -
request 31
miscellaneous commands 71
 generate drive pulse for cash
 drawer 73
 horizontal tab 71
 paper cut/DI eject command 73
Prepare printer for shut down
(S3) 74
 retrieve the flash storage 73
 retrieve the size of user flash
 storage 74
 return home (select print head
 location) 28, 72
Models 1xR
 Firmware offline tests 107
 offline test, firmware 107

N

notices 111
 battery recycling 118, 119
 cable ferrites 116
 electronic emissions 113
 electrostatic discharge (ESD) 116
 end of life disposal 117
 IBM 111

O

offline selection menu
 For 1xR 107
offline test menu 103
offline test, firmware
 4610 Models 2xR 102
 For 1xR 107
offline tests
 customer receipt test 106
offline tests, earlier methods 106
onetime-set commands 18
operating system requirements 1
overline mode command, set or
 cancel 38

P

page mode commands 79
 clear print data in page mode 83
 page mode printing commands 79
 print and form feed and cut the
 paper 82
 print page in page mode 83
 select printable area 79

page mode commands (*continued*)
 select printing direction/position 80
 select standard mode 79
 set left margin position (standard
 mode), set absolute print position
 (page mode) 81
 set printing position 82
 set relative horizontal position 81
 set relative vertical position 80
 set vertical position 80
paper cut/DI eject command 73
paper, select thermal 55
perchlorate 119
portrait mode 85
predefine messages command 22
Prepare printer for shut down (S3) 74
preparing the fonts 97
preparing, the fonts 97
preset commands 18
print and line feed command 64
print character commands 64
print logo inline 54
print mode command, set 35
print predefined graphics (logo)
 command 67
print station command, set 40
print station parameters command,
 set 43
printer memory allocation defaults 19
proportional 97
proportional font command 25
proportional fonts 97
publications, related xi

R

re-initialize the printer command 51
real-time commands 74
real-time status request command 75
relative position command, set 47
release print buffer 78
release print buffer command 74
request checksum of flash memory
 sector 29
Request document length 40
request printer ID command 15
reset line count 77
reset printer 75
Resetting the printer and the Document
 Sensor Threshold 106
retrieve checksum of each downloaded
 logo or each stored message 29
retrieve flash storage command 73
retrieve size of flash storage
 command 74
return home (select print head
 location) 28, 72
right margin command, set 47
rotated characters command, set or
 cancel 43
RS-232 (EIA-232) commands 5
RS-232 commands summary by
 function 6

S

select character size for scalable fonts 53
select color printing command 44
select maximum print speed 39
select page mode 79
select printable area 79
select printing direction/position 80
select standard mode 79
send status to system command 50
Set document length for landscape
 print 39
set horizontal tabs command 46
set left margin position (standard mode),
 set absolute print position (page
 mode) 81
set printing position 82
set relative horizontal position 81
set relative vertical position 80
set vertical position 80
setting or cancelling rotated
 characters 43
setting print station parameters 43
sheet eject length command, set 45
status byte 1 90
status byte 10 93
status byte 11 93
status byte 12 93
status byte 13 94
status byte 14 94
status byte 15 94
status byte 16 95
status byte 2 90
status byte 3 90
status byte 4 91
status byte 5 91
status byte 6 91
status byte 7 91
status byte 8 92
status byte 9 92
status conditions, summary 89
status information 89
status request command 13
storing a new serial number in the
 firmware 105
strike-through, set, cancel 55
summary of status conditions 89
system commands 13

T

Taiwanese battery recycling
 statement 118
thermal 97
thermal code page command 24
thermal paper, select 55
thermal printing font 97
through, strike, cancel, set 55
trademarks 120

U

underline mode command, set or
 cancel 38
unidirectional printing command, set or
 cancel 39

V

verify previous commands
completed 13

Readers' Comments — We'd Like to Hear from You

SureMark 4610 Printers
Programming Guide
for Models 1xR and 2xR

Publication No. GA27-5005-01

We appreciate your comments about this publication. Please comment on specific errors or omissions, accuracy, organization, subject matter, or completeness of this book. The comments you send should pertain to only the information in this manual or product and the way in which the information is presented.

For technical questions and information about products and prices, please contact your IBM branch office, your IBM business partner, or your authorized remarketer.

When you send comments to IBM, you grant IBM a nonexclusive right to use or distribute your comments in any way it believes appropriate without incurring any obligation to you. IBM or any other organizations will only use the personal information that you supply to contact you about the issues that you state on this form.

Comments:

Thank you for your support.

Send your comments to the address on the reverse side of this form.

If you would like a response from IBM, please fill in the following information:

Name

Address

Company or Organization

Phone No.

Email address



Fold and Tape

Please do not staple

Fold and Tape



NO POSTAGE
NECESSARY
IF MAILED IN THE
UNITED STATES

BUSINESS REPLY MAIL

FIRST-CLASS MAIL PERMIT NO. 40 ARMONK, NEW YORK

POSTAGE WILL BE PAID BY ADDRESSEE

IBM Corporation
Retail Store Solutions Information Development
Department ZBDA
P. O. Box 12195
RESEARCH TRIANGLE PARK NC 27709-9990



Fold and Tape

Please do not staple

Fold and Tape



Printed in USA

GA27-5005-01

