



MODEL G5783 3/8" REVERSIBLE ANGLE AIR DRILL INSTRUCTION SHEET

⚠ WARNING	
	EYE/EAR INJURY HAZARD! Wear safety glasses and hearing protection during use of this tool!
	INJURY HAZARD! Always disconnect tool from air to prevent unexpected operation during service!
	DO NOT EXCEED 120 PSI! Personal injury could occur.



Figure 1. Model G5783.

Introduction

Drill in tight places with this 3/8" reversible angle drill. Producing up to 1300 RPM, this angle drill includes a 3/8" Jacobs® chuck and chuck key. The large paddle switch also makes this drill easy to use in any position. Requires 90 PSI of air pressure with 7 CFM of compressor capacity.

Inventory

- A. Angle Air Drill 1
- B. Chuck Key 1
- C. Hex Wrench 3mm 1

Operation

Insert your drill bit up to 3/8" into the chuck and tighten with the chuck key. Change the drill direction by pushing the reverse valve into the body then rotate to lock into position. Connect the drill to your regulated air source. The hex wrench is included for removing the screw (Ref #55) that holds the chuck to the spindle.

Air drill **MUST** have 3-4 drops of air tool oil directly dropped into the air fitting before each use as shown in **Figure 2**. Keep the head gear lubricated by pumping a small amount light grease into the ball cap on the head.

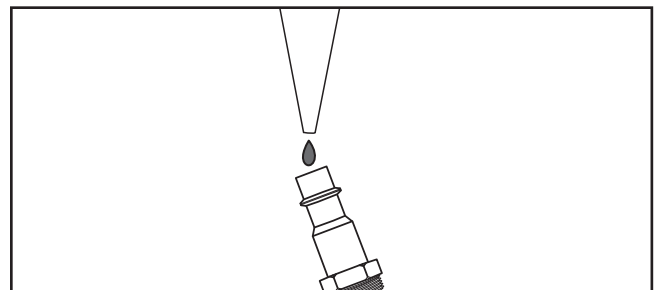

Figure 2. Lubricating directly into air fitting.

If you need help with your new pneumatic tool, call our Tech Support at: (570) 546-9663.

COPYRIGHT © JUNE, 2006 BY GRIZZLY INDUSTRIAL, INC.

WARNING: NO PORTION OF THIS MANUAL MAY BE REPRODUCED IN ANY SHAPE OR FORM WITHOUT THE WRITTEN APPROVAL OF GRIZZLY INDUSTRIAL, INC.

#PC8322 PRINTED IN TAIWAN

G5783 Parts Breakdown and List

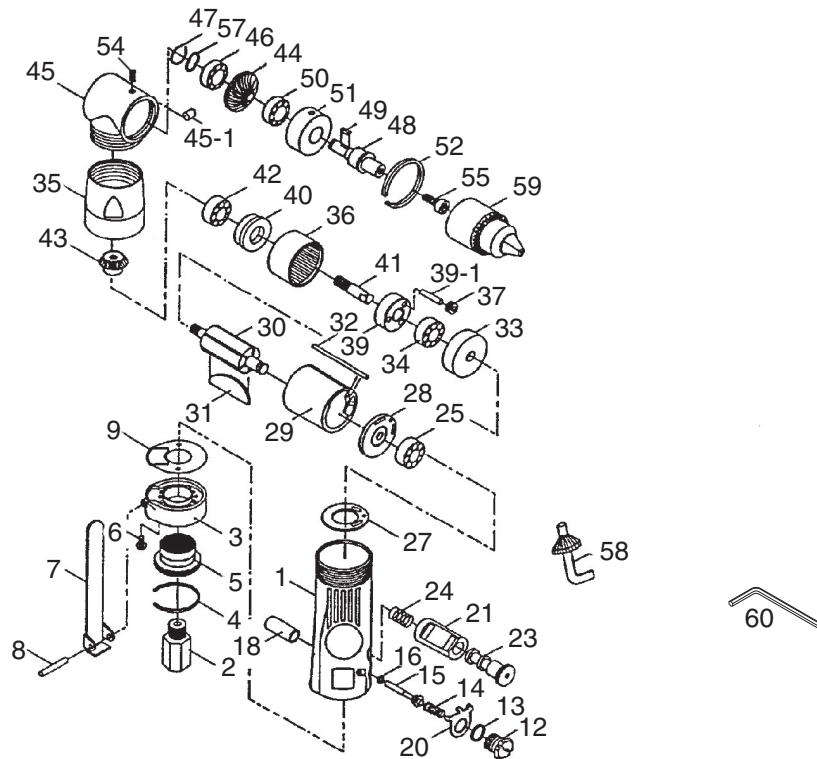

REF	PART #	DESCRIPTION
1	P5783001	MOTOR HOUSING
2	P5783002	AIR INLET
3	P5783003	DEFLECTOR
4	P5783004	STOP RING
5	P5783005	HOUSING CAP
6	P5783006	SCREW
7	P5783007	LEVER
8	P5783008	SPRING PIN
9	P5783009	GASKET
12	P5783012	VALVE SCREW
13	P5783013	O-RING
14	P5783014	VALVE BUSHING
15	P5783015	THROTTLE VALVE
16	P5783016	O-RING
18	P5783018	VALVE BUSHING
20	P5783020	REVERSE RETAINER
21	P5783021	REVERSE BUSHING
23	P5783023	REVERSE VALVE
24	P5783024	REVERSE SPRING
25	P5783025	BALL BEARING
27	P5783027	GASKET
28	P5783028	REAR END PLATE
29	P5783029	CYLINDER
30	P5783030	ROTOR
31	P5783031	ROTOR BLADE
32	P5783032	MOTOR PIN
33	P5783033	FRONT END PLATE

REF	PART #	DESCRIPTION
34	P5783034	BALL BEARING
35	P5783035	LOCK RING
36	P5783036	INTERNAL GEAR
37	P5783037	PLANET GEAR
39	P5783039	CAGE
39-1	P5783039-1	PIN
40	P5783040	SPACER
41	P5783041	GEAR SPINDLE
42	P5783042	BALL BEARING
43	P5783043	PINION
44	P5783044	GEAR
45	P5783045	ANGLE HOUSING
45-1	P5783045-1	BALL CAP
46	P5783046	BALL BEARING
47	P5783047	RETAINER RING
48	P5783048	SPINDLE
49	P5783049	KEY
50	P5783050	BALL BEARING
51	P5783051	BEARING CASE
52	P5783052	RETAINER RING
54	P5783054	SET SCREW
55	P5783055	SCREW
56	P5783056	CHUCK KEY
57	P5783057	WAVE WASHER
58	P5783058	CHUCK KEY
59	P5783059	3/8 DRILL CHUCK
60	PAW03M	HEX WRENCH 3MM