

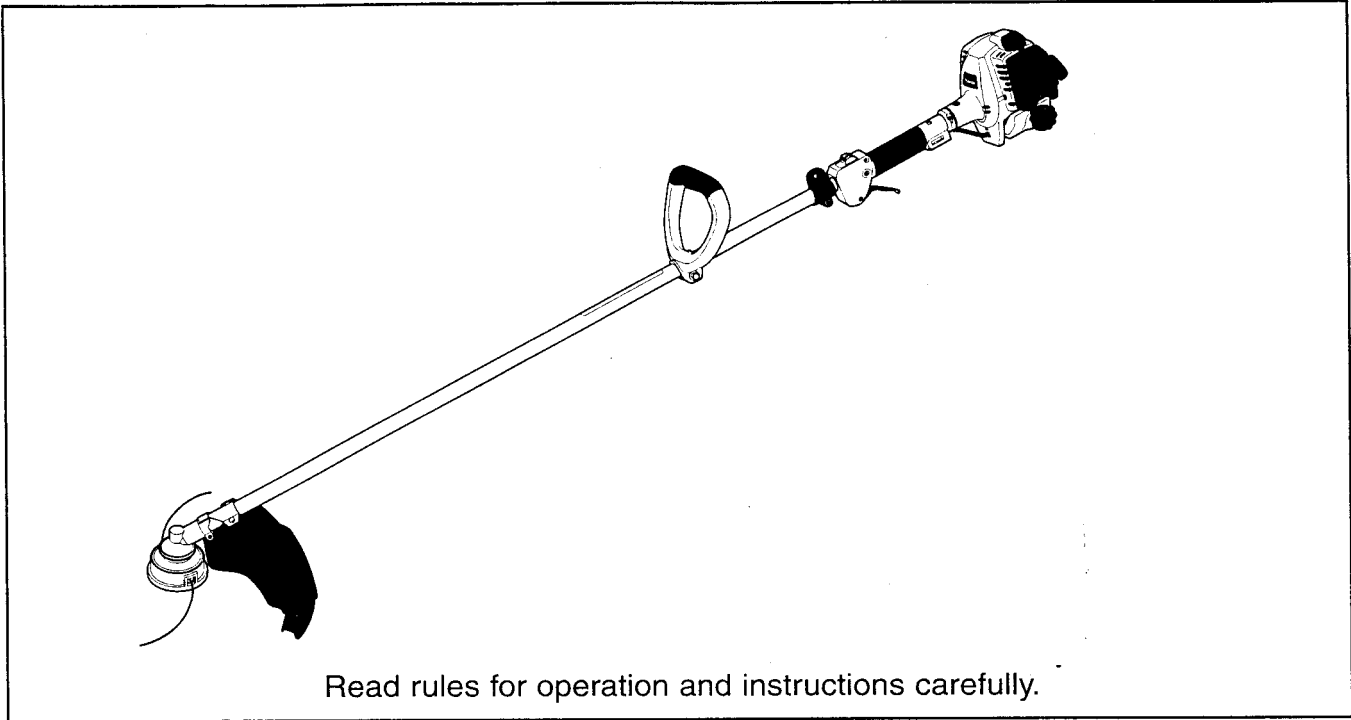

# String Trimmer

**Models: RBC221  
RBC251  
RBC25A**

## INSTRUCTION MANUAL



### SPECIFICATIONS

Model	RBC221	RBC251	RBC25A
Dimensions (mm) (L x W x H)	1,725 x 214 x 238 (67-29/32" x 8-7/16" x 9-3/8")		
Weight (kg)	4.1 (9.0 lbs)		4.3 (9.5 lbs)
Revolution of cutter head (rpm)	4,000 ~ 6,000		
Gear ratio	13/19		
Clutch	Automatic centrifugal type		
Drive Shaft Type	Splined steel shaft		Flexible steel shaft
Engine:			
Displacement (cc)	21.7		24.5
Power rating (ps)	1.0		1.3
Carburetor	All position diaphragm type		
Starting system	Recoil starter		
Ignition system	Solid state ignition		
Spark Plug	NGK BM7A or equivalent		
Fuel tank (l)	0.5 (0.48 quarts)		
Fuel	Mixed gas (Unleaded Gasoline: Genuine Makita Two-cycle Engine Oil = 50 : 1)		

- NOTE:
- **STRING TRIMMERS ARE FOR USE WITH NYLON CUTTING HEADS ONLY. NEVER INSTALL OR USE ANY METAL CUTTER BLADE OR METALLIC CUTTING LINE. SERIOUS LACERATIONS COULD RESULT.**
  - Specifications are subject to change without notice.

Thank you very much for purchasing your MAKITA STRING TRIMMER. We are proud of and very confident in recommending our MAKITA STRING TRIMMER as a result of our extensive development and substantial knowledge and experience.

Please read and understand this booklet thoroughly before operating your MAKITA STRING TRIMMER in order to take advantage of its outstanding performance.

STRING TRIMMERS are designed for trimming grass, weeds and low growth, non-wood ground cover. Always use the proper machine for the job.

## **SAFETY RULES AND PRECAUTIONS**

Proper safety precautions must be observed. Like all power equipment this unit must be handled carefully. **DO NOT EXPOSE YOURSELF OR OTHERS TO DANGER.** Follow these general rules. Do not permit others to use this machine unless they are thoroughly responsible and have read and understood the machine manual and are trained in its operation.

1. Always wear safety goggles for eye protection. Dress appropriately; do not wear loose clothing or jewelry that could become caught in moving parts of the unit. Safe, sturdy, nonskid footwear should always be worn. Long hair should be tied back. It is recommended that legs and feet be covered to protect them from flying debris during operation.
2. Inspect the entire machine for loose parts (nuts, bolts, screws, etc.) and any damage. Repair or replace as necessary before using the machine.
3. **DO NOT USE** any attachment with this power head other than one recommended by MAKITA. Serious injury to the user or bystanders or damage to the engine could result.
4. Keep the handles free of oil and fuel.
5. Always use the proper handle and shoulder strap when cutting.
6. Do not smoke while mixing fuel or filling tank.
7. Do not mix fuel in an enclosed room or near open flames. Assure adequate ventilation.
8. Always mix and store the fuel in a properly marked container that is approved by local codes and ordinances for such usage.
9. Never remove the fuel tank cap while the engine is running.
10. Never start or run the engine inside a closed room or building. Fumes from the exhaust contain dangerous carbon monoxide.
11. Never attempt to make engine adjustments while the unit is running and strapped to the operator. Always make engine adjustments with the unit resting on a flat, clear surface.
12. Do not use the unit if it is damaged or poorly adjusted. Never remove the machine's guard.
13. Inspect the area to be cut and remove all debris that could become entangled in the nylon cutting head. Also remove any objects that the unit may throw during cutting.
14. Keep children away. Onlookers should be kept at a safe distance from the work area, at least 50 feet.
15. Never leave the machine unattended.
16. Do not use this unit for any jobs other than those for which it is intended as described in the manual.
17. Do not overreach. Keep proper footing and balance at all times. Do not run the unit while standing on a ladder or any other unstable footing location.
18. Keep hands and feet clear of the nylon cutting head while the unit is in use.
19. Do not use this type of machine for sweeping away debris.
20. Do not use the unit when you are tired or under the influence of medication, drugs or alcohol.
21. Do not use a damaged cutting head. If a stone or any other obstacle is hit, stop the engine and check the nylon cutting head. A broken or unbalanced nylon cutting head must never be used. Follow instructions for changing accessories.
22. Do not store in a closed area where fuel vapors can reach an open flame from hot water heaters, furnaces, etc. Store in a locked, well ventilated area only.

23. Use only replacement parts that are identical to original equipment parts when servicing the unit; these parts are available from your dealer. The use of any other accessory or attachment may create a potential hazard, injury to the user and damage to the machine.
24. Clean the machine completely, especially the fuel tank cap, its surroundings, and the air cleaner.
25. When refueling, be sure to stop the engine and confirm that it has cooled down. Never refuel when the engine is running or hot. When gasoline spills, be sure to completely wipe it away and properly dispose of those materials before starting the engine.
26. Stay clear of other workers or bystanders.
27. When approaching an operator of the machine, carefully call his attention and confirm that the operator stops the engine. Be careful not to startle or distract the operator causing an unsafe situation.
28. Never touch the nylon cutting head while the engine is running. If it is necessary to adjust the protector or nylon cutting head, be sure to stop the engine and confirm that the nylon cutting head has stopped turning.
29. The engine should be turned off when the machine is moved between work areas.
30. Be careful not to hit the nylon cutting head against stones, or the ground. Unreasonably rough operation will shorten the life of the machine as well as create an unsafe environment for you and those around you.
31. Pay attention to loosening and overheating of parts. If there is any abnormality of the machine, stop operation immediately and check the machine carefully. If necessary, have the machine serviced by a qualified service facility. Never continue to operate a machine which may be malfunctioning.
32. In startup or during operation of the engine, never touch hot parts such as the muffler, the high-voltage wire or the spark plug.
33. For a while after the engine has stopped, the muffler is still hot. Never place the machine near flammable materials (dry grass, etc.), combustible gasses or combustible liquids.
34. Pay special attention when operating in the rain or shortly after the rain as the ground may be slippery.
35. If you slip or fall to the ground or into a hole, release the throttle lever immediately.
36. Be careful not to drop the machine or hit it against obstacles.
37. Before proceeding to adjust or repair the machine, be sure to stop the engine and detach the spark plug cap from the spark plug.
38. Before storing the machine for a long time, drain all fuel from the fuel tank and carburetor, clean the parts, move the machine to a safe place, and confirm that the engine has cooled down.
39. Make periodic inspections to assure safe and efficient operation, If you need professional inspection of your machine, please contact your nearest Makita Factory Service Center or authorized dealer.
40. Keep the machine well away from fire or sparks.
41. Warning: The cutter area is dangerous while the machine is coasting to a stop.
42. Don't try to tackle a big job with an undersized machine. Use this machine only for trimming; use a lawn mower for large areas.
43. Wear a dust mask in dusty work conditions.
44. Wear hearing protection for extended periods of use, and any time the noise is uncomfortable.
45. Keep guards and protectors in place and in working order.
46. Never operate this machine while it is turned upside-down or when it is at an extreme angle.

**CAUTION!**

**CAUTION!**

**CAUTION!**

**WHEN MIXING GASOLINE WITH TWO-CYCLE ENGINE OIL, USE ONLY GASOLINE WHICH CONTAINS NO ETHANOL OR METHANOL (TYPES OF ALCOHOL), THIS WILL HELP TO AVOID POSSIBLE DAMAGE TO ENGINE FUEL LINES AND OTHER ENGINE PARTS.**

**SAVE THESE INSTRUCTIONS.**

# EQUIPMENT DESCRIPTION

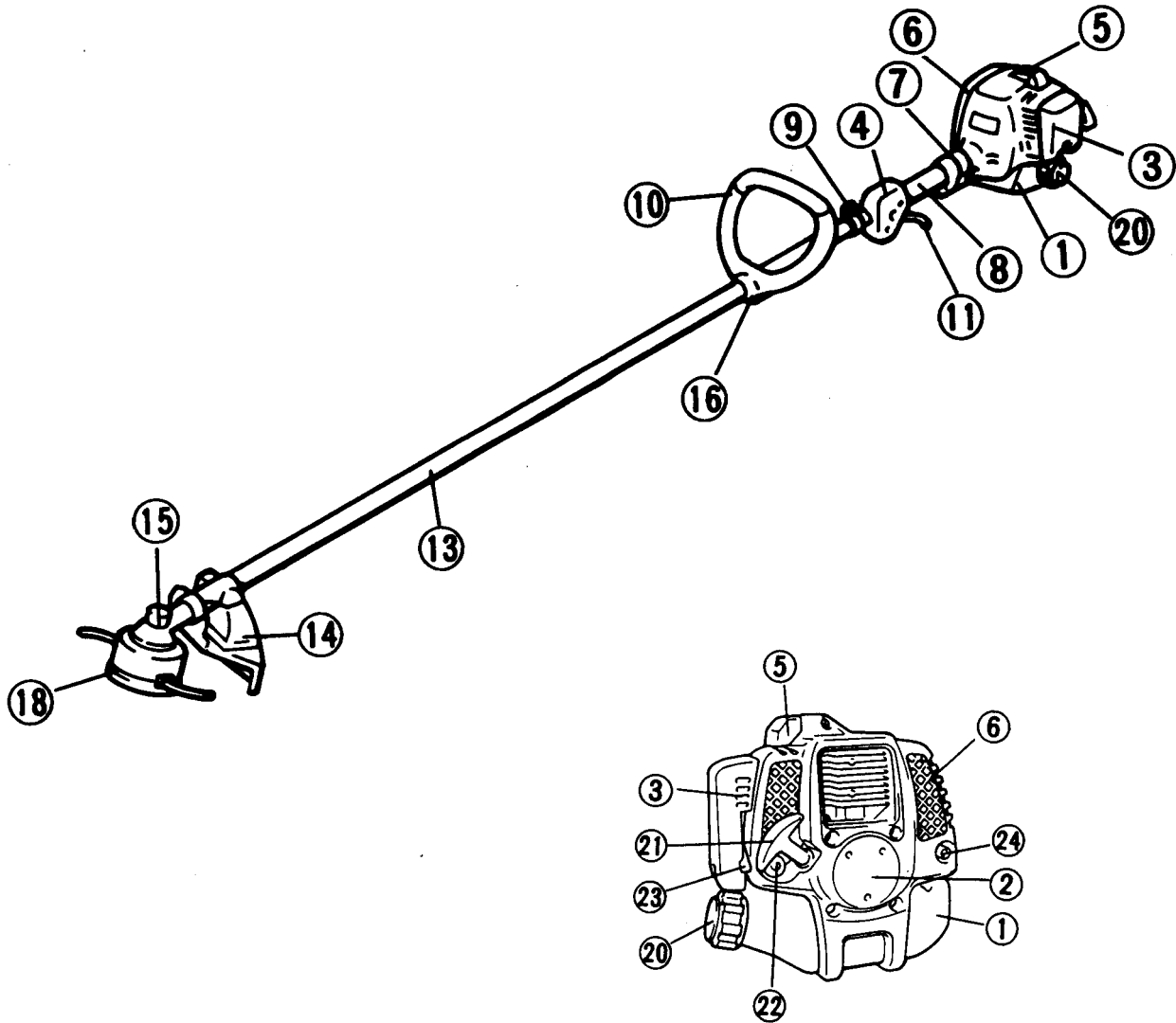

ITEM NO.	DESCRIPTION	ITEM NO.	DESCRIPTION	ITEM NO.	DESCRIPTION
1.	Fuel Tank	8.	Rear Grip	16.	Handle Joint
2.	Recoil Starter	9.	Hanger	18.	Nylon Cutting Head
3.	Air Cleaner	10.	Handle	20.	Fuel Filler Cap
4.	Stop Switch	11.	Throttle Lever	21.	Starter Knob
5.	Spark Plug	13.	Drive Shaft	22.	Primer Pump
6.	Muffler	14.	Protector	23.	Choke Lever
7.	Holder case	15.	Gear Case	24.	Exhaust Pipe

# ASSEMBLY INSTRUCTIONS

## Mounting the handle (Fig. 1)

1. Attach the handle to the drive shaft.
2. Install the handle joint on the handle as shown in Fig. 1.
3. Insert the installation bolt M6x45 through the holes in the handle, and attach the flange nut M6.
4. Adjust the handle to the desired position and tighten the installation bolt.

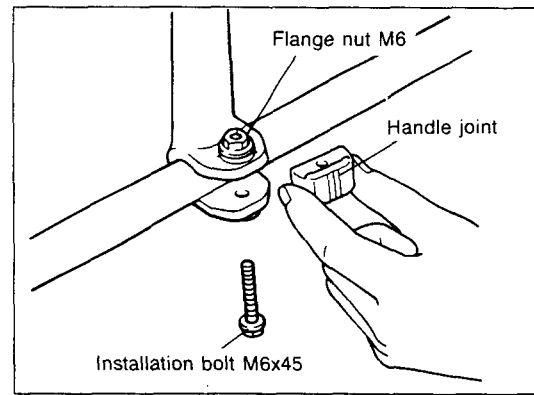

Fig. 1

## Mounting the protector (Fig. 2)

1. Install the clamp on the drive shaft so that the projection of the clamp is inserted into the opening between the gear case and the drive shaft.
2. Attach the protector with two installation bolts M6x20.

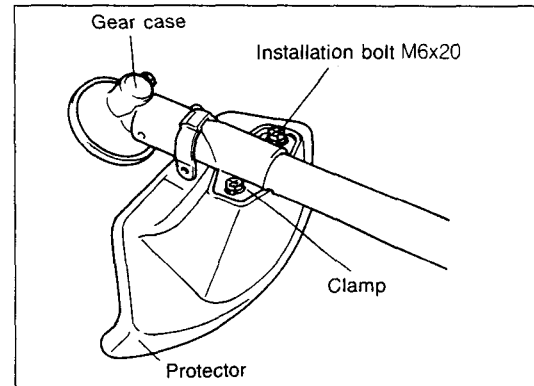

Fig. 2

## Mounting the nylon cutting head

1. Turn the machine upside down so that you can easily install the nylon cutting head.
2. Insert the hex wrench through the hole in the gear case, and turn the support washer until it is locked with the hex wrench (or the shaft is locked).
3. Using the socket wrench, remove the left-handed nut (by turning it clockwise). Also remove the tightening washer (Fig. 3).
4. Screw the nylon cutting head onto the shaft (Fig. 4).

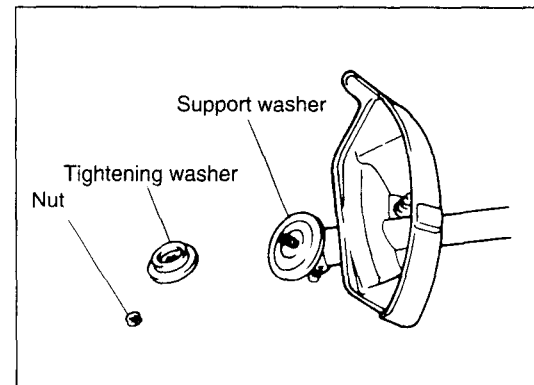

Fig. 3

## IMPORTANT!

**READ THE INSTRUCTIONS FOR USE OF THE NYLON CUTTING HEAD (PAGE 11) BEFORE OPERATING THIS MACHINE.**

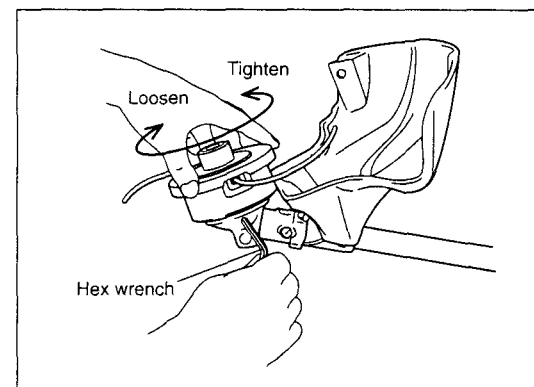

Fig. 4

## **PREPARING FOR OPERATION**

### **Fuel and oil mixture**

Inspect the fuel tank and fill with clean, fresh fuel of the proper mixture to assure the longer life of the tool. Use the following mixed gas.

Gasoline : Genuine Makita Two-cycle engine oil = 50 : 1 or

Gasoline : Other manufacturer's Two-cycle engine oil = 25 : 1 recommended

---

### **FOR CALIFORNIA REGULATION:**

**THIS EQUIPMENT IS CERTIFIED TO OPERATE ON GASOLINE + TWO-CYCLE ENGINE OIL**

---

WHEN MIXING GASOLINE WITH TWO-CYCLE ENGINE OIL, USE ONLY GASOLINE WHICH CONTAINS NO ETHANOL OR METHANOL (TYPES OF ALCOHOL). THIS WILL HELP TO AVOID POSSIBLE DAMAGE TO ENGINE FUEL LINES AND OTHER ENGINE PARTS.

DO NOT MIX GASOLINE AND OIL DIRECTLY IN THE FUEL TANK.

**IMPORTANT: Failure to follow proper fuel mix instructions may cause damage to the engine.**

### **CAUTION:**

1. When preparing fuel mixture, mix only the amount needed for the job you are to do. Do not use fuel mixture that has been stored longer than two months. Fuel mixture stored longer than this will cause hard starting and poor performance. If fuel mix has been stored longer than this time, it should be removed and replaced with a fresh mixture.
2. Never fill the fuel tank to the very top.
3. Never add fuel to the tank in a closed, unventilated area.
4. Do not add fuel to this unit close to an open fire or sparks.
5. Be sure to wipe off spilled fuel before attempting to start the engine.
6. Do not attempt to refuel a hot engine.



### **Check points before operation**

1. Check for loose bolts, nuts and fittings.
2. Check the air cleaner for dirt. Clean the air filter of all dirt, etc. before operation.
3. Check to be sure that protector is securely in place.

# ENGINE STARTING AND STOPPING PROCEDURES

## Starting when the engine is cold

Use the following procedure when the engine is cold, or after it has been stopped for longer than 5 minutes, or after fuel has been added to the engine:

1. Slide the stop switch away from the "STOP" position (Fig. 5).
2. Gently push on the primer pump repeatedly (7 - 10 times) until fuel enters the primer pump (Fig. 6).
3. Close the choke lever fully by moving it to the  position (Fig. 6).
4. Lock the throttle lever in the "start" position as follows:
  - i). Squeeze the throttle lever fully.
  - ii). Hook the lock fin to the notch in the throttle lever case while releasing the throttle lever (Fig. 7).
5. Place the machine on the ground. Hold the drive shaft or the grip with one hand, and give several strong pulls to the starter using the other hand.
6. After the engine has started, open the choke lever fully by moving it gradually to the  position.
7. Release the throttle lever fully.  
**Note:** The throttle lever is unlocked by squeezing it slightly.

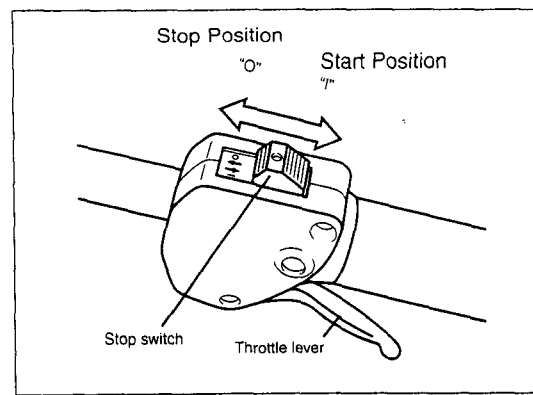

Fig. 5

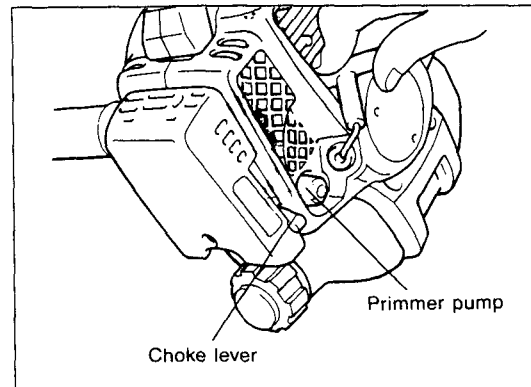



Fig. 6

## Restarting immediately after the engine has stopped.

1. Slide the stop switch away from the "STOP" position (Fig. 5).
2. Gently push on the primer pump repeatedly (7 - 10 times) until fuel enters the primer pump (Fig. 6).
3. Leave the choke lever in the open  position (Fig. 6).
4. Leave the throttle lever fully released.
5. Place the machine on the ground. Hold the drive shaft or grip with one hand, and give several strong pulls to the starter using the other hand.

### CAUTION:

Never operate the engine at high rpm without load. With the throttle lever fully squeezed and no load, the engine rpm will be very high which could have an adverse effect on the life of the engine.

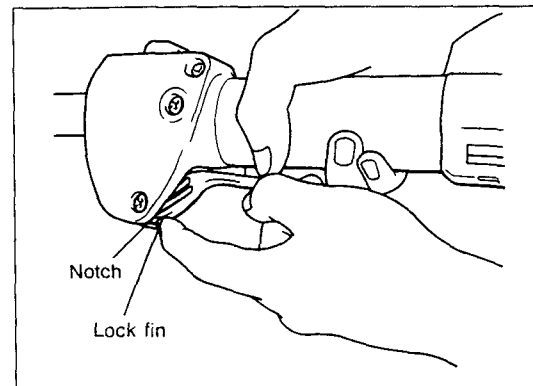

Fig. 7

## Stopping

1. Release the throttle lever fully.
2. When the engine rpm has lowered, push the stop switch to the "STOP" position. The engine will stop.

## Idle adjustment

The nylon cutting head should not run when the throttle lever is fully released. If necessary, adjust the idle rpm using the idle adjusting screw (Fig. 8).

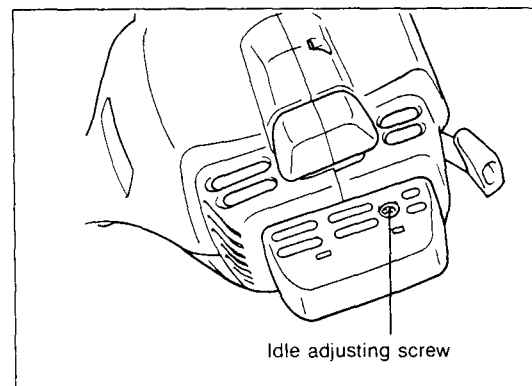

Fig. 8

## CORRECT HANDLING OF THE MACHINE



Fig. 9

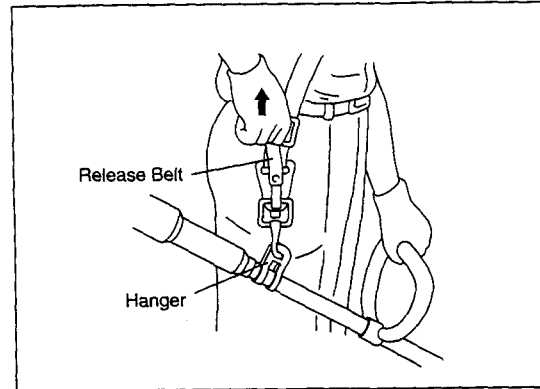

Fig. 10

### Attachment, adjustment and detachment of the shoulder strap

#### Attachment

Place the strap hook into the hanger which is located on the shaft between the grip and the handle.

#### Adjustment

Adjust the strap length so that the nylon cutting head will be kept parallel to the ground (Fig. 9).

#### Detachment (NORMAL)

Remove the strap hook from the hanger.

#### Detachment (EMERGENCY)

In an emergency, release the throttle lever, firmly pull the release belt upward and detach the machine from you (Fig. 10). Be extremely cautious to maintain control of the machine at this time. Do not allow the machine to be deflected toward you or anyone in the work vicinity.

#### WARNING:

**Failure to maintain complete control of the machine at all times could result in serious bodily injury or DEATH.**

#### Notes:

The shoulder strap has a quick release system. Check that the hook is assembled as shown in Fig. 11. If it is not, remove it and reassemble it as shown. (Fig. 11)

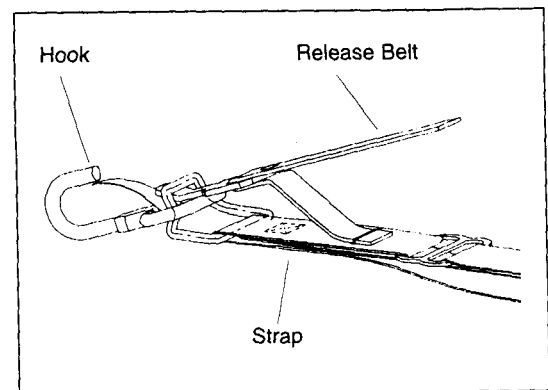

Fig. 11

### Handling the machine

1. Hang the machine on the right side of your body.
2. Squeeze the throttle lever to increase the rotational speed. Release the throttle lever and the engine will run at idle (low speed). Use a rotational speed suitable for the grass being cut. If the rotational speed is excessively low, grass may become jammed in the nylon cutting head.
3. During grass cutting, firmly hold the machine to allow easy, controlled handling.
4. Never strike or tap objects with the nylon cutting head.



## DAILY CHECK-UP AND MAINTENANCE

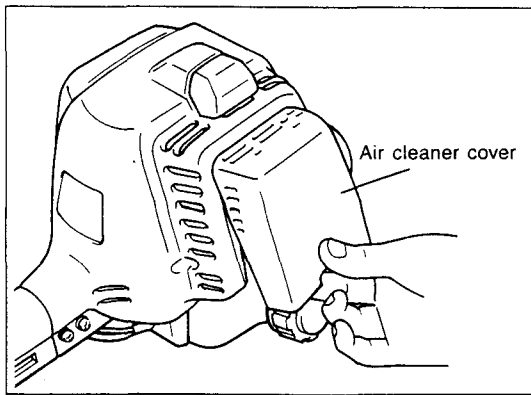

Fig. 12

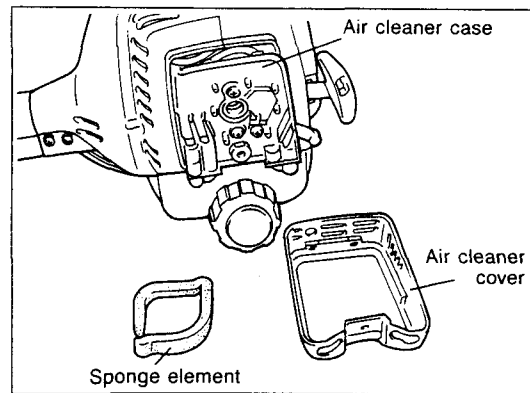

Fig. 13

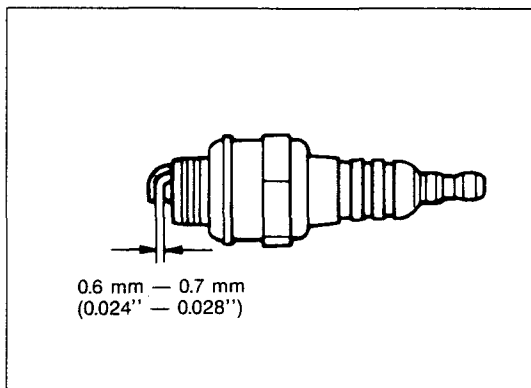

Fig. 14

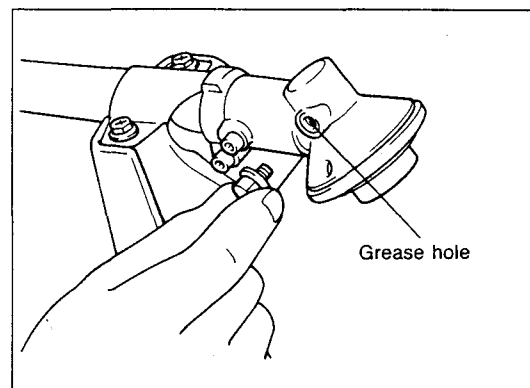

Fig. 15

1. Before operation, pay particular attention to the tightness of the nylon cutting head. Re-tighten the nylon cutting head if necessary (every 8 hours or daily).
2. Check for clogged cooling air passage and cylinder fins. Clean them if necessary (every 8 hours or daily).
3. Clean the air cleaner every 8 hours or daily, using the following procedure:
  - i). Remove the air cleaner cover. Clean the sponge element and remove any excessive dust or dirt adhering to the cleaner (Fig. 12 and 13). A clogged air cleaner may make it difficult or impossible to start the engine or to increase the engine rotational speed
  - ii). Re-install the sponge element around the ribs of the air cleaner case.
4. Check the spark plug every 8 hours or daily.  
The gap between the two electrodes of the spark plug should be 0.6 to 0.7 mm (0.024" to 0.028").  
If the gap is too wide or too narrow, adjust it.  
If the spark plug is clogged with carbon or fouled, clean it thoroughly or replace it (Fig. 14).
5. Apply grease (SHELL ALVANIA No. 3 or equivalent) to the gear case through the grease hole every 30 hours (Fig. 15).
6. **FOR RBC25A ONLY**  
Apply grease (SHELL ALVANIA No. 2 or equivalent) to the flexible shaft every 50 hours.
  - i). Pull the gear case from the drive shaft after removing bolts.
  - ii). Pull the flexible shaft out of the drive shaft housing. Apply grease to the drive shaft.
7. Clean the muffler exhaust port every 50 hours or monthly.
8. Check the fuel filter. If clogged, replace it with a new one every 50 hours or monthly.
9. Replace the fuel lines every 200 hours or yearly.
10. Overhaul the engine every 200 hours or yearly.
11. Replace the packing and gaskets with new ones every time the engine is reassembled.

## STORAGE

When storing the machine for a long time, drain the fuel from the fuel tank and carburetor as follows:

1. Drain all fuel from the fuel tank. Gently push on the primer pump repeatedly until all fuel is expelled out of the primer pump. Properly dispose of the fuel in accordance with all local laws.
2. Remove the spark plug and add a few drops of oil into the spark plug hole. Then, pull the starter gently to assure that an oil film coats the engine inside, then insert and tighten the spark plug.
3. Clear or blow any dirt or dust from the nylon cutting head and engine housing; wipe them with an oil-immersed cloth and store the machine in a dry location.

## REASSEMBLY INSTRUCTIONS

### Reassembling the drive shaft and the engine.

The shaft and the engine on this machine have been assembled in the factory. If you remove the shaft (example, for maintenance) carefully reassemble it as shown below:

1. Loosen the screws M5x18 and insert the drive shaft into the holder case (Fig. 16).  
Note:
    - i). Always insert the drive shaft into the holder case fully (approx. 60mm; 2-3/8"). If the inner shaft resists full insertion of the drive shaft, try to insert it again while slightly rotating the support washer on the gear case.
    - ii). Be cautious not to allow the switch cords to be pinched between the holder case and the grip end.
  2. After making sure that the drive shaft is installed fully and properly, tighten the screws M5x18 to secure the drive shaft.
  3. Insert the nipple of the throttle wire through the square hole in the grip until it fits into an inner square hole in the moving part which is inside the grip. The nipple should move when the throttle lever is squeezed (Fig. 17).
4. Connect the two switch wires to the engine wires by inserting one into the other.
  5. Cover the throttle wire and switch wires with split tubing.

#### Note:

It is easier to install the split tubing if the bullet connectors are partially pushed into the motor cover to remove slack from the wires (Fig. 18).

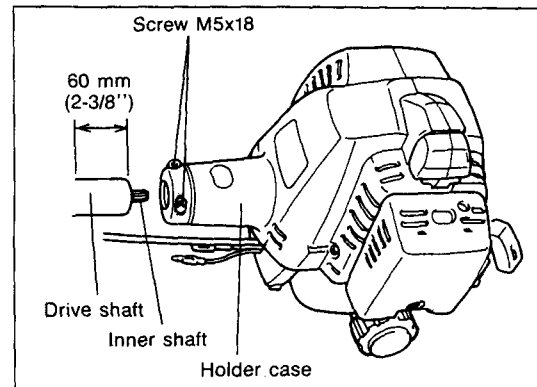

Fig. 16

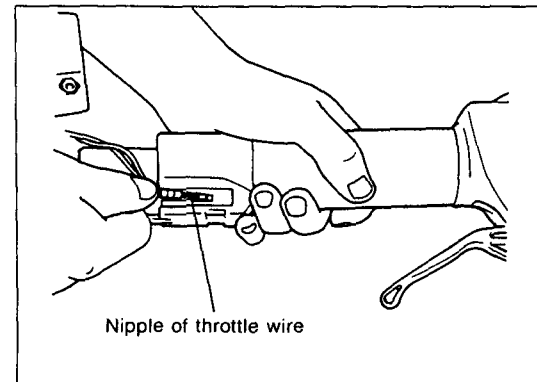

Fig. 17

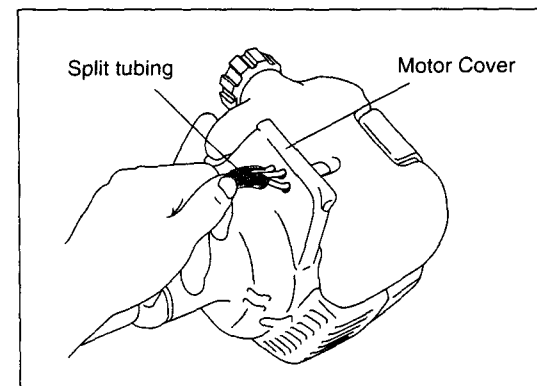

Fig. 18

# INSTRUCTIONS FOR USE OF THE NYLON CUTTING HEAD (BUMP & FEED BF4)

## Safety Instructions

1. Read this section carefully and thoroughly before use.
2. Check the nylon cutting head carefully before each use. If you notice any of following, replace the worn or damaged parts with new ones immediately (Fig. 19):
  - Dents appear on the knob head.
  - The housing (cover) is damaged or cracked.
  - The "Limit marks (notches)" on the cover have disappeared.
3. Wear appropriate clothing and protectors.
4. Always stop the engine before inspecting the cutting head BF4 or replacing the nylon cord.
5. Do not allow anyone near the operation area. The cutters might send stones or debris flying, possibly harming bystanders.
6. Never use the cutting head BF4 on tools with a cutter head speed higher than 10,000 RPM.

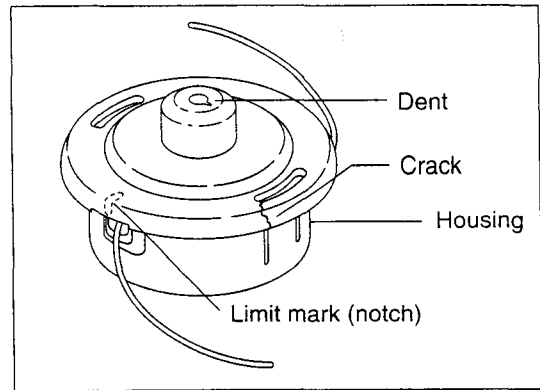

Fig. 19

## Installation

See page 5 (Mounting the nylon cutting head)

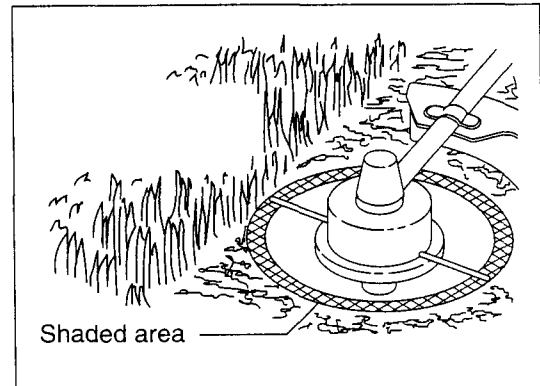

Fig. 20

## Operation

1. Increase the cutter head speed to approx. 6,000 RPM. Low speed (under 4,000 RPM) causes inefficient cutting. Use the tip of the nylon cord (shaded area shown in Fig. 20) for more effective cutting.
2. When the nylon cord wears down (becomes short), decrease the engine speed to under 4,000 RPM and bump the knob of the nylon cutting head against the ground to feed out the nylon cord (Fig. 21).

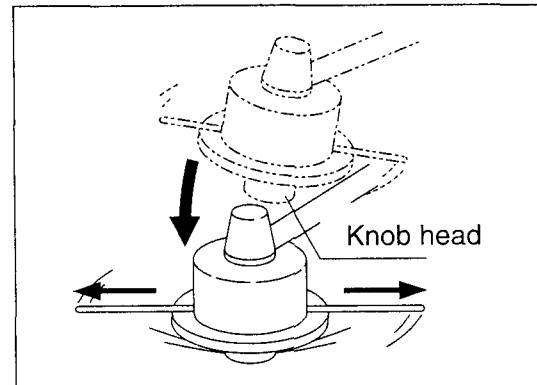

Fig. 21

## Parts Breakdown

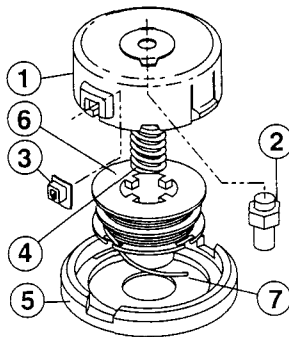

Fig. 22

ITEM	DESCRIPTION	PART NO.
1.	Housing	B-03034
2.	Attachment nut	B-03040
3.	Eyelet	A-15992
4.	Spring	B-03056
5.	Cover	B-60159
6.	Spool (with .095" x 20 ft Nylon cord installed)	B-01971
7.	Nylon cord	-----
OPTIONAL NYLON CORDS	Nylon cord .095" x 16.4 ft	B-01971
	Nylon cord .095" x 1/2 lb	713302-A
	Nylon cord .095" x 1 lb	713303-A
	Nylon cord .095" x 3 lb	713304-A
	Nylon cord .095" x 5 lb	713305-A

## Replacing the nylon cord

1. Press the housing latches inward to lift off the cover; then remove the spool (Fig. 23).
2. Run the new nylon cord through the hole in the center of the spool, and pass one end of the cord through the notch into the other side of the spool. Allow one end of the cord to extend about 3" (80 mm) further than the other end (Fig. 24).
3. Wind both ends firmly around the spool in the direction of the head rotation (Fig. 25).
4. Wind all but about 4" (100 mm) to 6" (150 mm) of the cord, leaving the ends temporarily hooked through a notch on the side of the spool (Fig. 26).
5. Mount the spool in the housing so that the grooves and protrusions on the spool are aligned with those in the housing.
6. Unhook the ends of the cord from their temporary position and feed the cords out through the eyelets in the side of the housing (Fig. 27).
7. Align the protrusions on the underside of the cover with the slots of the eyelets. Then push the cover firmly onto the housing to secure it (Fig. 28).

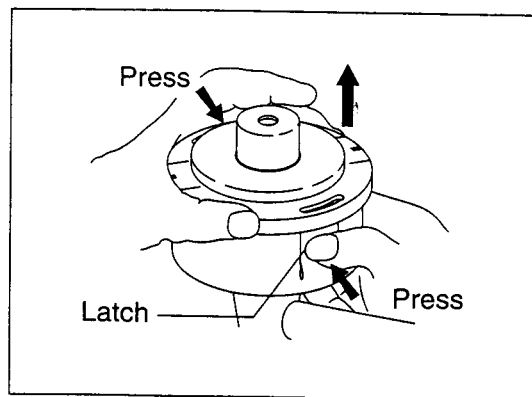

Fig. 23

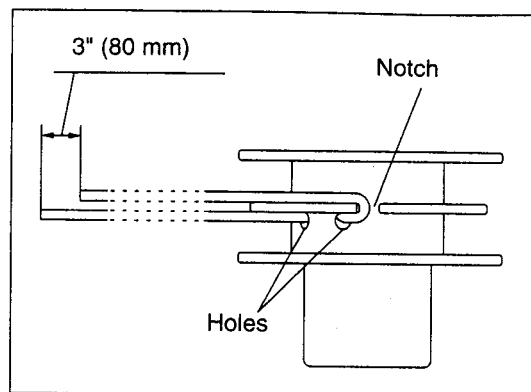

Fig. 24

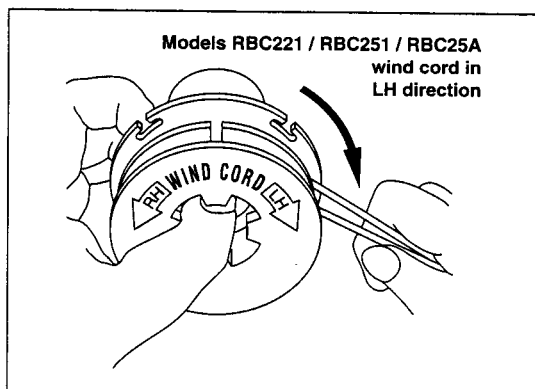

Fig. 25

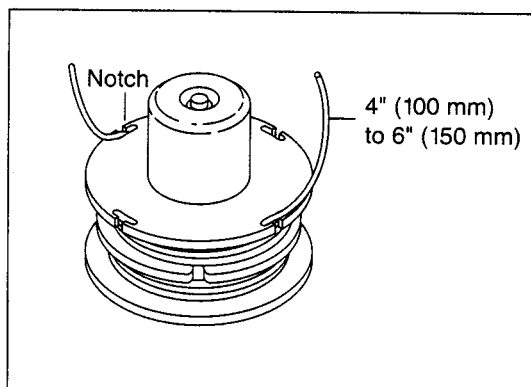

Fig. 26

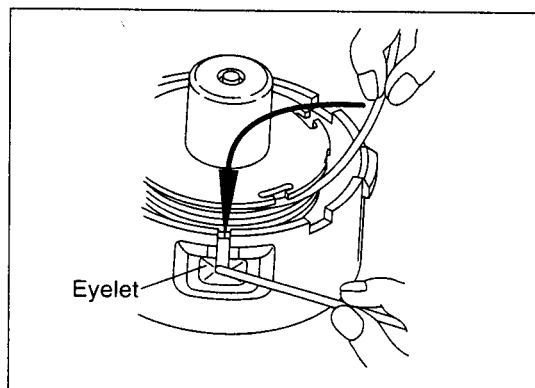

Fig. 27

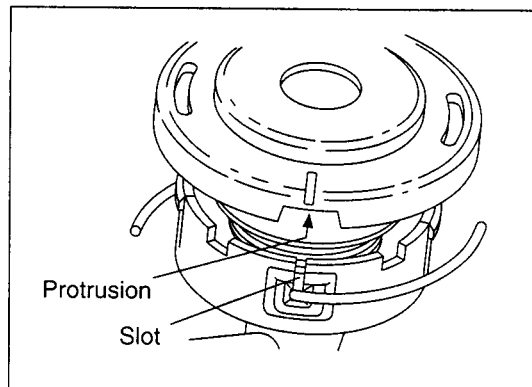

Fig. 28

# Emission Control Warranty Statement

## YOUR WARRANTY RIGHTS AND OBLIGATIONS

*The California Air Resources Board and Makita U.S.A., Inc. are pleased to explain the emission control warranty on your 1995 and later utility and/or lawn and garden equipment engine. In California, new utility and lawn and garden equipment engines must be designed, built and equipped to meet the State's stringent anti-smog standards. Makita U.S.A., Inc. must warrant the emission control system on your utility and/or lawn and garden equipment engine for the periods of time listed below provided there has been no abuse, neglect or improper maintenance of your utility and/or lawn and garden equipment engine.*

*Your emission control system includes parts such as the carburetor or fuel injection systems, the ignition system and the catalytic converter. Also included are the hoses and connectors and other emission-related assemblies.*

*Where a warrantable condition exists, Makita U.S.A., Inc. will repair your utility and/or lawn and garden equipment at no cost to you including diagnosis, parts and labor.*

### **MANUFACTURER'S WARRANTY COVERAGE:**

*The 1995 and later utility and/or lawn and garden equipment engines are warranted for two years. If any emission-related part on your engine is defective, the part will be repaired or replaced by Makita U.S.A., Inc.*

### **OWNER'S WARRANTY RESPONSIBILITIES:**

*As the utility and lawn and garden equipment engine owner, you are responsible for the performance of the required maintenance listed in your owner's manual. Makita U.S.A., Inc. recommends that you retain all receipts covering maintenance on your utility and/or lawn and garden equipment engine, but Makita U.S.A., Inc. cannot deny warranty solely for the lack of receipts or for your failure to ensure the performance of all scheduled maintenance.*

*As the utility and/or lawn and garden equipment engine owner, you should be aware, however, that Makita U.S.A., Inc. may deny you warranty coverage if your utility and/or lawn and garden equipment engine or a part has failed due to abuse, neglect, improper maintenance or unapproved modifications.*

*You are responsible for presenting your utility and/or lawn and garden equipment engine to a Makita U.S.A., Inc. service center as a problem exists. The warranty repairs should be completed in a reasonable time, not to exceed 30 days.*

*If you have any questions regarding your warranty rights and responsibilities, you should contact a Makita Factory Service Center Manager nearest you. A list of the Factory Service Center locations and phone numbers is provided below for your convenience.*

## LIMITED WARRANTY

- California Only -

Makita U.S.A., Inc., a distributor of utility and lawn and garden equipment in the U.S., warrants to the owner of 1995 and later utility and/or lawn and garden equipment engines that the engine (1) has been designed, built, and equipped at the time of manufacture so as to conform with the applicable regulations of the California Air Resources Board, and (2) is free from defects in materials and workmanship which may cause it to fail to conform with those regulations as applicable according to the terms and conditions stated below.

### WARRANTY PERIOD

The warranty period begins on the date which the utility and/or lawn and garden equipment engine is delivered to the original retail purchaser and ends two years after that date. During this two year period Makita U.S.A., Inc. warrants to the original retail purchaser and each subsequent purchaser that the engine is free from defect in material and workmanship that can cause the failure of a warranted emission-related part.

### WHAT IS COVERED UNDER THIS WARRANTY

Repair and/or replacement of any warranted emission-related part will be performed at no charge provided the work is performed at an authorized warranty station. There will also be no charge for any diagnostic labor performed at an authorized warranty station which leads to the determination that a warranted emission-related part is defective.

Any warranted part which is not scheduled for replacement as required maintenance, or which is scheduled only for regular inspection to the effect of "repair or replace as necessary" shall be warranted for the warranty period. Any warranted part which is scheduled for replacement as required maintenance shall be warranted for the period of time up to the first scheduled replacement of that part. This warranty shall apply only towards the repair, replacement, and/or adjustment of the component parts listed below.

### EMISSION-RELATED PARTS COVERED UNDER THIS WARRANTY

1. Fuel Metering Systems
  - (a) Carburetor and its internal parts
  - (b) Air cleaner plate
  - (c) Air cleaner case
  - (d) Air cleaner element
  - (e) Fuel filter
  
2. Ignition Systems
  - (a) Spark Plug
  - (b) Flywheel Magneto
  - (c) Ignition Coil
  
3. Other Miscellaneous Items Used in Above Systems
  - (a) Fuel Hoses
  - (b) Sealing Gaskets

If it is determined by an authorized warranty station that other engine components have been damaged due to the failure of a warranted emission-related part during the warranty period, Makita U.S.A., Inc. will repair and/or replace the necessary components.

## WHAT IS NOT COVERED UNDER THIS WARRANTY

This warranty does not cover any emission-related part which malfunctions, fails, or is damaged due to alterations and/or modifications such as changing, adding, or removing parts.

When an engine is being serviced under warranty, Makita U.S.A., Inc. and any of its authorized dealers, distributors, or warranty stations shall not be liable for any loss of use of the engine, for any damage to goods, or loss of time or inconvenience.

This limited warranty also does not apply to any emission-related part which malfunctions, fails, or is damaged due to failure to follow the maintenance and operating instructions specified in the 1995 and later Owner's Manual including:

- (a) Improper or inadequate maintenance of any warranted emission-related part.
- (b) Improper installation, adjustment, or repair of the engine or any warranted emission-related part unless performed by a factory authorized warranty station.
- (c) Failure to use recommended fuel as specified in the 1995 and later Owner's Manual.
- (d) Repairs and diagnosis performed outside of an authorized warranty station.
- (e) Use of parts which are not authorized by Makita U.S.A., Inc.

## MAINTENANCE SCHEDULE

The engine owner is responsible for having all scheduled inspection and maintenance services performed at the intervals specified in the 1995 and later Owner's Manual and to retain records of these services as having been performed. These records should be transferred to each subsequent owner of the engine. Makita U.S.A., Inc. cannot deny a claim solely because there are no records of scheduled maintenance; however, a warranty claim may be denied if the failure to perform the scheduled maintenance; however, a warranty claim may be denied if the failure to perform the scheduled maintenance and inspection resulted in the failure of a warranted emission-related part. As a minimum, the engine owner is responsible for the scheduled inspection and maintenance described below which are based on the procedures described in the Owner's Manual.

### PROCEDURE

- (a) Check all nuts and bolts and tighten as necessary.
- (b) Check air passages and engine cylinder fins for clogging  
Remove all obstructions as necessary.
- (c) Clean the air cleaner.
- (d) Check the spark plug. Clean and adjust it if necessary.
- (e) Check the muffler exhaust port. Clean it if necessary.
- (f) Check the fuel filter. If clogged, replace it with a new filter.
- (g) Replace fuel lines.
- (h) Overhaul the engine.
- (i) Replace the packings and gaskets.

### INTERVAL

- Every 8 hours of use or daily.
- Every 8 hours of use or daily.
- Every 8 hours of use or daily.
- Every 8 hours of use or daily.
- Every 50 hours of use or monthly.
- Every 50 hours of use or monthly.
- Every 200 hours of use or yearly.
- Every 200 hours of use or yearly.
- Every time the engine is reassembled.

## REPAIR AND REPLACEMENT OF EMISSION-RELATED PARTS

It is recommended that only engine replacement parts which have been authorized and approved by Makita U.S.A., Inc. should be used in the performance of any warranty maintenance or repairs of emission-related parts. These replacement parts will be provided at no charge if the part is still under warranty.

### HOW TO FILE A WARRANTY CLAIM AND WHERE TO GET WARRANTY SERVICES

Contact the nearest Makita Factory Service Center Manager to determine the appropriate location where the required warranty services are to be performed. A list of the Factory Service Center locations and phone numbers are provided below for your convenience.

14930 Northam Street  
La Mirada, CA 90638-5753  
(714) 522-8088

1421 N. Clovis Ave., Ste. 112  
Fresno, CA 93727  
(209) 252-5166

392 S. Arrowhead Ave., #A-1  
San Bernardino, CA 92408  
(909) 885-1289

1714 E. McFadden Ave., Unit M  
Santa Ana, CA 92705  
(714) 667-5066

16735 Saticoy St., Ste. 105  
Van Nuys, CA 91406  
(818) 782-2440

41850 Christy Street  
Fremont, CA 94538-5107  
(510) 657-9881

4554 Roseville Rd., Ste. E  
North Highlands, CA 95660  
(916) 331-6211

7674 Clairemont Mesa Blvd.  
San Diego, CA 92111  
(619) 278-4471

333 Littlefield Ave.  
S. San Francisco, CA 94080  
(415) 875-1002



**WARNING:** The Engine Exhaust from this product contains chemicals known to the State of California to cause cancer, birth defects or other reproductive harm.

**Makita Corporation of America**  
2650 Buford Hwy  
Buford, Georgia 30518