

# USER MANUAL

---

## MODEL 460RC Rack-Mounted G.703 Coax to Twisted Pair Adapters (BALUNs)



**PATTON**  
**Electronics Co.**



An ISO-9001  
Certified Company

Part # 07M460RC-A  
Doc. #019081UA  
Revised 3/13/98

SALES OFFICE  
(301) 975-1000  
TECHNICAL SUPPORT  
(301) 975-1007  
<http://www.patton.com>

## 1.0 WARRANTY INFORMATION

**Patton Electronics** warrants all Model 460RC components to be free from defects, and will—at our option—repair or replace the product should it fail within one year from the first date of shipment. This warranty is limited to defects in workmanship or materials, and does not cover customer damage, abuse or unauthorized modification. If this product fails or does not perform as warranted, your sole recourse shall be repair or replacement as described above. Under no condition shall **Patton Electronics** be liable for any damages incurred by the use of this product. These damages include, but are not limited to, the following: lost profits, lost savings and incidental or consequential damages arising from the use of or inability to use this product. **Patton Electronics** specifically disclaims all other warranties, expressed or implied, and the installation or use of this product shall be deemed an acceptance of these terms by the user.

### 1.1 CE NOTICE

The CE symbol on your Patton Electronics equipment indicates that it is in compliance with the Electromagnetic Compatibility (EMC) directive and the Low Voltage Directive (LVD) of the Union European (EU). A Certificate of Compliance is available by contacting Patton Technical Support.

### 1.2 SERVICE AND SUPPORT

All warranty and non-warranty repairs must be returned freight prepaid and insured to Patton Electronics. All returns must have a Return Materials Authorization number on the outside of the shipping container. This number may be obtained from Patton Electronics Technical Service at **(301) 975-1007**; <http://www.patton.com>; or, [support@patton.com](mailto:support@patton.com).

**NOTE:** Packages received without an RMA number will not be accepted.

Patton Electronics' technical staff is also available to answer any questions that might arise concerning the installation or use of your Model 460RC. Technical Service hours: **8AM to 5PM EST, Monday through Friday.**

## 2.0 GENERAL INFORMATION

Thank you for your purchase of this Patton Electronics product. This product has been thoroughly inspected and tested and is warranted for One Year parts and labor. If any questions or problems arise during installation or use of this product, please do not hesitate to contact Patton Electronics Technical Support at (301) 975-1007.

### 2.1 FEATURES

- Connects 75 Ohm Dual Coax to 120 Ohm Twisted Pair
- Bi-Directional Signal Conversion According to CCITT G.703
- Data Rates up to **2.048 Mbps**
- Low Profile Design
- Mounts in Standard 19" (48.3 cm) Rack
- No AC Power or Batteries Required
- Male or Female Coax BNC Connectors Available
- Strap Selectable Modular (RJ-45) Pinouts

### 2.2 DESCRIPTION

The **Patton 460R Series** G.703 balun panels match multiple sets of dual 75 ohm coax connections to multiple 120 ohm twisted pair connections. This function allows carriers to provide 120 ohm G.703 service to customers retaining 75 ohm CPE hardware. It also allows carriers who have standardized on 75 ohm coax to provide 120 ohm terminations to their customers (in keeping with European ONP requirements).

Supporting E1 data rates to 2.048 Mbps, the Patton 460-R Series panels bi-directionally match, not only signal impedance, but also the pulse shapes of the signals according to the CCITT G.703 standard. The Patton 460-R Series G.703 balun panels mount in a standard 19" (48.3 cm) rack, and are available with either 1 to 16 modules per rack.

### 3.0 CONFIGURATION

Each Model 460RC/F Module is equipped with four jumpers that you may use to configure several grounding options. This section shows the jumper locations and describes their functions.

#### 3.1 SETTING THE JUMPER STRAPS

There are five configuration jumpers on the back side of the Model 460RC/F printed circuit board. These jumpers are labeled below and on the PC board as “JP1”, “JP2”, “JP3”, “JP4”, and “JP7”. Figure 1, below, shows their positions on the pc board as well as the relative pin numbers on the jumpers.

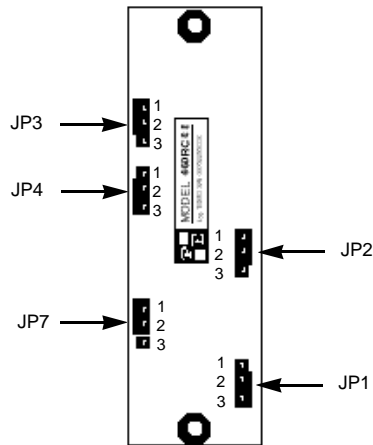

Figure 1. Individual Model 460RC/F Card

Figure 2 (below) shows the orientation of the rear interface card straps. Observe that the strap can either be on posts 1 and 2, or on posts 2 and 3.

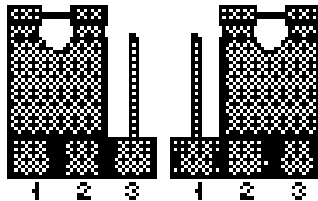

Figure 2. Possible Positions for Model 460RC/F Jumpers

#### 3.1.1 Jumper Straps JP1, JP2, JP3, JP4, and JP7

The jumper straps allow you to set shielding and grounding options for the Model 460RC/F. The settings for each jumper strap are shown briefly in the table below. Following this table are more detailed explanations of each jumper.

INTERFACE CARD STRAP SUMMARY TABLE #1			
Strap	Function	Position 1&2	Position 2&3
JP1	Coax TX Shield & RJ45 Pin 3	Open*	Connected
JP2	Coax TX Shield & RJ-45 Shield	Connected*	Open
JP3	Coax RX Shield & RJ-45 Shield	Connected*	Open
JP4	Coax RX Shield & RJ-45 Pin 6	Open*	Connected
JP7	RJ-45 Shield & Chassis Ground	Connected*	Open

\* Indicates default setting

##### Jumper JP1: 75 Ohm TX Shield to 120 Ohm TX Pair Shield (Pin 3)

In the default “Connected” setting, the 75 Ohm transmit out coaxial shield connects to RJ-45 pin 3, the transmit pair shield.

JP1	Setting	Description
Position 1 & 2	Not Connected	75 Ohm TX shield not connected to RJ-45 TX pair shield (Pin 3).
Position 2 & 3	Connected	75 Ohm TX shield connected to RJ-45 TX pair shield (Pin 3).

##### Jumper JP2: 75 Ohm Shield to 120 Ohm Overall Shield

In the default “Connected” setting, the 75 Ohm transmit out coaxial shield connects to the RJ-45 overall foil shield.

JP2	Setting	Description
Position 1 & 2	Connected	75 Ohm TX shield connected to the RJ-45 overall foil shield.
Position 2 & 3	Not Connected	75 Ohm TX shield not connected to the RJ-45 overall foil shield.

## 4.0 INSTALLATION

### Jumper JP3: 75 Ohm RX Shield to 120 Ohm Overall Shield

In the default “Connected” setting, the 75 Ohm receive in coaxial shield connects to RJ-45 pin 6, the receive pair shield.

JP3	Setting	Description
Position 1 & 2	Connected	75 Ohm RX shield connected to the RJ-45 overall foil shield
Position 2 & 3	Not Connected	75 Ohm RX shield not connected to the RJ-45 overall foil shield

### Jumper JP4: 75 Ohm RX Shield to 120 Ohm Rx Pair Shield (Pin 6)

In the default “Connected” setting, the 75 Ohm coaxial shield connects to the RJ-45 overall foil shield.

JP4	Setting	Description
Position 1 & 2	Not Connected	75 Ohm RX shield not connected to the RJ-45 RX pair shield (Pin 6)
Position 2 & 3	Connected	75 Ohm RX shield connected to the RJ-45 RX pair shield (Pin 6)

### Jumper JP7: RJ-45 Shield to Chassis Ground

In the default “Connected” setting, the RJ-45 overall shield connects to chassis ground.

JP7	Setting	Description
Position 1 & 2	Connected	RJ-45 shield connects to Frame Ground.
Position 2 & 3	Not Connected	RJ-45 shield does not connect to Frame Ground.

This section describes the functions of the Model 460RC16 rack chassis, tells how to install front and rear Model 460RC/F Series cards into the chassis, and how to connect to the twisted pair interface and the serial interface.

### 4.1 THE MODEL 460R16 RACK CHASSIS

The Model 460R16 Rack Chassis (Figure 3, below) can accommodate up to 16 G.703 75 Ohm coax to 120 Ohm RJ-45 baluns. Measuring only 3.5” high, the Model 460R16 is designed to occupy only 2U in a 19” rack. Sturdy front handles allow the Model 460R16 to be extracted and transported conveniently.

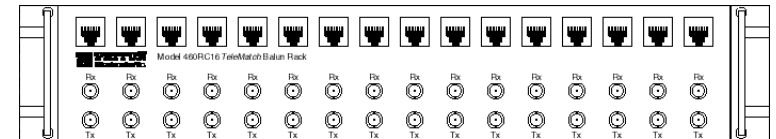

Figure 3. Fully Populated Model 460RC16 Rack Chassis

### 4.2 INSTALLING THE MODEL 460RC/F MODULE INTO THE CHASSIS

The Model 460RC16 comprised of a 2U high rack chassis and individually mountable G.703 balun modules. You may purchase a fully populated 16 port rack or you may purchase individual modules. Refer to Figure 4 as a guide and follow the steps below to install each Model 460RC/F module into the rack chassis:

1. Slide the two star washers over the screws on each end of the mount space.
2. Slide the Model 460RC/F pc board over the screws with the BNC connectors facing downward. Then push the BNC connectors and RJ-45 connector through the matching slots in the front of the rack assembly.
3. Slide a plastic spacer over each screw to secure the pc board.

4. Install the lexan shield over the spacers.

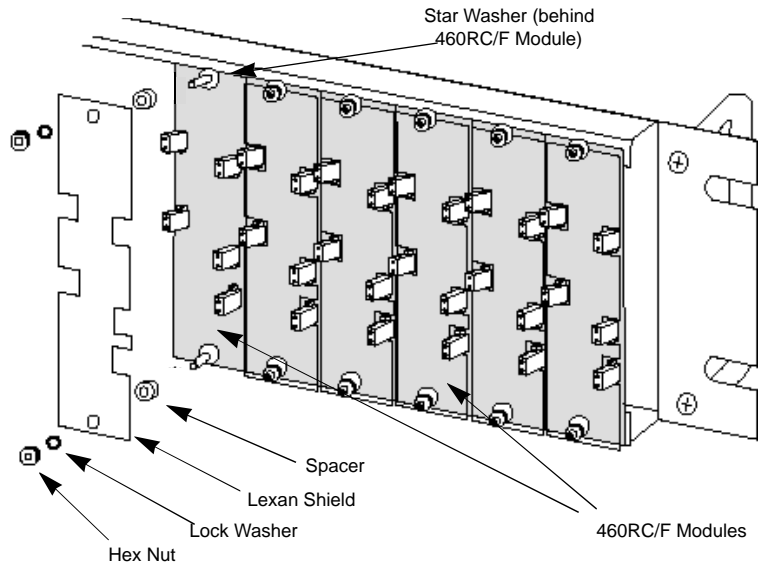

Figure 4. Mounting a Model 460RC/F Module to the Rack

5. Secure the 460RC/F card assembly by connecting a lock washer and hex nut on each screw.

### 4.3 CONNECTING THE 75 OHM BNC PORTS

The 75 Ohm BNC ports on the front of the 460R16 are labeled "TX" (Transmit Data Output) and "RX" (Receive Data Input). Simply connect the G.703 lines as follows\*:

<b>G.703 Network BNC Connector</b>	<b>Model 460RC/F BNC Connectors</b>
TX _____	RX _____
RX _____	TX _____

**\*NOTE:** The total allowable cable lengths are subject to the constraints of the ITU/CCITT G.703 recommendation. However, we recommend a total patch cable length, including coaxial and twisted pair cabling, of no more than 320 feet (200m).

### 4.4 CONNECTING THE 120 OHM RJ-45 PORTS

The pin configuration of the 120 Ohm twisted pair port is shown below:

<b>RJ-45 Pin(s)</b>	<b>Function</b>
1 .....	TX Output
2 .....	TX Output
3 .....	TX Shield
4 .....	RX Input
5 .....	RX Input
6 .....	RX shield
7 .....	no connection
8 .....	no connection

Simply install the twisted pair wires by making the following connections.

<b>G.703 Instrument</b>	<b>Model 460RC/F RJ-45 Pin No.</b>
TX Output _____	4
TX Output _____	5
TX Shield _____	3
RX Input _____	1
RX Input _____	2
RX Shield _____	6

**\*NOTE:** The total allowable cable lengths are subject to the constraints of the ITU/CCITT G.703 recommendation. However, we recommend a total patch cable length, including coaxial and twisted pair cabling, of no more than 320 feet (200m).

**APPENDIX A**

**PATTON ELECTRONICS MODEL 460RC  
SPECIFICATIONS**

<b>Transmission Line:</b>	CCITT G.703 (unstructured)
<b>Data Rate:</b>	2.048 Mbps
<b>75 Ohm Connection:</b>	Dual coax BNC connectors, male or female (RG 59 or 2002 coax)
<b>120 Ohm Connection:</b>	Shielded RJ-45 jack
<b>Power Supply:</b>	none required
<b>Link-to-Data Isolation:</b>	500 volts AC/DC
<b>Temperature Range:</b>	32-122°F (0-50°C)
<b>Dimensions (w/o handles):</b>	19" Wide x 3.5" High x 1.9" Deep (48.3 x 8.9 x 4.8 cm)

**APPENDIX B**

**PATTON ELECTRONICS MODEL 460RC  
FACTORY REPLACEMENT PARTS  
AND ACCESSORIES**

<u>Model #</u>	<u>Description</u>
460R16 .....	Empty Balun Rack Panel
460RC/F .....	G.703 Balun Rack Module
05R16S460RC.....	Lexan Shield
056345.....	Star Washer
0562-06.....	Spacer
0561LW.....	Lock Washer
055.....	Hex Nut
07M460RC.....	Model 460RC User Manual

APPENDIX C

PATTON ELECTRONICS MODEL 460RC/F  
PIN ASSIGNMENTS

120 OHM TWISTED PAIR INTERFACE

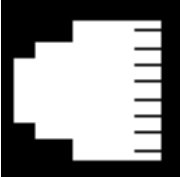
RJ-45 Jack	Pin No./Signal
	1 - Transmit Data Out
	2 - Transmit Data Out
	3 - Transmit Data Shield
	4 - Receive Data In
	5 - Receive Data In
	6 - Receive Data Shield
	7 - no connection
	8 - no connection

APPENDIX D

PATTON ELECTRONICS MODEL 460RC/F  
BLOCK DIAGRAM

