

MODEL:

PDUMV15NET

Switched Rackmount PDU



Low Voltage
Input/Output



16 Outlets



15A Max Capacity



Load Meter

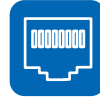

Network
Interface



0U Rackmount



Toolless
Mounting
Buttons

- A** Digital Load Meter
- B** 5-15/20R Outlets with On/Off LEDs
- C** Durable Metal Case
- D** Removable Cord Retention Brackets
- E** Removable Mounting Brackets
- F** Toolless Mounting Buttons
- G** 10 ft. Input Power Cord
- H** 5-15P Input Plug
- I** Network Interface
- J** RJ45 Ethernet Jack
- K** Manual Configuration Port
- L** Environmental Monitoring Port
- M** Network Interface Reset Button

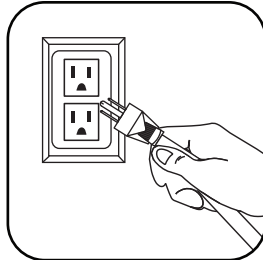

AC Input Connection: Insert 5-15P plug into compatible 5-15R or 5-15/20R utility, generator or UPS outlet.

Also Includes: Cable Ties, Owner's Manual

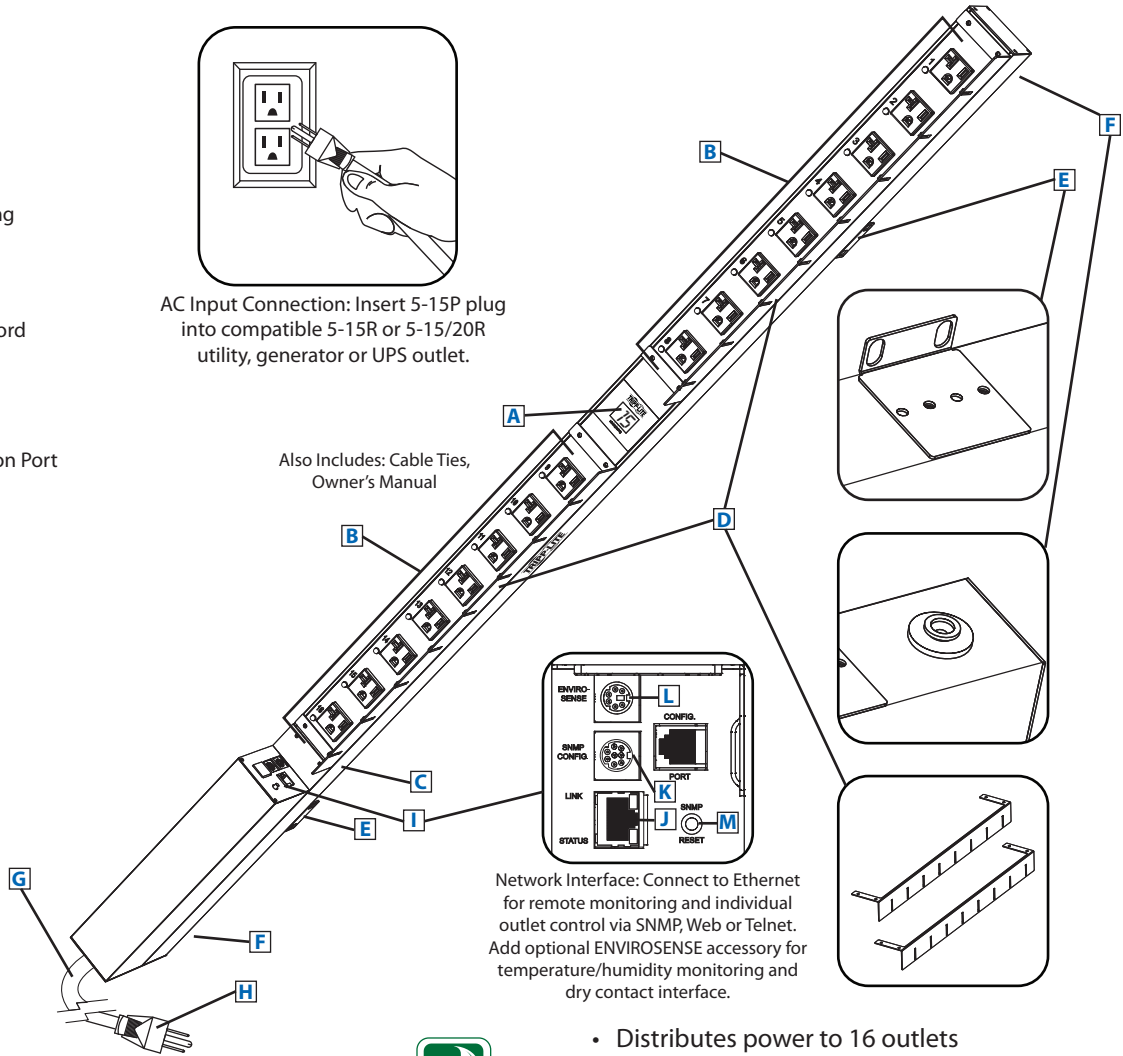

Network Interface: Connect to Ethernet for remote monitoring and individual outlet control via SNMP, Web or Telnet. Add optional ENVIROSENSE accessory for temperature/humidity monitoring and dry contact interface.

Specifications

Model	PDUMV15NET
Voltage	100-125V
Frequency	50/60 Hz
Maximum Capacity	15A
Agency-Derated Capacity	12A
Input Connector	5-15P
Cord Length	10 ft.
Outlets	16 (5-15/20R)
Primary Mounting Option	0U (Vertical) Rackmount
Unit Weight & Dimensions	7 lb / 4.25 x 49 x 2.25 in. <i>See next page for detailed unit measurements.</i>
Certifications	Tested to UL 60950-1 (US & Canada), NOM (Mexico), FCC Class A

Tripp Lite has a policy of continuous improvement. Specifications are subject to change without notice.



- Distributes power to 16 outlets
- Remote monitoring and control via SNMP, Web or Telnet
- Displays total load in real time
- Perfect for rackmount server, network and telecom applications

SEE NEXT PAGE FOR DETAILED UNIT MEASUREMENTS



1111 W. 35th Street
Chicago, IL 60609 USA
773.869.1234
www.tripplite.com

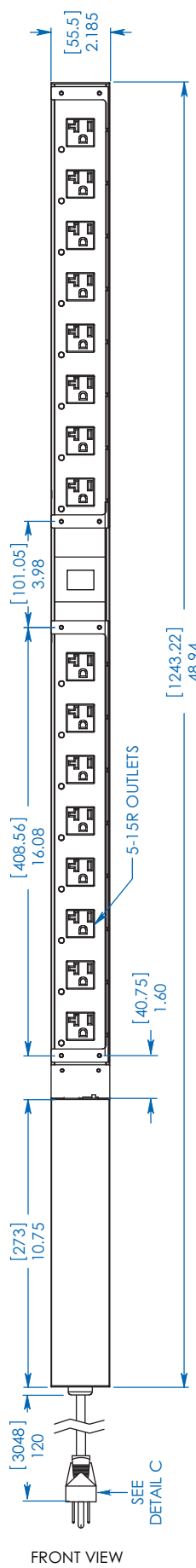

FRONT VIEW

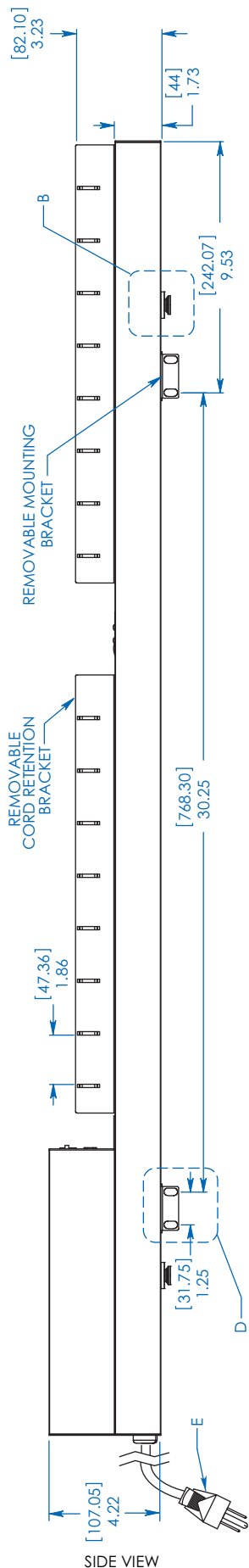

SIDE VIEW

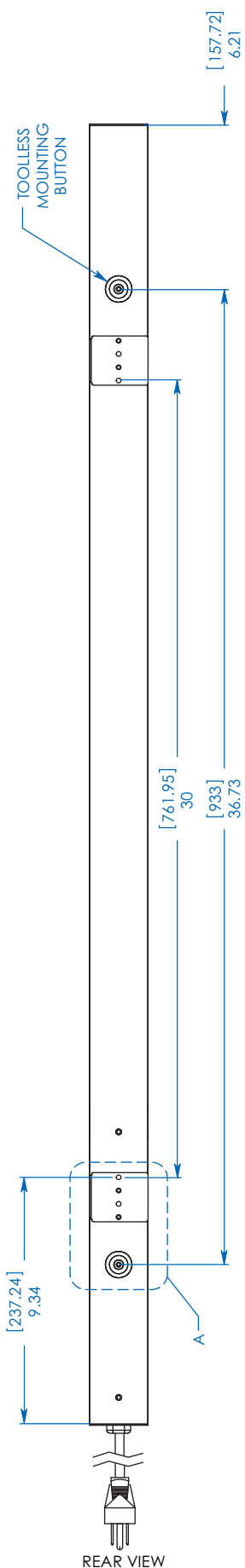

REAR VIEW

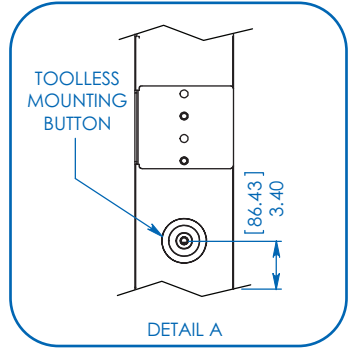

DETAIL A

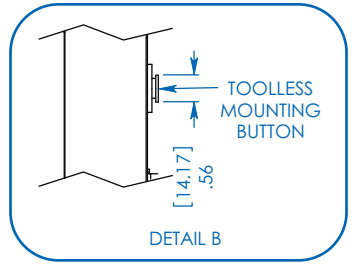

DETAIL B

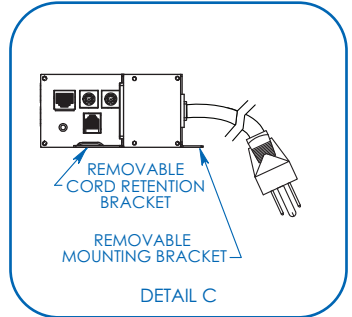

DETAIL C

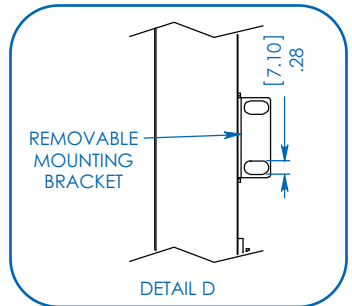

DETAIL D

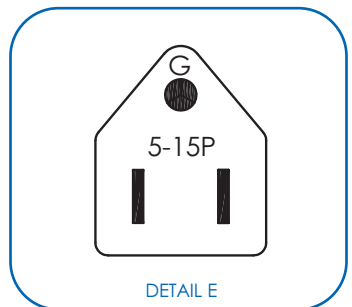

DETAIL E

MODEL:
PDUMV15NET



1111 W. 35th Street
Chicago, IL 60609 USA
773.869.1234
www.triplite.com

Dimensions: [mm] INCHES

Tripp Lite has a policy of continuous improvement. Specifications are subject to change without notice.