

# Power Spot 700 CMY II

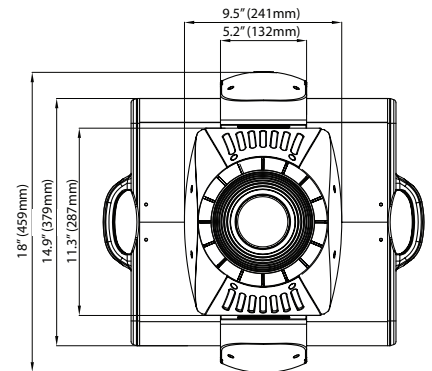
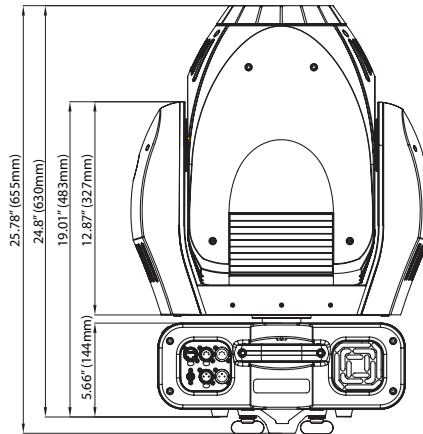

Power Spot 700 CMY II Dimensions

The Power Spot 700 CMY II by Elation Professional is a 700W CMY color mixing moving head hybrid (spot or wash in one) with use of the variable frost effect. Featuring CMY color system plus a fixed color wheel with 8 static colors as well as variable CTO, two gobo wheels with 9 fixed and 7 rotating gobos featuring the new Quick Snap™ rotating gobo and animation wheel system. The animation wheel can simulate effects such as running water, fire, clouds, etc. Additional effects include rotating 3-facet prism, Iris, mechanical dimmer / shutter system. This unit includes a motorized variable zoom beam angle from 14° to 32° and is equipped with unique modular internal construction allowing for easy access to key components. Control data input is via 3 pin or 5 pin DMX data connections first in and out cables. The unit's lamp fuse housing holds a 250v/10A GMA fuse (120v operation). The Power Spot 700 CMY II is equipped with the Philips MSR700 SA/2 Gold lamp and is IP20 rated, designed for indoor applications only and features a multi-voltage electronic ballast and power supply. Rigging for this unit includes 2 x 1/4 turn omega brackets. Additional gobos and animation wheels are supplied.

## FEATURES

- 700W short arch discharge lamp moving head hybrid
- Full Color mixing with Cyan Magenta Yellow flag system + 8 dichroic filters plus white
- 2 gobo wheels with 9 fixed and 7 rotating and interchangeable
- 1 variable speed replaceable rotating animation wheel
- 4 extra animation wheels included
- 8 optional animation wheels available
- Variable frost control hard edge to soft edge
- 3-facet rotating/Indexing Prism
- Sound active mode - built in mic. lamp on/off power con mains
- Motor driven focus from near to far
- Maximum PAN-movement 540° 16-bit resolution
- TILT-movement 280° 16-bit resolution
- 4 digit L.E.D. display
- On board menu settings
- DMX control via 24 channels
- Modular design allows easy access to key components

## TECHNICAL SPECIFICATIONS

- **DMX Channels:** 24 DMX Channels, RDMX - Remote DMX Addressing
- **Control:** USITT DMX-512 (16-bit resolution), 3-pin and 5-Pin XLR serial input/output
- **Dimmer:** Dual Flag mechanical dimming system
- **Strobe:** Variable speed strobe effect (1-10) flashes per second
- **IP Rating:** IP 20
- **Iris:** Beam narrow to wide (4% - 100%)
- **Zoom:** 14° - 32° linear zoom
- **Power Supply:** AC 90-260V 50/60Hz
- **Power Consumption:** 900W
- **Fuse:** Electronic ballast
- **Lamp:** Phillips MSR 700 SADE/2
- **Lamp life:** 700W, 72V, 7500°K, 1000 HRS
- **Dimensions:** (LxWxH) 19" x 14" x 29" / 482.6 x 355.6 x 736.6 mm
- **Weight:** 63 lbs. / 28.5 kg
- **Rigging:** 2 x 1/4 Turn omega brackets  
4 x M-10 threaded holes for clamps



# Power Spot 700 CMY II



## COLORS / GOBOS

### COLORS (16 Bit) + CMY COLOR MIXING

- Full Color mixing with Cyan Magenta Yellow flag system + 8 dichroic filters plus white
- Color wheel 1: 8 dichroic filters plus white, 9 half colors
- Continuous, variable speed, color scrolling in both directions (rainbow effect)
- 0-100% 3,200K CTC flag system for variable color correction



### GOBOS (16 Bit)

- Gobo-wheel 1: 9 fixed exchangeable standard gobos plus "open"
- Gobo-wheel 2: 7 exchangeable, rotating Quick-Snap™ gobos plus "open"
- Gobo outside diameter 26.9 mm, image size 23 mm
- Gobo thickness: glass = 1.1 - 3.0 mm, steel = 0.3 mm
- Gobo Overlay (Gobo Morphing)

Gobo Wheel 1 - Fixed

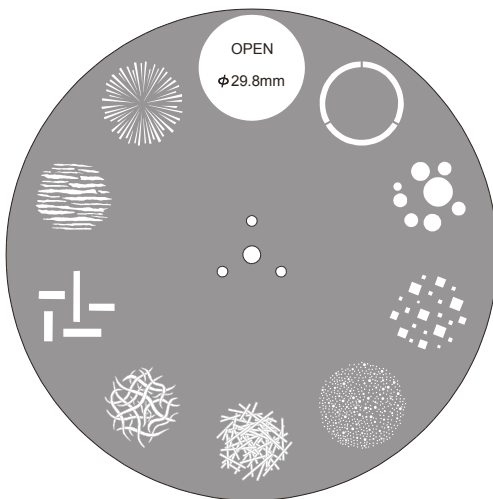

Gobo Wheel 2 - Rotating

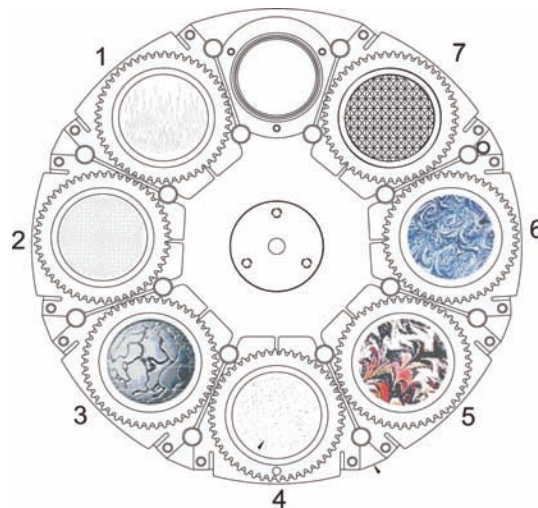

## ANIMATION WHEELS

- 1 variable speed replaceable rotating animation wheel
- 4 extra animation wheels included
- 8 optional animation wheels available

Standard (included)

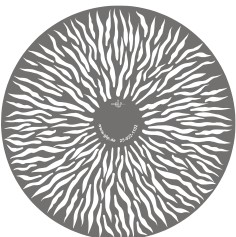

Optional (included)

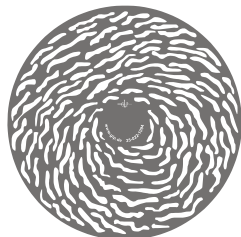

Optional (included)

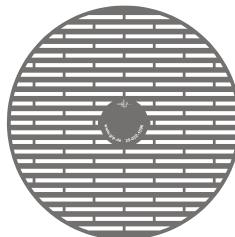

Optional (included)

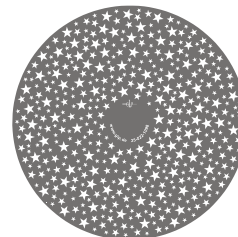

Optional (included)

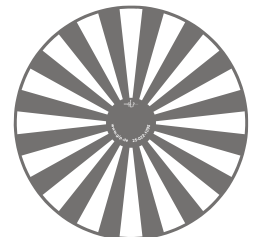

# Power Spot 700 CMY II



## PHOTOMETRICS

### Power Spot 700

#### Photometric Data

Illuminance (lux or fc):	122250 cd/distance $\leq$ (m or ft)
Beam diameter:	$\sim 0.62 \times$ distance
Field angle:	$\sim 34.6^\circ$
Color temperature:	7500 Kelvin (no color filters applied)
Measurement conditions:	230V ~ / 50Hz
Measurement source:	Osram HTI 700W/D4/75

All information is subject to change without prior notice

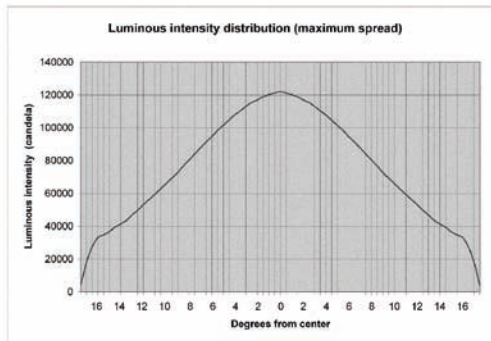
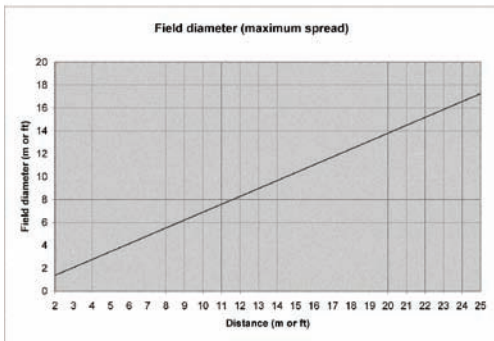
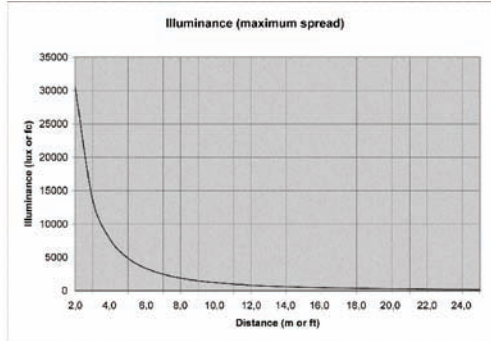

## DMX TRAITS

- Channel 1 - Pan
- Channel 2 - Pan fine
- Channel 3 - Tilt
- Channel 4 - Tilt fine
- Channel 5 - Color 1 (fast)
- Channel 6 - Cyan
- Channel 7 - Magenta
- Channel 8 - Yellow
- Channel 9 - Gobo 1 (indexed)
- Channel 10 - Gobo 1 (position/rotation)
- Channel 11 - Gobo 2 (fast)
- Channel 12 - Shutter
- Channel 13 - Dimmer
- Channel 14 - Focus
- Channel 15 - Zoom
- Channel 16 - Frost
- Channel 17 - Prism
- Channel 18 - Iris
- Channel 19 - CTO
- Channel 20 - Effect wheel swing
- Channel 21 - Effect wheel (position/rotation)
- Channel 22 - Special
- Channel 23 - Movement
- Channel 24 - Speed Pan/Tilt

DRC 700  
Road Case for  
2 x Power Spot 700  
(Sold separately)



### MODULAR DESIGN



Allows easy access to key components

Product Order Code	Description
POWER SPOT 700CMY II	700W moving head black
Accessories Order Code	Description
25-022-1094	Optional animation wheel (leaves)
25-022-1096	Optional animation wheel (bricks)
25-022-1098	Optional animation wheel (stars)
25-022-1095	Optional animation wheel (fans)
ZB-MSR700/SA/DE	Philips Gold 700W lamp double ended
23-001-1202	Hanging Bracket
PRO CLAMP	500Kg 2" wrap around aluming clamp
TRIGGER CLAMP	500Kg 2" aluminum J clamp
DRC 700	Dual road case
DRC 700PRO	Dual road case pro
SRC 700	Single Road case