

KIT FEATURES

- ▶ Shaft unit provisions

KIT COMPONENTS

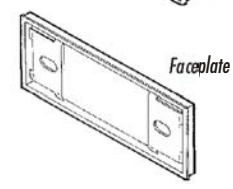
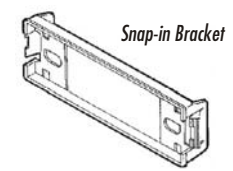

TOOLS REQUIRED



99-9123

INSTALLATION INSTRUCTIONS

APPLICATIONS

CAR	PAGE
VOLKSWAGEN	
Jetta 1994-00.....	1-2
Passat 1998-00.....	1-2



ALL VEHICLES

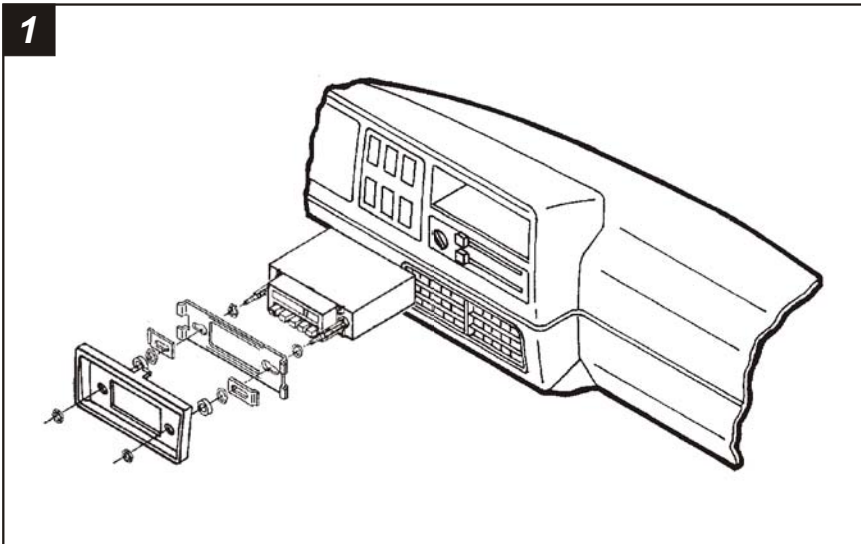

Disconnect the negative battery terminal to prevent an accidental short circuit. Remove the factory radio knobs and shaft nuts. Unclip the factory faceplate. Insert a flat-blade screwdriver into the shaft wells and push in on the side springs. Pull the factory radio out and disconnect the wiring.

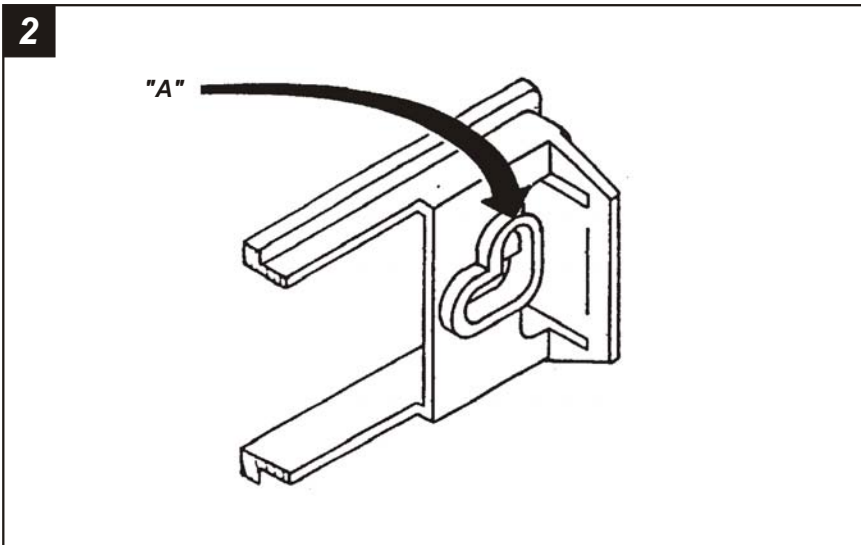

Slide the aftermarket head unit into the **Snap-in Bracket**. If the shafts of the head unit do not pass easily through the kit, cut and remove the upper-shaft tabs from the shaft openings. ("A")

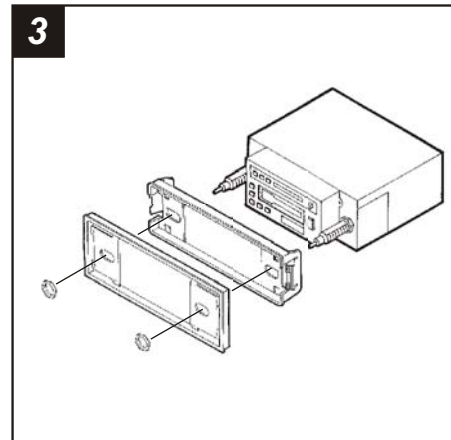

Attach the **Faceplate** to the **Snap-in Bracket**. Slide the aftermarket head unit into the kit and secure with shaft nuts.

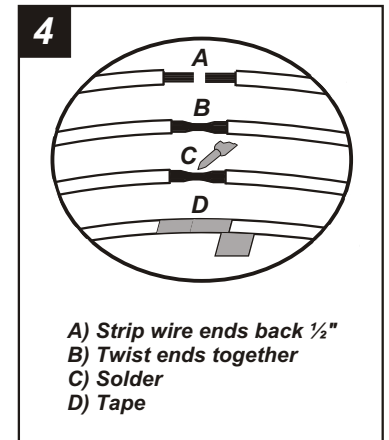

- A) Strip wire ends back $\frac{1}{2}$ "
- B) Twist ends together
- C) Solder
- D) Tape

Locate the factory wiring harness in the dash. Metra recommends using the proper mating adaptor and making connections as shown. (Isolate and individually tape off the ends of any unused wires to prevent electrical short circuit).

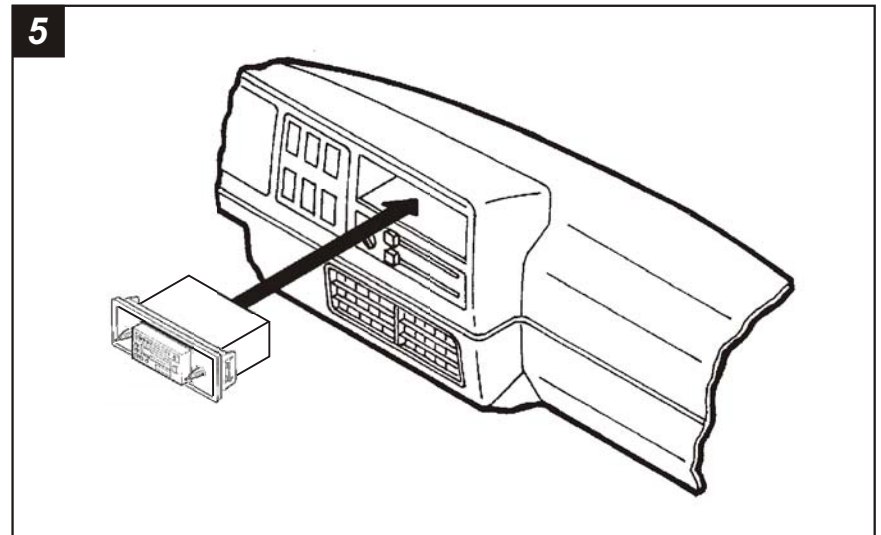

Re-connect the battery terminal and test the unit for proper operation. Snap the head unit/kit assembly into the sub-dash.