

SAVE THESE INSTRUCTIONS

NOTE: Check ALL parts for shipping damage. In case of shipping damage, DO NOT use. Contact Dealer/Carrier.

SPECIAL NOTES

WHEELCHAIR TIE-DOWN RESTRAINTS AND SEAT POSITIONING STRAPS

Invacare recommends that wheelchair users NOT be transported in vehicles of any kind while in wheelchairs. As of this date, the Department of Transportation has not approved any tie-down systems for transportation of a user while in a wheelchair, in a moving vehicle of any type.

It is Invacare's position that users of wheelchairs should be transferred into appropriate seating in vehicles for transportation and use be made of the restraints made available by the auto industry. Invacare cannot and does not recommend any wheelchair transportation systems.

AS REGARDS RESTRAINTS - SEAT POSITIONING STRAPS - IT IS THE OBLIGATION OF THE DME DEALER, THERAPISTS AND OTHER HEALTH CARE PROFESSIONALS TO DETERMINE IF A SEATING POSITIONING STRAP IS REQUIRED TO ENSURE THE SAFE OPERATION OF THIS EQUIPMENT BY THE USER. SERIOUS INJURY CAN OCCUR IN THE EVENT OF A FALL FROM A WHEELCHAIR.

SAFETY SUMMARY

The following recommendations are made for the safe installation and use of the ADULT LAP BELT:

GENERAL WARNINGS

DO NOT install this equipment without first reading and understanding this instruction sheet. If you are unable to understand these instructions, contact a healthcare professional, dealer or technical personnel if applicable before attempting to install this equipment - otherwise, injury or damage may occur.

Ensure that the seat is fixed to the wheelchair. A loose seat may lead to potentially dangerous situations with positioning devices.

SAFETY SUMMARY (CONTINUED)

GENERAL WARNINGS

It is strongly recommended that the lap belt be strapped across either the leg or hip area. This can be achieved by using an angle of 45° and 90°, this is referring to the angle the lap belt makes with the seating surface. **DO NOT** use angles less than 45° or parallel to the seating surface. This makes it easier for the user to slip under the belt.

ATTACHING THE LAP BELT (FIGURE 1)

NOTE: Refer to the GENERAL WARNINGS in the SAFETY SUMMARY of this instruction sheet.

1. The lap belt can be anchored in one (1) of the two (2) possible locations:
 - a. In one (1) of the T-nutted holes located on the underside of the seat.
 - b. In one (1) of the holes in the side frame of the wheelchair.

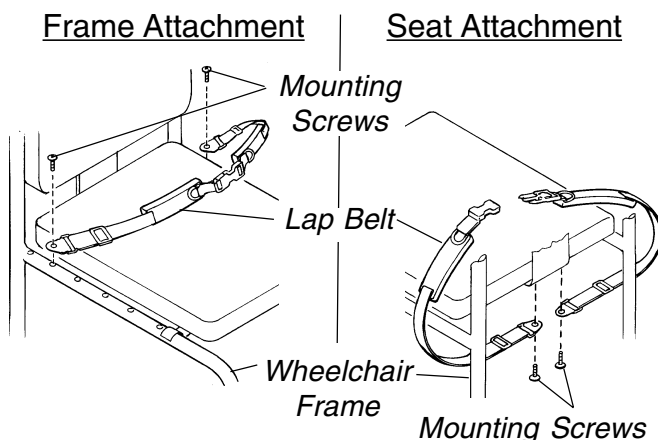

Lap Belt (Acceptable lap belt angles are between 45° and 90° with the seat surface)

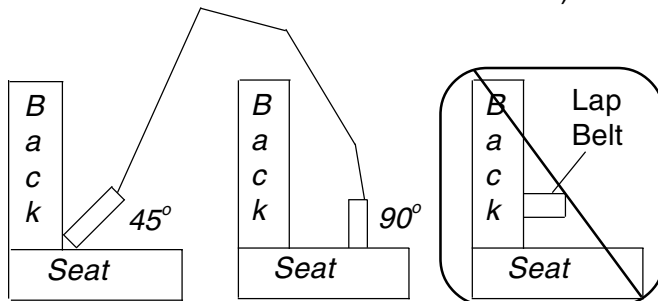

FIGURE 1 - ATTACHING THE LAP BELT

NOTE: The most desirable location for the mounting screws will be determined by the size of the client involved and the angle achieved by trying the various attachment points with the client seated comfortably in the wheelchair.

2. Determine the most suitable attachment point. Put the padded side of the belt toward the seating surface.
3. Align the hole located at the anchor end of the belt with the chosen attachment point and insert one (1) of the mounting screws provided. **HAND TIGHTEN ONLY.** Repeat for opposite side.

USING THE LAP BELT (FIGURE 2)

NOTE: Refer to the GENERAL WARNINGS in the SAFETY SUMMARY of this instruction sheet.

NOTE: Stabilize from the ground up. A stable base (seat) and footrest are the first steps to a stable pelvis. Also, the user should be lightly clothed for the initial adjustment.

NOTE: A belt angle of 45° - 60° will usually provide the best stability and positioning. The belt will apply its pressure directly to the hips, usually allowing more force to be applied without discomfort.

NOTE: A belt angle of 60° - 90° will often provide greater mobility than lesser angles, unless client functional mobility is highly dependent on stability.

1. Adjust the slide, located at each end of the belt, to fit the client with proper tension.
2. The plastic D-rings, located at the front of the belt, can be pulled or released to conveniently tighten the belt to provide extra tension if needed or loosen the belt to allow for bulky clothing, etc.

NOTE: When all final adjustments have been made and the client is comfortable with the fit of the lap belt, any excess lengths of material can be cut off, keeping in mind the potential future growth of the client. The cut end can be melted slightly to prevent fraying.

CHILD/JUNIOR LAP BELT

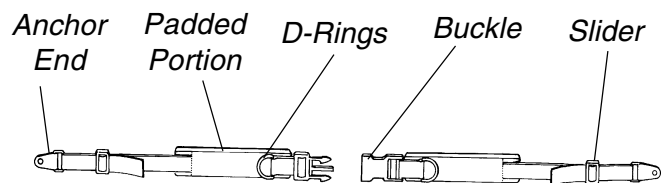

ADULT LAP BELT

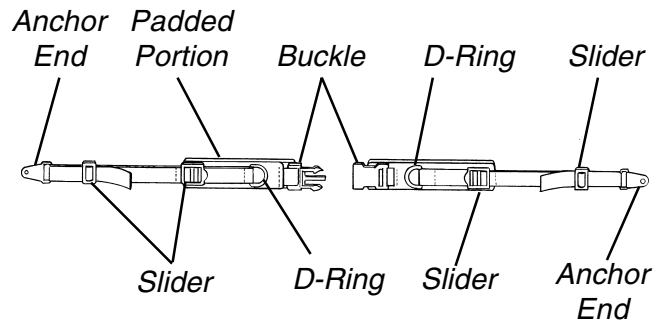

FIGURE 2 - USING THE LAP BELT

LIMITED WARRANTY

PLEASE NOTE: THE WARRANTY BELOW HAS BEEN DRAFTED TO COMPLY WITH FEDERAL LAW APPLICABLE TO PRODUCTS MANUFACTURED AFTER JULY 4, 1975.

This warranty is extended only to the original purchaser/user of our products.

This warranty gives you specific legal rights and you may also have other legal rights which vary from state to state.

Invacare warrants its product to be free from defects in materials and workmanship for the period of two (2) years of use by original purchaser. If within such warranty period any such product shall be proven to be defective, such product shall be repaired or replaced, at Invacare's option. This warranty does not include any labor or shipping charges incurred in replacement part installation or repair of any such product. Invacare's sole obligation and your exclusive remedy under this warranty shall be limited to such repair and/or replacement.

For warranty service, please contact the dealer from whom you purchased your Invacare product. In the event you do not receive satisfactory warranty service, please write directly to Invacare at the address on the next page. Provide dealer's name, address, model number, and the date of purchase, indicate nature of the defect and, if the product is serialized, indicate the serial number.

Invacare Corporation will issue a return authorization. The defective unit or parts must be returned for warranty inspection using the serial number, when applicable, as identification within thirty (30) days of return authorization date. DO NOT return products to our factory without our prior consent. C.O.D. shipments will be refused; please prepay shipping charges.

LIMITATIONS AND EXCLUSIONS: THE WARRANTY SHALL NOT APPLY TO PROBLEMS ARISING FROM NORMAL WEAR OR FAILURE TO ADHERE TO THE ENCLOSED INSTRUCTIONS. IN ADDITION, THE FOREGOING WARRANTY SHALL NOT APPLY TO SERIAL NUMBERED PRODUCTS IF THE SERIAL NUMBER HAS BEEN REMOVED OR DEFACED; PRODUCTS SUBJECTED TO NEGLIGENCE, ACCIDENT, IMPROPER OPERATION, MAINTENANCE OR STORAGE; OR PRODUCTS MODIFIED WITHOUT INVACARE'S EXPRESS WRITTEN CONSENT INCLUDING, BUT NOT LIMITED TO: MODIFICATION THROUGH THE USE OF UNAUTHORIZED PARTS OR ATTACHMENTS; PRODUCTS DAMAGED BY REASON OF REPAIRS MADE TO ANY COMPONENT WITHOUT THE SPECIFIC CONSENT OF INVACARE; PRODUCTS DAMAGED BY CIRCUMSTANCES BEYOND INVACARE'S CONTROL; PRODUCTS REPAIRED BY ANYONE OTHER THAN AN AUTHORIZED INVACARE DEALER, SUCH EVALUATION SHALL BE SOLELY DETERMINED BY INVACARE.

THE FOREGOING WARRANTY IS EXCLUSIVE AND IN LIEU OF ALL OTHER EXPRESS WARRANTIES, IF ANY, INCLUDING THE IMPLIED WARRANTIES OF MERCHANTABILITY AND FITNESS FOR A PARTICULAR PURPOSE.

IT SHALL NOT EXTEND BEYOND THE DURATION OF THE EXPRESSED WARRANTY PROVIDED HEREIN AND THE REMEDY FOR VIOLATIONS OF ANY IMPLIED WARRANTY SHALL BE LIMITED TO REPAIR OR REPLACEMENT OF THE DEFECTIVE PRODUCT PURSUANT TO THE TERMS CONTAINED HEREIN. INVACARE SHALL NOT BE LIABLE FOR ANY CONSEQUENTIAL OR INCIDENTAL DAMAGES WHATSOEVER.

THIS WARRANTY SHALL BE EXTENDED TO COMPLY WITH STATE/PROVINCIAL LAWS AND REQUIREMENTS.



Yes, you can.™

Invacare Corporation

www.invacare.com

USA
One Invacare Way
Elyria, Ohio USA
44036-2125
800-333-6900

Canada
5970 Chedworth Way
Mississauga, Ontario
L5R 3T9, Canada
905-890-8838

Invacare is a registered trademark of Invacare Corporation.
© 2000 Invacare Corporation

Form No. 96-325 Part No. 1068858 Rev A (1) 2/00