

---

# INSTRUCTION MANUAL

---

**BUILT-IN HOB  
CIR597X**

Thank you for choosing our product.

We advise you to read this manual carefully. It contains all necessary instructions for maintaining unaltered the appearance and functional qualities of the cooking hob.

# Contents

1.	INSTRUCTIONS FOR SAFE AND PROPER USE	4
2.	POSITIONING OF HOB	6
3.	GAS CONNECTION	11
4.	ELECTRICAL CONNECTION	12
5.	ADAPTATION TO DIFFERENT TYPES OF GAS	13
6.	FINAL OPERATIONS	16
7.	USING THE HOB	17
8.	LEANING AND MAINTENANCE	19

THESE INSTRUCTIONS ARE VALID ONLY FOR END USER COUNTRIES WHOSE IDENTIFICATION SYMBOLS APPEAR ON THE COVER OF THIS MANUAL.

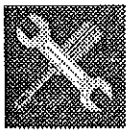

**INSTRUCTIONS FOR THE INSTALLER:** these are for the **qualified technician** who must carry out a suitable check of the gas system, install the appliance, set it functioning and carry out an inspection test.



**INSTRUCTIONS FOR THE USER:** these contain user advice, description of the commands and the correct procedures for cleaning and maintenance of the appliance.

# Introduction

## 1. INSTRUCTIONS FOR SAFE AND PROPER USE

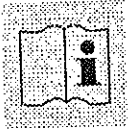

THIS MANUAL IS AN INTEGRAL PART OF THE APPLIANCE AND THEREFORE MUST BE KEPT IN ITS ENTIRETY AND IN AN ACCESSIBLE PLACE FOR THE WHOLE WORKING LIFE OF THE COOKING HOB. WE ADVISE READING THIS MANUAL AND ALL THE INSTRUCTIONS THEREIN BEFORE USING THE COOKING HOB. ALSO KEEP THE SERIES OF NOZZLES SUPPLIED. INSTALLATION MUST BE CARRIED OUT BY QUALIFIED PERSONNEL IN ACCORDANCE WITH THE REGULATIONS IN FORCE. THIS APPLIANCE IS INTENDED FOR DOMESTIC USES AND CONFORMS TO CURRENT **REGULATIONS IN FORCE**. THE APPLIANCE HAS BEEN BUILT TO CARRY OUT THE FOLLOWING FUNCTIONS: **COOKING AND HEATING-UP OF FOOD**. ALL OTHER USES ARE CONSIDERED IMPROPER. **THE MANUFACTURER DECLINES ALL RESPONSIBILITY FOR IMPROPER USE.**

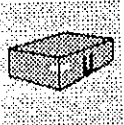

DO NOT LEAVE THE PACKING IN THE HOME ENVIRONMENT. SEPARATE THE VARIOUS WASTE MATERIALS AND TAKE THEM TO THE NEAREST SPECIAL GARBAGE COLLECTION CENTRE.

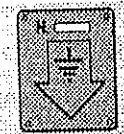

IT IS OBLIGATORY FOR THE ELECTRICAL SYSTEM TO BE GROUNDED ACCORDING TO THE METHODS REQUIRED BY SAFETY RULES.

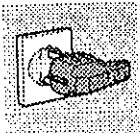

THE PLUG TO BE CONNECTED TO THE POWER CABLE AND THE SOCKET MUST BE THE SAME TYPE AND MUST CONFORM TO CURRENT REGULATIONS. THE SOCKET MUST BE ACCESSIBLE AFTER THE APPLIANCE HAS BEEN BUILT IN. **NEVER UNPLUG BY PULLING ON THE CABLE.**

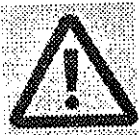

IMMEDIATELY AFTER INSTALLATION CARRY OUT A BRIEF INSPECTION TEST OF THE COOKING HOB, FOLLOWING THE INSTRUCTIONS BELOW. SHOULD THE APPLIANCE NOT FUNCTION, DISCONNECT IT FROM THE SUPPLY AND CALL THE NEAREST TECHNICAL ASSISTANCE CENTRE. **NEVER ATTEMPT TO REPAIR THE APPLIANCE.**

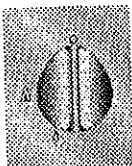

ALWAYS CHECK THAT THE CONTROL KNOBS ARE IN THE POSITION "ZERO" (OFF) WHEN YOU FINISH USING THE HOB.

# Introduction



THE IDENTIFICATION PLATE, WITH TECHNICAL DATA, SERIAL NUMBER AND MARKING IS CLEARLY VISIBLE UNDER THE CASING.

**THE PLATE ON THE CASING MUST NOT BE REMOVED.**

BEFORE CONNECTING THE DEVICE, MAKE SURE THAT IT HAS BEEN REGULATED FOR THE TYPE OF GAS THAT WILL FEED IT, CHECKING THE LABEL UNDER THE CASING.

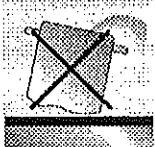

**DO NOT PUT PANS WITHOUT PERFECTLY SMOOTH AND FLAT BOTTOMS ON THE COOKING HOB GRIDS.**

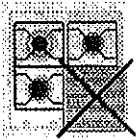

**DO NOT USE RECIPIENTS OR GRIDDLE PLATES THAT EXTEND BEYOND THE EXTERNAL PERIMETER OF THE HOB.**

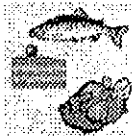

THIS APPLIANCE IS DESIGNED FOR COOKING FOOD AND IT SHALL NOT BE USED AS A SPACE HEATER.

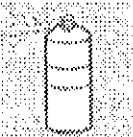

**DO NOT SPRAY AEROSOLS IN THE VICINITY OF THIS APPLIANCE WHILE IT IS IN OPERATION.**



**THE HOB IS TO BE USED BY ADULTS ONLY. DO NOT LET UNSUPERVISED CHILDREN PLAY WITH THE HOB.**

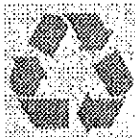

REPLACED APPLIANCES MUST BE TAKEN TO A SPECIAL GARBAGE COLLECTION CENTRE.



**The manufacturer declines all responsibility** for damage to persons or things caused by non-observance of the above prescriptions or by interference with any part of the appliance or by the use of non-original spares.

# Instructions for the installer

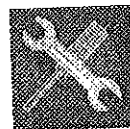

## 2. POSITIONING OF HOB



The following operation requires building and/or carpentry work so must be carried out by a competent tradesman. Installation can be carried out on various materials such as masonry, metal, solid wood or plastic laminated wood as long as they are heat resistant ( $T 90^{\circ}\text{C}$ ). Never use silicone or other insulating products when installing the appliance; use only the rubber gasket provided.

### 2.1.1 Attachment to support structure

Create an opening with the dimensions shown in the figure in the top surface of the counter, keeping a minimum distance of **50 mm** from the rear border.

This appliance can therefore be mounted against walls higher than the work surface on condition that a certain distance "X" be kept between the appliance and the wall as shown in the figure so as to avoid damage from overheating.

Make sure there is a minimum of **750 mm** between the hot plate flames and any shelf that may be installed directly above them.

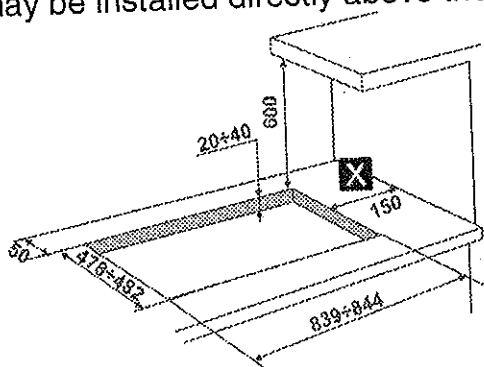

Accurately position the gasket provided all around the outer edge of the hole in the top surface as shown in the figures below, pressing it down so as to make it adhere properly. For measurements, refer to the figure depending on the hob model to be installed, bearing in mind that in both models the front and rear sides must skim the hole. Secure the hob to the counter with brackets **A** (supplied). Carefully trim any excess from border **B** of the gasket. The distances in the following drawing refer to the hole on the inner side of the gasket.

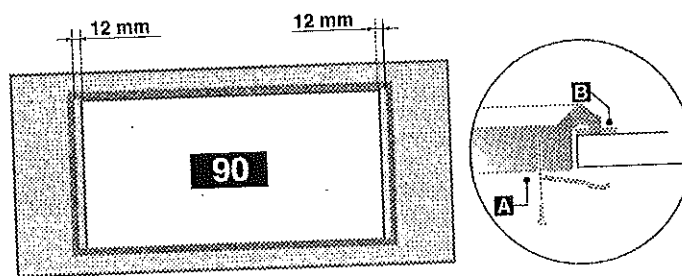

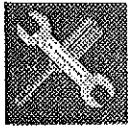

## Instructions for the installer

Overall dimensions: location of gas and electrical connection points (all measures in mm).

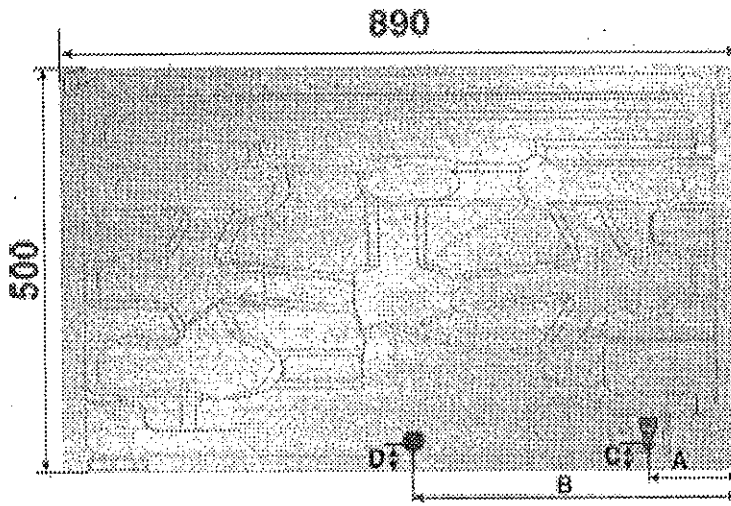

A	100
B	350
C	60
D	60

# Instructions for the installer



## 2.2 Clearance above and around domestic appliances

Extract from AS5601

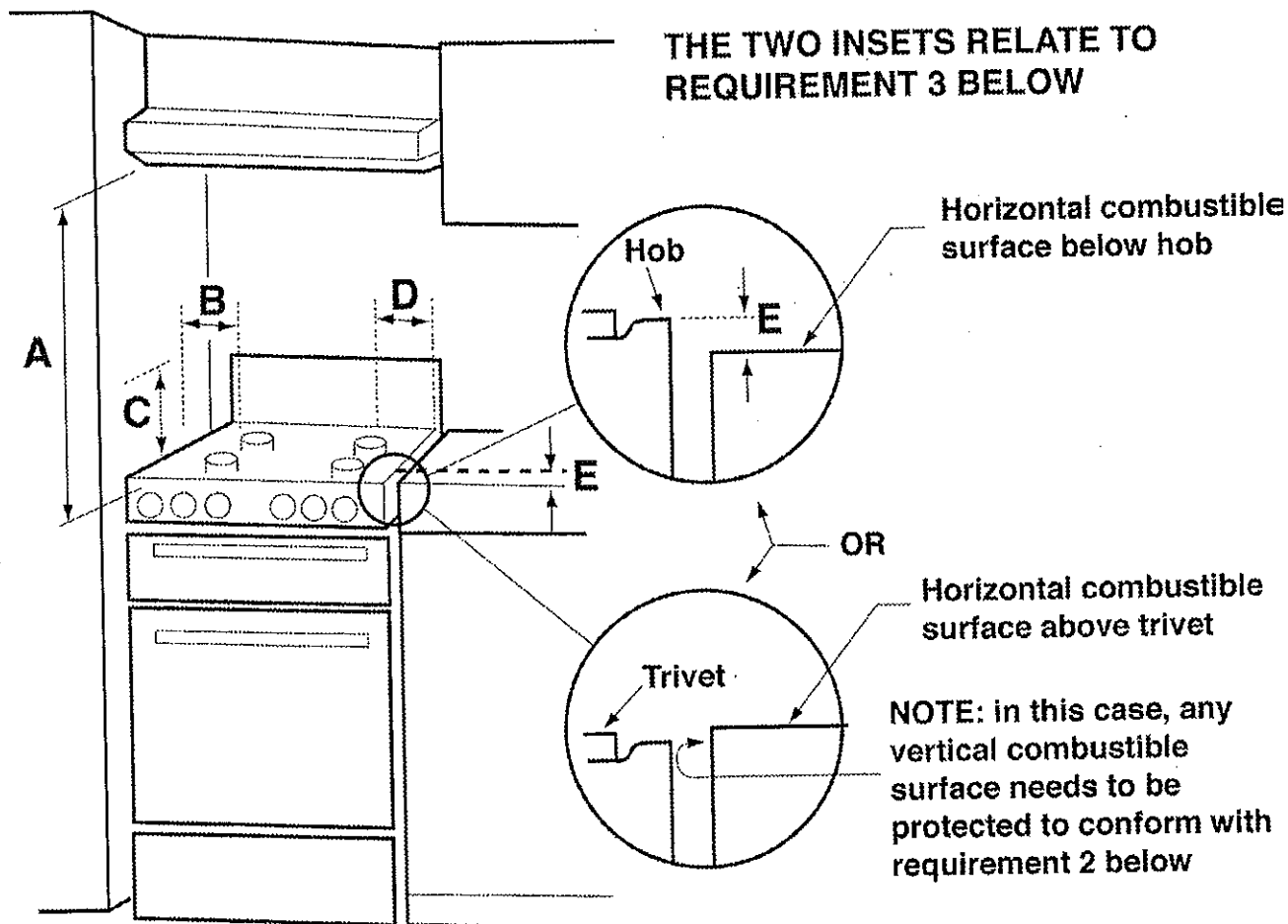

### REQUIREMENTS

- 1 Overhead clearances – (Measurement A)  
*Range hoods* and exhaust fans shall be installed in accordance with the manufacturer's instructions. However, in no case shall the clearance between the highest part of the *hob* of the cooking appliance and a *range hood* be less than **600 mm** or, for an overhead exhaust fan, **750 mm**.

Any other downward facing *combustible surface* less than **600 mm** above the highest part of the *hob* shall be protected for the full width and depth of the cooking surface area in accordance with Clause 5.12.1.2. However, in no case shall this clearance to any surface be less than **450 mm**.





## Instructions for the installer

- 2 Side clearances – (Measurements B & C)  
Where **B**, measured from the periphery of the nearest *burner* to any vertical *combustible surface*, is less than **200 mm**, the surface shall be protected in accordance with Clause 5.12.1.2 to a height **C** of not less than **150 mm** above the *hob* for the full dimension (width or depth) of the cooking surface area. Where the cooking *appliance* is fitted with a 'splashback', protection of the rear wall is not required.
  
- 3 Additional requirements for Freestanding and Elevated Cooking Appliances – (Measurements D & E)  
Where **D**, the distance from the periphery of the nearest *burner* to a horizontal *combustible surface* is less than **200 mm**, then **E** shall be **10 mm** or more, or the horizontal surface shall be above the *trivet*. See insets above.

### NOTES

- 1 Requirement 3 does not apply to a freestanding or elevated cooking appliance which is designed to prevent flames or the cooking vessels from extending beyond the periphery of the appliance.
- 2 The 'cooking surface area' is defined as that part of the appliance where cooking normally takes place and does not include those parts of the appliance containing control knobs.
- 3 For definition of hob, see Clause 1.4.64.
- 4 For definition of trivet, see Clause 1.4.109.
- 5 Consideration is to be given to window treatments when located near cooking appliances. See Clause 5.3.4.



## 2.3 Room ventilation

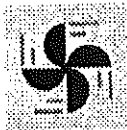

**Caution** – This hob may only be installed and operated in rooms permanently ventilated in accordance with current regulations. For proper operation of a gas appliance it is essential for the air necessary for combustion of the gas to be able to flow naturally into the room. Air must flow directly into the room through openings in its outside walls. This (these) opening (s) must have a free passage cross-section of at least 100 cm<sup>2</sup>, or 200 cm<sup>2</sup> for appliances not equipped with gas safety device. These openings must be constructed so that they cannot be obstructed indoors or outdoors, and should preferably be close to the floor on the side opposite to the combustion gas discharge point. If it is not possible to make the openings in the room where the cooker is installed, the necessary air may be taken from an adjoining room, provided it is not a bedroom or a room with fire risk.

## 2.4 Discharge of combustion products

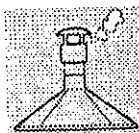

Discharge of combustion products must be guaranteed by means of hoods connected to a natural draught flue with certain efficiency, or by means of forced aspiration.

An efficient aspiration system requires careful planning by a specialist capable of installing it, respecting the positions and distances prescribed by standards. After installation, the installer must issue a certificate of conformity.



## Instructions for the installer

### 3. GAS CONNECTION

This appliance is suitable for installation with Natural Gas or ULPG (propane). Refer to page 12 for the relevant burner pressure and appropriate injector sizes. When the appliance is to be connected to Natural Gas then the pressure regulator supplied must be fitted to the gas inlet. A test point (for checking the gas pressure) is supplied either with the regulator or as a separate fitting in the case of LPG (propane) appliances.

Connection of the appliance to the gas supply must be in accordance with the requirements of AS5601. A ½" BSP connector at the inlet is recommended and the gas supply line to the appliance must be of adequate length to allow sufficient withdrawal of appliance for service or disconnection and be:

1. annealed copper pipe or;
2. flexible hose according to AS/NZ1869 & be at least Class "B", 10 mm diameter.

The appliance must be installed with provision to allow the gas to be turned off and disconnected for servicing and removal of the appliance as required from the gas supply.

Before the appliance is operated make certain all relevant parts are placed in the correct position.

When the installation is completed the installation connections of appliance will require to be leak tested, the burner operating pressure and flame checked and adjusted.

Warranty service calls do not cover these adjustments!

To check the operating pressure of the appliance it is recommended at least 2 large size burners are used. Ensure appliance is secured to wall when installation is completed.

N.G. The regulator supplied must be fitted to the ½ BSP thread at the rear of the appliance. An approved manual shut-off valve must be installed. The N.G. regulator must be checked and adjusted to 1.0kPa after installation.

**U.L.P.G.** Can be connected to the inlet fitting directly. The pressure must be checked to ensure it is operating at 2.75kPa. A separate test point fitting must be installed between the piping & the appliance for the pressure to be checked to ensure it is operating at 2.75kPa.

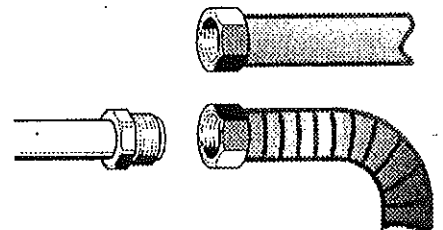
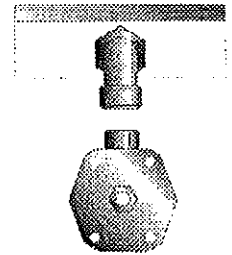

# Instructions for the installer



## 4. ELECTRICAL CONNECTION



Make sure that the voltage and capacity of the power line conform to the data shown on the plate located under the casing. **Do not remove this plate for any reason.**

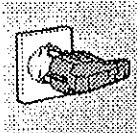

The plug on the end of the supply cable and the wall socket must be the same type and conform to the current electrical system regulations. Check that the power line is adequately grounded.

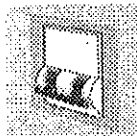

On the power line, install an omnipolar cut-off device with contact cut-off distance greater than or equal to **3 mm**, located in an easily accessible position near the unit.

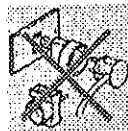

Do not use reducers, adapters or shunts.

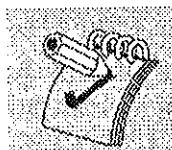

If the power cable is replaced, the wire section on the new cable must not be less than  $1.5 \text{ mm}^2$  (3 x 1.5 cable), keeping in mind that the end to be connected to the hob must have the ground wire (yellow-green) longer by at least 20 mm. Use only H05V2V2-F cable or similar which has a maximum temperature of  $90^\circ\text{C}$ . Any replacement needed should be carried out by a specialised technician who should make the mains connections according to the following diagram.

**L** = brown

**N** = blue

 = yellow-green

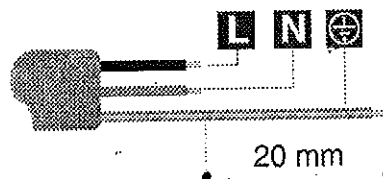

**The manufacturer will not be liable** for any damage to persons or property caused by non-observance of the above instructions or deriving from the tampering of even a single part of the hob.



## Instructions for the installer

### 5. ADAPTATION TO DIFFERENT TYPES OF GAS

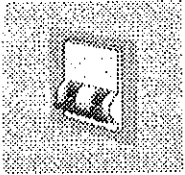

*Before performing any cleaning or maintenance work, detach the appliance from the electrical socket.*

The hob has been adjusted for natural gas at a pressure of 1.0kPa. For functioning with other types of gas the nozzles must be replaced and the primary air adjusted. To replace the nozzles and regulate the burners, you have to remove the top as described in the following paragraph.

#### 5.1 Removing the hob

1. Remove all the knobs, the grids, the burner caps and the flame-caps;
2. remove the screws and the nuts **A** that secure the burner supports;
3. remove plates **B**;
4. lift the hob from its seat;
5. replace the burner nozzles in accordance with the reference gas chart;
6. regulate the primary air as described in paragraph "5.2 Regulation for LPG".

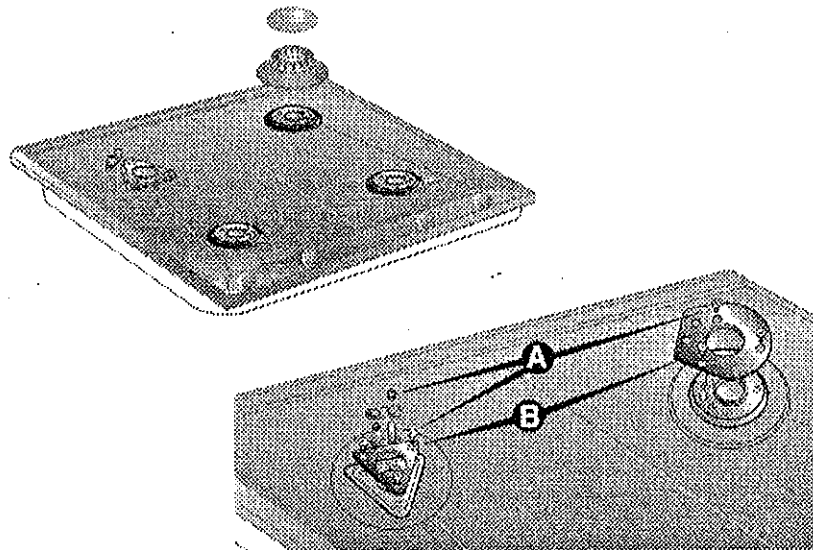

# Instructions for the installer



## 5.2 Regulation for LPG

Loosen screw A and push support B all the way. Use a double head wrench to remove nozzle C and assemble the suitable one, following the instructions indicated in the reference charts, with respect to the type of gas to use. The screwing torque of the nozzle should never exceed 3 Nm. Reposition support B so that nozzle C is covered perfectly. Place the burner on its support and ignite it. Move the Venturi tube D to regulate the air flow until the flame is stable and burns regularly, then secure the tube by means of screw A.

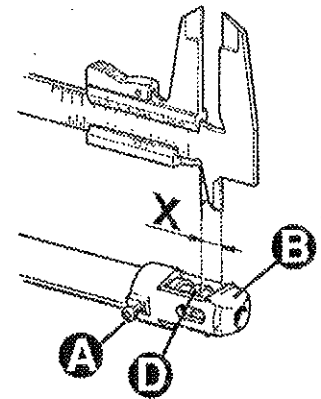
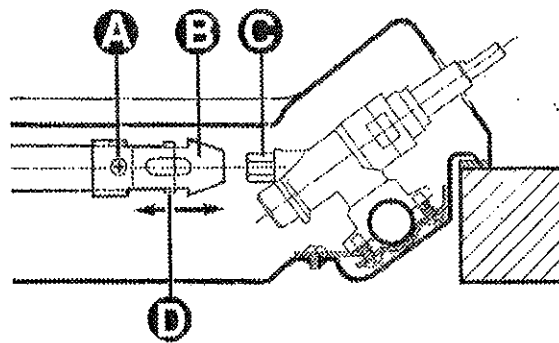

Burner	ULPG – 2.75 kPa	
	Nominal gas consumption (MJ/h)	Injector (mm)
Auxiliary (1)	4.8	0.60
Semi-rapid (2)	6.0	0.68
Rapid (3)	12.5	0.95
Double crown	internal (4)	3.8
	external (4)	14.4



## Instructions for the installer

### 5.3 Regulation for natural gas

The hob has been adjusted for natural gas at a pressure of 1.0kPa. To allow the unit to work back with this type of gas, after it has been adjusted for LPG, perform the same operations described in paragraph "5.2 Adjustment for LPG", but refer to the following table for the proper injectors.

Burner	NG – 1.0 kPa	
	Nominal gas consumption (MJ/h)	Injector (mm)
Auxiliary (1)	4.8	0.98
Semi-rapid (2)	6.0	1.10
Rapid (3)	12.2	1.55
Double crown	internal (4)	0.98
	external (4)	1.65

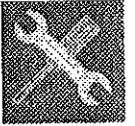

## 6. FINAL OPERATIONS

Having carried out the above adjustments, reassemble the appliance following, backwards, the instructions in paragraph "5.1 Removing the hob".

### 6.1 Regulation of minimum for natural gas

Replace the components on the burner and slide the knobs on the gas tap pins.

Light the burner and set it at minimum position.

Remove the knob and turn the regulation screw inside or next to the gas tap pin (depending on the model) until you get a suitable minimum flame.

Replace the knob and check burner flame stability: (rapidly turning the knob from maximum to minimum position, the flame should not go out).

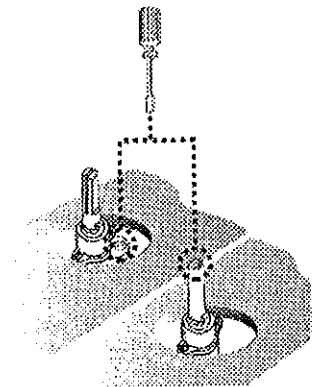

### 6.2 Arrangement of burners on hob

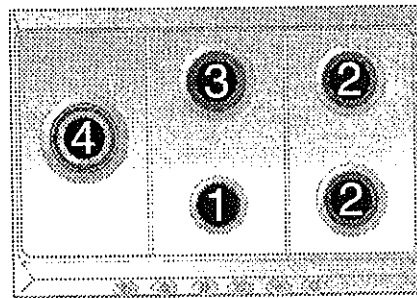
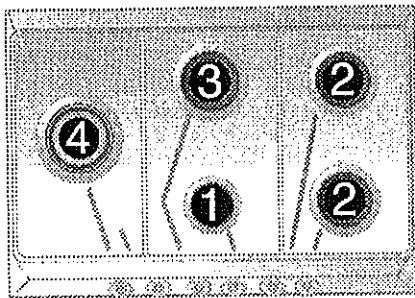

#### BURNERS

- 1 Auxiliary
- 2 Semi-rapid
- 3 Rapid
- 4 Double crown

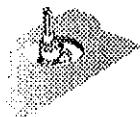

### 6.3 Lubrication of gas taps

After a while, the gas tap may become hard to turn or lock. If this happens, it has to be cleaned inside and re-greased.

**This must be done by a qualified technician.**





## Instructions for the user

### 7. USING THE HOB



Before turning on the burners, make sure that the burner rings, caps and grids have been fitted correctly. In the ultrarapid burner, notch **A** must be aligned with pin **B**. Grid **C** provided is intended for use with woks (Chinese pans).

Adapter **D** comes only with open grids models and is intended for use with small sized vessels.

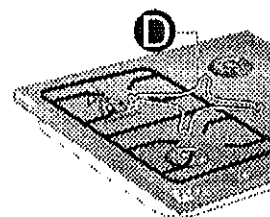
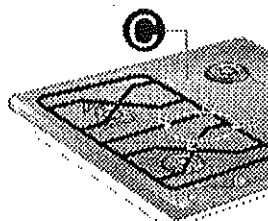
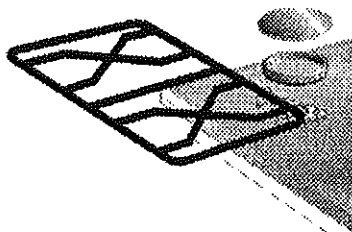
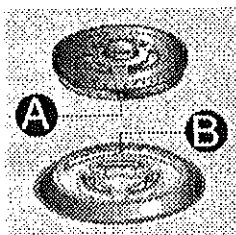

#### 7.1 Ignition of the burners

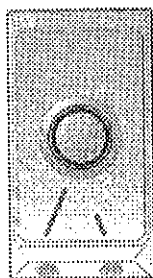

Raised indicators make for easier and clearer reading and use of the controls, each knob being connected to its corresponding burner by a rib. Setting corresponds to the elongated part of the knob or to the marking on it.

(Only where applicable)

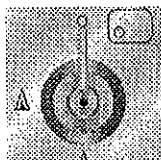

Double-crown burners, controlled by two knobs, feature two ribs, a long one corresponding to the small inner burner and a short one to the outer burner.

Double-crown burners comprise an auxiliary and a rapid burner, controlled by two different knobs which permit to use both burners at the same time or to select one or the other as required.

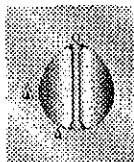

The device is fit with electronic ignition. Simply press and simultaneously turn the knob counter-clockwise on the low point flame symbol, until the burner is ignited. Concerning models with valves, push the knob for approximately 2 seconds in order to keep the flame burning and to activate the safety device. The burner might go off when the knob is released. In this case repeat the aforesaid operation keeping the knob pressed for more than 2 seconds.

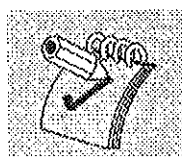

Should the burners go off accidentally in the models with valves, a safety device will trip after approximately 20 seconds to block the gas outlet even if the tap is open.

# Instructions for the user

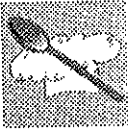

## 7.2 Practical advice for using the burners

For better burner performance and minimum gas consumption, flat bottomed, even recipients must be used, with covers and proportional in size to the burners (see paragraph "7.3 Diameter of containers").

To avoid overcooking or damage to the surface top while cooking, all recipients or griddles must be positioned within the cooking hob perimeter and must be a minimum distance of **3-4 cm** from the knobs.

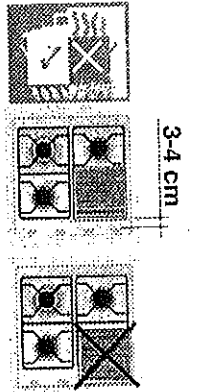

## 7.3 Diameter of containers

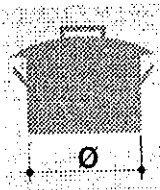

(*)	Burner	Ø min. and max. (in cm)
1	Auxiliary	12-14
2	Semi-rapid	16-24
3	Rapid	22-26
4	Double crown	12-30

(\*) For burner reference numbers, see page 16.

## 7.4 Using a griddle plate

A few precautions are necessary if you wish to use a griddle plate:

- leave a gap of at least 160 mm between the edge of the griddle plate and the side wall;
- if one of the burners close to the wooden rear wall is of triple flame type, leave a gap of at least 160 mm between this wall and the edge of the griddle plate;
- do not allow the burner flames to extend beyond the edge of the griddle plate;
- operate the burners underneath the griddle plate for 10 minutes at maximum power, then turn them down to the minimum setting. Never use the griddle plate for more than 45 minutes.



## Instructions for the user

### 8. LEANING AND MAINTENANCE

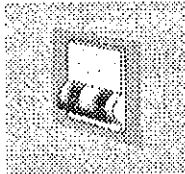

*Before any intervention, disconnect the power supply of the device.*

#### 8.1 Cleaning



*Clean the cooking top regularly every time you use it, obviously after it has cooled.*

##### 8.1.1 Regular daily cleaning of the hob

In order to clean and preserve the surface, always use specific products **only**, which do not contain abrasive substances or chlorine-based acid substances.

**How to use:** pour the product on a damp cloth and wipe the surface, rinse thoroughly and dry with a soft cloth or deerskin.

##### 8.1.2 Food stains or residues

Do not use metallic sponges or sharp scrapers: they will damage the surface.

Use normal non-abrasive products and remove spots or residuals with non-scratch sponges or, if need be, with wood or plastic utensils.

Rinse thoroughly and dry with a soft cloth or deerskin.

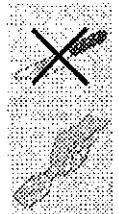

#### 8.2 Cleaning of cooking hob components

Grids, caps, flame cap crowns and burners can be removed for ease of cleaning. Wash them in warm water using a non-abrasive detergent, taking care to remove all tough spots. Before remounting, allow the components **to fully dry out.**

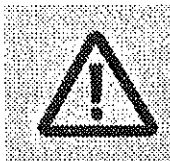
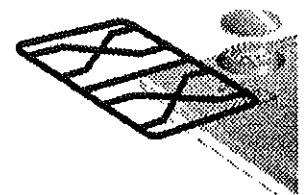

**CAUTION:** *do not wash these components in a dishwasher.*

## Instructions for the user

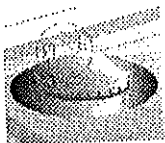
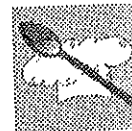

### 8.2.1 Ignition plugs and safety devices

For good functioning of the lighting ignition plugs and the safety devices, keep them very clean.

Check frequently and clean with a damp cloth when necessary.

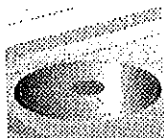

### 8.2.2 The electric element

After use, to make sure that the surfaces are clean and long lasting, the electric element must be treated with specific cleaning products which are available on the market. This necessary operation prevents oxidisation (rust formation).

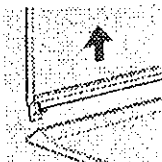

### 8.2.3 The cover

Clean the glass or steel cover, where mounted, with warm water. Never use abrasive sponges or detergents. To clean the rear part of the cooktop, remove the cover by lifting out.

When finished cleaning, refit the cover making sure to insert it correctly. Before lifting up the cover, dry out properly.

**Never lower the cover when burners or electric elements are on or still hot.**