

Contents

1. INSTRUCTIONS FOR PROPER USE	4
2. DISPOSAL INSTRUCTIONS – OUR ENVIRONMENT POLICY	4
3. SAFETY PRECAUTION	5
4. INTENDED USE OF THE APPLIANCE	6
5. KNOW YOUR COOKER	6
6. BEFORE FIRST USE	6
7. USE OF THE HOB	7
7.1 Lighting of the hob burners	7
7.2 Practical advice for using the hob burners	7
7.3 Diameter of the vessels to be used on each burner	7
8. FRONT CONTROL PANEL	8
9. USE OF THE OVENS	10
9.1 Warnings and general advice	10
9.2 Cooling system	10
9.3 Use of the electric grill in the large oven	10
9.4 Use of the electric grill in the auxiliary oven	10
9.5 How to use the grill	10
9.6 WARNING	11
9.7 Storage compartment	11
10. ELECTRONIC PROGRAMMER	12
10.1 Clock adjustment	12
10.2 Semiautomatic cooking	12
10.3 Automatic cooking	12
10.4 End of cooking	12
10.5 Minute Counter	13
10.6 Adjusting alarm volume	13
10.7 Switching off the alarm	13
10.8 Cancellation of set data	13
10.9 Changing the set data	13
11. CLEANING AND MAINTENANCE	14
11.1 Cleaning stainless steel	14
11.2 Ordinary daily cleaning	14
11.3 Food stains or residues	14
11.4 Cleaning of the hob components	14
11.5 Cleaning of oven	15
11.6 Door glass	15
12. EXTRAORDINARY MAINTENANCE	16
12.1 Lubrication of the taps	16
12.2 Replacement of light bulb	16
12.3 Removing the door	16
12.4 Oven door seal	16
13. INSTALLATION OF THE APPLIANCE	17
13.1 Electrical connection	17
13.2 Gas connection	18
13.3 Room ventilation	19
13.4 Clearance above and around domestic cookers	19
14. ADAPTATION TO DIFFERENT TYPES OF GAS	21
14.1 Replacement of nozzles on the hob	21
14.2 Burner and nozzle characteristics table	22
14.3 Arrangement of the burners on the hob	22
15. FINAL OPERATIONS	23
15.1 Regulation of the hob burner minimum level for natural gas	23
15.2 Regulation of the hob burner minimum level for ULPG	23
15.3 Mounting the rear top skirtboard (where applicable)	23
15.4 Wall fixing	24



INSTRUCTIONS FOR THE USER: these provide recommendations for use, a description of the controls and the correct procedures for cleaning and maintaining the appliance



INSTRUCTIONS FOR THE INSTALLER: these are intended for the **qualified engineer** who is to install, commission and test the appliance

Instructions for proper use

1. INSTRUCTIONS FOR PROPER USE



THIS MANUAL IS AN INTEGRAL PART OF THE APPLIANCE AND THEREFORE MUST BE KEPT IN ITS ENTIRETY AND IN AN ACCESSIBLE PLACE FOR THE WHOLE WORKING LIFE OF THE COOKER. WE ADVISE READING THIS MANUAL AND ALL THE INSTRUCTIONS THEREIN BEFORE USING THE COOKER. ALSO KEEP THE SERIES OF NOZZLES SUPPLIED. INSTALLATION MUST BE CARRIED OUT BY QUALIFIED PERSONNEL IN ACCORDANCE WITH THE REGULATIONS IN FORCE. THIS APPLIANCE IS INTENDED FOR DOMESTIC USES AND CONFORMS TO CURRENT **REGULATIONS IN FORCE**. THE APPLIANCE HAS BEEN BUILT TO CARRY OUT THE FOLLOWING FUNCTIONS: **COOKING AND HEATING-UP OF FOOD**. ALL OTHER USES ARE CONSIDERED IMPROPER.

THE MANUFACTURER DECLINES ALL RESPONSIBILITY FOR IMPROPER USE.

NEVER USE THIS APPLIANCE FOR HEATING ROOMS.



DO NOT LEAVE THE PACKING IN THE HOME ENVIRONMENT. SEPARATE THE VARIOUS WASTE MATERIALS AND TAKE THEM TO THE NEAREST SPECIAL GARBAGE COLLECTION CENTRE.



REPLACED APPLIANCES MUST BE TAKEN TO A SPECIAL GARBAGE COLLECTION CENTRE.



DO NOT OBSTRUCT VENTILATION OPENINGS AND HEAT DISPERSAL SLITS.



THE I.D. PLATE WITH TECHNICAL DATA, REGISTRATION NUMBER AND BRAND NAME IS VISIBLY POSITIONED IN THE STORAGE COMPARTMENT.

THE PLATE MUST NOT BE REMOVED.



DO NOT USE METALLIC SPONGES OR SHARP SCRAPERS: THEY WILL DAMAGE THE SURFACE.

USE NORMAL NON-ABRASIVE PRODUCTS FOR STEEL, AND A WOODEN OR PLASTIC TOOL IF NECESSARY.

RINSE THOROUGHLY AND DRY WITH A SOFT CLOTH OR DEERSKIN.

DO NOT ALLOW RESIDUES OF SUGARY FOODS (SUCH AS JAM) TO SET INSIDE THE OVEN. IF LEFT TO SET FOR TOO LONG, THEY MIGHT DAMAGE THE ENAMEL LINING OF THE OVEN.



The manufacturer declines all responsibility for damage to persons or things caused by non-observance of the above prescriptions or by interference with any part of the appliance or by the use of non-original spares.

2. DISPOSAL INSTRUCTIONS – OUR ENVIRONMENT POLICY

Our appliances are only packaged using non-pollutant, environment-friendly, recyclable materials. We urge you to cooperate by disposing of the packaging properly. Contact your local dealer or the competent local organisations for the addresses of collection, recycling and disposal facilities.

Never leave all or part of the packaging lying around. Packaging parts, and especially plastic bags, may represent a suffocation hazard for children.

Your old appliance must also be disposed of properly.

Important deliver the appliance to your local organisation authorised to collect scrapped appliances. Proper disposal allows the intelligent recovery of valuable materials. Refrigeration appliances contain gases which may damage the environment; it is important to ensure that the refrigeration circuit pipelines are not damaged until the competent service has taken delivery of the appliance.

Before scrapping your appliances it is important to remove doors and leave shelves in position as for use, to ensure that children cannot accidentally become trapped inside during play. Also, cut the power supply lead and remove it and the plug.

3. SAFETY PRECAUTION



ELECTRICAL CONNECTION: PLEASE REFER TO INSTALLATION INSTRUCTION FOR THE GAS & ELECTRICAL SAFETY REGULATIONS AND THE VENTILATION REQUIREMENTS.

IN YOUR OWN INTEREST, AND THAT OF SAFETY, IT IS THE LAW THAT ALL GAS APPLIANCES BE INSTALLED AND SERVICE BY COMPETENT PERSONS, WHO WILL COMPLY WITH THE RELEVANT STANDARDS AND REGULATIONS.

CORGI REGISTERED INSTALLERS UNDERTAKE TO WORK TO SATISFACTORY STANDARDS. DISCONNECTION OF GAS AND ELECTRIC APPLIANCES SHOULD ALWAYS BE CARRIED OUT BY COMPETENT PERSON.



THE PLUG TO BE CONNECTED TO THE POWER CABLE AND THE SOCKET MUST BE THE SAME TYPE AND MUST CONFORM TO CURRENT REGULATIONS.

THE SOCKET MUST BE ACCESSIBLE AFTER THE APPLIANCE HAS BEEN BUILT IN.

NEVER UNPLUG BY PULLING ON THE CABLE.



DO NOT INSTALL THIS APPLIANCE ON A RAISED PLATFORM.



IT IS COMPULSORY THAT THE APPLIANCE BE GROUNDED ACCORDING TO THE METHODS REQUIRED BY SAFETY RULES.



IMMEDIATELY AFTER INSTALLATION CARRY OUT A BRIEF INSPECTION TEST OF THE APPLIANCE, FOLLOWING THE INSTRUCTIONS BELOW. SHOULD THE APPLIANCE NOT FUNCTION, DISCONNECT IT FROM THE SUPPLY AND CALL THE NEAREST TECHNICAL ASSISTANCE CENTRE.

NEVER ATTEMPT TO REPAIR THE APPLIANCE.



DO NOT PUT PANS WITHOUT PERFECTLY SMOOTH AND FLAT BOTTOMS ON THE HOB GRIDS.



DO NOT USE CONTAINERS OR BROILERS THAT EXTEND BEYOND THE OUTER PERIMETER OF THE HOB.



NEVER PUT INFLAMMABLE OBJECTS IN THE OVEN: THEY COULD BE ACCIDENTALLY LIGHTED AND CAUSE FIRES.



DURING USE THE APPLIANCE BECOMES VERY HOT. TAKE CARE NOT TO TOUCH THE HEATING ELEMENTS INSIDE THE OVEN.



DO NOT SPRAY AEROSOLS IN THE VICINITY OF THIS APPLIANCE WHILE IT IS IN OPERATION.



THE APPLIANCE IS DESIGNED FOR USE BY ADULTS. DO NOT ALLOW CHILDREN TO GO NEAR OR PLAY WITH IT.

WHEN OPERATING THE GRILL ALL ACCESSIBLE PARTS COULD BECOME VERY HOT: **KEEP OUT OF THE WAY OF CHILDREN.**



WHERE THIS APPLIANCE IS INSTALLED IN MARINE CRAFT OR IN CARAVANS, IT SHALL NOT BE USED AS A SPACE HEATER.



WHEN NOT IN USE, MAKE SURE THAT THE CONTROL KNOBS ARE IN THE CORRECT (OFF) POSITION  / .



BEFORE THE APPLIANCE IS PUT INTO OPERATION, ALL THE LABELS AND PROTECTIVE FILMS APPLIED INSIDE OR OUTSIDE MUST BE REMOVED.



4. INTENDED USE OF THE APPLIANCE

THE APPLIANCE HAS BEEN BUILT TO CARRY OUT THE FOLLOWING FUNCTIONS: **COOKING AND HEATING-UP OF FOOD**. ALL OTHER USES ARE CONSIDERED IMPROPER.



The manufacturer declines all responsibility for damage to persons or things caused by non-observance of the above prescriptions or by interference with any part of the appliance or by the use of non-original spares.

5. KNOW YOUR COOKER

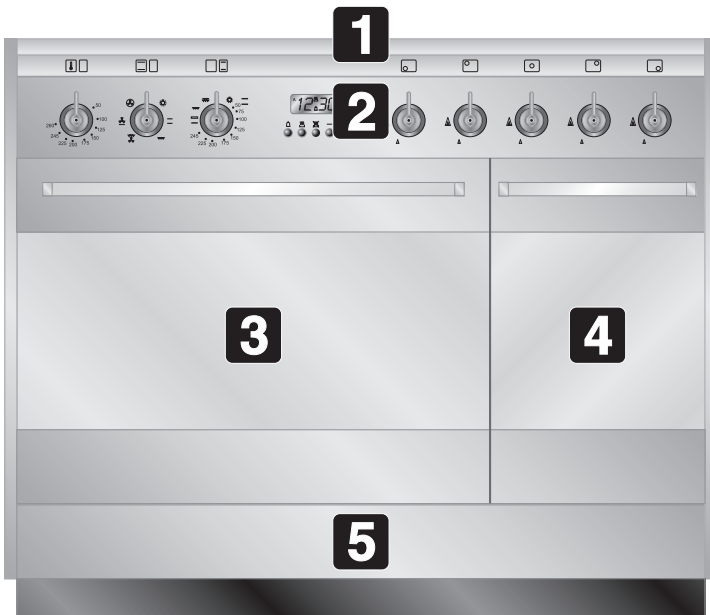

- 1** COOKING HOB
- 2** CONTROL PANEL
- 3** MAIN OVEN
- 4** AUXILIARY OVEN
- 5** STORAGE COMPARTMENT

6. BEFORE FIRST USE



Do not leave the packing in the home environment separate the various waste materials and take them to the nearest special garbage collection centre.



The inside of the appliance should be cleaned to remove all manufacturing residues. For further information about cleaning, see section "11. CLEANING AND MAINTENANCE"



Using the oven and the grill for the first time, heat them to the maximum temperature (**260** or **245°C**) for as long as it takes to burn off any production oil residues which could give a nasty flavour to the food.

After a power cut, the oven display will flash intermittently and show **0:00**. To adjust refer to paragraph "10. ELECTRONIC PROGRAMMER"



Instructions for the user

7. USE OF THE HOB

7.1 Lighting of the hob burners



Before lighting the hob burners check that the flame caps are in the correct position and that their burner caps are in place, making sure that the holes **A** in the flame caps correspond to the spark plugs and thermocouples.



The optional grid **B** is for use with “woks” (Chinese pans).

To prevent deterioration of the hob we have equipped the cooker with a raised pan stand **C** to be placed underneath pans more than 26 cm in diameter.

The supplied reduction rest **C** is used also for small pans.

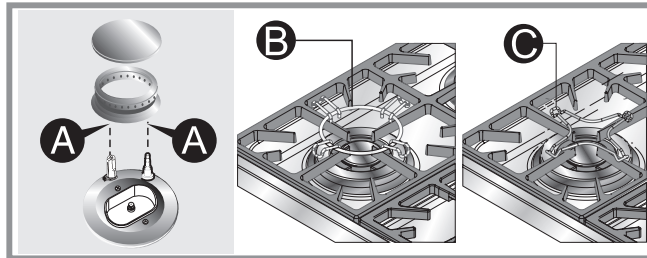

The drawing next to each knob shows the corresponding burner. The appliance has an electronic lighting device. Simply press and turn the knob anticlockwise to the minimum flame symbol Δ , until the flame is lit. Hold the knob down for a few seconds to allow the thermocouples to heat up. The burner may go out when the knob is released: this is because the thermocouple has not been sufficiently heated. Repeat the operation holding down the knob a little longer. This operation is not necessary for burners without thermocouples.

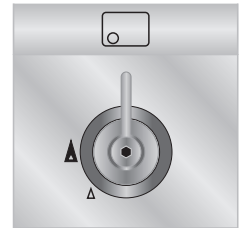

For models with thermocouples, should the burner accidentally go out, a safety device will be activated which stops the gas flow even if the tap is open.

7.2 Practical advice for using the hob burners



For better use of the burners and lower gas consumption, use covered vessel that are proportional in size to the burner to prevent the flame from licking the sides (see paragraph “7.3 Diameter of the vessels to be used on each burner”). When water reaches the boiling point, lower the flame so that it doesn't overflow. To avoid burns or damage to the hob, all vessels or griddle plates must be placed within the perimeter of the hob. All vessels must have a flat and smooth bottom. When using fats or oils, be extremely careful that they don't overheat and catch fire.



If the flame accidentally goes out, turn off the control knob and wait at least 1 minute before trying to re-light the burner.

7.3 Diameter of the vessels to be used on each burner

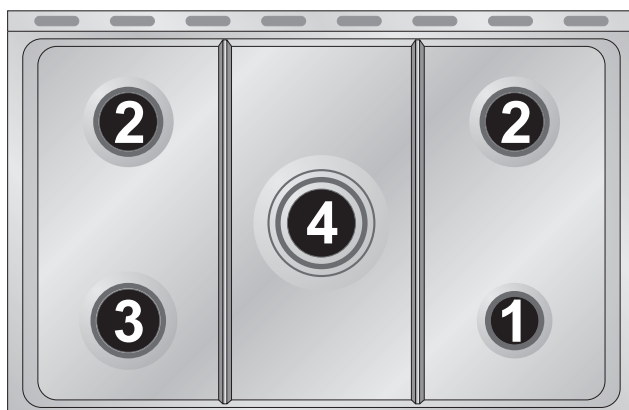

BURNERS

Ø MIN. AND MAX. (IN CM.)







1. Auxiliary	12 - 14
2. Semirapid	16 - 24
3. Rapid	18 - 26
4. Triple Crown	18 - 26

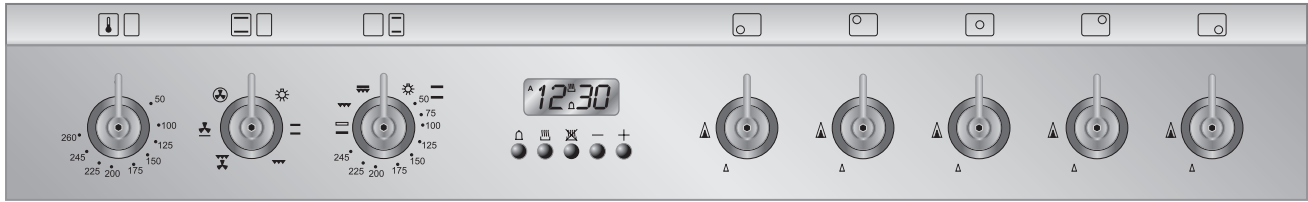





8. FRONT CONTROL PANEL

All the cooker controls and commands are on the front panel.





-   MAIN OVEN THERMOSTAT KNOB
-   MAIN OVEN FUNCTION KNOB
-   AUXILIARY OVEN THERMOSTAT KNOB

-  FRONT LEFT BURNER
-  REAR LEFT BURNER
-  CENTRAL BURNER
-  REAR RIGHT BURNER
-  FRONT RIGHT BURNER



If the cooker is equipped with an electronic programmer, before using the oven make sure that the symbol  ; appears on the display. See paragraph "10. ELECTRONIC PROGRAMMER".

HOB BURNER COMMAND KNOB

The flame is lit by pressing the knob and turning it anticlockwise to minimum flame . To adjust the flame turn the knob between maximum () and minimum (). The burner goes out when the knob is returned to the position.

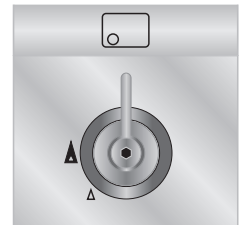

MAIN OVEN THERMOSTAT KNOB

Selection of cooking temperature is carried out by turning the knob clockwise to the required temperature, between 50° and 260°C.

If the appliance has an electric oven, the warning light will come on when the oven is heating up. When it goes out it means that the required temperature has been reached. Regular flashing means that oven temperature is being constantly maintained at the programmed level.

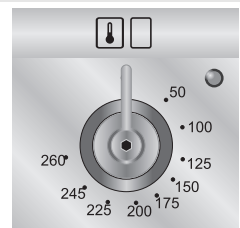

MAIN OVEN CONTROL KNOB

Each of the functions listed below can be used (except the oven light and the small grill) only together with the correct temperature thermostat regulation as described on page of this manual.

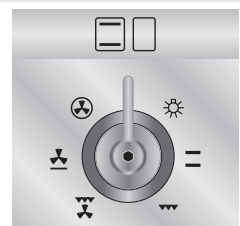



Instructions for the user



OVEN LIGHT



GRILL ELEMENT + VENTILATION



UPPER AND LOWER HEATING ELEMENT



LOWER HEATING ELEMENT + VENTILATION



GRILL ELEMENT



VENTILATED HEATING ELEMENT + VENTILATION

AUXILIARY OVEN THERMOSTAT KNOB

Selection of cooking temperature is carried out by turning the knob clockwise to the required temperature, between 50° and 250°C.

The tell-tale light comes on to indicate that the oven is warming up. When it goes out it means that the required temperature has been reached.

Intermittent going on and off of the light means that oven temperature is being constantly maintained at the programmed level.

The oven is switched on by turning the knob clockwise to any one of the following functions except the oven light:

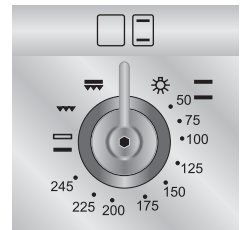

OVEN LIGHT



GRILL ELEMENT



UPPER AND LOWER HEATING ELEMENT
50 ÷ 245°



UPPER HEATING ELEMENT AND GRILL
ELEMENT



LOWER HEATING ELEMENT



9. USE OF THE OVENS

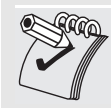

For the models with electronic programmer, before using the oven make sure that the display shows the symbol .

9.1 Warnings and general advice

Using the oven and the grill for the first time, heat them to the maximum temperature (260-245°C) for as long as it takes to burn off any production oil residues which could give a nasty flavour to the food. After a power cut, the oven display will flash intermittently and show **0:00**. To adjust refer to paragraph "10. ELECTRONIC PROGRAMMER"



Oven accessories which may come into contact with foods are made from materials complying with the requirements of the current directive.

To prevent problems caused by steam in the oven, open the door in two stages: half open (5 cm approx.) for 4-5 seconds and then fully open.
To access food, always leave the door open as short a time as possible to prevent the temperature in the oven from falling and ruining the food.





9.2 Cooling system

The oven is equipped with a cooling system which automatically comes on upon a few minutes after the oven has been turned on.

Fans cause a steady outflow of air from above the door which may continue for a brief period of time even after the oven has been turned off.

9.3 Use of the electric grill in the large oven

For short cooking procedures, such as the final crisping of meat which is already cooked, select the static grill function  and turn the thermostat knob to the maximum temperature. The fan grill function allows actual cooking procedures to be carried out, thanks to the fan function which ensures that the heat penetrates into the food. For this cooking mode, select the fan grill function  (and turn the thermostat knob to the ideal cooking temperature (never set at more than 200° C).

9.4 Use of the electric grill in the auxiliary oven

For short cooking procedures, such as the final crisping of meat which is already cooked, select the static grill function .

9.5 How to use the grill



Once the grill is lit, the red warning light will come on. Leave the oven to heat up for five minutes before placing the food inside.

Food should be flavoured and basted with oil or melted butter before cooking. An oven dish should be used to contain the sauces. The food should be placed on the oven shelf which is positioned on one of the guides supplied with the different ovens, following the instructions below:



FOOD	GRILLE ON THE SHELF
Flat or thin meat	3
Rolled roast joints	2 - 3
Poultry	2 - 3



Instructions for the user

9.6 WARNING



- Cooking procedures in this mode must never last more than 60 minutes.
- In models with gas oven, the door must be half-open on the first catch during grilling and grill-rotisserie cooking.
- In models with electric oven, the door must be close during grilling and grill-rotisserie cooking.
- To avoid dangerous overheating when the oven or the grill is used, the glass cover must always be up. The electric grill and the gas oven cannot be used at the same time.
- During and after use the accessible parts of the oven may be very hot, and children must always be kept at a distance.
- During cooking with the rotisserie, one of the oven trays provided with the cooker should be placed in the bottom of the oven, inserting it on the bottom runners, in order to collect the grease and fats which may be formed.
- During cooking, do not cover the bottom of the oven with aluminium or tin foil and do not place pans or oven trays on it as this may damage the enamel coating. If you wish to use greaseproof paper, place it so that it will not interfere with the hot air circulation inside the oven.
- When using the oven, remove all unused baking sheets and shelves from the interior.

9.7 Storage compartment

A storage compartment, accessible by pulling on the top edge of the door, is located beneath the oven.

Never store flammable materials such as rags, paper or the like. The compartment is intended only for holding the metal accessories of the range.



Never open the storage compartment when the oven is on and still hot. The temperature inside may be very high.







10. ELECTRONIC PROGRAMMER







The programmer user instructions are valid only for the **main oven**.



LIST OF FUNCTIONS

-  MINUTE-COUNTER KEY
-  COOKING TIME KEY
-  END OF COOKING KEY
-  DECREASE TIME KEY
-  INCREASE TIME KEY



10.1 Clock adjustment



When using the oven for the first time, or after a power failure, the display flashes regularly and indicates **0:00**. Press the keys  and  and at the same time the keys  or : each single press changes the time by 1 minute either up or down.



Before setting the programmer activate the desired function and temperature.



10.2 Semiautomatic cooking



Use this setting for automatic oven switch-off at the end of cooking time. By pressing key  the display lights up, showing **0:00**; keep the key pressed and at the same time, press keys  or  to set the cooking time.



Release key  to start the programmed cooking time count. The display will now show the right time together with symbols **A** and .

10.3 Automatic cooking



Use this setting to automatically start and stop the oven.

By pressing key  the display lights up showing **0:00**; keep the key pressed and at the same time, press keys  or  to set the cooking time.

By pressing key  the sum of the right time + cooking time will appear; keep the key pressed and at the same time, press keys  or  regulate the end of cooking time.

Release key  to start the programmed count and the display will show the right time together with symbols **A** and .



After set-up, to see the cooking time remaining, press the key ; to see the end of cooking time press the key . Set-up with incoherent values is logically prevented (e.g. the contrast between a cooking time and a longer period will not be accepted by the programmer).





10.4 End of cooking

When cooking is over, the oven will automatically switch off and, at the same time, an intermittent alarm will sound. After switching off the alarm, the display will once again show the right time together with the symbol , indicating that the oven has returned to manual operation mode.



Instructions for the user

10.5 Minute Counter

The programmer can also be used as a simple minute counter. By pressing key  the display shows ; keep the key pressed and at the same time press keys  or . On releasing the key  programmed counting will begin and the display will show the current time and the symbol.





After set-up, to see the remaining time, press the key . Use as a minute counter does not interrupt functioning of the oven at the end of the programmed time.



10.6 Adjusting alarm volume

The acoustic alarm has three different settings. These can be operated, while the alarm is sounding, by pressing key .



10.7 Switching off the alarm

The alarm switches off automatically after seven minutes. They can be manually de-activated by pressing the keys  and  together. **To switch off the appliance, rotate all the knobs to position 0.**

10.8 Cancellation of set data

Once the programme has been set, keep the key of the function to be cancelled pressed, while at the same time  is reached by means of variation keys  or . Time cancellation will be considered as end-of-cooking time by the programmer.

10.9 Changing the set data

The cooking data entered can be changed at any time by keeping the function key pressed and at the same time adjusting the keys  or .



11. CLEANING AND MAINTENANCE

NEVER USE A STEAM JET TO CLEAN THE APPLIANCE.



11.1 Cleaning stainless steel

To maintain stainless steel in good condition clean it regularly after each use, once it has cooled down.



11.2 Ordinary daily cleaning

To clean and preserve the stainless steel surfaces, always use **only** specific products that do not contain abrasives or chlorine-based acids.

How to use: pour the product on a damp cloth and wipe the surface, rinse thoroughly and dry with a soft cloth or deerskin.

11.3 Food stains or residues

Do not use metallic sponges or sharp scrapers: they will damage the surface.

Use normal non-abrasive products for steel, and a wooden or plastic tool if necessary.

Rinse thoroughly and dry with a soft cloth or deerskin.

Do not allow residues of sugary foods (such as jam) to set inside the oven. If left to set for too long, they might damage the enamel lining of the oven.



11.4 Cleaning of the hob components

11.4.1 Grids

Remove the grids and clean them in warm water with a non-abrasive detergent, taking care to remove any encrustations. Replace them on the hob.

Continuous contact of the grids with the flame can cause the enamel near the hot areas to be altered. This is completely natural and does not compromise the functionality of the component.

11.4.2 Burner caps and flame cap crowns

The caps and flame-spreader crowns are extractable to facilitate cleaning. Wash them in hot water with non-abrasive detergent, taking care to remove any encrustations, and wait until they are **perfectly dry**.

WARNING: do not wash these components in the dishwasher.

The burners can be left to soak in hot water and detergent.



Replace the flame-spreader crowns, checking that they are positioned in their housing with their respective caps, taking care that flame-spreader holes **A** correspond to the spark plugs and the thermocouples.

11.4.3 The spark plugs and thermocouples

To function properly the spark plugs and thermocouples must always be clean (on the models which are equipped with them). Check them regularly and clean with a damp cloth if necessary. Any dry residues can be removed with a toothpick or a needle.





Instructions for the user

11.5 Cleaning of oven



For best oven upkeep clean regularly after having allowed to cool. Take out all removable parts.

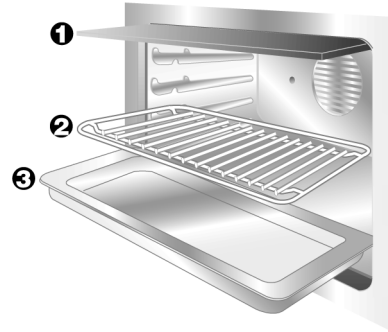
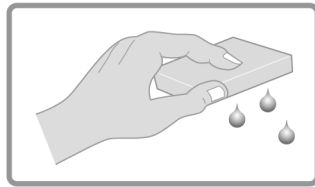

- Clean the oven grill with hot water and non-abrasive detergent. Rinse and dry.
- Do not allow residues of sugary foods (such as jam) to set inside the oven. If left to set for too long, they might damage the enamel lining of the oven.

11.6 Door glass

The door glass should always be kept clean. Use absorbent kitchen paper to clean. In case of tough spots, clean with a damp sponge using regular detergent.

When cleaning, the appliance must be dried thoroughly since detergent and water drips might damage its operation and appearance.





12. EXTRAORDINARY MAINTENANCE

The oven may require extraordinary maintenance or replacement of parts subject to wear such as seals, bulbs, and so on. The following instructions describe how to carry out these minor maintenance operations.

Before any intervention, disconnect the power supply of the device.



12.1 Lubrication of the taps



In time the taps may be difficult to turn or may be blocked. Clean them inside and replace the lubrication grease. This operation should be carried out by a specialised technician.

12.2 Replacement of light bulb

Remove cover **A** by twisting anticlockwise, replace bulb **B** with another similar bulb (25 W). Refit the cover **A**.

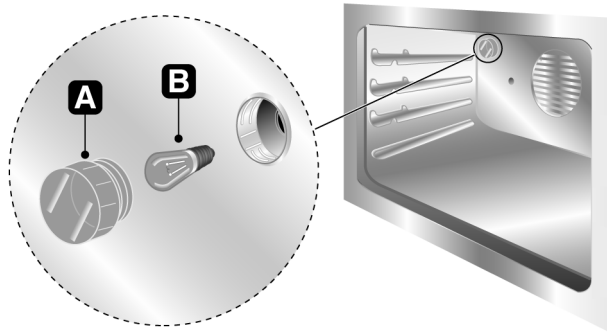

Only use oven bulbs (T 300°C).

12.3 Removing the door

Hold the door on both sides with both hands near hinges **A** and raise levers **B**. Lift up the door forming an angle of about 45° and remove. To refit, slide the hinges **A** in the grooves, drop the door and release levers **B**.

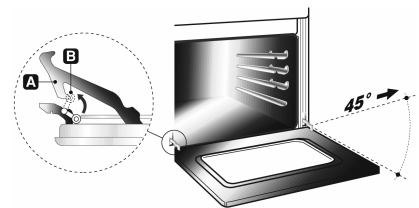

12.4 Oven door seal

To permit thorough cleaning of the oven, the seal may be removed. Before removing the seal, take off the door as described above. Once the door has been taken off, lift the tabs at the corners as shown in the figure.

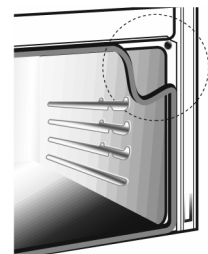



Instructions for the installer

13. INSTALLATION OF THE APPLIANCE



It is the law that all gas appliances are installed by **authorised persons**. Clearance around the cooker must comply with the requirements of AS5601.

13.1 Electrical connection



Make sure that the power line voltage matches the specifications indicated on the rating plate located inside the storage compartment.

This rating plate must never be removed.



On the power line, install a two-pole cut-off device with contact cut-off distance greater than or equal to **3 mm**, located in an easily accessible position near the unit.

The connection terminals are located at the rear of the appliance. For electrical connections see following diagram. To access, remove the rear cover.

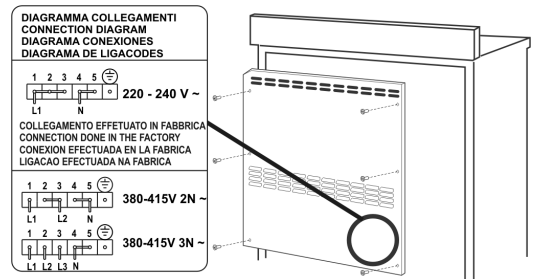

For operation on 380-415V3N (only for 90 cm models): use an H05RR-F / H05RN-F / H05V2V2-F type five-core cable (5 x 1.5 mm²).

For operation on 380-415V2N (only for 90 cm models): use an H05RR-F / H05RN-F / H05V2V2-F type five-core cable (cavo di 4 x 1.5 mm²)

For operation on 220-240V : use an H05RR-F / H05RN-F / H05V2V2-F (3 x 2.5 mm²).

The cable end to be connected to the appliance must be provided with an ground wire (yellow-green) at least 20 mm longer.

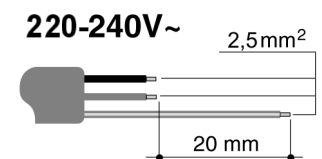
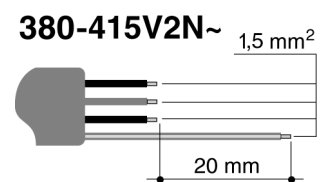
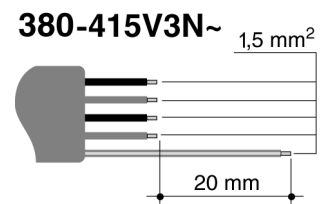

The manufacturer declines all responsibility for damage to persons or things caused by non-observance of the above prescriptions.



Overall dimensions: location of gas and electrical connection points (all measures in mm).

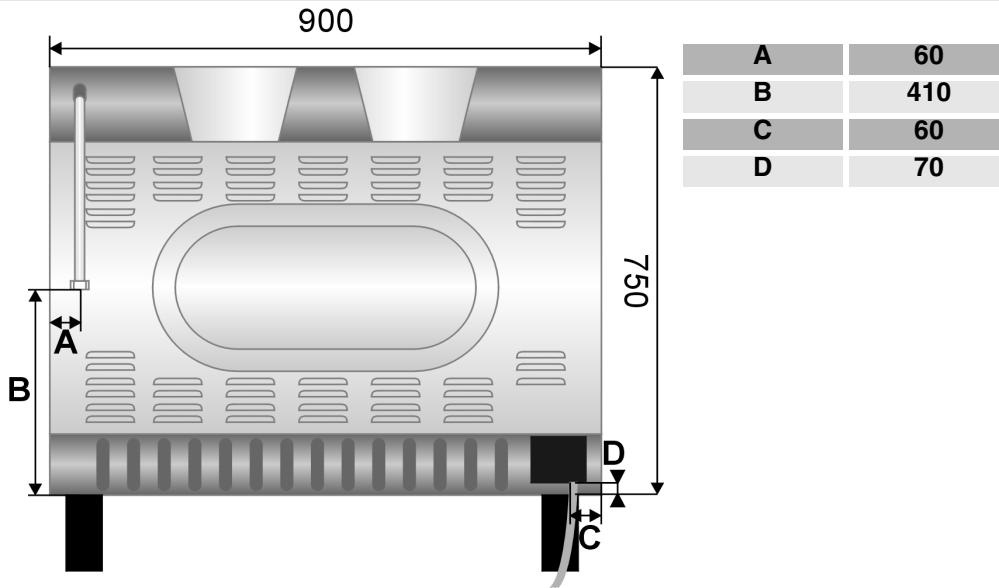

13.2 Gas connection

This appliance is suitable for installation with Natural Gas or ULPG (propane). Refer to page 12 for the relevant burner pressure and appropriate injector sizes. When the appliance is to be connected to Natural Gas then the pressure regulator supplied must be fitted to the gas inlet. A test point (for checking the gas pressure) is supplied either with the regulator or as a separate fitting in the case of ULPG (propane) appliances.

Connection of the appliance to the gas supply must be in accordance with the requirements of AS5601. A 1/2" BSP connector at the inlet is recommended and the gas supply line to the appliance must be of adequate length to allow sufficient withdrawal of appliance for service or disconnection and be annealed copper pipe.

The cooker must be installed with provision to allow the gas to be turned off and disconnected for servicing and removal of the appliance as required from the gas supply.

Before the cooker is operated make certain all relevant parts are placed in the correct position.

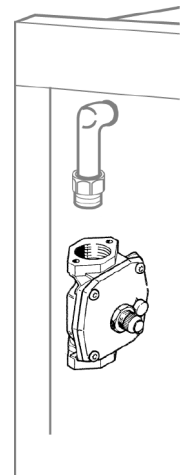

When the installation is completed the installation connections of cooker will require to be leak tested, the burner operating pressure and flame checked and adjusted.

Warranty service calls do not cover these adjustments!

To check the operating pressure of the appliance it is recommended at least 2 large size burners are used. Ensure appliance is secured to wall when installation is completed.

N.G. The regulator supplied must be fitted to the 1/2 BSP thread at the rear of the appliance. An approved manual shut-off valve must be installed. The N.G. regulator must be checked and adjusted to 1.0 kPa after installation.

L.P.G. Can be connected to the inlet fitting directly. The pressure must be checked to ensure it is operating at 2.75 kPa. A separate test point fitting must be installed between the piping & the appliance for the pressure to be checked to ensure it is operating at 2.75 kPa.

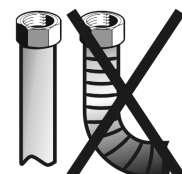



Instructions for the installer

13.3 Room ventilation



Caution – This cooker may only be installed and operated in rooms permanently ventilated in accordance with current regulations. For proper operation of a gas appliance it is essential for the air necessary for combustion of the gas to be able to flow naturally into the room. Air must flow directly into the room through openings in its outside walls.

This (these) opening (s) must have a free passage cross-section of at least 100 cm², or 200 cm² for appliances not equipped with gas safety device. These openings must be constructed so that they cannot be obstructed indoors or outdoors, and should preferably be close to the floor on the side opposite to the combustion gas discharge point. If it is not possible to make the openings in the room where the cooker is installed, the necessary air may be taken from an adjoining room, provided it is not a bedroom or a room with fire risk.

13.4 Clearance above and around domestic cookers

Extract from AS5601

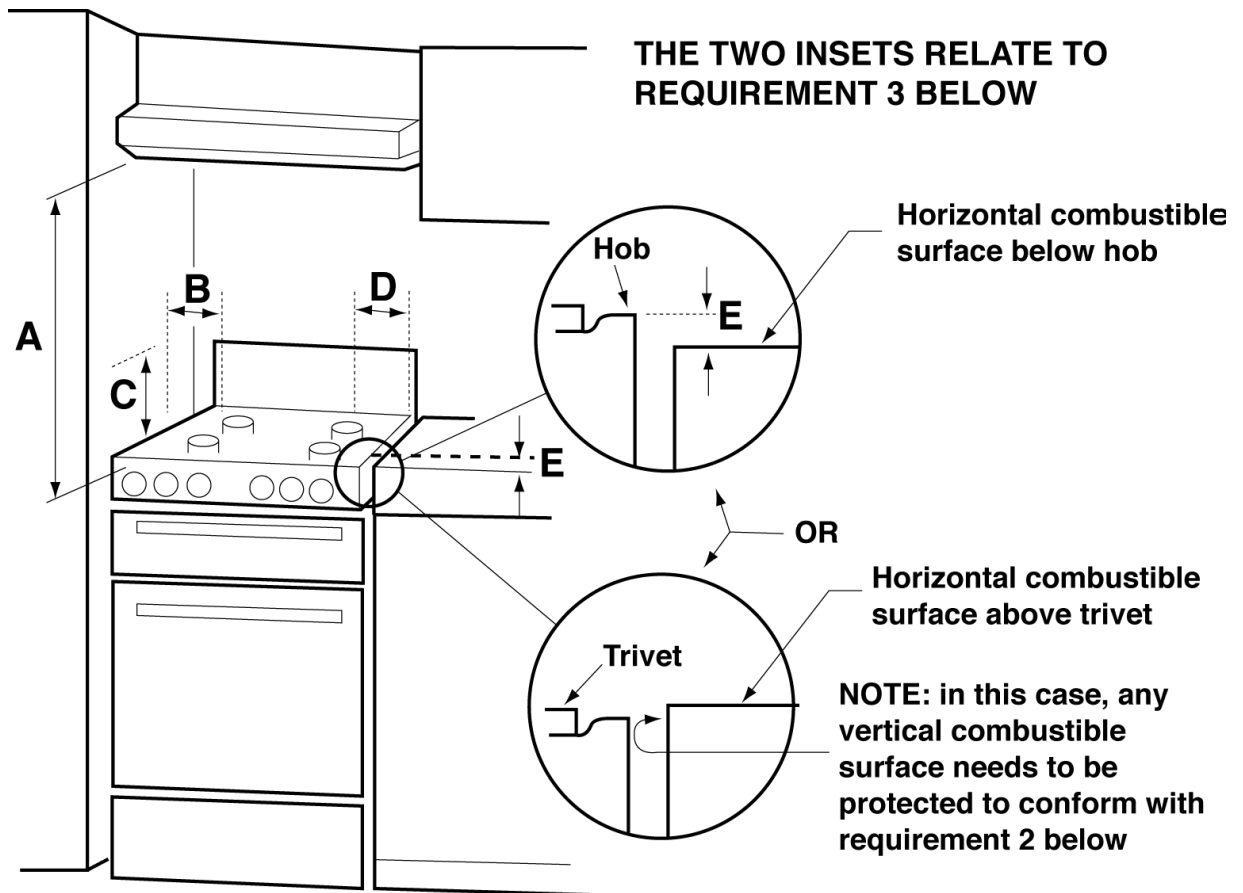



REQUIREMENTS

1 Overhead clearances – (Measurement **A**)

Range hoods and exhaust fans shall be installed in accordance with the manufacturer's instructions. However, in no case shall the clearance between the highest part of the *hob* of the cooking *appliance* and a *range hood* be less than **600 mm** or, for an overhead exhaust fan, **750 mm**.

Any other downward facing *combustible surface* less than **600 mm** above the highest part of the *hob* shall be protected for the full width and depth of the cooking surface area in accordance with Clause 5.12.1.2. However, in no case shall this clearance to any surface be less than **450 mm**.

2 Side clearances – (Measurements **B** & **C**)

Where **B**, measured from the periphery of the nearest *burner* to any vertical *combustible surface*, is less than **200 mm**, the surface shall be protected in accordance with Clause 5.12.1.2 to a height **C** of not less than **150 mm** above the *hob* for the full dimension (width or depth) of the cooking surface area. Where the cooking *appliance* is fitted with a 'splashback', protection of the rear wall is not required.

3 Additional requirements for Freestanding and Elevated Cooking Appliances – (Measurements **D** & **E**)

Where **D**, the distance from the periphery of the nearest *burner* to a horizontal *combustible surface* is less than **200 mm**, then **E** shall be **10 mm** or more, or the horizontal surface shall be above the *trivet*.

See insets above.

NOTES

- 1 Requirement 3 does not apply to a freestanding or elevated cooking appliance which is designed to prevent flames or the cooking vessels from extending beyond the periphery of the appliance.
- 2 The 'cooking surface area' is defined as that part of the appliance where cooking normally takes place and does not include those parts of the appliance containing control knobs.
- 3 For definition of hob, see Clause 1.4.64.
- 4 For definition of trivet, see Clause 1.4.109.
- 5 Consideration is to be given to window treatments when located near cooking appliances. See Clause 5.3.4.



Instructions for the installer

14. ADAPTATION TO DIFFERENT TYPES OF GAS

Before performing any cleaning or maintenance work, disconnect the appliance from the mains.



The hob of the cooker is adjusted for use with **natural gas** at a pressure of 1.0kPa. If used with other types of gas, you have to replace the nozzles and regulate the primary air to the burners. Then adjust the minimum flame on the gas taps. For nozzle replacement and burner adjustment you must raise the hob as described in the following paragraph.

14.1 Replacement of nozzles on the hob

- 1 Extract the grids and remove all the caps and flame-spreader crowns;
- 2 Unscrew the burner nozzles with a 7 mm socket wrench;
- 3 Replace the nozzles according to the type of gas to be used and the description in paragraph "14.2 Burner and nozzle characteristics table";
- 4 Replace the burners in the correct position.

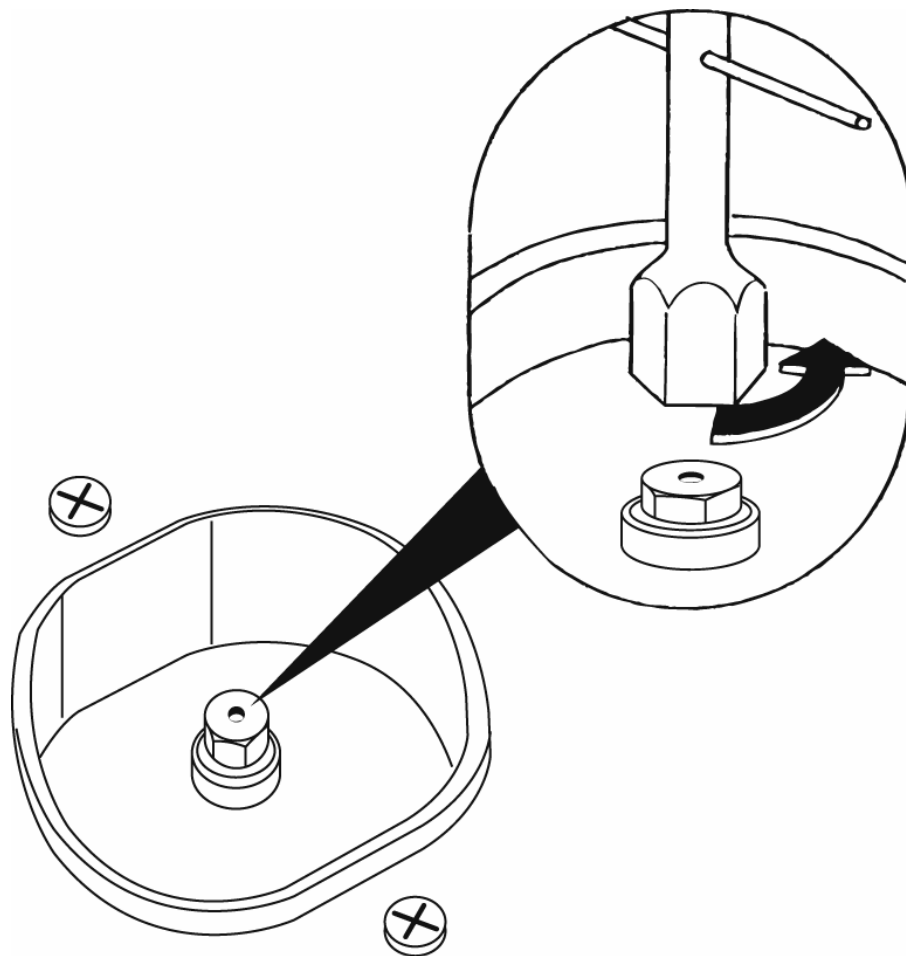



14.2 Burner and nozzle characteristics table

Burner	ULPG (PROPANE) – 2.75 kPa		
	Nominal gas consumption (MJ/h)	Turn-down gas consumption (MJ/h)	Injector (mm)
Auxiliary	3.9	1.5	0.54
Semi rapid	6.3	1.5	0.68
Rapid	10.0	2.7	0.88
Triple crown	12.8	5.4	1.00

Burner	NG – 1.0 kPa		
	Nominal gas consumption (MJ/h)	Turn-down gas consumption (MJ/h)	Injector (mm)
Auxiliary	3.9	1.5	0.90
Semi rapid	6.5	1.5	1.20
Rapid	12	2.7	1.55
Triple crown	15	5.4	1.75

14.3 Arrangement of the burners on the hob

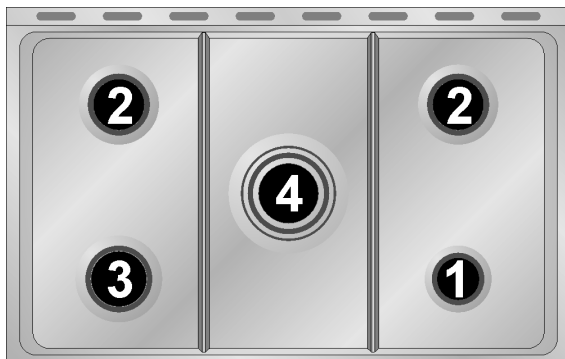

BURNERS

BURNERS	ø min e max (in cm.)
1 Auxiliary	12 - 14
2 Semi rapid	16 - 24
3 Rapid	18 - 26
4 Triple crown	18 - 26



Instructions for the installer

15.FINAL OPERATIONS

After replacing the nozzles, reposition the flame-spreader crowns, the burner caps and the grids.



Following adjustment to a gas other than the preset one, replace the gas adjustment label fixed to the appliance with the one corresponding to the new gas. This label is in the packet together with the nozzles.

15.1 Regulation of the hob burner minimum level for natural gas

Light the burner and turn it to the minimum position Δ . Extract the gas tap knob and turn the adjustment screw at the side of the tap rod until the correct minimum flame is achieved.

Replace the knob and check burner flame stability: (rapidly turning the knob from maximum to minimum position, the flame should not go out). Repeat the operation on all the gas taps.

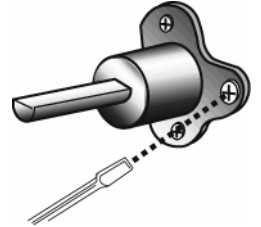

For models with valves, keep the knob at minimum level for about 1 minute to keep the flame lit and to activate the safety device.

15.2 Regulation of the hob burner minimum level for ULPG

In order to adjust the minimum with ULPG, the screw at the side of the tap rod must be turned clockwise all the way.

The bypass diameters for each individual burner are shown in paragraph "14.2 Burner and nozzle characteristics table". Once the regulation has been completed, restore the seal on the by-passes using paint or similar materials.

15.3 Mounting the rear top skirtboard (where applicable)

- Loosen nuts **B**.
- Position the skirt above the top, taking care to align pins **C** with holes **D**.
- Secure the skirt to the top by tightening screws **A**.

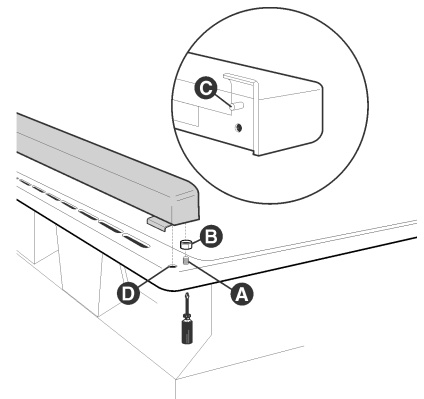



15.4 Wall fixing



In order to prevent accidental tipping of the appliance, for example by a child climbing onto the open oven door, a stabilizing means must be installed. Please refer to instructions for installation.

- Stretch out the chain attached to the cooker horizontally so that the other end touches the wall.
- Mark the wall in the position where the hole is to be drilled.
- Drill the hole, insert a wall plug and attach the chain.
- Move the cooker up against the wall.

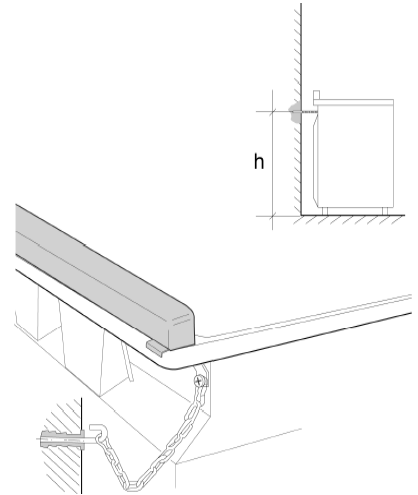



914773014/ B