

Table of contents

1. Precautions for safety and use	4
2. Fitting the appliance in the top	5
2.1 Fixing to the supporting structure	5
3. Electrical connection	7
3.1 Clearance above and around domestic appliances	8
3.2 Room ventilation	9
3.3 Discharge of combustion products	9
4. GAS CONNECTION	10
5. Adapting to different types of gas	11
5.1 Removing the hob skin	11
5.2 Adjusting for bottled gas	12
5.3 Adjusting for natural gas	12
5.4 Adjusting the primary air flow	13
5.5 Reassembling the hob skin	13
5.6 Adjusting the minimum setting for natural gas and town gas	13
5.7 Adjusting the minimum for bottled gas	13
5.8 Hob burner layout	14
5.9 Greasing the gas taps	14
6. Description of controls	15
6.1 The front panel	15
7. Using the hob	16
7.1 Lighting burners with safety device	16
7.2 Positioning the griddle plate	16
7.3 Practical hints for using the burners	16
7.4 Pan diameters	17
8. Cleaning and maintenance	18
8.1 Cleaning stainless steel	18
8.2 Cleaning the components	18

THESE INSTRUCTIONS ONLY APPLY TO THE COUNTRIES OF DESTINATION WHOSE IDENTIFICATION SYMBOLS ARE LISTED ON THE COVER OF THIS MANUAL.
THIS BUILT-IN HOB IS CLASSIFIED AS CLASS 3.



INSTRUCTIONS FOR THE INSTALLER: these are intended for the **authorised person** who is to check the gas supply system and install, commission and test the appliance.



INSTRUCTIONS FOR THE USER: these provide recommendations for use, a description of the controls and the correct procedures for cleaning and maintaining the appliance.

Precautions for Safety and Use

1. Precautions for safety and use



THIS MANUAL IS AN INTEGRAL PART OF THE APPLIANCE. TAKE GOOD CARE OF IT AND KEEP IT TO HAND THROUGHOUT THE HOB'S LIFE CYCLE. USERS ARE ADVISED TO READ THIS MANUAL AND ALL THE INSTRUCTIONS IT CONTAINS BEFORE USING THE HOB. ALSO KEEP THE SET OF NOZZLES PROVIDED IN A SAFE PLACE. INSTALLATION MUST BE CARRIED OUT BY QUALIFIED STAFF IN COMPLIANCE WITH THE RELEVANT REGULATIONS. THIS APPLIANCE IS INTENDED FOR HOUSEHOLD USE AND COMPLIES WITH THE EEC DIRECTIVES CURRENTLY IN FORCE. THE APPLIANCE IS BUILT TO PROVIDE THE FOLLOWING FUNCTION: **COOKING AND HEATING FOODS**; ALL OTHER USES ARE TO BE CONSIDERED IMPROPER.

THE MANUFACTURER DECLINES ALL LIABILITY FOR USES OTHER THAN THOSE STATED ABOVE.



NEVER LEAVE PACKAGING RESIDUES UNATTENDED IN THE HOME. SEPARATE WASTE PACKAGING MATERIALS BY TYPE AND CONSIGN THEM TO THE NEAREST SEPARATE DISPOSAL CENTRE.



THE APPLIANCE MUST BE CONNECTED TO EARTH IN COMPLIANCE WITH ELECTRICAL SYSTEM SAFETY REGULATIONS.



THE PLUG TO BE CONNECTED TO THE POWER SUPPLY LEAD AND THE RELATIVE SOCKET MUST BE OF THE SAME TYPE AND COMPLY WITH THE RELEVANT REGULATIONS.

THE POWER SUPPLY SOCKET MUST BE ACCESSIBLE EVEN AFTER THE APPLIANCE HAS BEEN BUILT-IN. **NEVER DISCONNECT THE PLUG BY PULLING ON THE POWER SUPPLY LEAD.**



IMMEDIATELY AFTER INSTALLATION, CARRY OUT A QUICK TEST ON THE HOB FOLLOWING THE INSTRUCTIONS PROVIDED LATER IN THIS MANUAL. IF THE APPLIANCE FAILS TO OPERATE, DISCONNECT IT FROM THE ELECTRICAL MAINS AND CONTACT YOUR NEAREST SERVICE CENTRE. **NEVER ATTEMPT TO REPAIR THE APPLIANCE YOURSELF.**



AFTER EACH USE OF THE HOB, ALWAYS CHECK THAT THE CONTROL KNOBS ARE TURNED TO "ZERO" (OFF).



NEVER PLACE PANS WITH BOTTOMS WHICH ARE NOT PERFECTLY FLAT AND SMOOTH ON THE HOB PAN STANDS.



NEVER USE PANS OR GRIDDLE PLATES WHICH PROJECT BEYOND THE OUTSIDE EDGE OF THE HOB.



THE NAMEPLATE WITH THE TECHNICAL DATA, SERIAL NUMBER AND MARK IS IN A VISIBLE POSITION UNDERNEATH THE CASING, ANNEXED TO THIS MANUAL AND APPLIED TO THE QUALITY CERTIFICATE. **THIS NAMEPLATE MUST NEVER BE REMOVED.**



DO NOT SPRAY AEROSOLS IN THE VICINITY OF THIS APPLIANCE WHILE IT IS IN OPERATION



THIS APPLIANCE IS DESIGNED FOR COOKING FOOD AND IT SHALL NOT BE USED AS A SPACE HEATER.



WHERE THIS APPLIANCE IS INSTALLED IN MARINE CRAFT OR IN CARAVANS, IT SHALL NOT BE USED AS A SPACE HEATER



THE APPLIANCE IS INTENDED FOR USE BY ADULTS. KEEP CHILDREN AT A SAFE DISTANCE AND NEVER ALLOW THEM TO PLAY WITH IT.



The manufacturer declines all responsibility for injury or damage caused by failure to comply with the above regulations or deriving from tampering with even just one part of the appliance and the use of non-original spare parts.

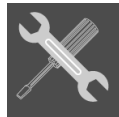

2. Fitting the appliance in the top



The procedures required below must be carried out by a skilled builder and/or joiner. The hob can be installed on various materials, including masonry, metal, solid wood and wood finished with plastic laminates, provided the material is heat-resistant ($T 90^{\circ} C$).

2.1 Fixing to the supporting structure

Make a hole in the cabinet top with the dimensions shown here, maintaining a distance of at least **70 mm** from the rear edge. This appliance may be installed against lateral walls higher than the worktop surface, provided the distance "X" shown here is maintained, in order to prevent damage due to overheating. Make sure that there is at least **650 mm** between the hob burners and a shelf or hood (if any) placed vertically above them.

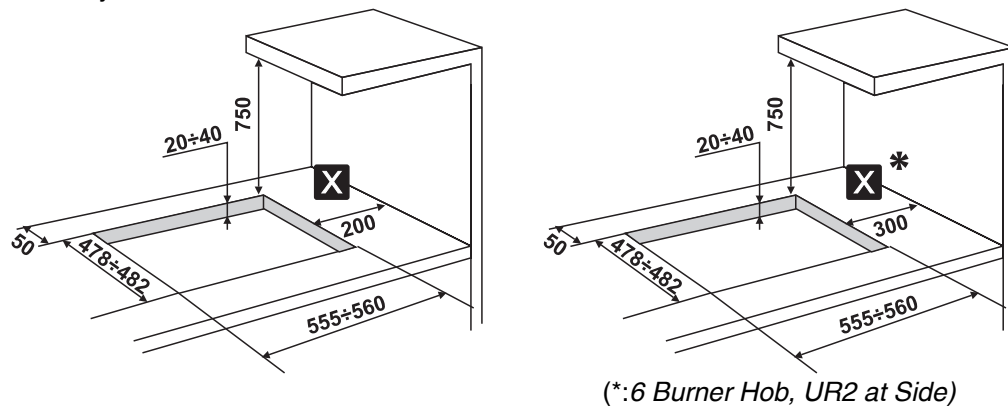

If the hob is installed above a cupboard with doors, a separator panel must be installed underneath it. Leave a gap of at least 20 mm between the bottom of the hob and the surface of the panel, which must be easily removable to allow sufficient access for any servicing procedures.

IMPORTANT: when installing the appliance above a cupboard, a dividing shelf, as shown above, must be installed.

If installed above an under-bench oven, this is not required.

Installation of an oven without cooking fan underneath the hob is forbidden.

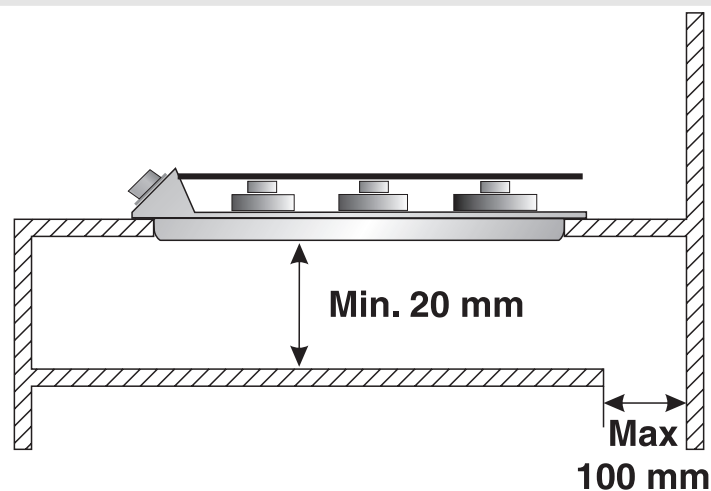

Fit the insulating gasket provided carefully around the outside edge of the hole made in the top as shown below, pressing it down with your hands so that its entire surface fits snugly. Follow the dimensions shown, depending on the model of hob to be installed, bearing in mind that on both models the long front edge must be flush with the hole. Fix the hob to the structure using the brackets **A** provided. Carefully trim off the excess



Instructions for the Installer

edge of the gasket **B**. The dimensions in the drawing below refer to the hole **on the inside edge** of the gasket.

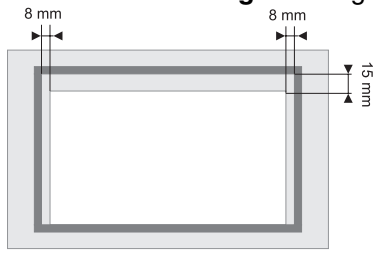

MOD.60

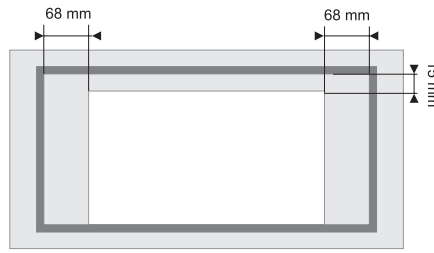

MOD.70

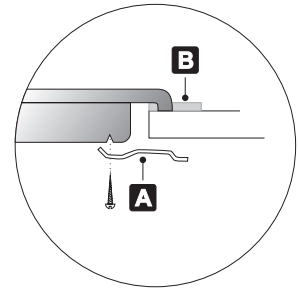

*In case of installation on a hollow compartment with doors, a separating panel has to be placed under the hob. Keep a minimum distance of **10 mm** between the bottom of the unit and the panel surface. The panel has to be easily removable to allow access in the event of technical service.*

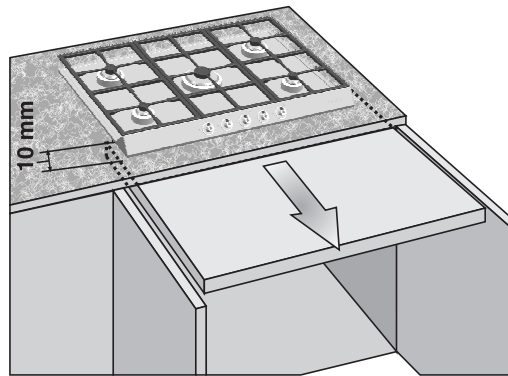

See right for the precise holes to be used when securing the hob to the top correctly using the brackets.

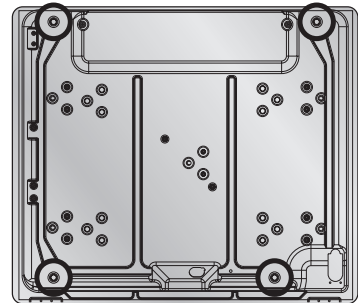

Overall dimensions: location of gas and electrical connection points (all measures in mm).

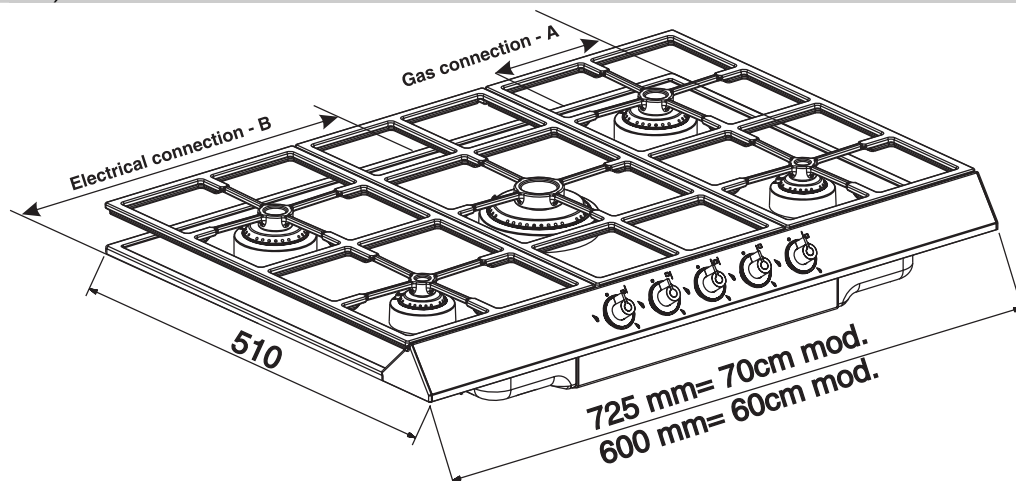

60 cm mod.	70 cm mod.
A	B
14	6
35	30



3. Electrical connection



Check that the power supply line voltage and size are as specified on the nameplate underneath the appliance's casing. **This nameplate must never be removed.**



The plug on the end of the power supply lead and the wall socket must be of the same type and comply with the relevant regulations. Check that the power supply line is properly earthed.



Pass the power supply cable through the rear of the cabinet, taking care that it does not touch the bottom case of the hob, or the oven (if any) built in underneath it.



The appliance's power supply line must be fitted with an omnipolar breaking device with contact gap of at least **3 mm**, located in an easily accessible position close to the appliance itself.



The use of reductions, adapters or junctions is not recommended.



If the power supply cable has to be replaced, the gauge of the wires in the new cable must be at least 0.75 mm^2 (3 x 0.75 cable), bearing in mind that the earth wire (yellow-green) must be at least 20 mm longer at the end for connection to the appliance. Use only a type H05V2V2-F or similar cable resistant to a temperature of up to 90°C . The cable must be replaced by a qualified electrician, who must make the mains connection as shown below.

L = brown

N = blue

 = yellow-green

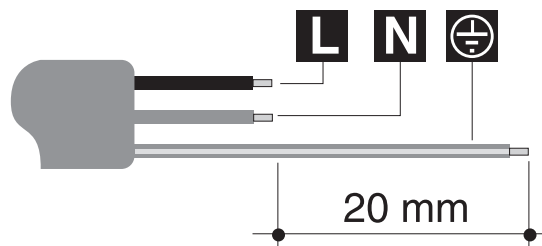

The power supply lead must be replaced by an authorised service centre to prevent all risks.



The manufacturer declines all responsibility for injury or damage caused by failure to comply with the above regulations or deriving from tampering with even just one part of the appliance.



Instructions for the Installer

3.1 Clearance above and around domestic appliances

Extract from AS5601

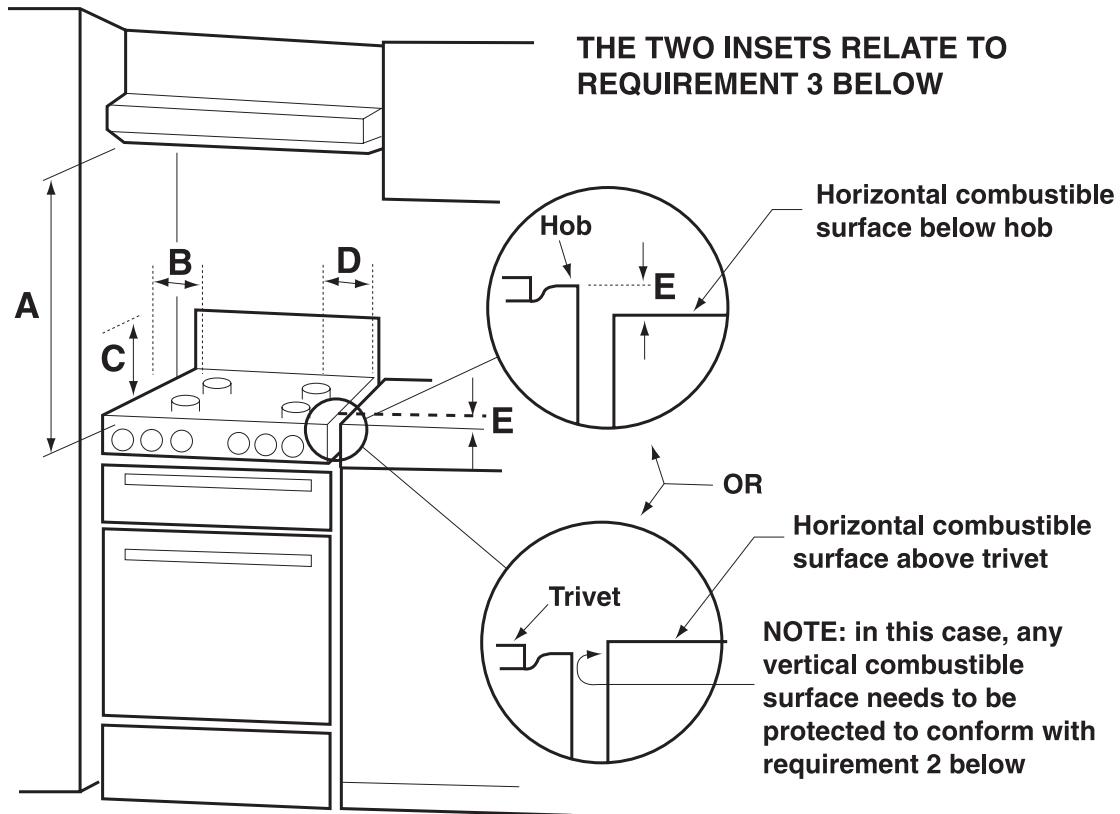

REQUIREMENTS

1 Overhead clearances – (Measurement A)

Range hoods and exhaust fans shall be installed in accordance with the manufacturer's instructions. However, in no case shall the clearance between the highest part of the *hob* of the cooking *appliance* and a *range hood* be less than **600 mm** or, for an overhead exhaust fan, **750 mm**.

Any other downward facing *combustible surface* less than **600 mm** above the highest part of the *hob* shall be protected for the full width and depth of the cooking surface area in accordance with Clause 5.12.1.2. However, in no case shall this clearance to any surface be less than **450 mm**.

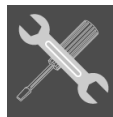

2 Side clearances – (Measurements B & C)

Where **B**, measured from the periphery of the nearest *burner* to any vertical *combustible surface*, is less than **200 mm**, the surface shall be protected in accordance with Clause 5.12.1.2 to a height **C** of not less than **150 mm** above the *hob* for the full dimension (width or depth) of the cooking surface area. Where the cooking *appliance* is fitted with a 'splashback', protection of the rear wall is not required.

3 Additional requirements for Freestanding and Elevated Cooking Appliances – (Measurements D & E)

Where **D**, the distance from the periphery of the nearest *burner* to a horizontal *combustible surface* is less than **200 mm**, then **E** shall be **10 mm** or more, or the horizontal surface shall be above the *trivet*. See insets above.

NOTES

- 1 Requirement 3 does not apply to a freestanding or elevated cooking appliance which is designed to prevent flames or the cooking vessels from extending beyond the periphery of the appliance.
- 2 The 'cooking surface area' is defined as that part of the appliance where cooking normally takes place and does not include those parts of the appliance containing control knobs.
- 3 For definition of hob, see Clause 1.4.64.
- 4 For definition of trivet, see Clause 1.4.109.
- 5 Consideration is to be given to window treatments when located near cooking appliances. See Clause 5.3.4.

3.2 Room ventilation



Caution – This hob may only be installed and operated in rooms permanently ventilated in accordance with current regulations. For proper operation of a gas appliance it is essential for the air necessary for combustion of the gas to be able to flow naturally into the room. Air must flow directly into the room through openings in its outside walls. This (these) opening (s) must have a free passage cross-section of at least 100 cm², or 200 cm² for appliances not equipped with gas safety device. These openings must be constructed so that they cannot be obstructed indoors or outdoors, and should preferably be close to the floor on the side opposite to the combustion gas discharge point. If it is not possible to make the openings in the room where the cooker is installed, the necessary air may be taken from an adjoining room, provided it is not a bedroom or a room with fire risk.

3.3 Discharge of combustion products



Discharge of combustion products must be guaranteed by means of hoods connected to a natural draught flue with certain efficiency, or by means of forced aspiration.

An efficient aspiration system requires careful planning by a specialist capable of installing it, respecting the positions and distances prescribed by standards. After installation, the installer must issue a certificate of conformity.



Instructions for the Installer

4. GAS CONNECTION

This appliance is suitable for installation with Natural Gas or LPG (propane). Refer to page 12 for the relevant burner pressure and appropriate injector sizes. When the appliance is to be connected to Natural Gas then the pressure regulator supplied must be fitted to the gas inlet. A test point (for checking the gas pressure) is supplied either with the regulator or as a separate fitting in the case of LPG (propane) appliances. Connection of the appliance to the gas supply must be in accordance with the requirements of AS5601. A 1/2" BSP connector at the inlet is recommended and the gas supply line to the appliance must be of adequate length to allow sufficient withdrawal of appliance for service or disconnection and be:

1. annealed copper pipe or;
2. flexible hose according to AS/NZ1869 & be at least Class "B", 10 mm diameter.

The appliance must be installed with provision to allow the gas to be turned off and disconnected for servicing and removal of the appliance as required from the gas supply.

Before the appliance is operated make certain all relevant parts are placed in the correct position.

When the installation is completed the installation connections of appliance will require to be leak tested, the burner operating pressure and flame checked and adjusted.

Warranty service calls do not cover these adjustments!

To check the operating pressure of the appliance it is recommended at least 2 large size burners are used. Ensure appliance is secured to wall when installation is completed.

N.G. The regulator supplied must be fitted to the 1/2 BSP thread at the rear of the appliance. An approved manual shut-off valve must be installed. The N.G. regulator must be checked and adjusted to 1.0kPa after installation.

L.P.G. Can be connected to the inlet fitting directly. The pressure must be checked to ensure it is operating at 2.75kPa. A separate test point fitting must be installed between the piping & the appliance for the pressure to be checked to ensure it is operating at 2.75kPa.

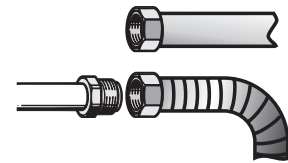
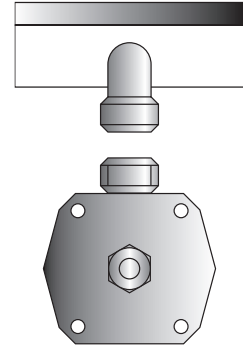

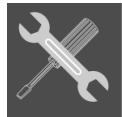

5. Adapting to different types of gas



Before carrying out the operations described below, disconnect the appliance from the electricity supply.

The hob of the cooker is adjusted for use with either **natural gas** at a pressure of **1.0 kPa**. If used with other types of gas, you have to replace the nozzles, then adjust the minimum flame on the gas taps. For nozzle replacement and burner adjustment operate as described in the following paragraph.

5.1 Removing the hob skin

Remove all the burner components in the numerical order shown below:

- Remove the pan stands (Fig.1) by lifting them at the back (1) and extracting them (2). (On 70 cm hobs remove the central pan stand first; on 60 cm hobs the right-hand pan stand must be removed first);
- remove all the knobs (3, Fig.2) by pulling them outward;
- lift all the burner components off the hob (4-5, Fig. 2);
- use the spanner **6** (Fig. 3) to open the bayonet fastenings of the burner fixing rings, applying leverage on the guides **7**;
- after removing all the components described above, lift the front of the hob skin (8, Fig. 4).
- the burners and gas taps can only be accessed by pushing the rear of the hob gently upwards with the aid of a tool (9-10, Fig. 5).

This is necessary to release the internal snap fixing devices. The hob skin can now be removed. Some models may have 2 additional pins at the side (Fig. 5), which must be removed in the same way, using a tool to apply leverage to the hob.

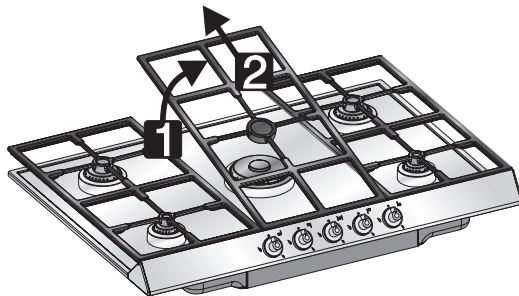

Fig 1)

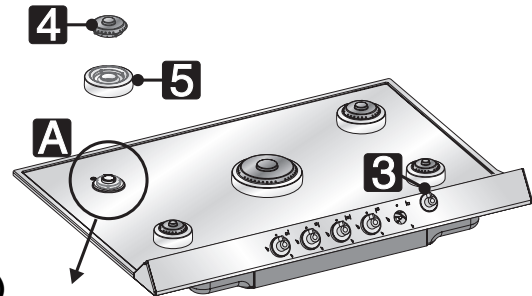

Fig 2)

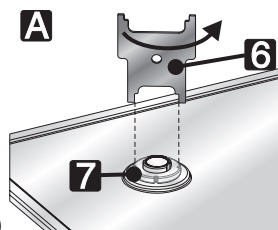

Fig 3)

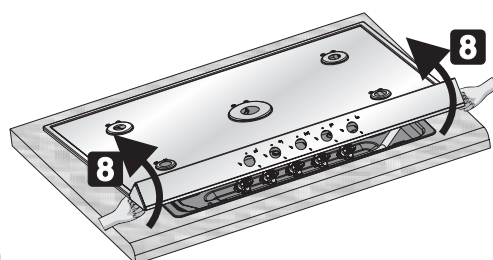

Fig 4)

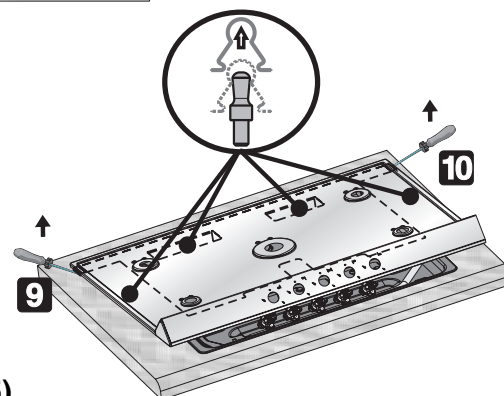
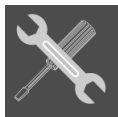

Fig 5)



Instructions for the Installer

5.2 Adjusting for bottled gas

Undo the screw **A** and push the support **B** fully down. Remove the nozzle **C** with a spanner and fit the suitable one following the instructions in the tables referring to the type of gas to be used. The nozzle must not be tightened with a torque of more than **3 Nm**. Return the support **B** to its original position, so that the nozzle **C** is perfectly covered. Regulate the air flow by moving the Venturi pipe **D** until the distance “**X**” stated in point “5.4 Adjusting the primary air flow” is obtained and secure it with the screw **A**. When the adjustments are complete, restore the seals with wax or an equivalent material.

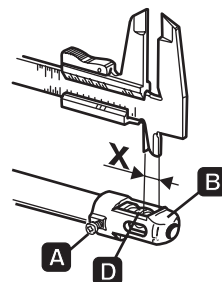
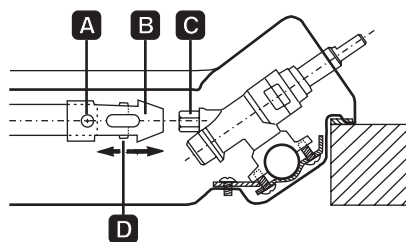

Burner		ULPG – 2.75 kPa	
		Nominal gas Consumption (MJ/h)	Injector (mm)
Auxiliary		4.1	0.54
Semi rapid		6.0	0.68
Rapid (3)		12.6	0.95
Rapid (6)		11.2	0.85
Rapid (7)		11.2	0.85
WOK double flame (8)	Internal	3.6	0.50
	External	15.1	1.05
WOK double flame (4)	Internal	3.6	0.50
	External	14.4	0.98
WOK		15.1	1.05

5.3 Adjusting for natural gas

The appliance is tested with **natural gas** at the pressure of 1.0 kPa. To return the appliance to the condition required to use this type of gas, proceed as described in point “5.2 Adjusting for bottled gas” but select the nozzles and adjust the primary air flow for natural gas, as indicated in the table below and in point “5.4 Adjusting the primary air flow”.

Burner		Natural gas – 1.0 kPa	
		Nominal gas Consumption (MJ/h)	Injector (mm)
Auxiliary		4.5	0.98
Semi rapid		6.1	1.10
Rapid (3)		12.6	1.60
Rapid (6)		11.9	1.55
Rapid (7)		10.8	1.45
WOK double flame (8)	Internal	3.6	0.85
	External	15.1	1.70
WOK double flame (4)	Internal	3.6	0.85
	External	14	1.65
WOK		15.1	1.70

Instructions for the Installer

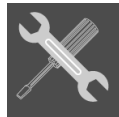

5.4 Adjusting the primary air flow

Refers to the gap "X" in mm.

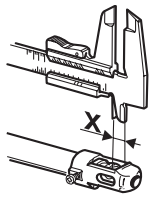

BURNER		NG – 1.0 kPa	ULPG – 2.75kPa
Auxiliary		4.0	10.0
Semi rapid		4.0	10.0
Rapid (3)		4.0	10.0
Rapid (6)		4.0	10.0
Rapid (7)		4.0	10.0
WOK double flame (4-8)	Internal	5.0	8.0
	External	10.0	13.0
WOK		5.0	12.0

5.5 Reassembling the hob skin

Reverse the procedure described in point "5.1 Removing the hob skin".



When replacing the burner rings, bear in mind that they must be **fully** tightened using the spanner provided.

Put the pan stands back in place, fitting first those at the side and then the central one.

5.6 Adjusting the minimum setting for natural gas and town gas

Reassemble the components on the burner and fit the knobs onto the tap rods.

Light the burner and turn it to the minimum setting. Remove the knob again and adjust the regulator screw inside or beside the tap rod (depending on the model) until an even minimum flame is obtained. Put the knob back in place and check the stability of the burner flame (the flame must not go out when the knob is turned quickly from the maximum to the minimum setting).

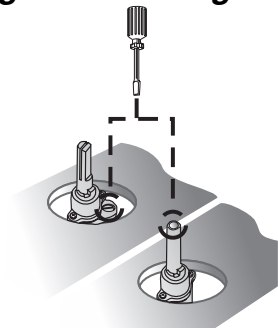

5.7 Adjusting the minimum for bottled gas

To adjust the minimum level when using bottled gas, the adjuster screw inside or beside the tap rod must be turned fully clockwise (depending on the models). The diameters of the bypasses for each individual burner are stated in point "5.2 Adjusting for bottled gas".



After adjusting for use of a gas other than the gas used for testing the appliance, replace the label on the casing with the label for the new gas. The label is available from your nearest Authorised Service Centre.



Instructions for the Installer

5.8 Hob burner layout

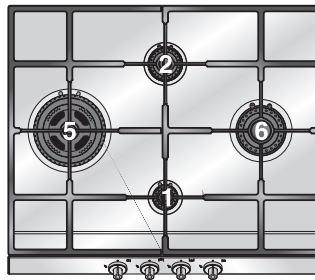
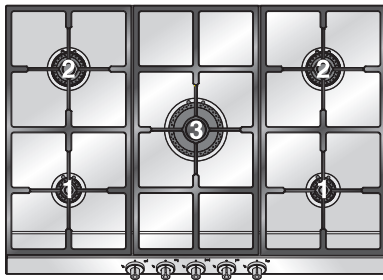

Burner type

- 1 Auxiliary
- 2 Semi rapid
- 3 Rapid
- 4 WOK Double flame
- 5 WOK
- 6 Rapid
- 7 Rapid
- 8 WOK Double flame

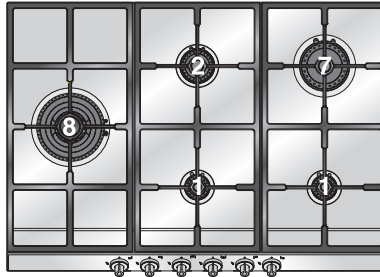
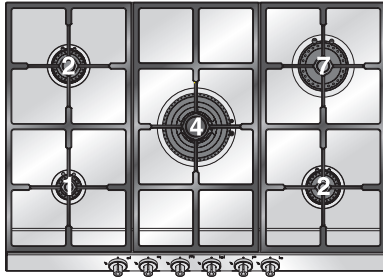

5.9 Greasing the gas taps

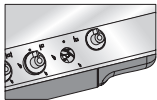

Over time, the gas taps may become stiff or jam. Clean their insides and change their lubricating grease. **This operation must be carried out by a skilled technician.**



6. Description of controls

6.1 The front panel

All the hob's control and monitoring devices are placed together on the front panel.

MODEL 60 CONTROL PANEL

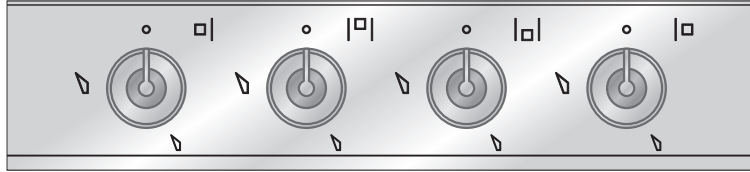

4 Burner Hob

MODEL 70 CONTROL PANEL

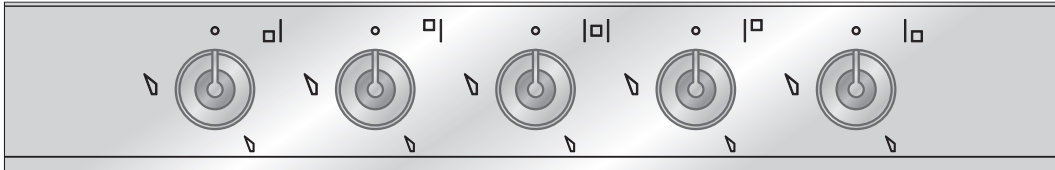

5 Burner Hob

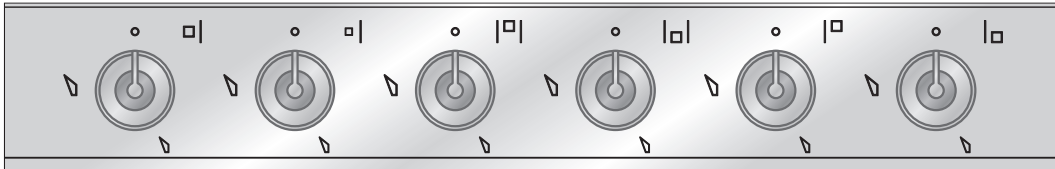

6 Burner Hob, UR2 at Side

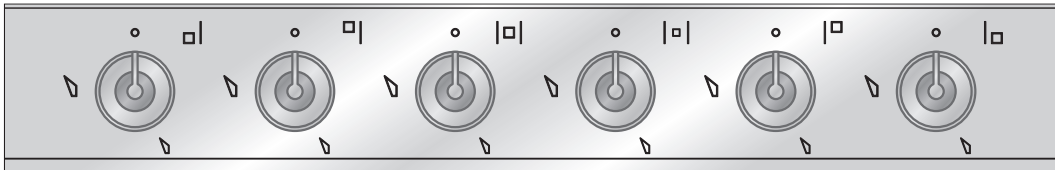

6 Burner Hob, central UR2

KNOB OPERATING MODE

To light the flame, press the knob and at the same time turn it anti-clockwise to the minimum flame symbol.

To adjust the flame, turn the knob to the zone between the maximum and the minimum settings.

To turn off the burner, turn the knob back to the O position.

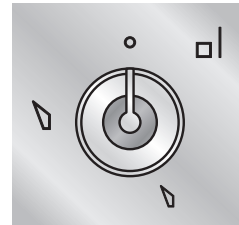

BURNER LAYOUT - Key to symbols

	Front left-hand burner		Front central burner		Front right-hand burner
	Left-hand central burner / Outside left-hand central burner		Central burner / Outside central burner		Right-hand central burner
	Inside left-hand central burner		Inside central burner		Rear right-hand burner
	Rear left-hand burner		Rear central burner		



Instructions for the User

7. Using the hob



Check that the fixing rings, burners, flame diffuser rings and pan stands are fitted correctly.

The burner pins **A** must be fitted into the recesses **B** in the flame diffuser ring. The holes **C** in the flame diffuser ring must mate with the ignition plugs and thermocouples **D** on the hob.

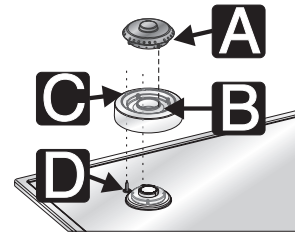

7.1 Lighting burners with safety device



The burner it controls is shown next to each knob (the example here shows the front left-hand burner).

The appliance is equipped with electronic ignition. Simply press the knob and turn it anti-clockwise to the minimum flame symbol , until the burner lights. Keep the knob pressed down for about 2 seconds to keep the flame alight and prime the safety device. The burner may go out when the knob is released. In this case, repeat the operation, keeping the knob pressed down for longer.



If the burners should go out accidentally the safety device will be tripped about 20 seconds later, cutting off the gas supply even if the gas tap is open.

7.2 Positioning the griddle plate

A special griddle plate for use with the hob is available from authorised dealers. This plate must be placed on the pan stands properly CENTRED; it must never be fitted instead of a pan stand.

Ensure that the griddle plate is properly centred on the pan stand; if it is not correctly positioned, the knobs may overheat while it is in use.

7.3 Practical hints for using the burners

For better burner efficiency and to minimise gas consumption, use flat, even - bottomed pans with lids of suitable size for the burner (see point "7.4 Pan Diameters").

When cooking, to prevent burns or damage to the hob all pans or griddle plates must be placed inside the perimeter of the hob and must be at least **3-4 cm** from the knobs.





7.4 Pan diameters

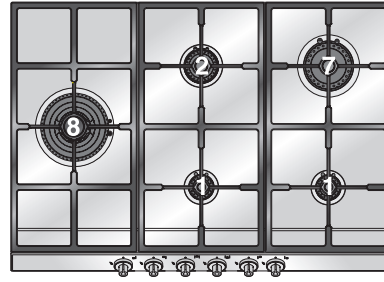
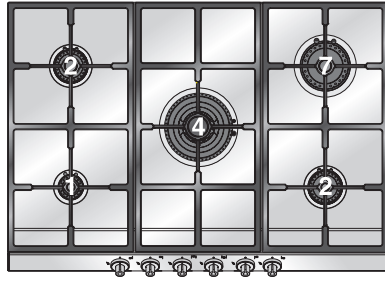
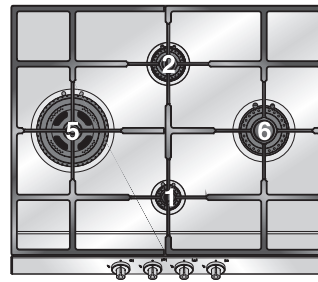
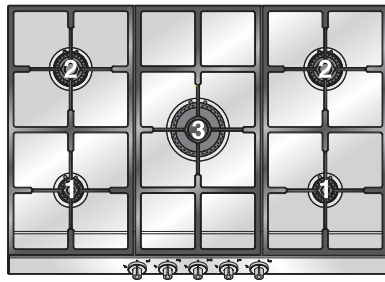
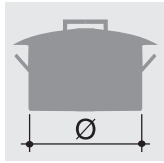

BURNERS

min. and max. Ø (in cm)

1. Auxiliary	7-18
2. Semi rapid	10-24
3. Rapid	18-24
4. WOK double flame	20-28
5. WOK	20-28
6. Rapid	18-24
7. Rapid	18-24
8. WOK double flame	20-28



Instructions for the User

8. Cleaning and maintenance



Before carrying out any operations, disconnect the appliance from the electricity supply.

8.1 Cleaning stainless steel



To keep the hob in good condition, it must be cleaned regularly, after each use, first allowing it to cool.

8.1.1 Routine daily hob cleaning

When cleaning and caring for stainless steel surfaces, always use **only** specific products which do not contain abrasives or chlorine-based acids.

Instructions for use: pour the product onto a damp cloth and wipe over the surface, then rinse thoroughly and dry with a soft cloth or chamois leather.

8.1.2 Food stains or spills

Never use metal scouring pads or sharp scrapers which will damage the surface.

Use ordinary non-abrasive products for steel, with the aid of non-scratching sponges and wooden or plastic utensils if necessary.

Rinse thoroughly and dry with a soft cloth or chamois leather.



8.2 Cleaning the components



8.2.1 The knobs

The knobs and front panel must be cleaned with a soft cloth dipped in warm water and dried thoroughly. The knobs can easily be removed by pulling them outwards.



Never clean the knobs or front panel with aggressive products containing alcohol or steel or glass cleaners, since they might cause permanent damage.

8.2.2 Pan stands and burners



Remove the pan stands and wash them in warm water with a non-abrasive detergent, taking care to remove all deposits. Put them back on the hob.

These components must never be washed in a dishwasher.

8.2.3 The flame diffuser rings

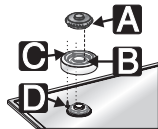

The burner caps and flame diffuser rings can be removed for easier cleaning; wash them in hot water and non-abrasive detergent, taking care to remove all deposits, and wait for them to **dry completely**.

The burner pins **A** must be fitted into the recesses **B** in the flame diffuser ring. The holes **C** in the flame diffuser ring must mate with the ignition plugs and thermocouples **D** on the hob.

NEVER REMOVE THE FIXING RINGS TO CLEAN THE HOB.

8.2.4 The plugs and thermocouples

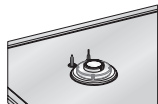

For best performance, the ignition plugs and thermocouples must always be kept thoroughly clean. Check them frequently and if necessary clean them with a wet cloth. Remove any dry residues with a wooden toothpick or a needle.



914773334/ B