

Table of Contents

GB-IE

1.	PRECAUTIONS FOR SAFETY AND USE _____	44
2.	INSTALLING THE APPLIANCE _____	46
3.	ADAPTATION TO DIFFERENT TYPES OF GAS _____	49
4.	FINAL OPERATIONS _____	51
5.	DESCRIPTION OF CONTROLS _____	52
6.	USING THE HOB _____	59
7.	USING THE OVENS _____	61
8.	USING THE "PIZZA" FUNCTION _____	62
9.	ACCESSORIES AVAILABLE _____	64
10.	COOKING ADVICE _____	66
11.	CLEANING AND MAINTENANCE _____	72
12.	EXTRAORDINARY MAINTENANCE _____	78

THESE INSTRUCTIONS ONLY APPLY TO THE COUNTRIES OF DESTINATION WHOSE IDENTIFICATION SYMBOLS ARE LISTED ON THE COVER OF THIS MANUAL.



*INSTRUCTIONS FOR THE INSTALLER: these are intended for the **qualified engineer** who is to check the gas supply system and install, commission and test the appliance.*



INSTRUCTIONS FOR THE USER: these provide recommendations for use, a description of the controls and the correct procedures for cleaning and maintaining the appliance.

1. PRECAUTIONS FOR SAFETY AND USE



THIS MANUAL IS AN INTEGRAL PART OF THE APPLIANCE. TAKE GOOD CARE OF IT AND KEEP IT TO HAND THROUGHOUT THE COOKER'S LIFE CYCLE. USERS ARE ADVISED TO READ THIS MANUAL AND ALL THE INSTRUCTIONS IT CONTAINS BEFORE USING THE COOKER. ALSO KEEP THE SET OF NOZZLES PROVIDED IN A SAFE PLACE. INSTALLATION MUST BE CARRIED OUT BY QUALIFIED STAFF IN COMPLIANCE WITH THE RELEVANT REGULATIONS. THIS APPLIANCE IS INTENDED FOR HOUSEHOLD USE AND COMPLIES WITH THE **EEC DIRECTIVES** CURRENTLY IN FORCE. THE APPLIANCE IS BUILT TO PROVIDE THE FOLLOWING FUNCTION: **COOKING AND HEATING FOODS**; ALL OTHER USES ARE TO BE CONSIDERED IMPROPER.

THE MANUFACTURER DECLINES ALL LIABILITY FOR USES OTHER THAN THOSE STATED ABOVE.



NEVER LEAVE PACKAGING RESIDUES UNATTENDED IN THE HOME. SEPARATE WASTE PACKAGING MATERIALS BY TYPE AND CONSIGN THEM TO THE NEAREST SEPARATE DISPOSAL CENTRE.



THE APPLIANCE MUST BE CONNECTED TO EARTH IN COMPLIANCE WITH ELECTRICAL SYSTEM SAFETY REGULATIONS.



THE PLUG TO BE CONNECTED TO THE POWER SUPPLY LEAD AND THE RELATIVE SOCKET MUST BE OF THE SAME TYPE AND COMPLY WITH THE RELEVANT REGULATIONS.

THE POWER SUPPLY SOCKET MUST BE ACCESSIBLE EVEN AFTER THE APPLIANCE HAS BEEN BUILT-IN.

NEVER DISCONNECT THE PLUG BY PULLING ON THE POWER SUPPLY LEAD.



IMMEDIATELY AFTER INSTALLATION, CARRY OUT A QUICK TEST ON THE APPLIANCE FOLLOWING THE INSTRUCTIONS PROVIDED LATER IN THIS MANUAL. IF THE APPLIANCE FAILS TO OPERATE, DISCONNECT IT FROM THE ELECTRICAL MAINS AND CONTACT YOUR NEAREST SERVICE CENTRE.

NEVER ATTEMPT TO REPAIR THE APPLIANCE YOURSELF.



AFTER EACH USE OF THE APPLIANCE, ALWAYS CHECK THAT THE CONTROL KNOBS ARE TURNED TO  (OFF).



NEVER PLACE FLAMMABLE OBJECTS IN THE OVENS: IF THEY SHOULD ACCIDENTALLY BE SWITCHED ON, THIS MIGHT CAUSE A FIRE.



THE NAMEPLATE WITH THE TECHNICAL DATA, SERIAL NUMBER AND MARK IS IN A VISIBLE POSITION IN THE STORAGE COMPARTMENT.
THE NAMEPLATE MUST NEVER BE REMOVED.



NEVER PLACE PANS WITH BOTTOMS WHICH ARE NOT PERFECTLY FLAT AND SMOOTH ON THE HOB PAN STANDS.



THE APPLIANCE BECOMES VERY HOT DURING USE. TAKE CARE NOT TO TOUCH THE HEATING ELEMENTS INSIDE THE OVEN.



THIS APPLIANCE MUST NEVER BE INSTALLED ON A STAND.



INSTALL THE APPLIANCE SO THAT WHEN DRAWERS OR DOORS OF UNITS INSTALLED AT HOB HEIGHT ARE OPENED, ACCIDENTAL CONTACT WITH PANS ON THE HOB IS NOT POSSIBLE.



NEVER USE PANS OR GRIDDLE PLATES WHICH PROJECT BEYOND THE OUTSIDE EDGE OF THE HOB.



THE APPLIANCE IS INTENDED FOR USE BY ADULTS. KEEP CHILDREN AT A SAFE DISTANCE AND NEVER ALLOW THEM TO PLAY WITH IT.



THIS APPLIANCE IS TAGGED UNDER EUROPEAN DIRECTIVE 2002/96/EC ON WASTE ELECTRICAL AND ELECTRONIC EQUIPMENT (WEEE). THIS DIRECTIVE CONTAINS THE REGULATIONS GOVERNING THE COLLECTION AND RECYCLING OF DECOMMISSIONED APPLIANCES THROUGHOUT THE EUROPEAN UNION.



BEFORE THE APPLIANCE IS PUT INTO OPERATION, ALL THE LABELS AND PROTECTIVE FILMS APPLIED INSIDE OR OUTSIDE MUST BE REMOVED.



The manufacturer declines all responsibility for injury or damage caused by failure to comply with the above regulations or deriving from tampering with even just one part of the appliance and the use of non-original spare parts.



2. INSTALLING THE APPLIANCE



Installation must be carried out by a **qualified engineer** in compliance with the relevant regulations.

It may be installed against walls one of which is higher than the worktop surface, at least 50 mm from the side of the appliance, as shown in the installation class drawings A and B. Wall units or extractor hoods installed above the appliance's work-top must be at least 750 mm above it.

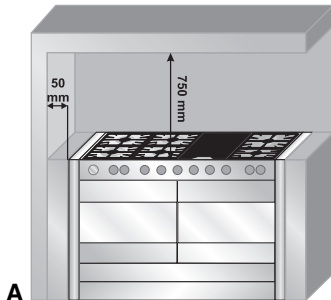

A

Built-in Appliance

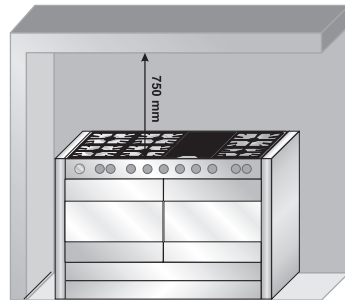

B

Free-Standing Installation

2.1 Positioning and levelling the appliance



The appliance is equipped with wheels and adjustable feet to simplify the positioning procedure. To use the front wheels, screw in the foot as shown here, so that the appliance rests on the front wheels. However, to allow the appliance to be moved freely it must be lifted at the back. To do this, proceed as follows:

use a 10 socket wrench to screw in the 2 hex nuts underneath the oven compartment: this raises the appliance either to level it or to allow it to be moved around.

Once all procedures are complete, retighten the front feet and the hex nuts to set the cooker stable and level.

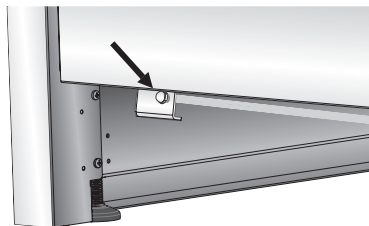



Instructions for the Installer

GB-IE

2.2 Electrical connection



Check that the voltage and size of the power supply line are as specified on the nameplate inside the storage compartment.

This nameplate must never be removed.



The plug on the end of the power supply cable and the wall socket must be of the same type (in compliance with the relevant national standards). Check that the power supply line is properly earthed. The use of reductions, adapters or junctions is not recommended.



The appliance's power supply line must be fitted with an omnipolar breaking device with contact gap of at least **3 mm**, located in an easily accessible position close to the appliance itself.

The appliance has a terminal board on its rear.

To access it, remove the back cover.

Make the electrical connection in accordance with the wiring diagram shown below.

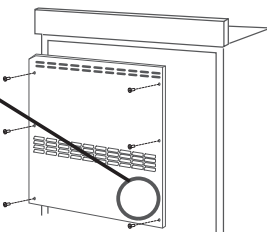

Operation at 380-415V3N~: use a H05RR-F or H05RN-F five-wire cable (cable of 5 x 1.5 mm²).

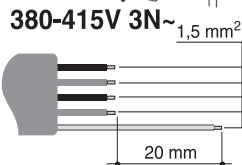

Operation at 380-415V2N~: use a H05RR-F or H05RNF four-wire cable (cable of 4 x 2.5 mm²).

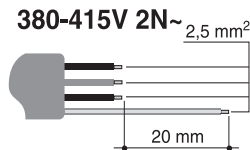

Operation at 220-240 V~: use a H05RR-F / H05RNF three-wire cable (cable of 3 x 6 mm²).

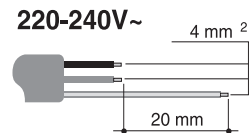

The earth wire (yellow-green) must be at least 20 mm longer than the other wires at the end for connection to the appliance.



The manufacturer declines all responsibility for injury or damage caused by failure to comply with the above regulations or deriving from tampering with even just one part of the appliance.



2.3 Ventilation requirements

The room containing the appliance should have an air supply in accordance with B.S. 5440 part 2 1989.

1. All rooms require an opening window or equivalent, and some rooms will require a permanent vent as well.
2. For room volumes up to 5 m³ an air vent of 100 cm² is required.
3. If the room has a door that opens directly to the outside, and the room exceeds 1 m³ no air vent is required.
4. For room volumes between 5 m³ and 10 m³ an air vent of 50 cm² is required.
5. If there are other fuel burning appliances in the same room B.S. 5440 part 2 1989 should be consulted to determine the air vent requirements.
6. This appliance must not be installed in a bed sitting room of less than 20 m³ or in a bathroom or shower room.

Windows and permanent vents should therefore not be blocked or removed without first consulting a Corgi gas installer.

Failure to install appliances correctly is dangerous and could lead to prosecution.

2.4 Connecting to natural and LPG gas (Please see connection diagram)

Make the connection to the appliance using flexible bayonet style hose in accordance to B.S. 669. The hose connection at the rear of the appliance has a 1/2" BSP internal thread. Please use seal **C** between the flexible connection **L** and the appliance supply tube **B**. When making the connection, make sure that no stress of any kind is applied to the cooker and that the hose does not touch any sharp edges.

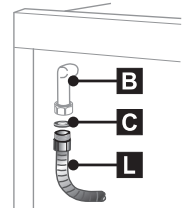

If connecting to LPG the bayonet hose must have red bands on it.

2.5 Instruction for wall fixing (only on some models)

- 1) Fix the screw to the wall and hook the chain (**B**);
- 2) Hook the chain to the hole positioned at the rear of the cooker by the gas pipe (**A**);
- 3) Once the chain is in position, push the cooker against the wall;
- 4) The height of the screw hole from floor level must not exceed 800 mm (**C**).

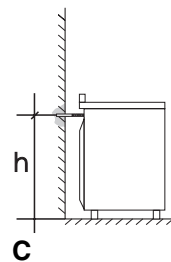
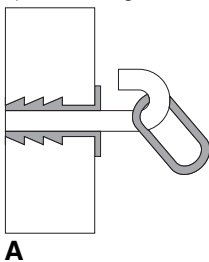



3. ADAPTATION TO DIFFERENT TYPES OF GAS



Before performing any cleaning or maintenance work, switch off the power supply to the appliance.

The cooking hob of the cooker is preset for **G20 natural gas** at a pressure of 20 mbar. In the case of functioning with other types of gas the burner nozzles must be changed and the minimum flame adjusted on the gas taps. Replace the burner nozzles as indicated in the table of the gas to be used.

3.1 Changing nozzles

1. Extract the grids and remove all the caps and flame-spreader crowns;
2. unscrew the burner nozzles with a 7 mm socket wrench;
3. proceed with replacing the burner nozzles in accordance with the table for the gas in question.

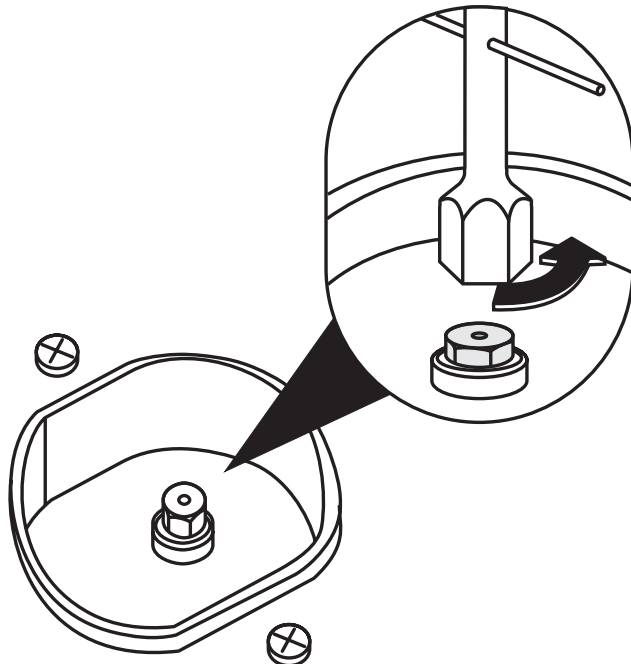



3.2 Burner and nozzle characteristics table

Burner	Rated heating capacity (kW)	LPG – G30/G31 28/37 mbar (drawing ref. X238)				
		Nozzle diameter 1/100 mm	By-pass Mm 1/100	Reduced flowrate (W)	Flowrate g/h G30	Flowrate g/h G31
Auxiliary	1.05	50	30	400	76	75
Semi rapid	1.8	65	33	500	131	129
Rapid	3.0	85	45	800	218	215
Fish Burner	1.9	68	45	800	138	136
Ultra rapid	4.0	100	65	1600	291	286

Burner	Rated heating capacity (kW)	NATURAL GAS – G20 20 mbar		
		Nozzle diameter 1/100 mm	Drawing Ref.	Reduced flowrate (W)
Auxiliary	1.05	72	(X)	400
Semi rapid	1.8	97	(Z)	500
Rapid	3.0	115	(Y)	800
Fish Burner	1.9	94	(X)	800
Ultra rapid	4.0	135	(K)	1600

3.3 Hob burner layout

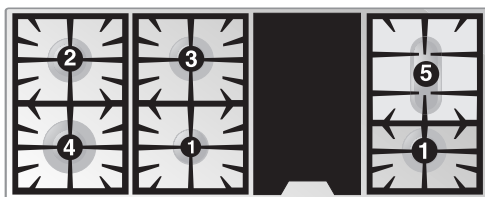

BURNERS

- 1 Auxiliary
- 2 Semi rapid
- 3 Rapid
- 4 Ultra rapid
- 5 Fish



4. FINAL OPERATIONS

After changing the nozzles, put the pan stands, the burner caps and flame diffuser rings back in place.



After adjusting for use of a gas other than the gas used for testing the appliance, replace the gas setting label on the appliance with the label for the new gas. The label is supplied in the bag with the nozzles.

4.1 Adjusting the minimum setting for town gas and natural gas

Light the burner and turn it to the minimum setting Δ . Remove the gas tap knob and adjust the regulator screw inside or beside the tap rod (depending on the model) until an even minimum flame is obtained. Put the knob back in place and check the stability of the burner flame (the flame must not go out when the knob is turned quickly from the maximum to the minimum setting). Repeat the operation on all the gas taps.

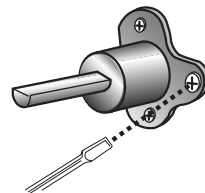

4.2 Adjusting the minimum for bottled gas

To adjust the minimum level when using bottled gas, the adjuster screw inside or beside the tap rod must be turned fully clockwise (depending on the models).

The diameters of the bypasses for each individual burner are stated in point "3.2 Burner and Nozzle Data Tables".

4.3 Fitting the rear splash-back

- Place the splash-back on the hob, aligning the holes **A** with the holes **B**.
- Fix the splash-back to the hob by tightening the screws **C**.

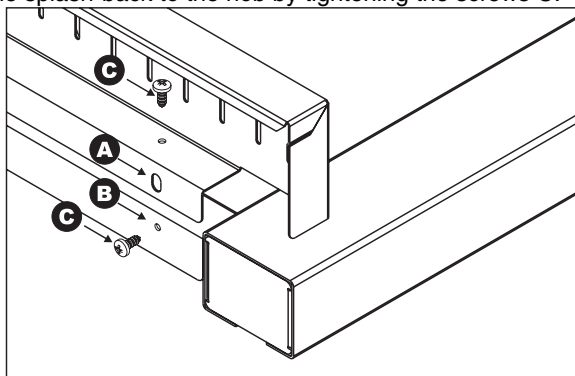





5. DESCRIPTION OF CONTROLS



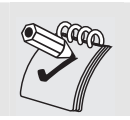
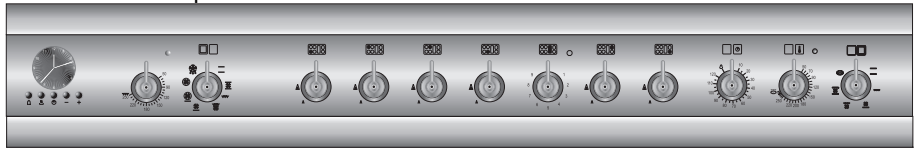









5.1 The front panel

All the cooker's control and monitoring devices are placed together on the front panel.



At first use after a power blackout, press the middle knob  for 1 / 2 seconds to enable oven cooking operations.

KEY TO SYMBOLS

	FRONT LEFT-HAND BURNER		REAR LEFT-HAND BURNER
	FRONT CENTRAL BURNER		REAR CENTRAL BURNER
	FRONT RIGHT-HAND BURNER		REAR RIGHT-HAND BURNER
	BARBECUE ELEMENT		RIGHT-HAND OVEN TIMER
	LEFT-HAND OVEN THERMOSTAT		RIGHT-HAND OVEN THERMOSTAT
	LEFT-HAND OVEN FUNCTIONS		RIGHT-HAND OVEN FUNCTIONS

LEFT-HAND OVEN THERMOSTAT KNOB

The cooking temperature is selected by turning the knob clockwise to the required setting, between 50° and 250°C. The light comes on to indicate that the oven is heating up. This light goes out when the set temperature is reached. When it flashes at regular intervals, the temperature inside the oven is being kept constantly at the set level.





Instructions for the User

GB-IE

LEFT-HAND OVEN FUNCTION SELECTOR KNOB

Turn the knob to select one of the following functions:

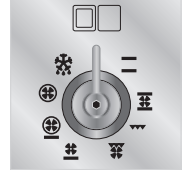

NO FUNCTION SET



TOP AND BOTTOM HEATING ELEMENTS



TOP AND BOTTOM HEATING ELEMENTS + FAN



GRILL ELEMENT



GRILL ELEMENT + FAN



BOTTOM HEATING ELEMENT + FAN



BOTTOM HEATING ELEMENT + FAN HEATING ELEMENT







FAN HEATING ELEMENT + FAN



DEFROSTING

HOB BURNER CONTROL KNOB

To light the flame, press the knob and turn it anti-clockwise to the maximum flame symbol . To adjust the flame, turn the knob to the zone between the maximum  and the minimum  settings. To turn off the burner, turn the knob to the  position.

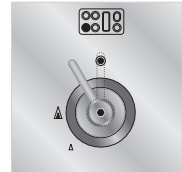

BARBECUE ELEMENT POWER REGULATOR KNOB

This knob is used to set the power of the barbecue griddle on the hob. Turn the knob to any setting between "1" and "9" to switch on the heating element. The light comes on to indicate that the element is heating up.

To switch off the element, return the knob back to the "0" setting.



WARNING: after it has been in operation for some time, the griddle remains hot even after the heating element has been switched off: keep children at a safe distance.

Instructions for the User



RIGHT-HAND OVEN THERMOSTAT KNOB

The cooking temperature is set by turning the knob clockwise to the value required, between 50° and 280° (🍷)C.

The light comes on to indicate that the oven is heating up. This light goes out when the set temperature is reached. When it flashes at regular intervals, the temperature inside the oven is being kept constantly at the set level.

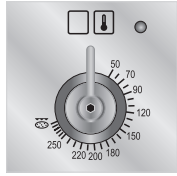

RIGHT-HAND OVEN FUNCTION SELECTOR KNOB

Turn the knob to select one of the following functions:

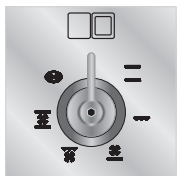

NO FUNCTION SET



TOP AND BOTTOM HEATING ELEMENTS



GRILL ELEMENT



BOTTOM HEATING ELEMENT + FAN



GRILL ELEMENT + FAN



TOP AND BOTTOM HEATING ELEMENTS + FAN



PIZZA FUNCTION

RIGHT OVEN TIMER KNOB

Allows to select manual cooking or the minute minder; the oven switches off automatically at the end of cooking.

If no selection of a cooking duration is made, the timer knob must be positioned on the symbol 🕒

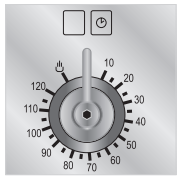







Instructions for the User

GB-IE



5.2 Electronic Analogue Clock



LIST OF FUNCTIONS

-  MINUTE-MINDER BUTTON
-  END OF COOKING BUTTON
-  CLOCK ADJUSTMENT AND RESET
-  VALUE DECREASE BUTTON
-  VALUE INCREASE BUTTON

5.2.1 Setting the time





When the oven is used for the first time, or after an interruption in the electricity supply, the display flashes at regular intervals. Press the  key for 1 / 2 seconds to stop the display flashing and start the procedure for setting the current time. Press the value modification keys  or  to increase or decrease the setting by one minute for each pressure. Press one of the two value modification keys until the current time appears. 6/7 seconds after the last key is pressed, the clock will start from the time set.



At the end of each programmed operation 8 beeps will sound 3/4 times at intervals of about 1 and a half minutes. This sequence can be stopped at any time by pressing any key.



5.2.2 Minute-Minder

- This function does not stop cooking; it simply activates the buzzer. Press the  key and the display will light up as shown in figure 1;
- Within 6/7 seconds, press the  or  keys to set the minute-minder. Each time a key is pressed, 1 outside segment, representing 1 minute of cooking time, will light up or go out. (figure 2 shows a cooking time of 10 minutes).
- 6/7 seconds after the last key is pressed, the countdown will start; when it finishes, the buzzer will sound.
- During the countdown, the current time can be viewed by pressing the  key once; press it again to return to the minute minder display.
- **At the end of the countdown, the oven must be switched off manually by turning the thermostat and function selector knob to 0.**

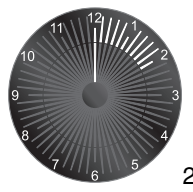
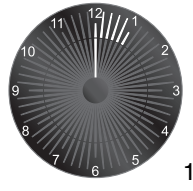











Instructions for the User

GB-IE

5.2.3 Programming

Cooking duration: the 2nd button  can be pressed to set the cooking duration. Before it can be set, the thermostat must be turned to the cooking temperature required and the function selector knob to any setting. To set the cooking duration, proceed as follows:

- Press the  key for 1 / 2 seconds; the pointer will locate on 12 (Fig. 1).
- Use the  and  keys to set the cooking duration: each pressure on the  key adds 1 minute to the cooking duration, and every 12 minutes a new inside segment will light up (figure 2 shows a cooking duration of 1 hour).
- Once the duration required is obtained, cooking will start about 6 seconds after the last pressure on  or .
- Once cooking has started the display will show the current time, represented by the constantly illuminated segments, and the minutes left to the end of the cooking time, represented by the flashing segments (each flashing segment means 12 minutes of cooking time left).
- At the end of the cooking time the timer will switch the oven heating elements off, the beeps will start to sound and the numbers on the dial will flash.
- The duration can also be reset by resetting the program selected: pressing the central key  for 1 or 2 seconds will delete the duration set and the oven will have to be switched off in manual mode.



Caution: it is not possible to set cooking durations of more than 6 hours.

Instructions for the User



Starting cooking: as well as setting a cooking duration, the cooking start time can also be set (with a maximum delay of 12 hours from the current time). To set the cooking start/end time, proceed as follows:

- Set the cooking duration as described in the previous point.
- Within 6/7 seconds of the last pressure on the **-** or **+** keys, press the **|||** key again to set the cooking start time. The current time will appear on the display with internal segments illuminated to show the end of cooking time. Use the **-** and **+** keys to set the cooking start time.
- 6/7 seconds after the last key is pressed, the display will show the current time and the cooking start and end times, which will be represented by the illuminated inside segments. The display segments will be constantly illuminated as long as the current time is not the same as the cooking start time; as soon as the current time reaches the set starting time, all the inside segments will start to flash, indicating that the oven has started cooking.
- At the end of the cooking time the timer will switch the oven heating elements off, the beeps will start to sound and the numbers on the dial will flash.
- To reset the whole program set, keep the central key  pressed for 1 or 2 seconds: if cooking has already started, the oven will have to be switched off by hand.
- Here we can see a programming example: the current time is 7:06 and cooking is programmed to start at 8:00 and end at 9:00.
- At 8 o'clock the inside segments between 8 and 9 will start to flash, while the hours hand will remain still.



Caution: for the oven to start cooking operations after the programming procedures just described, the thermostat and function selector knob must correctly set on the temperature and function required.

5.2.4 "DEMO" Function

Models with analogue/digital programmer feature a "DEMO" function which deactivates the heating elements while leaving the other functions unchanged. To activate it, simply press the **|||**, **-**, and **+** keys for 3/4 seconds. A confirmation beep will inform the user that the function is active. To deactivate it, simply repeat the same procedure.



Instructions for the User

GB-IE

6. USING THE HOB

6.1 Lighting the hob burners



Before lighting the hob burners check that the flame diffuser rings are correctly in place with their respective burner caps, making sure that the holes **A** in the flame diffusers are aligned with the plugs and thermocouples. The special pan stand **B** is for use with woks.

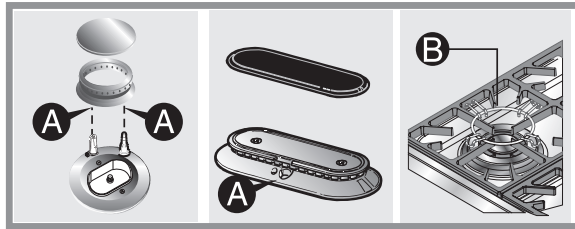

The burner it controls is shown next to each knob. The appliance is equipped with an electronic ignition device. Simply press the knob and turn it anti-clockwise to the maximum flame symbol Δ , until the burner lights. Keep the knob pressed down for about 2 seconds to allow the thermocouple to heat up. The burner may go out when the knob is released: this means that the thermocouple has not warmed up enough. Repeat the operation, keeping the knob pressed down for longer.



If the burners should go out accidentally a safety device will be tripped about 20 seconds later, cutting off the gas supply even if the gas tap is open.



6.2 Practical hints for using the hob burners



For better burner efficiency and to minimise gas consumption, use pans with lids of suitable size for the burner, so that flames do not reach up the sides of the pan (see point "6.3 Pan Diameters"). Once the contents come to the boil, turn down the flame far enough to prevent the liquid from boiling over. When cooking, to prevent burns or damage to the hob all pans or griddle plates must be placed inside the perimeter of the hob. All pans must have smooth, flat bottoms. Take the greatest care when using fats or oils since they may catch fire if overheated. If the flame accidentally goes out, turn off the control knob and wait at least 1 minute before trying to re-light the burner.

6.3 Pan diameters

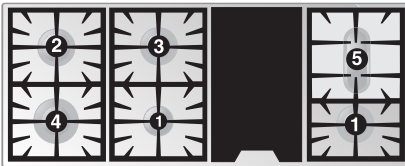

BURNERS		min. and max. Ø (in cm)
1	Auxiliary	12-14
2	Semi rapid	16-24
3	Rapid	18-26
4	Ultra rapid	20-26
5	Fish	Special oval pans

6.4 Using the barbecue griddle



This griddle plate has a non-stick (Teflon) coating. The non-stick film is very delicate and may be damaged if metal utensils are used.

Use only utensils made from wood or plastic resistant to high temperatures.





Instructions for the User

GB-IE

7. USING THE OVENS

7.1 Precautions and General Advice

When the oven is used for the first time, it should be heated to the maximum temperature (250-220°C) for long enough to burn off any oily residues left by the manufacturing process, which might contaminate foods with unpleasant smells.



During cooking, do not cover the bottom of the oven with aluminium or tin foil, and do not place pans or trays on it; this may damage the enamel coating. If you wish to use greaseproof paper, position it so that it does not interfere with the hot air circulation inside the oven.



To avoid unpleasant contact with any steam inside the oven, open the door in two stages: hold it half-open (about 5 cm) for 4-5 seconds, then open it completely. If you have to carry out any procedures on foods, leave the door open for as short a time as possible to prevent a drop in the oven temperature which will impair the cooking results.

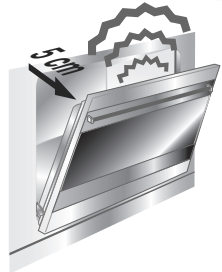

7.2 Oven light

It comes on when the function selector is turned to any setting.

7.3 Cooling fan system

The appliance is equipped with a cooling system, which comes into operation as soon as a cooking function is selected. This is also the case for cooking with the minute minder.

Fans cause a steady outflow of air from the rear top skirtboard on the rear of the cooking hob, which may continue for a brief period of time even after the oven has been turned off.

This ventilation system ensures that the temperatures on the outside of the appliance meet the standards required by the current regulations.

7.4 Storage compartment

The storage compartment is in the bottom of the cooker, underneath the ovens. To open it, pull on the top of the door.

Never use it to store flammable materials such as rags, paper, etc.; it is intended to take the appliance's metal accessories only.

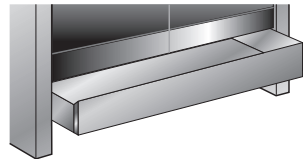

Caution: when the ovens are in use, the bottom inside surface of the storage compartment may become hot.



8. USING THE "PIZZA" FUNCTION

This appliance is equipped with a function specially developed for cooking pizza. This function is identified by the  symbol on the oven functions knob. To cook a pizza, proceed as described below.

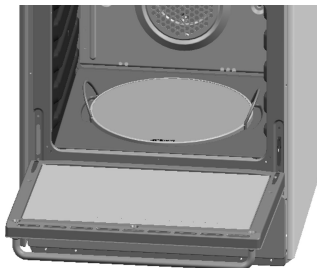

Set the oven functions knob on the  symbol and the thermostat knob on the  symbol.

Preheat with these settings until the thermostat light goes out, then place the pizza on the special plate. It does not normally take more than 3-4 minutes to cook a pizza to perfection, although this time may vary depending on the dough used or individual taste.

8.1.1 Precautions for using the pizza plate

- Never use the pizza plate except as described above (for example, never use it on gas or ceramic hobs, or on ovens not designed to take this accessory).
- Never use any oven function if the pizza plate is not in position.
- The appliance becomes very hot during use. Oven gloves should always be worn.
- If you like oil on your pizza, it is best to add it after removal from the oven since oil stains on the pizza plate are unsightly and may reduce its efficiency.



8.2 Attention



- *Grilling processes must never last more than 60 minutes.*
- *The oven door must be closed during grill and grill + rotisserie cooking operations.*
- *To prevent hazardous overheating, the appliance's glass lid must always be raised when using the oven or grill.*
- *Accessible parts may be very hot during and after use of the grill; keep children well away from the appliance.*
- *During rotisserie cooking operations, one of the pans supplied with the cooker should be placed on the bottom of the oven, on the bottom runners, to collect any grease and fat produced.*
- *When using the oven, remove all unused pans and shelves from its interior.*
- *During cooking, do not cover the bottom of the oven with aluminium or tin foil, and do not place pans or trays on it; this may damage the enamel coating. If you wish to use greaseproof paper, position it so that it does not interfere with the hot air circulation inside the oven.*

8.3 To save energy

The pizza stone acts as a heat reservoir. This allows energy consumption to be reduced, especially in cooking operations requiring pre-heating or medium-long times.

In these cases, simply turn the thermostat to zero 10-12 minutes before the end of the cooking time.

The heat gradually emitted by the refractory stone will ensure that the cooking temperature is maintained.



9. ACCESSORIES AVAILABLE

The oven is fitted with **4 runners** for placing trays and shelves at different heights.



Oven shelf: for cooking food on plates, small cakes or roasts or foods requiring light grilling.

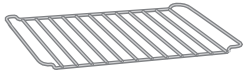

Tray grid: for placing on top of a tray for cooking foods which may drip.

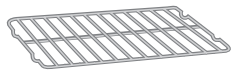

Oven tray: useful for collecting fat from foods placed on the grid above.

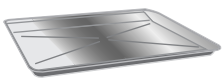

Baking tray: useful for cooking cakes, pizza and confectionery.

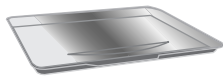

Rotisserie rod: useful for cooking chicken, sausages and all foods which require uniform cooking over their entire surface.



Main oven rotisserie frame: for fitting onto the oven runners before the rotisserie rod is used.

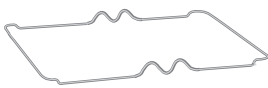

Chromium-plated gripper: useful for removing hot shelves and trays.

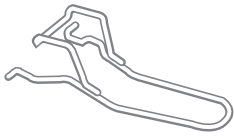

Roof liner: remove it to simplify cleaning inside the oven.

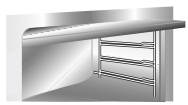



Instructions for the User

GB-IE

Pizza plate: specially designed for cooking pizza. For use as described in point "8 Using the "pizza" function".



Optional accessories

The bottom plinth and self-cleaning oven liners can be ordered through our Authorised Service Centres.



Before using accessories, read the accompanying instructions carefully.

Two optional hob cooking accessories can also be ordered through our Authorised Service Centres:

Gas burner griddle plate: this optional plate is for fitting on the hob **instead of** the right-hand (fish) pan stand. Take care that the griddle plate feet are resting firmly on the hob to avoid all risk of tipping.

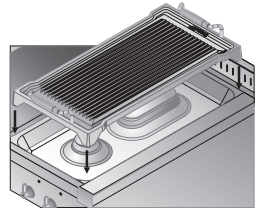

Barbecue grill: this grill is for fitting on the barbecue element **instead of** the aluminium griddle plate.





10. COOKING ADVICE



The oven should always be preheated in fan mode to 30/40°C above the cooking temperature. This considerably shortens cooking times and reduces electricity consumption, as well as giving better results.



The oven door must be closed during cooking operations.

10.1 Conventional cooking (left/right oven)



FUNCTION SELECTOR



THERMOSTAT SET AT 50 - 250°C



THERMOSTAT SET AT 50 - 220°C



This conventional cooking method, with heat from above and below, is suitable for cooking food on just one shelf. The oven must be preheated to the preset temperature. Do not place the food in the oven until the thermostat light goes out. Very fatty meats can be placed inside the oven when it is still cold. Place frozen meat in the oven directly, without thawing. The only precaution required is to set temperatures about 20°C lower and cooking times about 1/4 longer than for fresh meat.



Use deep containers to prevent splashes from dirtying the sides of the oven.





Instructions for the User



10.2 Hot air cooking (left-hand oven)

FUNCTION SELECTOR	
THERMOSTAT SET AT 50 - 250°C	



This system is suitable for cooking on several shelves, even with foods of different kinds (fish, meat, etc.) without cross-contamination of flavours or smells. The air circulation inside the oven ensures uniform heat distribution. Preheating is not necessary.



Multiple cooking is possible provided that all foods require the same temperature.

10.3 Grilling (left/right oven)

FUNCTION SELECTOR	
THERMOSTAT AT MAXIMUM SETTING	
THERMOSTAT AT MAXIMUM SETTING	



Used for quick browning of foods. The tray should be placed on the top runner. For short processes and small amounts, place the shelf on the third runner from the bottom. For longer cooking times and grilling, place the shelf on lower runners, depending on the size of the food.

The oven door must be close while cooking is in progress.

Instructions for the User



10.4 Hot-air grilling (left/right oven)

FUNCTION SELECTOR	
THERMOSTAT FROM 50° C TO 250°C	
THERMOSTAT FROM 50° TO 280°C	

Allows uniform heat distribution with better penetration to the core of foods. Foods are lightly browned on the outside but still soft on the inside.

During cooking the oven door must be closed, and the maximum heating time must not exceed 60 minutes

10.5 Defrosting (left-hand oven)

FUNCTION SELECTOR	
THERMOSTAT SET ON 0	



The air movement provided by the fan alone thaws foods more quickly. The air circulating inside the oven is at room temperature.



Defrosting at room temperature has the advantage that the food's flavour and appearance are retained intact.



Instructions for the User

GB-IE

10.6 Rotisserie cooking (left-hand oven)



FUNCTION SELECTOR



THERMOSTAT SET AT 50 -200°C



3

Recommended for small pieces of meat.

Prepare the rotisserie rod with the food, tightening the screws **A** of the prongs. Fit the shelf **B** onto the third runners from the bottom. Remove the handle **D** and position the rotisserie rod so that the pulley **E** is still in the guides on the shelf **B**. Push the shelf **B** fully in until the tip of the rotisserie rod enters the hole **C** on the rear of the oven. Place a drip tray **F** on the bottom shelf and pour a little water into it to prevent smoke from forming.



It is normal for the thermostat light to switch on and off at regular intervals during cooking; it indicates that the temperature inside the oven is being kept constant.

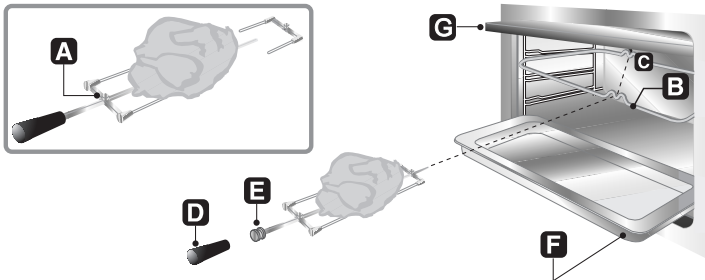



10.7 Recommended cooking tables

Cooking times, for meat in particular, vary depending on the food's thickness and quality and personal preference.

CONVENTIONAL COOKING



	RUNNER HEIGHT FROM BOTTOM	TEMPERATURE (°C)	TIME IN MINUTES (*)
PASTA			
LASAGNE	2 - 3	210 - 230	30
PASTA BAKES	2 - 3	210 - 230	40
MEAT			
ROAST VEAL	2	170 - 200	30 - 40 PER KG.
ROAST BEEF	2	210 - 240	30 - 40 PER KG.
ROAST PORK	2	170 - 200	30 - 40 PER KG.
CHICKEN	2	170 - 200	45 - 60
DUCK	2	170 - 200	45 - 60
GOOSE-TURKEY	2	140 - 170	45 - 60
RABBIT	2	170 - 200	50 - 60
LEG OF LAMB	1	170 - 200	15 PER KG.
ROAST FISH	1 - 2	170 - 200	DEPENDING ON SIZE
PIZZA	1 - 2	210 - 240	40 - 45
CONFECTIONERY			
MERINGUES	1 - 2	50 - 70	60 - 90
PASTRY	1 - 2	170 - 200	15 - 20
SPONGE CAKE	1 - 2	165	35 - 45
BISCUITS	1 - 2	150	30 - 50
CROISSANTS	1 - 2	170 - 200	40 - 45
FRUIT CAKE	1 - 2	170 - 200	20 - 30

(*) = WITH OVEN PREHEATED

GRILLING



	RUNNER POSITION FROM THE BOTTOM	TIME IN MINUTES	
		1ST SIDE	2ND SIDE
PORK CUTLET	4	7 - 9	5 - 7
PORK FILLET	3	9 - 11	5 - 9
FILLET STEAK	3	9 - 11	9 - 11
SLICED LIVER	4	2 - 3	2 - 3
VEAL ESCALOPE	4	7 - 9	5 - 7
HALF CHICKEN	3	9 - 14	9 - 11
SAUSAGE	4	7 - 9	5 - 6
MEATBALLS	4	7 - 9	5 - 6
FISH FILLET	4	5 - 6	3 - 4
TOASTED SANDWICHES	4	2 - 4	2 - 3



Instructions for the User

GB-IE

HOT-AIR COOKING



	RUNNER HEIGHT FROM BOTTOM	TEMPERATURE (°C)	TIME IN MINUTES
PASTA			
LASAGNE	2	190 - 210	20 - 25
PASTA BAKES	2	190 - 210	25 - 30
CREOLE RICE	2	190 - 220	20 - 25
MEAT			
ROAST VEAL	2	150 - 170	65 - 90
ROAST PORK	2	150 - 160	70 - 100
ROAST BEEF	2	160 - 170	65 - 90
FILLET STEAK	2	160 - 180	35 - 45
ROAST LAMB	2	130 - 150	100 - 130
RARE ROAST BEEF	2	170 - 180	40 - 45
ROAST CHICKEN	2	170	70 - 90
ROAST DUCK	2	160 - 170	100 - 160
ROAST TURKEY	2	150 - 160	160 - 240
ROAST RABBIT	2	150 - 160	80 - 100
ROAST HARE	2	160 - 170	30 - 50
ROAST PIGEON	2	140 - 170	15 - 25
FISH	2 - 3	150 - 170	DEPENDING ON SIZE
PIZZA	2 - 3	210 - 240	30 - 50
SWEETS (CONFECTIONERY)			
SPONGE CAKE	2 - 3	150 - 170	35 - 45
FRUIT CAKE	2 - 3	170 - 190	40 - 50
LIGHT SPONGE CAKE	2 - 3	190 - 220	25 - 35
CROISSANTS	2 - 3	160 - 170	40 - 60
APPLE TART	1 - 2	150	25 - 35
BISCUIT PUDDING	2 - 3	160 - 170	30 - 40
BREAD	2 - 3	190 - 210	40
TOASTED SANDWICHES	1 - 2	220 - 240	7



For barbecue cooking, preheating of about 15 minutes is recommended.



11. CLEANING AND MAINTENANCE



Never use a jet of steam for cleaning the inside of the oven.

11.1 Cleaning stainless steel



To keep stainless steel in good condition, it must be cleaned regularly, after each use, first allowing it to cool.

11.1.1 Routine daily cleaning

When cleaning and caring for stainless steel surfaces, always use **only** specific products which do not contain abrasives or chlorine-based acids.

Instructions for use: pour the product onto a damp cloth and wipe over the surface, then rinse thoroughly and dry with a soft cloth or chamois leather.

11.1.2 Food stains or spills

Never use metal scouring pads or sharp scrapers; they will damage surfaces.

Use ordinary non-abrasive products for steel, with the aid of wooden or plastic utensils if necessary.

Rinse thoroughly and dry with a soft cloth or chamois leather.

Do not allow spills of foods with high sugar content (e.g. jam) to dry inside the oven. If they dry for too long, they might damage the enamel coating of the inside of the oven.





Instructions for the User

GB-IE

11.2 Cleaning the hob components



Before carrying out any operation involving access to live parts, disconnect the appliance from the electricity supply.

11.2.1 Barbecue griddle plate

After leaving it to cool, remove the barbecue plate by lifting it from the front as shown here, taking care not to spill the residues that have collected in the channels at the sides. Clean it with an ordinary detergent and a non-abrasive sponge.

Take care not to spill the residues that collect in the channel.

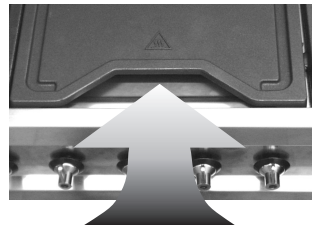

11.2.2 Basin

To remove the basin underneath the barbecue heating element:

1. Remove the griddle plate as described in point 10.2.1;
2. Lift the heating element and secure it by sliding the retainer to the right (as shown here);
3. Remove the basin using the two handles and clean it with a specific stainless steel detergent and non-abrasive sponge.

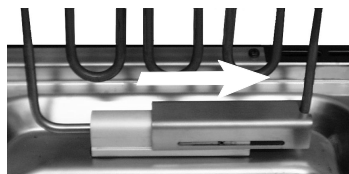

11.2.3 The pan stands

Remove the right-hand pan stands (griddle+fish burner) as shown here. The left-hand pan stands do not have to be removed in any particular order. Wash them in warm water with a non-abrasive detergent, taking care to remove all deposits. Replace fitting first the side pan stand then the griddle plate.

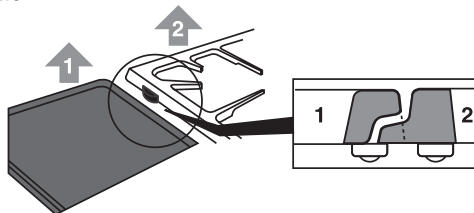

Instructions for the User



11.2.4 The burner caps, flame diffuser rings and burners

The burner caps and flame diffuser rings can be removed for easier cleaning; wash them in hot water and non-abrasive detergent, taking care to remove all deposits, and wait for them to **dry completely**.

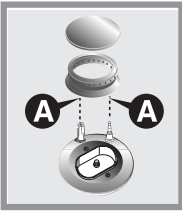

Replace the burner caps on their rings, making sure that the holes **A** are perfectly centered with the circular projections **B** on the burners.



Never wash these components in the dishwasher.

11.2.5 The plugs and thermocouples

For best performance, the ignition plugs and thermocouples must always be kept thoroughly clean. Check them frequently and if necessary clean them with a wet cloth. Remove any dry residues with a wooden toothpick or a needle.

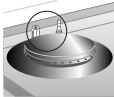

11.3 Cleaning the ovens (without self-cleaning liners)



To keep the ovens in good condition, they must be cleaned regularly, after allowing them to cool down. Remove all removable parts. Remove the side runners by lifting them at the front and extracting them from the hole at the back.



- Clean the oven shelves and side runners with hot water and non-abrasive detergents, rinse and dry.



Instructions for the User



11.3.1 Oven liners

The oven is fitted with enamelled liners that are continuously self-cleaning.

These liners simplify cleaning of the oven and ensure it continues to perform well over time.

11.3.2 Using the self-cleaning liners

To keep the inside of the oven clean and free from food residues and unpleasant smells, it should periodically be operated empty at a temperature of at least 200° C for a time varying between 30 and 60 minutes. This allows the self-cleaning liners to oxidise any deposits present, which can then be wiped away with a damp sponge once the oven has cooled.

11.3.3 Maintenance of self-cleaning liners

The liners should not be cleaned using abrasive creams and ordinary cleaners. Simply wipe with a damp sponge to avoid damaging the special enamel coating.

11.3.4 Removing the self-cleaning liners

Remove all accessories from the inside of the oven and proceed as follows:

1. Remove the side runners (fig.1);
2. Extract the side liners "F" and "G" (fig. 2);
3. Extract the back liner "A" after undoing the threaded ring-nut "C" (fig. 2);
4. Replace the liners in their original positions.

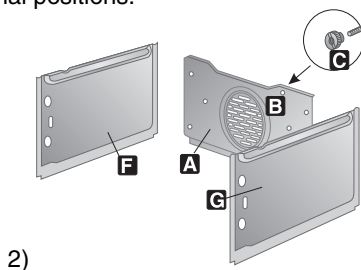
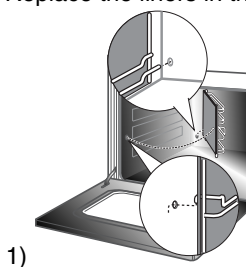



11.4 Door glazing

The glass in the door should always be kept thoroughly clean. Use absorbent kitchen roll; remove stubborn dirt with a damp sponge and ordinary detergent.



Do not use abrasive or corrosive cleaners for cleaning the door glazing. (e.g. powder products, oven-cleaner sprays, stain removers and metal scouring pads).

Do not use rough or abrasive materials or sharp metal scrapers to clean the oven's glass doors since they may scratch the surface and cause the glass to shatter.

11.5 Cleaning the oven bottom (right-hand oven)

To clean the bottom of the oven, proceed as follows with the oven cold.

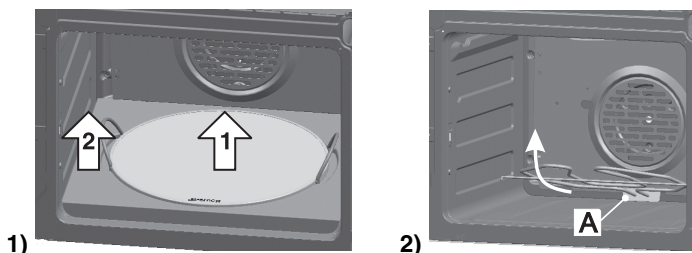

Remove the pizza plate and then the base to which it is fixed (Fig. 1).

Lift the base a few mm and then extract it from the oven.

Now lift the end of the heating element next to the door of the oven and clean the bottom. When the operation is complete, damp parts should be dried thoroughly.

- **NEVER USE A JET OF STEAM FOR CLEANING THE INSIDE OF THE OVEN.**
- Clean the oven shelf and side runners with hot water and non-abrasive detergents, rinse and dry.
- For easier cleaning, the door can be removed (see point 8.3).
- The oven should be operated at the maximum heat setting for 15/20 minutes after use of specific products, to burn off the residues left inside the oven.

The pizza plate must be washed separately;



Instructions for the User

GB-IE

- Before cleaning, remove any dirt burnt onto the stone with the aid of a metal spatula or a scraper of the kind used for cleaning ceramic hobs;
- For best results, the stone must still be warm; otherwise, wash it in hot water;
- Use metal mesh or non-abrasive scouring pads, dipped in lemon or vinegar;
- Never use detergents;
- Never wash in the dishwasher;
- Never leave the stone to soak;
- The damp stone must not be used for a least 8 hours after the end of the cleaning procedures;
- Over time, slight cracks may appear on the surface of the stone. This is due to the normal expansion of the stone's finishing glazes at high temperatures.
- To put the pizza plate base back in place, push it firmly down against the oven's bottom panel and ensure it engages with the plate of the pizza heating element (detail **A** Fig. 2)



12. EXTRAORDINARY MAINTENANCE

Occasionally, the ovens will require minor servicing procedures or the replacement of parts subject to wear and tear, such as gaskets, light bulbs, etc. The specific operations for each procedure of this kind are provided below.



Before carrying out any operation involving access to live parts, disconnect the appliance from the electricity supply.

12.1 Changing the light bulbs

Remove the protective cover **A** by unscrewing it anticlockwise and replace the bulb **B** with another of the same type. Replace the protective cover **A**.

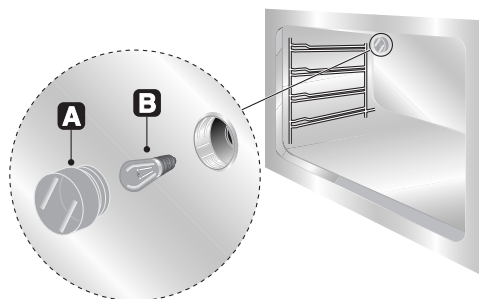

Use only light bulbs approved for ovens (T 300°C).



Instructions for the User

GB-IE

12.2 Removing the door

Open the door completely and insert the pins (supplied) into the holes from the inside. Close the door to an angle of about 45° and lift it off. To reassemble, fit the hinges into their grooves, then lower the door into place and extract the pins.

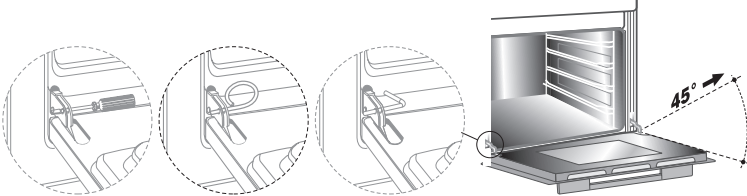

12.3 Oven door gaskets

To allow thorough cleaning of the oven, the door gaskets can be removed. Before removing the gaskets, remove the oven doors as described above. Once the doors have been removed, lift the tangs at the corners as shown on the right.

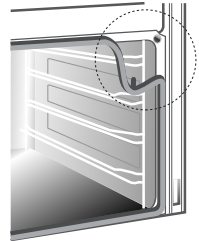

12.4 Greasing the gas taps

Over time, the gas taps may become stiff or jam. Clean their insides and change their lubricating grease. **This operation must be carried out by a skilled technician.**

