



# **ExSite™ Series Explosionproof Power Module**



**IPSXM-2 and IPSXM-7**

**C313M-D (8/05)**



# Contents

---

Important Safety Instructions .....	4
Getting Started .....	5
Install the Power Module .....	6
Connect Wiring .....	7
DIP Switch Settings .....	8
Protocol Settings .....	8
Receiver Address Settings (SW1) .....	8
Termination Setting (SW2) .....	8
Baud Settings (SW3) .....	8
Tables .....	9
Specifications .....	14

## List of Illustrations

1 Attach Power Module to Mounting Surface .....	6
2 Lightly Lubricate and Install O-Ring .....	6
3 Default DIP Switch Settings .....	8

## List of Tables

A P Protocol Receiver Address .....	9
B D Protocol Receiver Address .....	10

# Important Safety Instructions

---

1. Read these instructions.
2. Keep these instructions.
3. Heed all warnings.
4. Follow all instructions.
5. Do not block any ventilation openings. Install in accordance with the manufacturer's instructions.
6. To reduce the risk of ignition of hazardous atmospheres, disconnect the equipment from the supply circuit before opening. Keep assembly tightly closed when in operation.
7. The maximum ambient temperature range is -76°F to 140°F (-60°C to 60°C).
8. Only use attachments/accessories specified by the manufacturer.
9. Refer all servicing to qualified service personnel. Servicing is required when the apparatus has been damaged in any way, such as power-supply cord or plug is damaged, liquid has been spilled or objects have fallen into the apparatus, the apparatus has been exposed to rain or moisture, does not operate normally, or has been dropped.
10. Installation should be done only by qualified personnel and conform to all local codes.
11. Unless the unit is specifically marked as a NEMA Type 3, 3R, 3S, 4, 4X, 6, or 6P enclosure, it is designed for indoor use only and it must not be installed where exposed to rain and moisture.
12. Use only installation methods and materials capable of supporting four times the maximum specified load.
13. Use stainless steel hardware to fasten the mount to outdoor surfaces.
14. AN ALL-POLE MAINS SWITCH with a contact separation of at least 3 mm in each pole shall be incorporated in the electrical installation of the building.
15. A readily accessible disconnect device shall be incorporated in the building installation wiring.
16. CAUTION: These servicing instructions are for use by qualified service personnel only. To reduce the risk of electric shock do not perform any servicing other than that contained in the operating instructions unless you are qualified to do so.
17. Only use replacement parts recommended by Pelco.

The product and/or manual may bear the following marks:

 **WARNING:** This symbol indicates that dangerous voltage constituting a risk of electric shock is present within this unit.

 This symbol indicates that there are important operating and maintenance instructions in the literature accompanying this unit.

 **WARNING:** HAZARDOUS MOVING PARTS. KEEP FINGERS AND OTHER BODY PARTS AWAY.

 **WARNING:** To reduce the risk of ignition of hazardous atmospheres, disconnect the equipment from the supply circuit before opening. Keep assembly tightly closed when operating.

 **WARNING:** To reduce the risk of ignition of hazardous atmospheres, conduit runs must have a sealing fitting connected within 2 inches of the enclosure.

 **TO REDUCE THE RISK OF IGNITION DO NOT OPEN WHEN AN EXPLOSIVE GAS ATMOSPHERE MAY BE PRESENT.**

<b>CAUTION:</b>
-----------------

<b>RISK OF ELECTRIC SHOCK. DO NOT OPEN.</b>
---

# Getting Started

---

Thank you for purchasing Pelco's ExSite™ Series explosionproof integrated positioning system. This manual includes instructions for installing the power module for the ExSite Series system. For complete system installation instructions refer to the installation manual placed in the pan and tilt box.

 **DANGER:** Do not connect the power module to a supply circuit unless all ExSite system components (pan and tilt, camera module and power module) are installed.

Once the complete system is installed refer to the operation/programming manual shipped with the camera module for instructions on how to operate and program your system.

# Install the Power Module

Attach the power module to the mounting surface. Use only installation methods and materials capable of supporting four times the maximum specified load of the system (220 lb/100 kg).

**NOTE:** If required, install the optional TXB translator, fiber module, or UTP board before installing the power module. Refer to the installation instructions supplied with the TXB translator, fiber module, or UTP board for installation instructions.

To install the power module, refer to Figure 1 and do the following:

1. Make sure the threads of the power module and the threads of the supplied M10 x 16 mm stainless steel bolts are free of dirt and debris.
2. Apply a generous amount of thread locking compound (supplied) to the threads of the power module and the threads of the stainless steel bolts.
3. Face the conduit fitting of the power module towards the mating conduit fitting of the installation.
4. Secure the power module to the mounting surface with the supplied 8 mm Allen wrench and four M10 x 16 mm stainless steel bolts. Tighten the bolts to 25 to 27 ft-lb (34 to 37 Nm). The thread compound supplied must cure for one hour. Allow for this cure period prior to completing the installation.

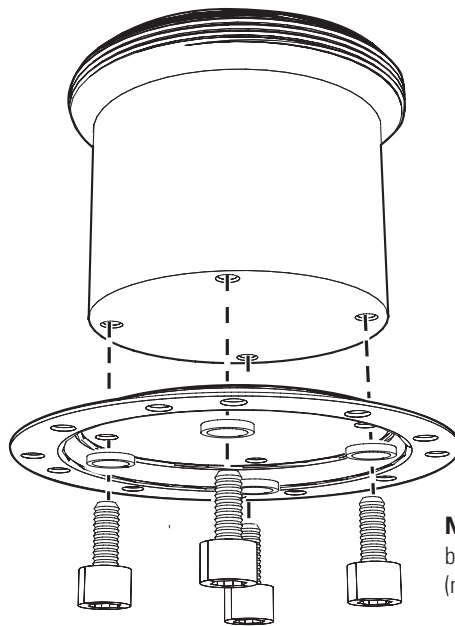

**NOTE:** Figure 1 shows the power module being installed on a PXM100 pedestal mount (not supplied).

**Figure 1.** Attach Power Module to Mounting Surface

5. Lightly apply O-ring lubricant (supplied) to the O-ring, and then install the O-ring on the rim of the power module (refer to Figure 2).

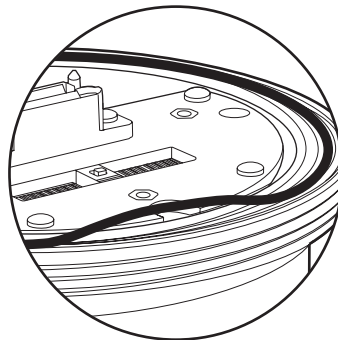

**Figure 2.** Lightly Lubricate and Install O-Ring

# Connect Wiring

Refer to the following information to connect the wires and cables as required.

**⚠ WARNING:** When installing this unit, provide access to the communication wires (TX- and TX+) to allow connection to the system for future software upgrades. Connectors must be installed so that the integrity of the hazardous location is maintained. These communication wires are required even if the system uses Coaxitron® control. Maximum wire distance for RS-422 data wires is 4,000 ft (1,219 m).

## NOTES:

- Relay 3 is allocated specifically for an external washer (not supplied by Pelco).
- All relays are specified for 32 VDC, 0.5 A.
- Wiring/cable for UTP and fiber optic are not provided on the wire harness. The installer must provide UTP and fiber optic connections.

## Configuration of Wire Harness

Wire Color	Function
White/Orange	TX+
White/Blue	TX-
Red	RX+
Green	RX-
Violet/White	Relay 3 NC (washer only)
White/Red	Relay 3 COM (washer only)
Green/Black	Relay 3 NO (washer only)
Gray/White	Relay 2 NC
Yellow	Relay 2 COM
Violet	Relay 2 NO
Brown	Relay 1 NC
Gray	Relay 1 COM
White/Yellow/Black	Relay 1 NO
White/Black/Green	Alarm COM
White/Red/Black	Alarm 7
White/Brown/Black	Alarm 6
Orange	Alarm 5
White/Orange/Black	Alarm 4
White/Blue/Black	Alarm 3
White/Brown	Alarm 2
White/Black	Alarm 1

## Power Connections 24 VAC

Wire Color	Function
Red	AC Hi
Black	AC Low

## Power Connections 100-240 VAC

Wire Color	Function
Black	AC Hi
White	AC Low
Green/Yellow	Earth Ground

## Video Coaxial Cable Requirements

Cable Type*	Maximum Distance
RG59/U	750 ft (229 m)
RG6/U	1,000 ft (305 m)
RG11/U	1,500 ft (457 m)

\*Cable requirements:  
 75-ohm impedance  
 All-copper center conductor  
 All-copper braided shield with 95% braid coverage

## Wiring Distances

The following are the recommended maximum distances for 24 VAC and 100-240 VAC applications and are calculated with a 10 percent voltage drop. (Ten percent is generally the maximum allowable voltage drop for AC-powered devices.)

Power	Wire Gauge			
	18 (1.0 mm <sup>2</sup> )	16 (1.5 mm <sup>2</sup> )	14 (2.5 mm <sup>2</sup> )	12 (3.5 mm <sup>2</sup> )
24 VAC	27 ft (8 m)	43 ft (13 m)	69 ft (21 m)	110 ft (33 m)
100-240 VAC	75 ft (23 m)	120 ft (36 m)	190 ft (58 m)	310 ft (94 m)

**NOTE:** Power consumption is 120 VA per unit. Use a powersource with a minimum of 150 VA.

# DIP Switch Settings

Configure the receiver address, termination, and baud setting for the system. The DIP switches to configure these settings are located on the top of the power module.

**NOTE:** No DIP switch settings are required for Coaxitron® control.

Figure 3 shows the default settings for the DIP switches. Refer to the following to configure the ExSite system settings.

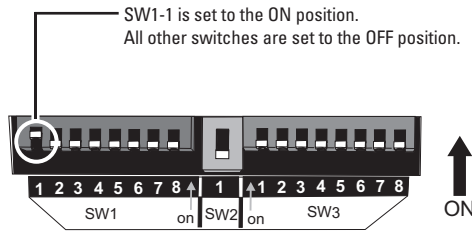

**Figure 3.** Default DIP Switch Settings

## Protocol Settings

The ExSite system automatically detects the type of protocol. No switch settings are required to set Coaxitron or RS-422 P and D protocols.

### Receiver Address Settings (SW1)

The default address is 2 for P protocol. Refer to Table A for address settings that use P protocol. Maximum number of receivers is 32.

The default address is 1 for D protocol. Refer to Table B for address settings that use D protocol. Maximum number of receivers is 254.

### Termination Setting (SW2)

When connecting more than one ExSite system to a single controller, terminate the unit farthest from the controller. Termination is required only for the last unit in the series. The unit is shipped from the factory in the unterminated (OFF) position. To terminate the unit, set the SW2 switch to the ON position.

### Baud Settings (SW3)

Pelco's D-type controllers are set for 2400 baud. The default setting for the unit is 2400 baud. If you are using a Pelco D-type controller, do not reset the SW3 switches.

P-type controllers can operate at 2400, 4800, and 9600 baud. Set the SW3 switches (6, 7, and 8), located on the top of the power module, to the same baud as the P-type controller.

### Switch Settings for SW3

Switch Number	SW3-6	SW3-7	SW3-8
2400 Baud	Off	Off	Off
4800 Baud	On	Off	Off
9600 Baud	Off	On	Off



# Tables

**Table A. P Protocol Receiver Address**

ADDRESS	SWITCH SETTING							
	SW1-1	SW1-2	SW1-3	SW1-4	SW1-5	SW1-6	SW1-7	SW1-8
1	OFF	OFF	OFF	OFF	OFF	OFF	OFF	OFF
2	ON	OFF	OFF	OFF	OFF	OFF	OFF	OFF
3	OFF	ON	OFF	OFF	OFF	OFF	OFF	OFF
4	ON	ON	OFF	OFF	OFF	OFF	OFF	OFF
5	OFF	OFF	ON	OFF	OFF	OFF	OFF	OFF
6	ON	OFF	ON	OFF	OFF	OFF	OFF	OFF
7	OFF	ON	ON	OFF	OFF	OFF	OFF	OFF
8	ON	ON	ON	OFF	OFF	OFF	OFF	OFF
9	OFF	OFF	OFF	ON	OFF	OFF	OFF	OFF
10	ON	OFF	OFF	ON	OFF	OFF	OFF	OFF
11	OFF	ON	OFF	ON	OFF	OFF	OFF	OFF
12	ON	ON	OFF	ON	OFF	OFF	OFF	OFF
13	OFF	OFF	ON	ON	OFF	OFF	OFF	OFF
14	ON	OFF	ON	ON	OFF	OFF	OFF	OFF
15	OFF	ON	ON	ON	OFF	OFF	OFF	OFF
16	ON	ON	ON	ON	OFF	OFF	OFF	OFF

ADDRESS	SWITCH SETTING							
	SW1-1	SW1-2	SW1-3	SW1-4	SW1-5	SW1-6	SW1-7	SW1-8
17	OFF	OFF	OFF	OFF	ON	OFF	OFF	OFF
18	ON	OFF	OFF	OFF	ON	OFF	OFF	OFF
19	OFF	ON	OFF	OFF	ON	OFF	OFF	OFF
20	ON	ON	OFF	OFF	ON	OFF	OFF	OFF
21	OFF	OFF	ON	OFF	ON	OFF	OFF	OFF
22	ON	OFF	ON	OFF	ON	OFF	OFF	OFF
23	OFF	ON	ON	OFF	ON	OFF	OFF	OFF
24	ON	ON	ON	OFF	ON	OFF	OFF	OFF
25	OFF	OFF	OFF	ON	ON	OFF	OFF	OFF
26	ON	OFF	OFF	ON	ON	OFF	OFF	OFF
27	OFF	ON	OFF	ON	ON	OFF	OFF	OFF
28	ON	ON	OFF	ON	ON	OFF	OFF	OFF
29	OFF	OFF	ON	ON	ON	OFF	OFF	OFF
30	ON	OFF	ON	ON	ON	OFF	OFF	OFF
31	OFF	ON	ON	ON	ON	OFF	OFF	OFF
32	ON	ON	ON	ON	ON	OFF	OFF	OFF

**Table B. D Protocol Receiver Address**

ADDRESS	SWITCH SETTING							
	SW1-1	SW1-2	SW1-3	SW1-4	SW1-5	SW1-6	SW1-7	SW1-8
1	ON	OFF	OFF	OFF	OFF	OFF	OFF	OFF
2	OFF	ON	OFF	OFF	OFF	OFF	OFF	OFF
3	ON	ON	OFF	OFF	OFF	OFF	OFF	OFF
4	OFF	OFF	ON	OFF	OFF	OFF	OFF	OFF
5	ON	OFF	ON	OFF	OFF	OFF	OFF	OFF
6	OFF	ON	ON	OFF	OFF	OFF	OFF	OFF
7	ON	ON	ON	OFF	OFF	OFF	OFF	OFF
8	OFF	OFF	OFF	ON	OFF	OFF	OFF	OFF
9	ON	OFF	OFF	ON	OFF	OFF	OFF	OFF
10	OFF	ON	OFF	ON	OFF	OFF	OFF	OFF
11	ON	ON	OFF	ON	OFF	OFF	OFF	OFF
12	OFF	OFF	ON	ON	OFF	OFF	OFF	OFF
13	ON	OFF	ON	ON	OFF	OFF	OFF	OFF
14	OFF	ON	ON	ON	OFF	OFF	OFF	OFF
15	ON	ON	ON	ON	OFF	OFF	OFF	OFF
16	OFF	OFF	OFF	OFF	ON	OFF	OFF	OFF
17	ON	OFF	OFF	OFF	ON	OFF	OFF	OFF
18	OFF	ON	OFF	OFF	ON	OFF	OFF	OFF
19	ON	ON	OFF	OFF	ON	OFF	OFF	OFF
20	OFF	OFF	ON	OFF	ON	OFF	OFF	OFF
21	ON	OFF	ON	OFF	ON	OFF	OFF	OFF
22	OFF	ON	ON	OFF	ON	OFF	OFF	OFF
23	ON	ON	ON	OFF	ON	OFF	OFF	OFF
24	OFF	OFF	OFF	ON	ON	OFF	OFF	OFF

ADDRESS	SWITCH SETTING							
	SW1-1	SW1-2	SW1-3	SW1-4	SW1-5	SW1-6	SW1-7	SW1-8
25	ON	OFF	OFF	ON	ON	OFF	OFF	OFF
26	OFF	ON	OFF	ON	ON	OFF	OFF	OFF
27	ON	ON	OFF	ON	ON	OFF	OFF	OFF
28	OFF	OFF	ON	ON	ON	OFF	OFF	OFF
29	ON	OFF	ON	ON	ON	OFF	OFF	OFF
30	OFF	ON	ON	ON	ON	OFF	OFF	OFF
31	ON	ON	ON	ON	ON	OFF	OFF	OFF
32	OFF	OFF	OFF	OFF	OFF	ON	OFF	OFF
33	ON	OFF	OFF	OFF	OFF	ON	OFF	OFF
34	OFF	ON	OFF	OFF	OFF	ON	OFF	OFF
35	ON	ON	OFF	OFF	OFF	ON	OFF	OFF
36	OFF	OFF	ON	OFF	OFF	ON	OFF	OFF
37	ON	OFF	ON	OFF	OFF	ON	OFF	OFF
38	OFF	ON	ON	OFF	OFF	ON	OFF	OFF
39	ON	ON	ON	OFF	OFF	ON	OFF	OFF
40	OFF	OFF	OFF	ON	OFF	ON	OFF	OFF
41	ON	OFF	OFF	ON	OFF	ON	OFF	OFF
42	OFF	ON	OFF	ON	OFF	ON	OFF	OFF
43	ON	ON	OFF	ON	OFF	ON	OFF	OFF
44	OFF	OFF	ON	ON	OFF	ON	OFF	OFF
45	ON	OFF	ON	ON	OFF	ON	OFF	OFF
46	OFF	ON	ON	ON	OFF	ON	OFF	OFF
47	ON	ON	ON	ON	OFF	ON	OFF	OFF
48	OFF	OFF	OFF	OFF	ON	ON	OFF	OFF

*(Continued on next page)*

**Table B. D Protocol Receiver Address (Continued)**

ADDRESS	SWITCH SETTING							
	SW1-1	SW1-2	SW1-3	SW1-4	SW1-5	SW1-6	SW1-7	SW1-8
49	ON	OFF	OFF	OFF	ON	ON	OFF	OFF
50	OFF	ON	OFF	OFF	ON	ON	OFF	OFF
51	ON	ON	OFF	OFF	ON	ON	OFF	OFF
52	OFF	OFF	ON	OFF	ON	ON	OFF	OFF
53	ON	OFF	ON	OFF	ON	ON	OFF	OFF
54	OFF	ON	ON	OFF	ON	ON	OFF	OFF
55	ON	ON	ON	OFF	ON	ON	OFF	OFF
56	OFF	OFF	OFF	ON	ON	ON	OFF	OFF
57	ON	OFF	OFF	ON	ON	ON	OFF	OFF
58	OFF	ON	OFF	ON	ON	ON	OFF	OFF
59	ON	ON	OFF	ON	ON	ON	OFF	OFF
60	OFF	OFF	ON	ON	ON	ON	OFF	OFF
61	ON	OFF	ON	ON	ON	ON	OFF	OFF
62	OFF	ON	ON	ON	ON	ON	OFF	OFF
63	ON	ON	ON	ON	ON	ON	OFF	OFF
64	OFF	OFF	OFF	OFF	OFF	OFF	ON	OFF
65	ON	OFF	OFF	OFF	OFF	OFF	ON	OFF
66	OFF	ON	OFF	OFF	OFF	OFF	ON	OFF
67	ON	ON	OFF	OFF	OFF	OFF	ON	OFF
68	OFF	OFF	ON	OFF	OFF	OFF	ON	OFF
69	ON	OFF	ON	OFF	OFF	OFF	ON	OFF
70	OFF	ON	ON	OFF	OFF	OFF	ON	OFF
71	ON	ON	ON	OFF	OFF	OFF	ON	OFF
72	OFF	OFF	OFF	ON	OFF	OFF	ON	OFF
73	ON	OFF	OFF	ON	OFF	OFF	ON	OFF
74	OFF	ON	OFF	ON	OFF	OFF	ON	OFF
75	ON	ON	OFF	ON	OFF	OFF	ON	OFF
76	OFF	OFF	ON	ON	OFF	OFF	ON	OFF
77	ON	OFF	ON	ON	OFF	OFF	ON	OFF
78	OFF	ON	ON	ON	OFF	OFF	ON	OFF
79	ON	ON	ON	ON	OFF	OFF	ON	OFF
80	OFF	OFF	OFF	OFF	ON	OFF	ON	OFF
81	ON	OFF	OFF	OFF	ON	OFF	ON	OFF
82	OFF	ON	OFF	OFF	ON	OFF	ON	OFF
83	ON	ON	OFF	OFF	ON	OFF	ON	OFF
84	OFF	OFF	ON	OFF	ON	OFF	ON	OFF
85	ON	OFF	ON	OFF	ON	OFF	ON	OFF
86	OFF	ON	ON	OFF	ON	OFF	ON	OFF
87	ON	ON	ON	OFF	ON	OFF	ON	OFF
88	OFF	OFF	OFF	ON	ON	OFF	ON	OFF
89	ON	OFF	OFF	ON	ON	OFF	ON	OFF
90	OFF	ON	OFF	ON	ON	OFF	ON	OFF
91	ON	ON	OFF	ON	ON	OFF	ON	OFF
92	OFF	OFF	ON	ON	ON	OFF	ON	OFF
93	ON	OFF	ON	ON	ON	OFF	ON	OFF
94	OFF	ON	ON	ON	ON	OFF	ON	OFF
95	ON	ON	ON	ON	ON	OFF	ON	OFF

ADDRESS	SWITCH SETTING							
	SW1-1	SW1-2	SW1-3	SW1-4	SW1-5	SW1-6	SW1-7	SW1-8
96	OFF	OFF	OFF	OFF	OFF	ON	ON	OFF
97	ON	OFF	OFF	OFF	OFF	ON	ON	OFF
98	OFF	ON	OFF	OFF	OFF	ON	ON	OFF
99	ON	ON	OFF	OFF	OFF	ON	ON	OFF
100	OFF	OFF	ON	OFF	OFF	ON	ON	OFF
101	ON	OFF	ON	OFF	OFF	ON	ON	OFF
102	OFF	ON	ON	OFF	OFF	ON	ON	OFF
103	ON	ON	ON	OFF	OFF	ON	ON	OFF
104	OFF	OFF	OFF	ON	OFF	ON	ON	OFF
105	ON	OFF	OFF	ON	OFF	ON	ON	OFF
106	OFF	ON	OFF	ON	OFF	ON	ON	OFF
107	ON	ON	OFF	ON	OFF	ON	ON	OFF
108	OFF	OFF	ON	ON	OFF	ON	ON	OFF
109	ON	OFF	ON	ON	OFF	ON	ON	OFF
110	OFF	ON	ON	ON	OFF	ON	ON	OFF
111	ON	ON	ON	ON	OFF	ON	ON	OFF
112	OFF	OFF	OFF	OFF	ON	ON	ON	OFF
113	ON	OFF	OFF	OFF	ON	ON	ON	OFF
114	OFF	ON	OFF	OFF	ON	ON	ON	OFF
115	ON	ON	OFF	OFF	ON	ON	ON	OFF
116	OFF	OFF	ON	OFF	ON	ON	ON	OFF
117	ON	OFF	ON	OFF	ON	ON	ON	OFF
118	OFF	ON	ON	OFF	ON	ON	ON	OFF
119	ON	ON	ON	OFF	ON	ON	ON	OFF
120	OFF	OFF	OFF	ON	ON	ON	ON	OFF
121	ON	OFF	OFF	ON	ON	ON	ON	OFF
122	OFF	ON	OFF	ON	ON	ON	ON	OFF
123	ON	ON	OFF	ON	ON	ON	ON	OFF
124	OFF	OFF	ON	ON	ON	ON	ON	OFF
125	ON	OFF	ON	ON	ON	ON	ON	OFF
126	OFF	ON	ON	ON	ON	ON	ON	OFF
127	ON	ON	ON	ON	ON	ON	ON	OFF
128	OFF	OFF	OFF	OFF	OFF	OFF	OFF	ON
129	ON	OFF	OFF	OFF	OFF	OFF	OFF	ON
130	OFF	ON	OFF	OFF	OFF	OFF	OFF	ON
131	ON	ON	OFF	OFF	OFF	OFF	OFF	ON
132	OFF	OFF	ON	OFF	OFF	OFF	OFF	ON
133	ON	OFF	ON	OFF	OFF	OFF	OFF	ON
134	OFF	ON	ON	OFF	OFF	OFF	OFF	ON
135	ON	ON	ON	OFF	OFF	OFF	OFF	ON
136	OFF	OFF	OFF	ON	OFF	OFF	OFF	ON
137	ON	OFF	OFF	ON	OFF	OFF	OFF	ON
138	OFF	ON	OFF	ON	OFF	OFF	OFF	ON
139	ON	ON	OFF	ON	OFF	OFF	OFF	ON
140	OFF	OFF	ON	ON	OFF	OFF	OFF	ON
141	ON	OFF	ON	ON	OFF	OFF	OFF	ON
142	OFF	ON	ON	ON	OFF	OFF	OFF	ON

*(Continued on next page)*

**Table B. D Protocol Receiver Address (Continued)**

ADDRESS	SWITCH SETTING							
	SW1-1	SW1-2	SW1-3	SW1-4	SW1-5	SW1-6	SW1-7	SW1-8
143	ON	ON	ON	ON	OFF	OFF	OFF	ON
144	OFF	OFF	OFF	OFF	ON	OFF	OFF	ON
145	ON	OFF	OFF	OFF	ON	OFF	OFF	ON
146	OFF	ON	OFF	OFF	ON	OFF	OFF	ON
147	ON	ON	OFF	OFF	ON	OFF	OFF	ON
148	OFF	OFF	ON	OFF	ON	OFF	OFF	ON
149	ON	OFF	ON	OFF	ON	OFF	OFF	ON
150	OFF	ON	ON	OFF	ON	OFF	OFF	ON
151	ON	ON	ON	OFF	ON	OFF	OFF	ON
152	OFF	OFF	OFF	ON	ON	OFF	OFF	ON
153	ON	OFF	OFF	ON	ON	OFF	OFF	ON
154	OFF	ON	OFF	ON	ON	OFF	OFF	ON
155	ON	ON	OFF	ON	ON	OFF	OFF	ON
156	OFF	OFF	ON	ON	ON	OFF	OFF	ON
157	ON	OFF	ON	ON	ON	OFF	OFF	ON
158	OFF	ON	ON	ON	ON	OFF	OFF	ON
159	ON	ON	ON	ON	ON	OFF	OFF	ON
160	OFF	OFF	OFF	OFF	OFF	ON	OFF	ON
161	ON	OFF	OFF	OFF	OFF	ON	OFF	ON
162	OFF	ON	OFF	OFF	OFF	ON	OFF	ON
163	ON	ON	OFF	OFF	OFF	ON	OFF	ON
164	OFF	OFF	ON	OFF	OFF	ON	OFF	ON
165	ON	OFF	ON	OFF	OFF	ON	OFF	ON
166	OFF	ON	ON	OFF	OFF	ON	OFF	ON
167	ON	ON	ON	OFF	OFF	ON	OFF	ON
168	OFF	OFF	OFF	ON	OFF	ON	OFF	ON
169	ON	OFF	OFF	ON	OFF	ON	OFF	ON
170	OFF	ON	OFF	ON	OFF	ON	OFF	ON
171	ON	ON	OFF	ON	OFF	ON	OFF	ON
172	OFF	OFF	ON	ON	OFF	ON	OFF	ON
173	ON	OFF	ON	ON	OFF	ON	OFF	ON
174	OFF	ON	ON	ON	OFF	ON	OFF	ON
175	ON	ON	ON	ON	OFF	ON	OFF	ON
176	OFF	OFF	OFF	OFF	ON	ON	OFF	ON
177	ON	OFF	OFF	OFF	ON	ON	OFF	ON
178	OFF	ON	OFF	OFF	ON	ON	OFF	ON
179	ON	ON	OFF	OFF	ON	ON	OFF	ON
180	OFF	OFF	ON	OFF	ON	ON	OFF	ON
181	ON	OFF	ON	OFF	ON	ON	OFF	ON
182	OFF	ON	ON	OFF	ON	ON	OFF	ON
183	ON	ON	ON	OFF	ON	ON	OFF	ON
184	OFF	OFF	OFF	ON	ON	ON	OFF	ON
185	ON	OFF	OFF	ON	ON	ON	OFF	ON
186	OFF	ON	OFF	ON	ON	ON	OFF	ON
187	ON	ON	OFF	ON	ON	ON	OFF	ON
188	OFF	OFF	ON	ON	ON	ON	OFF	ON
189	ON	OFF	ON	ON	ON	ON	OFF	ON
190	OFF	ON	ON	ON	ON	ON	OFF	ON

ADDRESS	SWITCH SETTING							
	SW1-1	SW1-2	SW1-3	SW1-4	SW1-5	SW1-6	SW1-7	SW1-8
191	ON	ON	ON	ON	ON	ON	OFF	ON
192	OFF	OFF	OFF	OFF	OFF	OFF	ON	ON
193	ON	OFF	OFF	OFF	OFF	OFF	ON	ON
194	OFF	ON	OFF	OFF	OFF	OFF	ON	ON
195	ON	ON	OFF	OFF	OFF	OFF	ON	ON
196	OFF	OFF	ON	OFF	OFF	OFF	ON	ON
197	ON	OFF	ON	OFF	OFF	OFF	ON	ON
198	OFF	ON	ON	OFF	OFF	OFF	ON	ON
199	ON	ON	ON	OFF	OFF	OFF	ON	ON
200	OFF	OFF	OFF	ON	OFF	OFF	ON	ON
201	ON	OFF	OFF	ON	OFF	OFF	ON	ON
202	OFF	ON	OFF	ON	OFF	OFF	ON	ON
203	ON	ON	OFF	ON	OFF	OFF	ON	ON
204	OFF	OFF	ON	ON	OFF	OFF	ON	ON
205	ON	OFF	ON	ON	OFF	OFF	ON	ON
206	OFF	ON	ON	ON	OFF	OFF	ON	ON
207	ON	ON	ON	ON	OFF	OFF	ON	ON
208	OFF	OFF	OFF	OFF	ON	OFF	ON	ON
209	ON	OFF	OFF	OFF	ON	OFF	ON	ON
210	OFF	ON	OFF	OFF	ON	OFF	ON	ON
211	ON	ON	OFF	OFF	ON	OFF	ON	ON
212	OFF	OFF	ON	OFF	ON	OFF	ON	ON
213	ON	OFF	ON	OFF	ON	OFF	ON	ON
214	OFF	ON	ON	OFF	ON	OFF	ON	ON
215	ON	ON	ON	OFF	ON	OFF	ON	ON
216	OFF	OFF	OFF	ON	ON	OFF	ON	ON
217	ON	OFF	OFF	ON	ON	OFF	ON	ON
218	OFF	ON	OFF	ON	ON	OFF	ON	ON
219	ON	ON	OFF	ON	ON	OFF	ON	ON
220	OFF	OFF	ON	ON	ON	OFF	ON	ON
221	ON	OFF	ON	ON	ON	OFF	ON	ON
222	OFF	ON	ON	ON	ON	OFF	ON	ON
223	ON	ON	ON	ON	ON	OFF	ON	ON
224	OFF	OFF	OFF	OFF	OFF	ON	ON	ON
225	ON	OFF	OFF	OFF	OFF	ON	ON	ON
226	OFF	ON	OFF	OFF	OFF	ON	ON	ON
227	ON	ON	OFF	OFF	OFF	ON	ON	ON
228	OFF	OFF	ON	OFF	OFF	ON	ON	ON
229	ON	OFF	ON	OFF	OFF	ON	ON	ON
230	OFF	ON	ON	OFF	OFF	ON	ON	ON
231	ON	ON	ON	OFF	OFF	ON	ON	ON
232	OFF	OFF	OFF	ON	OFF	ON	ON	ON
233	ON	OFF	OFF	ON	OFF	ON	ON	ON
234	OFF	ON	OFF	ON	OFF	ON	ON	ON
235	ON	ON	OFF	ON	OFF	ON	ON	ON
236	OFF	OFF	ON	ON	OFF	ON	ON	ON
237	ON	OFF	ON	ON	OFF	ON	ON	ON
238	OFF	ON	ON	ON	OFF	ON	ON	ON

*(Continued on next page)*

**Table B. D Protocol Receiver Address (Continued)**

ADDRESS	SWITCH SETTING							
	SW1-1	SW1-2	SW1-3	SW1-4	SW1-5	SW1-6	SW1-7	SW1-8
239	ON	ON	ON	ON	OFF	ON	ON	ON
240	OFF	OFF	OFF	OFF	ON	ON	ON	ON
241	ON	OFF	OFF	OFF	ON	ON	ON	ON
242	OFF	ON	OFF	OFF	ON	ON	ON	ON
243	ON	ON	OFF	OFF	ON	ON	ON	ON
244	OFF	OFF	ON	OFF	ON	ON	ON	ON
245	ON	OFF	ON	OFF	ON	ON	ON	ON
246	OFF	ON	ON	OFF	ON	ON	ON	ON

ADDRESS	SWITCH SETTING							
	SW1-1	SW1-2	SW1-3	SW1-4	SW1-5	SW1-6	SW1-7	SW1-8
247	ON	ON	ON	OFF	ON	ON	ON	ON
248	OFF	OFF	OFF	ON	ON	ON	ON	ON
249	ON	OFF	OFF	ON	ON	ON	ON	ON
250	OFF	ON	OFF	ON	ON	ON	ON	ON
251	ON	ON	OFF	ON	ON	ON	ON	ON
252	OFF	OFF	ON	ON	ON	ON	ON	ON
253	ON	OFF	ON	ON	ON	ON	ON	ON
254	OFF	ON	ON	ON	ON	ON	ON	ON

# Specifications

## ELECTRICAL

Input Voltage	24 VAC or 100-240 VAC
Input Voltage Range	±10%
Power Consumption	Maximum 60 watts (120 VA) per system
Electrical Connections	6-foot wire harness with connections for power, video, data control, alarm inputs, and auxiliary outputs

## MECHANICAL

Cable Entry	One 0.75-inch (1.91 cm) NPT threaded opening
Pan Movement	360° continuous pan rotation
Vertical Tilt	Unobstructed +90° to -90°
Variable Pan/Tilt Speed	
Pan	0.1° to 40°/sec variable-speed operation
Tilt	0.1° to 40°/sec variable-speed operation
Preset Speeds	
Pan	40°/sec
Tilt	40°/sec

## GENERAL

Construction	316L stainless steel
Finish	Electropolish
Viewing Window	0.50-inch (12.7 mm) thick, soda-lime tempered glass
Operating Temperature	-60°C to 60°C
Unit Weight	55 lb (25 kg)
Effective Projected Area (EPA)	196.1 square inches

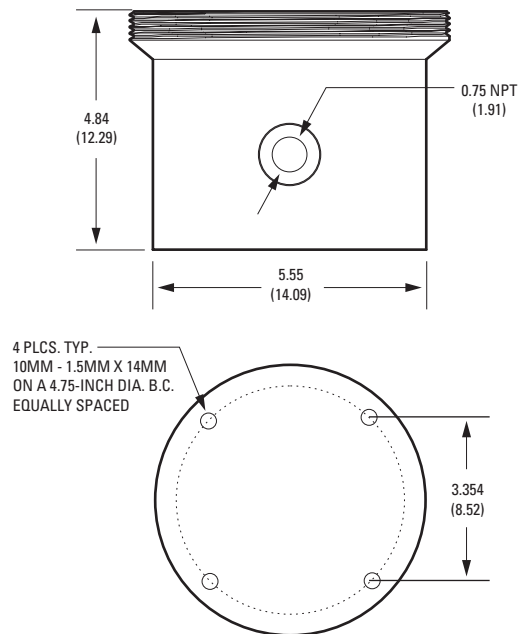

NOTE: VALUES IN PARENTHESES ARE CENTIMETERS;  
ALL OTHERS ARE INCHES.



## PRODUCT WARRANTY AND RETURN INFORMATION

### WARRANTY

Pelco will repair or replace, without charge, any merchandise proved defective in material or workmanship **for a period of one year** after the date of shipment.

Exceptions to this warranty are as noted below:

- Five years on FT/FR8000 Series fiber optic products.
- Three years on Genex® Series products (multiplexers, server, and keyboard).
- Three years on Camclosure® and fixed camera models, except the CC3701H-2, CC3701H-2X, CC3751H-2, CC3651H-2X, MC3651H-2, and MC3651H-2X camera models, which have a five-year warranty.
- Two years on standard motorized or fixed focal length lenses.
- Two years on Legacy®, CM6700/CM6800/CM9700 Series matrix, and DF5/DF8 Series fixed dome products.
- Two years on Spectra®, Esprit®, ExSite™, and PS20 scanners, including when used in continuous motion applications.
- Two years on Esprit® and WW5700 Series window wiper (excluding wiper blades).
- Eighteen months on DX Series digital video recorders, NVR300 Series network video recorders, and Endura™ Series distributed network-based video products.
- One year (except video heads) on video cassette recorders (VCRs). Video heads will be covered for a period of six months.
- Six months on all pan and tilts, scanners or preset lenses used in continuous motion applications (that is, preset scan, tour and auto scan modes).

Pelco will warrant all replacement parts and repairs for 90 days from the date of Pelco shipment. All goods requiring warranty repair shall be sent freight prepaid to Pelco, Clovis, California. Repairs made necessary by reason of misuse, alteration, normal wear, or accident are not covered under this warranty.

Pelco assumes no risk and shall be subject to no liability for damages or loss resulting from the specific use or application made of the Products. Pelco's liability for any claim, whether based on breach of contract, negligence, infringement of any rights of any party or product liability, relating to the Products shall not exceed the price paid by the Dealer to Pelco for such Products. In no event will Pelco be liable for any special, incidental or consequential damages (including loss of use, loss of profit and claims of third parties) however caused, whether by the negligence of Pelco or otherwise.

The above warranty provides the Dealer with specific legal rights. The Dealer may also have additional rights, which are subject to variation from state to state.

If a warranty repair is required, the Dealer must contact Pelco at (800) 289-9100 or (559) 292-1981 to obtain a Repair Authorization number (RA), and provide the following information:

1. Model and serial number
2. Date of shipment, P.O. number, Sales Order number, or Pelco invoice number
3. Details of the defect or problem

If there is a dispute regarding the warranty of a product which does not fall under the warranty conditions stated above, please include a written explanation with the product when returned.

Method of return shipment shall be the same or equal to the method by which the item was received by Pelco.

### RETURNS

In order to expedite parts returned to the factory for repair or credit, please call the factory at (800) 289-9100 or (559) 292-1981 to obtain an authorization number (CA number if returned for credit, and RA number if returned for repair).

All merchandise returned for credit may be subject to a 20% restocking and refurbishing charge.

Goods returned for repair or credit should be clearly identified with the assigned CA or RA number and freight should be prepaid. Ship to the appropriate address below.

*If you are located within the continental U.S., Alaska, Hawaii or Puerto Rico, send goods to:*

Service Department  
Pelco  
3500 Pelco Way  
Clovis, CA 93612-5699

*If you are located outside the continental U.S., Alaska, Hawaii or Puerto Rico and are instructed to return goods to the USA, you may do one of the following:*

If the goods are to be sent by a COURIER SERVICE, send the goods to:

Pelco  
3500 Pelco Way  
Clovis, CA 93612-5699 USA

If the goods are to be sent by a FREIGHT FORWARDER, send the goods to:

Pelco c/o Expeditors  
473 Eccles Avenue  
South San Francisco, CA 94080 USA  
Phone: 650-737-1700  
Fax: 650-737-0933



This equipment contains electrical or electronic components that must be recycled properly to comply with Directive 2002/96/EC of the European Union regarding the disposal of waste electrical and electronic equipment (WEEE). Contact your local dealer for procedures for recycling this equipment.

### REVISION HISTORY

Manual #	Date	Comments
C313M	11/04	Original version.
C313M-A	1/05	Added 24 VAC power supply information per ECO 04-10256.
C313M-B	4/05	Wire color change for Alarm COM per ECO 05-11019.
C313M-C	5/05	Added warning to provide access to communication wires.
C313M-D	8/05	Revised dimension drawing per ECO 05-11303.



Worldwide Headquarters  
3500 Pelco Way  
Clovis, California 93612 USA

USA & Canada  
Tel: 800/289-9100  
Fax: 800/289-9150

International  
Tel: 1-559/292-1981  
Fax: 1-559/348-1120

**[www.pelco.com](http://www.pelco.com)**

**ISO9001**

United States | Canada | United Kingdom | The Netherlands | Singapore | Spain | Scandinavia | France | Middle East