



MANUAL PART NUMBER: 400-0039-003
PRODUCT REVISION: 1

VA6834FC

SYSTEM ANALOG INTERFACE

USER'S GUIDE

INTRODUCTION

Altinex appreciates your purchase of the **VA6834FC** Analog Interface. We are sure you will find it to be reliable and simple to use.

Superior performance for the right price, backed by solid technical and customer support is what Altinex has to offer.

The product you are holding in your hands is designed using state-of-the-art technology and is superior to anything available on the market. You will find this and our other products reliable, long lasting, and simple to operate.

We are committed to providing our customers with signal management solutions to the most demanding audio-visual installations at very competitive pricing.

We appreciate your selection of our products and are confident that you will join the ranks of our many satisfied customers throughout the world.

This manual covers:

- VA6834FC** VGA – Pack
- VA6834FC** MAC – Pack
- VA6834FC** SUN/SGI – Pack
- VA6834FC** RGB – Pack
- VA6834FC** Combo – Pack
- VA6834FC** Super – Pack

TABLE OF CONTENTS

	Page
PRECAUTIONS / SAFETY WARNINGS	2
GENERAL	2
RACK MOUNT SAFETY GUIDELINES	2
CLEANING	2
FCC / CE NOTICE	2
ABOUT YOUR INTERFACE	3
TECHNICAL SPECIFICATION	3
VA6834FC DESCRIPTION	4
COMPUTER VIDEO INPUT (VGA-COMPATIBLE 15-PIN HD CONNECTOR)	4
LOCAL MONITOR OUTPUT (15-PIN HD CONNECTOR)	4
MAIN (RGBS/RGBHV) OUTPUTS THROUGH 6 BNC CONNECTORS	4
HORIZONTAL POSITION ADJUSTMENT	7
HORIZONTAL DELAY REMOVAL	7
POWER REQUIREMENTS	7
MOUNTING CAPABILITY	7
BANDWIDTH	7
APPLICATION DIAGRAM	8
INSTALLING YOUR INTERFACE	8
OPERATION	9
SERRATION PULSE SWITCH	9
H&V OUT SWITCH	9
I.D. BIT SWITCH	9
SYNC ON GREEN OUTPUT SWITCH	9
TERMINATION SWITCH	9
ACCESSORIES	10
FAQ (FREQUENTLY ASKED QUESTIONS)	11
TROUBLESHOOTING GUIDE	12
ALTINEX POLICY	13
LIMITED WARRANTY	13
RETURN POLICY	13
CONTACT INFORMATION	13

PRECAUTIONS / SAFETY WARNINGS 1

Please read this manual carefully before using your **VA6834FC** Interface. Keep this manual handy for future reference. These safety instructions are to ensure the long life of your **VA6834FC** and to prevent fire and shock hazard. Please read them carefully and heed all warnings.

1.1 GENERAL

- Unauthorized personnel shall not open the unit since there are high-voltage components inside.
- Qualified Altinex service personnel, or their authorized representatives must perform all service.

1.2. SAFETY GUIDELINES FOR THE RACK-MOUNTING OF THE VA6834FC

- Maximum operating ambient temperature is 35 (degrees C).
- Never restrict the airflow through the devices' fan or vents.
- When installing equipment into a rack, distribute the units evenly. Otherwise, hazardous conditions may be created by an uneven weight distribution.
- Connect the unit to a properly rated supply circuit.
- Reliable Earthing (Grounding) of Rack-Mounted Equipment should be maintained.

1.3 INSTALLATION

- For best results, place the **VA6834FC** Interface on a flat, level surface in a dry area away from dust and moisture.
- To prevent fire or shock, do not expose this unit to rain or moisture. Do not place the **VA6834FC** Interface in direct sunlight, near heaters or heat radiating appliances, or near any liquid. Exposure to direct sunlight, smoke, or steam can harm internal components.
- Handle the **VA6834FC** Interface carefully because dropping or jarring can damage internal components.
- Do not place heavy objects on top of the **VA6834FC**. If the **VA6834FC** is to be mounted

to a table or wall, use only Altinex made mounting accessories, such as brackets (**DA1293FC** or **DA1294FC**) and cables for optimum setup.

- To turn off the main power, be sure to remove the power cord from the power outlet. The power outlet socket should be installed as near to the equipment as possible, and should be easily accessible.
- Do not pull the power cord or any cable that is attached to the **VA6834FC** Interface.
- If the **VA6834FC** Interface is not used for an extended period, disconnect the power cord from the power outlet.

1.4 CLEANING

- Unplug the **VA6834FC** power cord before cleaning. Clean surfaces with a dry cloth. Never use strong detergents or solvents, such as alcohol or thinner. Do not use a wet cloth or water to clean the unit.

1.5 FCC / CE NOTICE

- This device complies with Part 15 of the FCC Rules. Operation is subject to the following two conditions: (1) This device may not cause harmful interference, and (2) this device must accept any interference received, including interference that may cause undesired operation.
- This equipment has been tested and found to comply with the limits for a Class A digital device, pursuant to Part 15 of the FCC Rules. These limits are designed to provide reasonable protection against harmful interference when the equipment is operated in a commercial environment. This equipment generates, uses, and can radiate radio frequency energy and, if not installed and used in accordance with the instruction manual, may cause harmful interference to radio communications. Operation of this equipment in a residential area is likely to cause harmful interference in which case the user will be required to correct the interference at his own expense.

- Any changes or modifications to the unit not expressly approved by Altinex, Inc. could void the user's authority to operate the equipment.

ABOUT YOUR INTERFACE 2

There are many types of computers and computer video cards on the market today. There are also numerous data monitors and large screen data projectors. When a computer image is displayed on a large screen data projector or on a large screen monitor, it often becomes clear that some computers are not always compatible with certain display devices. The **VA6834FC** is a computer video interface designed to resolve this incompatibility.

The **VA6834FC** is a dual output computer video interface. It is designed to interface a single VGA/SVGA/XGA/UXGA/MAC/SUN or SGI computer video source to two scan-rate compatible presentation monitors or data projectors.

It is important to understand the general capabilities of interfaces. Interfaces do not change the scan-rate or the resolution of the video signal. An interface simply converts a computer video signal to a pre-selected analog format.

The **VA6834FC** is a state-of-the art piece of equipment with an exceptional combination of compact size, advanced features and very competitive pricing.

TECHNICAL SPECIFICATIONS 3

FEATURES/DESCRIPTION	VA6834FC
GENERAL	
Inputs	1
Computer Video Input Connector	15-pin HD Female
Outputs	Local Monitor Output + 2 Main Video Outputs
Local Monitor Connector	15-pin HD Female
Main Video Connector	2 sets of 6-BNC F
Compatibility	VGA/SVGA/XGA/UXGA, Apple/MACII/Quadra/G3, Sun/SGI Workstations

Table 1. **VA6834FC** General

MECHANICAL	VA6834FC
Width (inches)	8.50in
Height (inches)	1.75in
Depth (inches)	4.93in.
Weight (pounds)	2.0lbs.
Ship Weight (pounds)	2.8lbs.
Material	0.1" Aluminum
Finish	Gray
Faceplate	Lexan
T° Operating	10°C-35°C
T° Maximum	50°C
Humidity I	90% non-condensing
MTBF (calculations)	40,000 hrs

Table 2. **VA6834FC** Mechanical

ELECTRICAL	VA6834FC
Input Video Signal	
Analog Signal	0.3 to 1.2 volt p-p
Impedance	75 Ohms
Rise/Fall Time (ns)	0.9
Input Sync Signal	
Horizontal, Vertical, & C-Sync	TTL(+/-)
Sync on Green	-0.3V
Impedance	0.3 k Ohms
Output Video Signals	
Analog Signal	0.77 V p-p
Impedance	75 Ohms
Rise/Fall Time (ns)	1.2
Output Sync Signal	
Composite Sync	TTL(+/-)
Sync on Green	-0.3V
Impedance	22 Ohms
Frequency Compatibility	
Minimum Video Bandwidth	350 MHz
Typical Video Bandwidth	425 MHz
Horizontal	15-130 kHz
Vertical	25-180 Hz
Horizontal Position Range	20 %
Cross-talk	39dB @ 100MHz
Power	
Internal Power Supply	90-140V/200-240V
Power Consumption	

Table 3. **VA6834FC** Electrical

VA6834FC DESCRIPTION 4

The **VA6834FC** has two key functions. Its first function is to buffer the signal and insure that it is strong enough to travel a distance of 100 ft or longer through a coaxial cable. The second function is to process the sync and to convert it into a format that is acceptable to most displays.

4.1 COMPUTER VIDEO INPUT (VGA-COMPATIBLE HD 15-PIN CONNECTOR).

The HD 15-pin connector input allows the connection of a computer source to the interface using Altinex input cables, which are available for a variety of popular computers and graphics cards on the market. These include VGA, MAC, SUN, and SGI type video output connectors with the proper cables. The **VA6834FC** input is compatible with standard VGA cables.

PIN No.	INPUT SIGNALS ON HD 15-PIN FEMALE CONNECTOR
1	Red Video
2	Green Video
3	Blue Video
4	ID Bit (Grounded when ID Bit switch is ON)
5	Ground
6	Ground
7	Ground
8	Ground
9	No connection
10	No connection
11	ID Bit
12	ID Bit
13	Horizontal Sync/Composite Sync
14	Vertical Sync
15	No connection

Table 4. **VA6834FC** Input pin-out

4.2 LOCAL MONITOR OUTPUT (HD 15-PIN CONNECTOR)

The HD 15-Pin connector output is used to connect the local monitor to the interface. This is a fully buffered output, eliminating reflections often caused by “Y” type monitor breakout cables. There is no need to terminate the unused output. The termination switch on the **VA6834FC** affects only the terminations of the computer video input. The output is VGA compatible, but can also be used to feed other

types of local monitors using designated Altinex adapter cables such as VGA, MAC, SUN, SGI or RGB.

PIN No.	LOCAL MONITOR OUTPUT SIGNALS ON 15-PIN HD FEMALE CONNECTOR
1	Red Video
2	Green Video
3	Blue Video
4	ID Bit (Grounded when ID Bit switch is ON)
5	Ground
6	Ground
7	Ground
8	Ground
9	Composite Sync
10	No connection
11	ID Bit
12	ID Bit
13	Horizontal Sync
14	Vertical Sync
15	No connection

Table 5. Local Monitor Output pin-out

4.3 MAIN (RGBS/RGBHV) OUTPUTS THROUGH 6 BNC CONNECTORS

BNC connectors offer a reliable connection for high-resolution video signals, and they facilitate easy cable maintenance in the field. The **VA6834FC** offers two main outputs with six BNC connectors for each output. By selecting the appropriate connectors, these outputs can provide RG_sB, RGBHV, or RGBS output signals.

For a RG_sB type signal the “Sync on Green” dip switch must be set to the ON position.

For an RGBHV type signal, you may either connect cables to horizontal or vertical BNC connectors or you may connect the horizontal channel to the composite sync connector by turning the HV OUTPUT switch to the ON position. For a RGBS type signal output, the cables should be connected to a composite sync signal. With these connectors the **VA6834FC** can be connected to compatible data projectors using 3 coax, 4 coax, or 5 coax cables.

FRONT PANEL OF VA6834FC

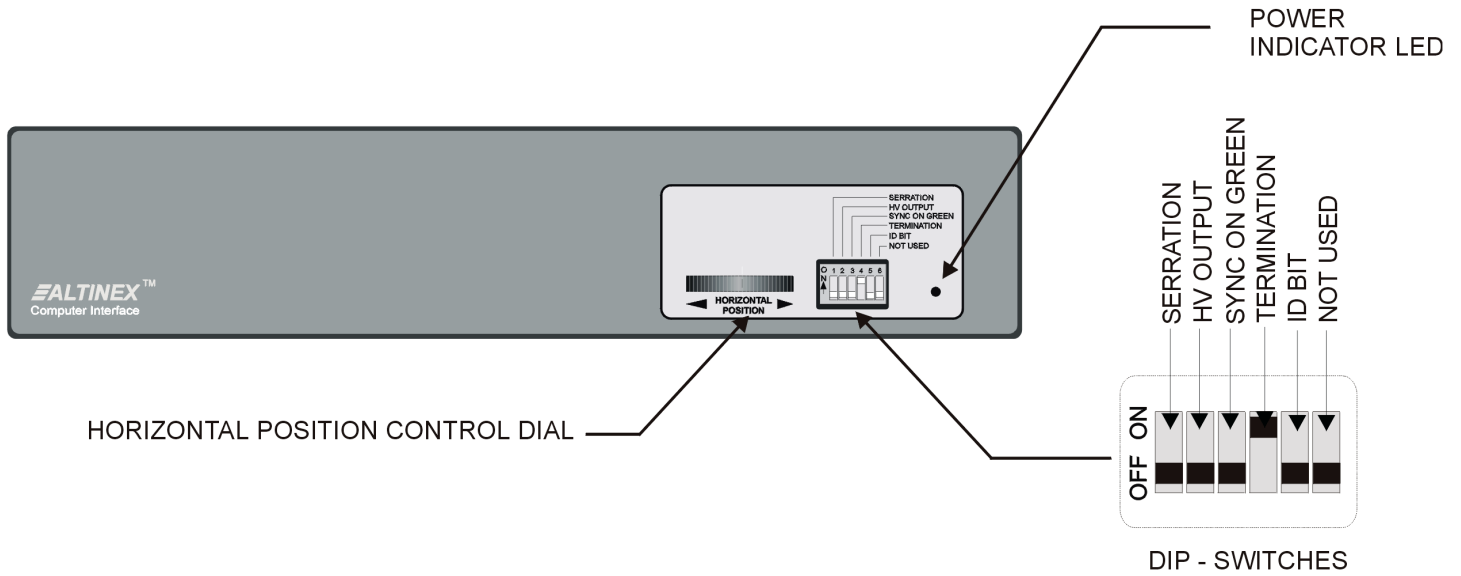

BACK PANEL OF VA6834FC

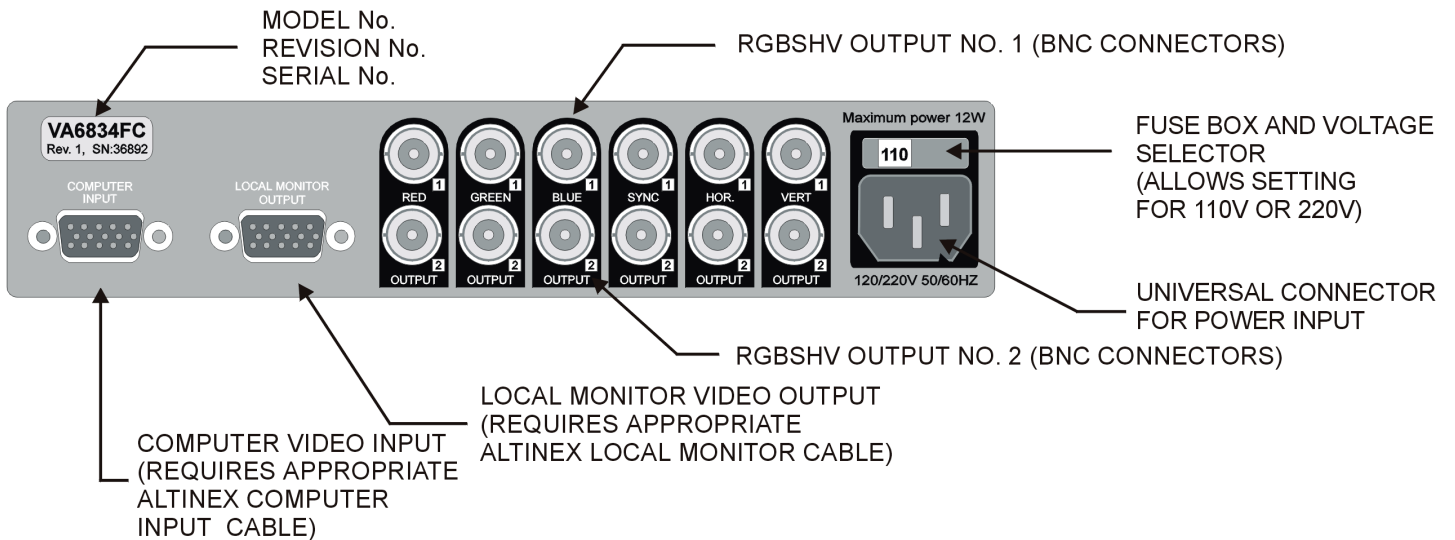

INPUT/LOCAL MONITOR CABLES

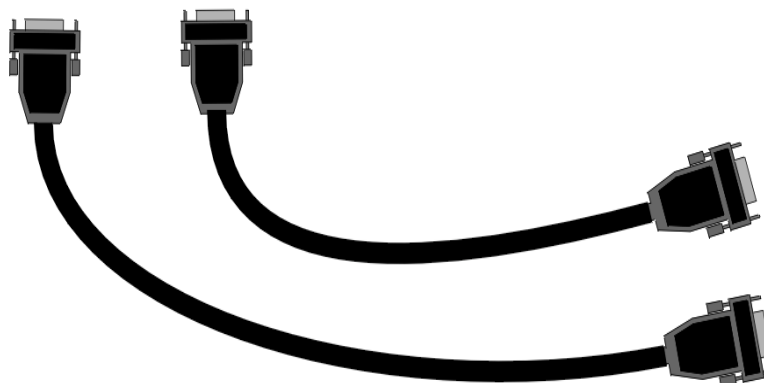
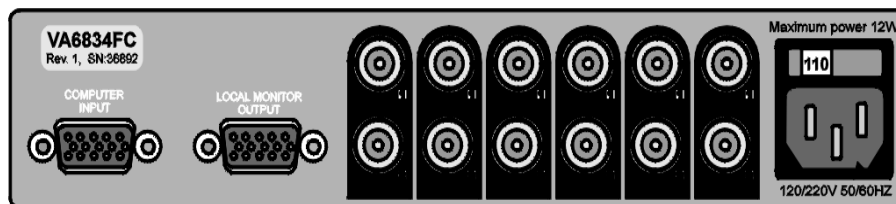

**LOCAL MONITOR CABLE
(F) to (M)**

**COMPUTER INPUT CABLE
(M) to (M)**

3 FT CABLES:

- MS8121CA - MAC Local Monitor Cable
- MS8122CA - MAC Input Cable
- MS8123CA - SUN/SGI Local Monitor Cable
- MS8124CA - SUN/SGI Input Cable
- MS8125CA - VGA Local Monitor Cable
- MS8126CA - VGA Input Cable
- MS8129CA - 5 BNC Input/Local Monitor Cable

6 FT CABLES:

- MS8151CA - MAC Local Monitor Cable
- MS8152CA - MAC Input Cable
- MS8153CA - SUN/SGI Local Monitor Cable
- MS8154CA - SUN/SGI Input Cable
- MS8155CA - VGA Local Monitor Cable
- MS8156CA - VGA Input Cable
- MS8159CA - 5 BNC Input/Local Monitor Cable

12 FT CABLES:

- MS8161CA - MAC Local Monitor Cable
- MS8162CA - MAC Input Cable
- MS8163CA - SUN/SGI Local Monitor Cable
- MS8164CA - SUN/SGI Input Cable
- MS8165CA - VGA Local Monitor Cable
- MS8166CA - VGA Input Cable
- MS8169CA - 5 BNC Input/Local Monitor Cable

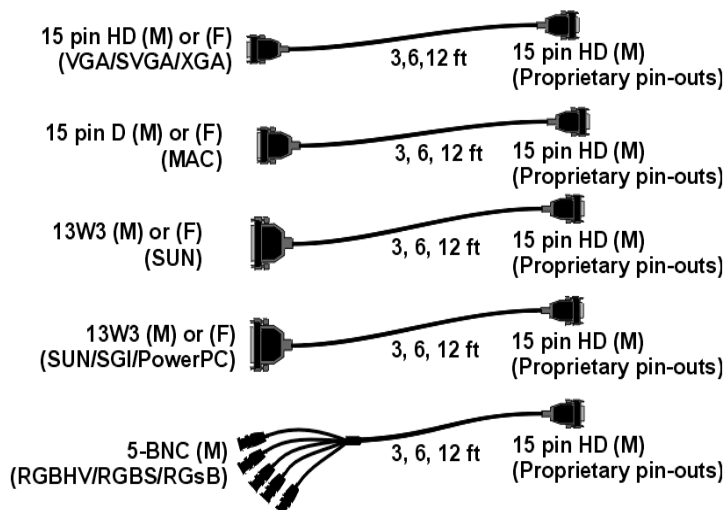

CONNECTOR	MAIN DUAL OUTPUT (6-BNC FEMALE)
Red	Red Video
Green	Green Video
Blue	Blue Video
Sync	Composite Sync/ Horizontal
Hor.	Horizontal Sync
Vert.	Vertical Sync

Table 3. **VA6834FC** dual (6 BNC) Output pin-out

4.4 HORIZONTAL POSITION ADJUSTMENT

Most monitors and projectors have the ability to adjust the horizontal position of the image, but sometimes it is helpful to be able to control this feature at the interface. This control is especially useful when multiple computers are switched to a single display and the horizontal positions from each computer are slightly different.

By keeping the **VA6834FC**'s horizontal position control dial located in the center position, the image on the display should be adjusted using the monitor or projector control. If it is necessary, adjust the horizontal position of the image with the **VA6834FC**'s horizontal position control dial.

To turn off the horizontal position control, turn the adjustment dial fully to the right until a "clicking sound is heard.

4.5 HORIZONTAL DELAY REMOVAL

The **VA6834FC** offers the ability to by-pass horizontal delay. This may be necessary when interfacing with projectors or monitors with sensitive sync inputs, particularly with LCD type projectors. By turning the horizontal position adjustment dial fully to the right, the control will "click" into a locked position. In this position, the **VA6834FC** outputs the same sync type as that which is fed into it from the source. In this setting, the **VA6834FC** will not provide horizontal positioning. Horizontal position adjustment must be made at the display.

4.6 POWER REQUIREMENTS

The **VA6834FC** may be used with either 120V or 220V throughout the world for ease of use. Always make sure that the fuse box window above the power input connector displays the proper voltage. To change the setting, unplug the **VA6834FC**, and squeeze the clips on either side of the fuse box. Pull out the fuse holder and turn it 180 degrees, resetting it with the proper voltage shown through the window. Re-insert the fuse box making sure that the side clips of the fuse box lock securely into place.

4.7 MOUNTING CAPABILITY

The **VA6834FC** can be easily mounted into an equipment rack. Four mounting holes are provided on each side of the unit. To mount a single unit, use Altinex 19"-1U Rack Mount Ears (part # **DA1294FC**). To mount two units in tandem, use an Altinex 19"-1U Rack Mount Shelf (part # **DA1293FC**). For mounts under the table, optional brackets, such as the **TM1271**, **TM1272**, **TM1273**, or **TM1274** can be used.

4.8 BANDWIDTH

The typical bandwidth of the **VA6834FC** is 425 MHz. The minimum bandwidth is 350 MHz. This exceptionally high bandwidth allows the passing of the third harmonics of the video signal, thus maintaining the highest quality of the input signal.

APPLICATION DIAGRAM 5

COMPUTER SOURCE

INTERFACE

VIDEO DISPLAY

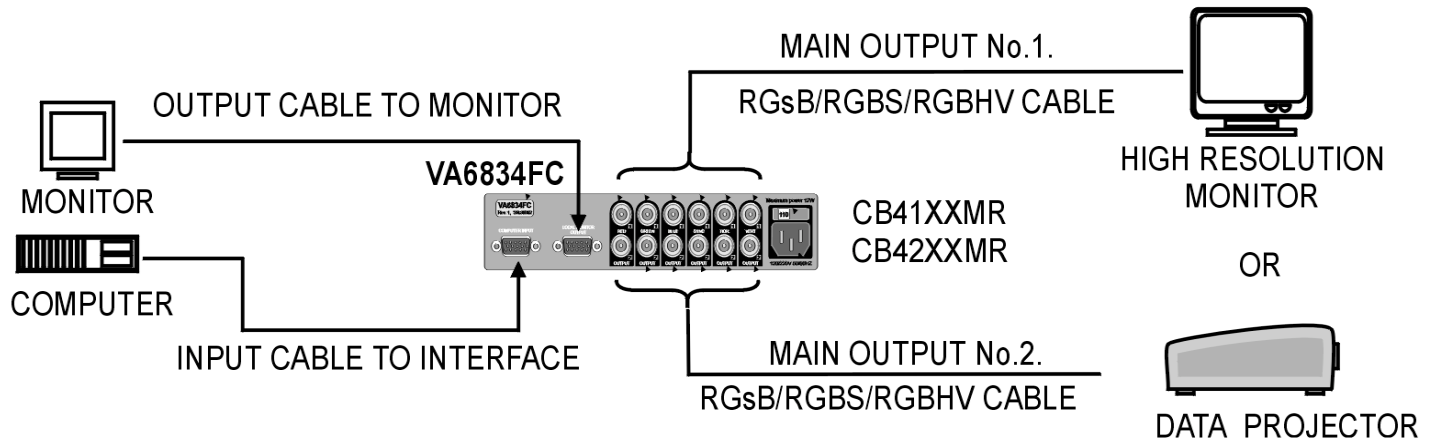

INSTALLING YOUR INTERFACE 6

- Step 1.** Please attach the Interface on the rack using the provided rack mount hardware. The Interface can also be attached on top or under furniture using the optional **TM** Series Altinex brackets.
- Step 2.** Before you plug in the power cord to the unit, please verify that the voltage rating of 110V/220V which is located on the FUSE CLIP at the rear of the unit is the same as the power outlet. (Refer to section 4-6 for changing voltage)
- Step 3.** Connect one end of the input cable included with the Interface unit to the video output connector of your computer and other end to the computer input HD-15 port of the **VA6834FC**.
- Step 4.** If needed, connect the local monitor output HD-15 connector of the **VA6834FC** to the local monitor using the appropriate Altinex Local Monitor cables. It is not necessary to terminate this output with a termination plug if a local monitor is not being used.

- Step 5.** Connect one end of a BNC cable to output 1 or 2 of the **VA6834FC**. Connect the other end to the RGB input on the projector or monitor. Usually either a 4 BNC or 5 BNC coaxial cable is used, depending on whether display devices require Composite SYNC or H&V SYNC signals.
- Step 6.** Make sure that the dip-switches are set properly. For the desired sync output format, refer to section 7.
- Step 7.** It is recommended that if the Interface horizontal position control is centered (turned OFF), the horizontal position of the image should be adjusted using the control provided by the monitor or projector. If still required, the image can be adjusted using the horizontal position control dial located on the front of the **VA6834FC**.

CONGRATULATIONS! YOU ARE DONE.

If you experience any problems, please call
1-800-258-4623 or 1-714-990-2300 for
international calls.

OPERATION 7

The settings of the **VA6834FC** Interface can be adjusted using the dip-switches in Table 4. There are no other adjustments necessary to operate the unit. The **VA6834FC** will operate successfully as long as cables are attached properly and technical specifications are followed.

DIP SWITCH	OFF	ON
Serration	X	
HV Output	X	
Sync on Green	X	
Termination		X
ID Bit	X	
Not Used	X	

Table 6. Dip switches default setting

7.1 SERRATION PULSE SWITCH

Certain monitors and projectors will exhibit better stability when the serration pulse switch is ON. This switch is seldom used and in most circumstances should be turned OFF.

7.2 H&V OUT SWITCH

When the composite sync channel is used and RGBS format is desired from the **VA6834FC**, the H & V OUT switch should be turned off. When this switch is turned on, the sync. The connector will output horizontal sync, but not composite sync. The horizontal sync can be connected to the sync connector and the vertical sync signal is connected to the vertical connector using the H & V OUT switch in the ON position.

7.3 I.D. BIT SWITCH

Many computers use ID Bits or Sense Pins to recognize the connection of a monitor to its video output port. Often, these ID Bits will even allow the computer to recognize the type of monitor connected in terms of its scan rate compatibility. When the I.D. Bit switch is in the ON position, the **VA6834FC** allows the main ID Bit (pin 4 on the input connector) to be connected to the ground signal. This is used primarily when interfacing to laptop computers to imitate the presence of a local monitor. Typically, this recognition will take place during

the boot up stage of the computer. If your computer does not output video, place the I.D. Bit switch in the ON position and reboot the computer. When in the OFF position, the ID Bit will be passed through the Local Monitor Output port.

7.4 SYNC ON GREEN OUTPUT SWITCH

In some systems the ability of the **VA6834FC** to output Sync on Green can be a very helpful feature. It is important to know that the **VA6834FC** will not separate the sync signal from the green signal if the input is RGsB. It simply amplifies the composite sync signal and passes it through. The **VA6834FC** will combine the sync signal and the green channel to output a RGsB signal when the SYNC ON GREEN dip-switch is in the ON position even if the input is in RGBS or RGBHV format. If the desired output is RGBS or RGBHV, then leave the SYNC ON GREEN dipswitch in the OFF position.

7.5 TERMINATION SWITCH

When the built-in termination switch is set to the ON position, the input of the interface will be terminated. As a rule, the termination switch should be ON. This switch does not affect the termination of any output signal. The termination switch should be left in the OFF position if a "Y" cable is used at the local monitor output connector.

ACCESSORIES 8

Model No.	Description
RACK MOUNT ACCESSORIES	
DA1293SX	Rack/Wall Shelf fits two VA6834FC units side by side
DA1294SX	Rack/Wall mount ears for single VA6834FC
TABLE MOUNT BRACKETS	
TM1271	1U High, ½ Rack-Wide
TM1272	1U High, ½ Rack-Wide with 15-pin HD connector plate
TM1273	1U High, ½ Rack-Wide with snap-in connectors
Model No.	Description
TM1274	1U High, ½ Rack-Wide with snap-in & POWER connectors
INTERFACE CABLES	
MS8121CA	MAC Output cable for VA6834FC
MS8122CA	MAC Input cable for VA6834FC
MS8123CA	SUN/SGI Output cable for VA6834FC
MS8124CA	SUN/SGI Input cable for VA6834FC
MS8125CA	VGA Output cable for VA6834FC
MS8126CA	VGA Input cable for VA6834FC
MS8129CA	RGB Output cable for VA6834FC
4-BNC TO 4-BNC COAXIAL CABLE	
CB4103MR	3 ft, 4-BNC to 4-BNC coaxial cable
CB4106MR	6 ft, 4-BNC to 4-BNC coaxial cable
CB4112MR	12 ft, 4-BNC to 4-BNC coaxial cable
CB4125MR	25 ft, 4-BNC to 4-BNC coaxial cable
CB4150MR	50 ft, 4-BNC to 4-BNC coaxial cable
CB4175MR	75 ft, 4-BNC to 4-BNC coaxial cable
CB41100MR	100 ft, 4-BNC to 4-BNC coaxial cable
CB41150MR	150 ft, 4-BNC to 4-BNC coaxial cable
5-BNC TO 5-BNC COAXIAL CABLE	
CB4203MR	3 ft, 5-BNC to 5-BNC coaxial cable
CB4206MR	6 ft, 5-BNC to 5-BNC coaxial cable
CB4212MR	12 ft, 5-BNC to 5-BNC coaxial cable
CB4225MR	25 ft, 5-BNC to 5-BNC coaxial cable
CB4250MR	50 ft, 5-BNC to 5-BNC coaxial cable
CB4275MR	75 ft, 5-BNC to 5-BNC coaxial cable

CB42100MR	100 ft, 5-BNC to 5-BNC coaxial cable
CB42150MR	150 ft, 5-BNC to 5-BNC coaxial cable
CB4400MR	
CB4406MR	6 ft, 5-BNC to 5-BNC coaxial
CB4412MR	12 ft, 5-BNC to 5-BNC coaxial
CB4425MR	25 ft, 5-BNC to 5-BNC coaxial
	50 ft, 5-BNC to 5-BNC coaxial
CB4475MR	75 ft, 5-BNC to 5-BNC coaxial
CB44100MR	100 ft, 5-BNC to 5-BNC coaxial
CB44150MR	150 ft, 5-BNC to 5-BNC coaxial
CB5000PL	
CB5000PL-5BM00035BM	3 ft, 5-BNC M to 5-BNC M
CB5000PL-5BM00065BM	6 ft, 5-BNC M to 5-BNC M
CB5000PL-5BM00125BM	12 ft, 5-BNC M to 5-BNC M
CB5000PL-5BM00255BM	25 ft, 5-BNC M to 5-BNC M
CB5000PL-5BM00505BM	50 ft, 5-BNC M to 5-BNC M
CB5000PL-5BM00755BM	75 ft, 5-BNC M to 5-BNC M
CB5000PL-5BM01005BM	100 ft, 5-BNC M to 5-BNC M
CB5000PL-5BM01505BM	150 ft, 5-BNC M to 5-BNC M
CB5000PL-5BM02005BM	200 ft, 5-BNC M to 5-BNC M
CB5000PL-5BM02505BM	250 ft, 5-BNC M to 5-BNC M
CB5100PL	
CB5100PL-5BM00035BM	3 ft, 5-BNC M to 5-BNC M
CB5100PL-5BM00065BM	6 ft, 5-BNC M to 5-BNC M
CB5100PL-5BM00125BM	12 ft, 5-BNC M to 5-BNC M
CB5100PL-5BM00255BM	25 ft, 5-BNC M to 5-BNC M
CB5100PL-5BM00505BM	50 ft, 5-BNC M to 5-BNC M
CB5100PL-5BM00755BM	75 ft, 5-BNC M to 5-BNC M

CB5100PL-5BM01005BM	100 ft, 5-BNC M to 5-BNC M
CB5100PL-5BM01505BM	150 ft, 5-BNC M to 5-BNC M
CB5100PL-5BM02005BM	200 ft, 5-BNC M to 5-BNC M
CB5100PL-5BM02505BM	250 ft, 5-BNC M to 5-BNC M

All **MS81** series cables listed on the previous page are 3 ft. long. These are available in 6 ft. and 12 ft. lengths. Please call 1-714-990-2300 for a wider selection of cables.

FAQ (FREQUENTLY ASKED QUESTIONS) 9

No:	Question	Answer
1	Why does the termination switch have to be ON?	The termination switch should be ON if a local monitor is connected through a straight cable. It will be OFF only if a monitor breakout cable is used at the local monitor output connector.
2	When and why should I use the Horizontal Position Control dial?	The Horizontal Position Control dial enables or disables the control of the horizontal position of the image. First, adjust the horizontal position using the monitor or projector's control. Then use the horizontal Position Control of the VA6834FC , if needed.
3	What dip-switch do I set to obtain composite SYNC output?	If the desired output signal is composite sync, then turn OFF the H & V OUTPUT Dip-switch and connect only 4 wires (RGSB) to the red, green, blue and sync connectors.
4	When and why would I use the sync on green dip-switch, although the unit does not	The VA6834FC does not separate the sync signal from green. If the desired output is in RGSB format, turn the sync on green dip-switch to the ON position. The VA6834FC combines sync on green if the dip-switch is in the ON position.

	separate sync from green?	
5	When do I use the H & V OUT dip-switch?	If the desired output is in RGBHV format, turn ON the H & V OUT dip-switch. If the H & V OUT dip-switch is OFF, then the output signal may have composite sync present on the horizontal sync connector.
6	What is a Common Computer Video Card pin-out?	See table 5 for pin-outs for common computer video cards that can be used with the VA6834FC .

PIN No.	MAC	VGA	SUN
A1	n/a	n/a	Red
A2	n/a	n/a	Green
A3	n/a	n/a	Blue
1	Red Gnd	Red	N/C
2	Red	Green	N/C
3	C.Sync	Blue	Sense
4	ID Bit 01	ID Bit	Sense Rtn
5	Green	N/C	C. Sync Sens
6	Green Gnd.	Red Rtn.	N/C
7	ID Bit 02	Green Rtn.	N/C
8	N/C	Blue Rtn.	N/C
9	Blue	N/C	N/C
10	ID Bit 03	Gnd	N/C
11	C/V Gnd.	ID Bit	
12	V. Sync	ID Bit	
13	Blue Gnd.	H. Sync.	
14	H. Gnd	V. Sync	
15	H. Sync	N/C	

Table 7. Common Computer Video Cards pin-out.

TROUBLESHOOTING GUIDE 10

1. The power, LED should be ON when the correct voltage is applied to Interface.
2. The Termination dipswitch should be in the ON position if no Y cable (breakout) is used on the input.
3. Make sure that the cables have the correct pin-outs and the connection and quality of the cables are good.
4. Make sure that the source and display are scan-rate compatible. The projector should support an appropriate signal format (RGsB, RGSB or RGBHV). Connect the projector directly to a computer with a shorter cable to verify the compatibility of the display and the source.
5. If you are using output RGSB or RGsB then the HV Output dip-switch is in the OFF position and the composite sync signal is taken from the sync connector. If the display needs an RGBHV signal then the HV Output dip-switch should be ON if sync and vertical connectors are used.
6. If the desired output is RGsB then the Sync on Green dipswitch should be ON.

11.1 LIMITED WARRANTY

Altinex warrants that its products and cables are free from defects in materials under normal use and service. This warranty is limited to repairing at company's factory any part or parts of the product, which upon company's examination shall disclose to be, thus defective. Products considered defective should be returned to company with transportation charges pre-paid within 2 years (90 days for cables) from date of shipment to the purchaser. The warranty is expressly instead of all other warranties expressed or implied. Altinex neither assumes nor authorizes any other person to assume for it any other liability in connection with the sale of the products. This warranty shall not apply to any product that shall have been repaired or altered outside of company's factory in any way so as, in its judgment, to affect its stability or reliability, or that has been subject to misuse, negligence or accident.

11.2 RETURN POLICY

It is very important to Altinex that you receive the product that you have ordered and that this product fulfills your need. In the unlikely event, that an Altinex product needs to be returned please follow the policies below:

Altinex will accept product returns for a period of 30 days from authorized Altinex dealers. Products must be returned in an unopened package.

If a product has been opened, the restocking fees will apply. For the restocking fee amount, please contact an Altinex Sales Representative.

If the product is in your possession for more than 30 days, the restocking fees will apply.

Altinex will not accept any returns on cables or custom products.

If your product is in warranty and needs service, contact the Altinex Sales Department for an RMA (Return Material Authorization). Products returned without an RMA number may experience a delay in service.

If your product is out of warranty and needs service, contact the Altinex Sales Department for an RMA (Return Material Authorization). Products returned without an RMA number may experience a delay in service. The service charges will be quoted to you before the actual repairs are done.

11.3 CONTACT INFORMATION

Sales Department

Phone: 714-990-2300

Fax: 714-990-3303

Accounting Department

Phone: 714-990-6088

Fax: 714-990-5778