

Models P57 & P57-0011

Triplex Ceramic
Plunger Pump
Operating Instructions/
Repair and Service
Manual

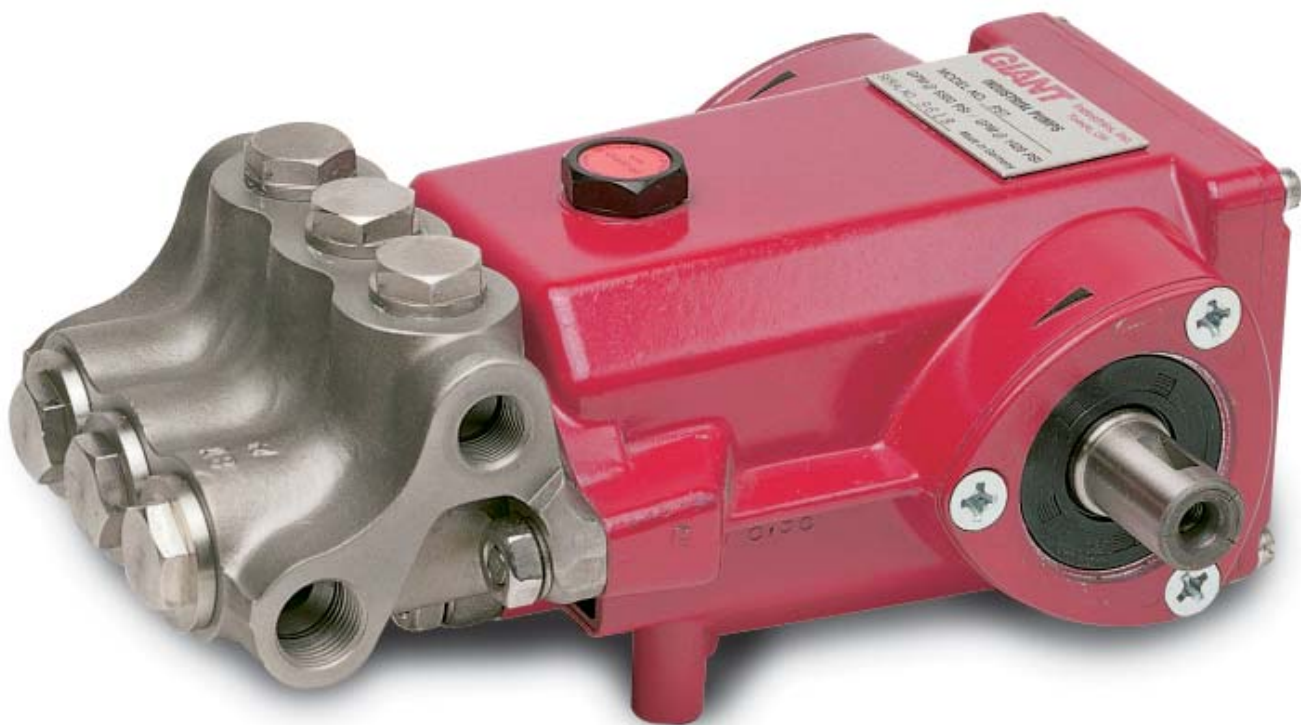

Updated 7/07

Contents:

Installation Instructions:	page 2
Pump Specifications:	page 3
Exploded View:	page 4
Parts List / Kits:	page 5
Torque Specifications:	page 5
Trouble Shooting:	page 6
Pump Mounting Selection Guide:	page 6
Recommended Maintenance Schedule:	page 6
Repair Instructions:	page 7
Dimensions:	back page
Warranty Information:	back page

INSTALLATION INSTRUCTIONS

Installation of the Giant Industries, Inc., pump is not a complicated procedure, but there are some basic steps common to all pumps. The following information is to be considered as a general outline for installation. If you have unique requirements, please contact Giant Industries, Inc. or your local distributor for assistance.

1. The pump should be installed flat on a base to a maximum of a 15 degree angle of inclination to ensure optimum lubrication.
2. The inlet to the pump should be sized for the flow rate of the pump with no unnecessary restrictions that can cause cavitation. Teflon tape should be used to seal all joints. If pumps are to be operated at temperatures in excess of 160° F, it is important to insure a positive head to the pump to prevent cavitation.
3. The discharge plumbing from the pump should be properly sized to the flow rate to prevent line pressure loss to the work area. It is essential to provide a safety bypass valve between the pump and the work area to protect the pump from pressure spikes in the event of a blockage or the use of a shut-off gun.

4. Use of a dampener is necessary to minimize pulsation at drive elements, plumbing, connections, and other system areas. The use of a dampener with Giant Industries, Inc. pumps is optional, although recommended by Giant Industries, Inc. to further reduce system pulsation. Dampeners can also reduce the severity of pressure spikes that occur in systems using a shut-off gun. A dampener must be positioned downstream from the unloader.

5. Crankshaft rotation on Giant Industries, Inc. pumps should be made in the direction designated by the arrows on the pump crankcase. Reverse rotation may be safely achieved by following a few guidelines available upon request from Giant Industries, Inc. Required horsepower for system operation can be obtained from the chart on page 3.

6. Before beginning operation of your pumping system, remember: Check that the crankcase and seal areas have been properly lubricated per recommended schedules. Do not run the pump dry for extended periods of time. Cavitation will result in severe damage. Always remember to check that all plumbing valves are open and that pumped media can flow freely to the inlet of the pump.

Finally, remember that high pressure operation in a pump system has many advantages. But, if it is used carelessly and without regard to its potential hazard, it can cause serious injury.

IMPORTANT OPERATING CONDITIONS

Failure to comply with any of these conditions invalidates the warranty.

1. Prior to initial operation, add oil to the crankcase so that oil level is between the two lines on the oil dipstick. **DO NOT OVERFILL.**

Use Giant 20W-50 oil (p/n 01153) or use SAE 80-90W Industrial Gear Lube oil (p/n 01154),

Crankcase oil should be changed after the first 50 hours of operation, then at regular intervals of 500 hours or less depending on operating conditions.

2. Pump operation must not exceed rated pressure, volume, or RPM. A pressure relief device must be installed in the discharge of the system.

3. Acids, alkalines, or abrasive fluids cannot be pumped unless approval in writing is obtained before operation from Giant Industries, Inc.

4. Run the pump dry approximately 10 seconds to drain the water before exposure to freezing temperatures.

Specifications

Models P57 & P57-0011

	U.S.	Metric
Flow	1.3 GPM	5.1 Liters/min.
Discharge Pressure (Continuous)	5000 PSI	350 Bar
Discharge Pressure (Intermittent)	6525 PSI	450 Bar
Max. Inlet Pressure	145 PSI	10 Bar
Max. Crankshaft Speed		1420 RPM
Plunger Diameter	0.47"	12 mm
Stroke	0.56"	18.1 mm
Crankcase Oil Capacity	15.2 fl.oz.	0.45 Liters
Max. Temperature of Pumped Fluids	160 °F	70 °C
Inlet Ports		(2) 1/2" BSP
Discharge Ports		(2) 3/8" BSP
Crankshaft Mounting		Either
Shaft Rotation	Top of Pulley Towards Fluid End	
Weight	17.2 lbs.	7.8 Kg.
Crankshaft Diameter	0.87"	22mm

Consult the factory for special requirements that must be met if the pump is to operate beyond one or more of the limits specified above.

PULLEY INFORMATION

Pulley selection and pump speed are based on a 1725 RPM motor and "B" section belts. When selecting desired GPM, allow for a ±5% tolerance on pumps output due to variations in pulleys, belts and motors among manufacturers.

1. Select GPM required, then select appropriate motor and pump pulley from the same line.
2. The desired pressure is achieved by selecting the correct nozzle size that corresponds with the pump GPM.

HORSEPOWER INFORMATION

Horsepower ratings shown are the power requirements for the pump. Gas engine power outputs must be approximately twice the pump power requirements shown above.

We recommend that a 1.1 service factor be specified when selecting an electric motor as the power source. To compute specific pump horsepower requirements, use the following formula:

$$\frac{\text{GPM} \times \text{PSI}}{1460} = \text{hp}$$

P57 PULLEY SELECTION & HORSEPOWER REQUIREMENTS						
PUMP PULLEY	RPM	GPM	3000 PSI	4000 PSI	5000 PSI	6525 PSI*
7.75"	500	0.5	1.0	1.4	1.7	2.3
7.75"	750	0.7	1.4	1.9	2.4	3.2
7.75"	1000	0.9	1.9	2.5	3.1	4.1
7.75"	1250	1.1	2.3	3.0	3.8	5.0
7.75"	1420	1.3	2.7	3.6	4.5	5.9

Exploded View - P57 & P57-0011

Important! The stainless steel valve plugs (41/43) can seize when being screwed out of the casing. To release tension beforehand, strike the plugs 1-2 times with a steel hammer on the top before screwing them out. Coat threads with antiseize (e.g. ProPack 550) before refitting.

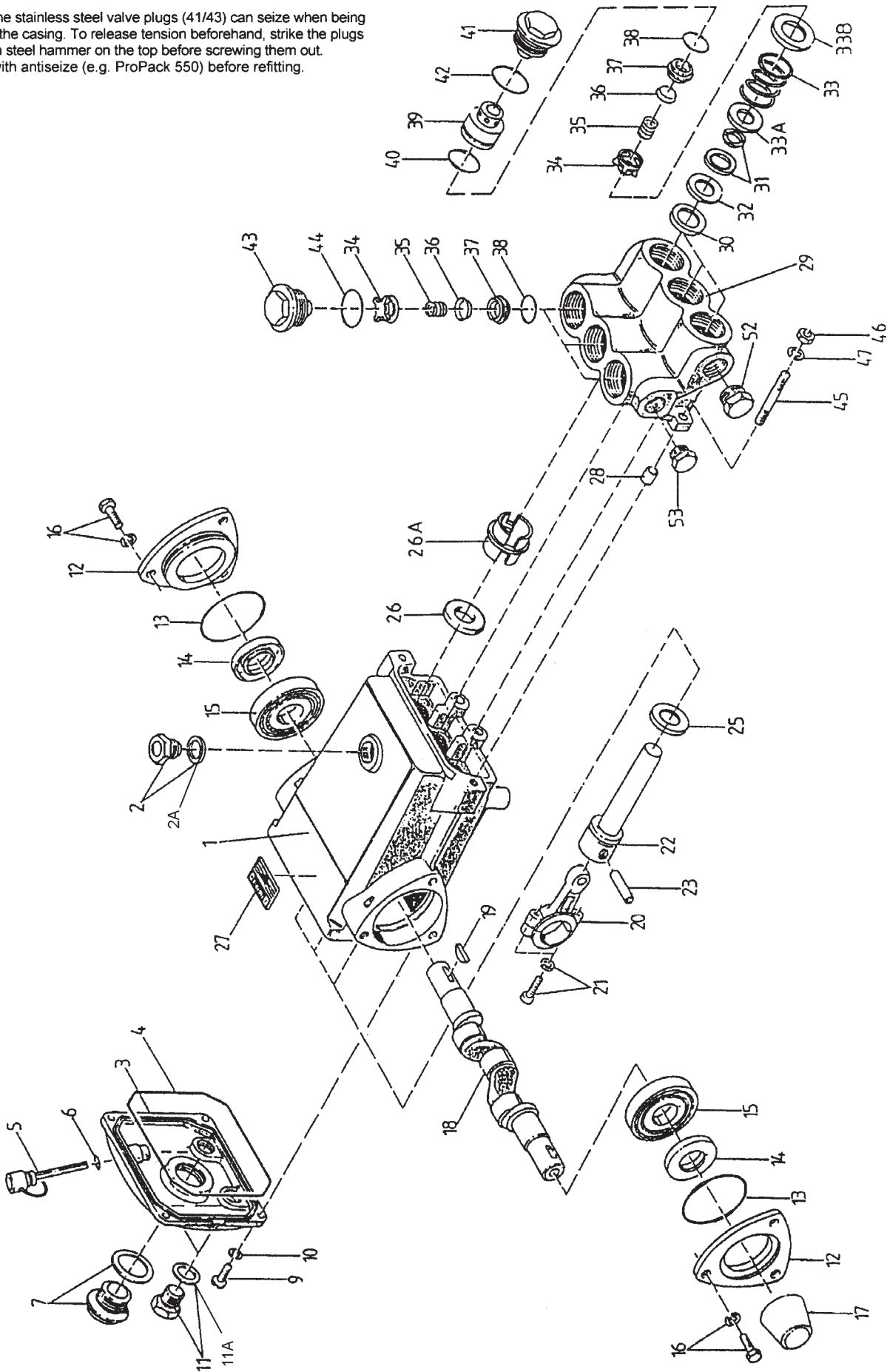

P57 & P57-0011 SPARE PARTS LIST

<u>ITEM</u>	<u>PART</u>	<u>DESCRIPTION</u>	<u>QTY.</u>	<u>ITEM</u>	<u>PART</u>	<u>DESCRIPTION</u>	<u>QTY.</u>
1	07180	Crankcase	1	29	12226	Manifold	1
2	07181	Oil Fill Plug Assembly	1	30	12130	Pressure Ring	3
2A	07182	Gasket	1	31	08354	Grooved Seal (P57)	3
3	07183	Cover, Crankcase	1	31	07391-0010	Grooved Seal, Viton (P57-0011)	3
4	07184	O-Ring, Crankcase Cover	1	32	07941	Support Ring	3
5	07185	Oil Dip Stick Assembly	1	33	12132	Pressure Spring	3
6	01009	O-Ring, Dip Stick	1	33A	12133	Support Disc I	3
7	07186	Oil Sight Glass Assembly	1	33B	12134	Support Disc II	3
9	07188	Screw, Crankcase Cover	4	34	07907	Spring Tension Disc	6
10	07223-0100	Spring Washer	4	35	07906-0100	Valve Spring	6
11	07190	Oil Drain Plug Assembly	1	36	07491	Valve Plate	6
11A	07191	Gasket	1	37	07849	Valve Seat	6
12	13402	Bearing Cover	2	38	07853	O-Ring (P57)	6
13	07193	O-Ring, Bearing Cover	2	38	07853-0001	O-Ring, Viton (P57-0011)	6
14	01166	Radial Shaft Seal	2	39	07940	Suction Valve Retainer	3
15	01086	Bearing	2	40	07212	O-Ring (P57)	3
16	07114	Hex Screw with Washer	6	40	07212-0001	O-Ring, Viton (P57-0011)	3
17	05023	Shaft Protector	1	41	12135	Plug, Inlet	3
18	12128	Crankshaft	1	42	07214	O-Ring (P57)	3
19	01024	Woodruff Key	1	42	07214-0001	O-Ring, Viton (P57-0011)	3
20	07199	Connecting Rod	3	43	12136	Plug, Outlet	3
21	01027	Screw with Washer	6	44	07913	O-Ring (P57)	3
22	07396	Plunger Assy.	3	44	07913-0001	O-Ring, Viton (P57-0001)	3
23	01031	Crosshead Pin	3	45	07215	Stud Bolt	4
25	13403	Flinger	3	46	08040	Hex Nut	4
26	08026	Radial Shaft Seal	3	47	08041	Spring Ring	4
26A	13346	Spacer Sleeve	3	52	12250	Plug, 1/2" BSP, S.S.	1
28	07207	Centering Sleeve	2	53	12138	Plug, 3/8" BSP, S.S.	1

P57 & P57-0011 REPAIR KITS

Plunger Packing Kit #09313 (P57)

<u>Item</u>	<u>Part #</u>	<u>Description</u>	<u>Qty.</u>
31	08354	Grooved Seal	3
32	07941	Support Ring	3
40	07212	O-Ring	3
42	07214	O-Ring	3

Plunger Packing Kit #09313-0011 (P57-0011)

<u>Item</u>	<u>Part #</u>	<u>Description</u>	<u>Qty.</u>
31	07391-0010	Grooved Seal Assy.	3
32	07941	Support Ring	3
40	07212-0001	O-Ring, Viton	3
42	07214-0001	O-Ring, Viton	3

Valve Assembly Kit #09315 (P57)

<u>Item</u>	<u>Part #</u>	<u>Description</u>	<u>Qty.</u>
34	07907	Spring Tension Disc	6
35	07906-0010	Valve Spring	6
36	07491	Valve Plate	6
37	07849	Valve Seat	6
38	07853	O-Ring	6
40	07212	O-Ring	3
42	07214	O-Ring	3
44	07913	O-Ring	3

Oil Seal Kit #09314 (P57 & P57-0011)

<u>Item</u>	<u>Part #</u>	<u>Description</u>	<u>Qty.</u>
25	13403	Flinger	3
26	08026	Radial Shaft Seal	3

P57 & P57-0011 TORQUE SPECIFICATIONS

<u>Position</u>	<u>Item#</u>	<u>Description</u>	<u>Torque Amount</u>
21	01027	Screw with Washer	133 (in-lbs.)
41	12135	Plug, Inlet	52 (ft.-lbs.)
43	12136	Plug, Discharge	52 (ft.-lbs.)
46	08040	Nut, Stud	35 (ft-lbs)

PUMP SYSTEM MALFUNCTION

PUMP SYSTEM MALFUNCTIONS

<u>MALFUNCTION</u>	<u>CAUSE</u>	<u>REMEDY</u>
The Pressure and/ or the Delivery Drops	Worn packing seals	Replace packing seals
	Broken valve springs	Replace springs
	Belt slippage	Tighten or Replace belt
	Worn or Damaged nozzle	Replace nozzle
	Fouled discharge valve	Clean valve assembly
	Worn or Plugged relief valve on pump	Clean, Reset, and Replace worn parts
	Cavitations	Check suction lines on inlet of pump for restrictions
	Unloader	Check for proper operation
Water in Crankcase	High Humidity	Reduce oil change intervals
	Worn Seals	Replace seals
Noisy Operating	Worn bearings	Replace bearings, Refill crankcase oil with recommended lubricant
	Cavitation	Check inlet lines for restrictions and/or proper sizing
Rough/Pulsating Operation with Pressure Drop	Worn packing	Replace packing
	Inlet restriction	Check system for stoppage air leaks, correctly sized inlet plumbing to pump
	Accumulator pressure	Recharge/Replace accumulator
	Unloader Cavitation	Check for proper operation Check inlet lines for restrictions and/or proper size
Pump Pressure as Drop at gun Rated, Pressure	Restricted discharge plumbing	Re-size discharge plumbing to flow rate of pump
Excessive Leakage	Worn plungers	Replace plungers
	Worn packing/seals	Adjust or Replace packing seals
	Excessive vacuum	Reduce suction vacuum
	Cracked plungers Inlet pressure too high	Replace plungers Reduce inlet pressure
High Crankcase Temperature	Wrong Grade of Oil	Giant oil is recommended
	Improper amount of oil in crankcase	Adjust oil level to proper amount

Pump Mounting Selection Guide

Bushings

01056 - 22 mm Tapered H Bushing

Pulley & Sheaves

01061 - 7.75" Cast Iron 1 gr. - AB Section

01062 - 7.75" Cast Iron - 2 gr. - AB Section

Rails

01034 -Steel Box Rails

(L=9.25"x W=1.18"x h=1.62")

01075 - Plated Steel Channel Rails

(L=9.00"x W=2.12"x H=2.50")

Preventative Maintenance Check-List & Recommended Spare Parts List

Check	Daily	Weekly	50hrs	Every 500 hrs	Every 1500 hrs	Every 3000 hrs
Oil Level/Quality	X					
Oil Leaks	X					
Water Leaks	X					
Belts, Pulley		X				
Plumbing		X				
Recommended Spare Parts						
Oil Change (1 Quart) p/n 01153			X	X		
Seal Spare Parts (1 kit/pump) (See page 5 for kit list)					X	
Oil Seal Kit (1 kit/pump) (See page 5 for kit list)					X	
Valve Spare Parts (1 kit/pump) (See page 5 for kit list)						X

REPAIR INSTRUCTIONS - P57 & P57-0011

CAUTION

The stainless steel valve plugs (41 and 43) can seize (when being removed from the manifold). To release tension beforehand, strike the plugs 1 to 2 times with a steel hammer on the top (before removing them). When replacing them, make sure that the threads are coated with antiseize, e.g., ProPack550.

To Check Suction and Discharge Valves

Inlet Valves

1. Using a socket wrench, carefully remove valve plugs (41 and 43). Take out the suction valve adaptor (39) along with the suction valve assembly (34-38).
2. Using a soft tool, push the valve assembly (34-38) out of the suction valve adaptor (39).
3. Replace o-rings (38, 40 and 42). Replace valve parts (34-37).
4. Carefully replace the valve plugs and tighten to 52 ft-lbs (70 NM).

Discharge Valves

5. Remove the valve plugs (43). Remove the exposed spring tension cap (34), valve spring (35) and valve plate (36).
6. Using a 12mm (diameter) valve puller, take out the valve seat (37).
7. Replace o-rings (38 and 44). Replace valve parts 34-37.
8. Carefully replace and tighten valve plugs to 52 ft-lbs (70 NM).

To Check Seals and Plunger Pipe

1. Carefully remove the valve plugs (41). Remove stud nuts (46) and washer (47) from the manifold (29). By pulling it out towards the front. Remove the manifold from the plungers (22).
2. Take out the suction valve adaptor (39), tension spring (33), support discs (I and II) and seal unit (30, 31 and 32).
3. Check the surface of the plungers (22). **Any damaged surfaces will cause accelerated wear on the seals. If the plunger (22) is worn, the complete plunger must be changed - see the section below. The ceramic pipe alone cannot be changed due to reasons of precision.**
4. Check and clean the pressure ring and reinstall into the manifold (29).
5. Reinstall the support ring (32). Prior to replacing the seal assembly (31), grease the new seals.
6. Replace the remaining parts into the manifold (29) in the order that they were removed.
7. Evenly tighten the valve casing with the stud nuts (46) to 35 ft-lbs (47.5 NM).

To Check Plungers and Crankcase

1. If oil leaks at plunger outlet (22), the oil seal (26) and the plungers have to be examined (and replaced, if necessary). After removing the valve casing (29) and its components, drain the oil and remove crankcase cover (3) and bearing cover (12).
2. Remove the connecting rod screws (21) and push the outer connecting rod halves as far as possible into the crosshead guides. **Important! The connecting rods are marked for identification. Do not twist the connecting rod halves. Connecting rods are to be fitted back onto the crankshaft journals in their exact original position.**
3. While slightly turning, hit out (using a rubber hammer) the crankshaft (18) to one side. Either press out the second bearing in the crankcase or carefully hit it out with a soft tool. **Important! Do not bend the connecting rod shanks. Check the crankshaft, connecting rod surfaces as well as the shaft seals (26). Rough surfaces indicate a problem with lubrication and/or possible rough running of the pump. If you suspect that the pump has been running under cavitation or heavy pulsations, make improvements on the inlet and/or discharge connections to and from the pump.**
4. If oil has been leaking through the plunger base oil seals (26), remove them by pushing them out from the backside with a socket wrench. With the seal lip facing forward, replace them into the crankcase (1).

To Reassemble

1. Replace the front halves of the connecting rod (22) and plunger assembly (22). **Make sure that they are in the same position and orientation.**
2. Using a soft tool, press in one roller bearing until it lies level with the edge of the bearing hole. Mount the other bearing onto the crankshaft.
3. Carefully press in the crankshaft through the opposite bearing hole being particularly careful with the journals.
4. Install radial shaft seal (15), bearing cover (12) and o-ring (13).
5. Replace the back-halves of the connecting rods (**to their original position and orientation**) and tighten to 133 in-lbs (15 NM). **Important! After assembly has been completed, the crankshaft should turn easily (with very little movement).**
6. Replace the flinger (25) on the plunger (22)
7. Replace the back cover (3) o-ring (4), manifold (29) and its contents. Tighten the nuts (46) to 35 ft-lbs (47.5 NM).
8. Make sure Fill the crankcase (1) with the proper amount of oil.

NOTE: Contact Giant Industries for Service School Information. Phone: (419)-531-4600

P57 & P57-0011 PUMP DIMENSIONS (MM)

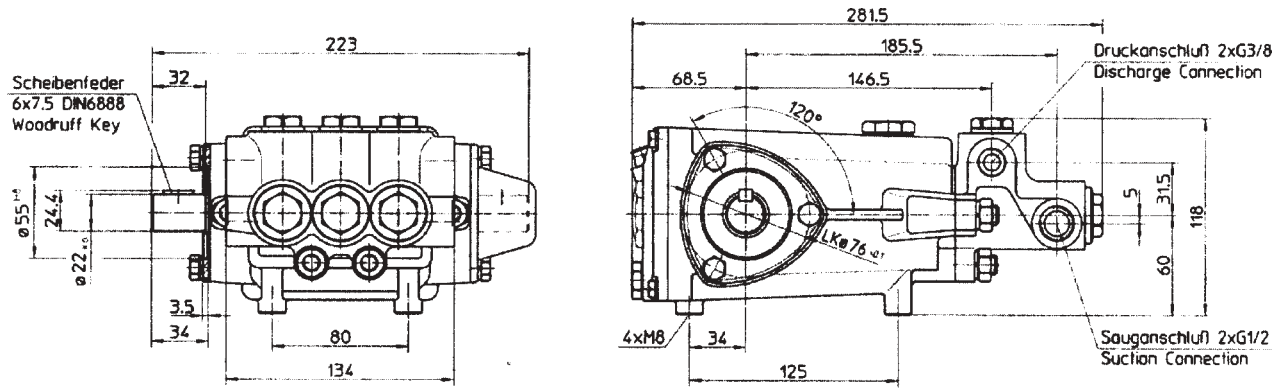

GIANT INDUSTRIES LIMITED WARRANTY

Giant Industries, Inc. pumps and accessories are warranted by the manufacturer to be free from defects in workmanship and material as follows:

1. For portable pressure washers and car wash applications, the discharge manifolds will never fail, period. If they ever fail, we will replace them free of charge. Our other pump parts, used in portable pressure washers and in car wash applications, are warranted for five years from the date of shipment for all pumps used in NON-SALINE, clean water applications.
2. One (1) year from the date of shipment for all other Giant industrial and consumer pumps.
3. Six (6) months from the date of shipment for all rebuilt pumps.
4. Ninety (90) days from the date of shipment for all Giant accessories.

This warranty is limited to repair or replacement of pumps and accessories of which the manufacturer's evaluation shows were defective at the time of shipment by the manufacturer. The following items are NOT covered or will void the warranty:

1. Defects caused by negligence or fault of the buyer or third party.
2. Normal wear and tear to standard wear parts.
3. Use of repair parts other than those manufactured or authorized by Giant.
4. Improper use of the product as a component part.
5. Changes or modifications made by the customer or third party.
6. The operation of pumps and or accessories exceeding the specifications set forth in the Operations Manuals provided by Giant Industries, Inc.

Liability under this warranty is on all non-wear parts and limited to the replacement or repair of those products returned freight prepaid to Giant Industries which are deemed to be defective due to workmanship or failure of material. A Returned Goods Authorization (R.G.A.) number and completed warranty evaluation form is required prior to the return to Giant Industries of all products under warranty consideration. Call (419)-531-4600 or fax (419)-531-6836 to obtain an R.G.A. number.

Repair or replacement of defective products as provided is the sole and exclusive remedy provided hereunder and the MANUFACTURER SHALL NOT BE LIABLE FOR FURTHER LOSS, DAMAGES, OR EXPENSES, INCLUDING INCIDENTAL AND CONSEQUENTIAL DAMAGES DIRECTLY OR INDIRECTLY ARISING FROM THE SALE OR USE OF THIS PRODUCT.

THE LIMITED WARRANTY SET FORTH HEREIN IS IN LIEU OF ALL OTHER WARRANTIES OR REPRESENTATION, EXPRESS OR IMPLIED, INCLUDING WITHOUT LIMITATION ANY WARRANTIES OR MERCHANTABILITY OR FITNESS FOR A PARTICULAR PURPOSE AND ALL SUCH WARRANTIES ARE HEREBY DISCLAIMED AND EXCLUDED BY THE MANUFACTURER.



GIANT INDUSTRIES, INC., 900 N. Westwood Ave., P.O. Box 3187, Toledo, Ohio 43607
 PHONE (419) 531-4600, FAX (419) 531-6836, www.giantpumps.com
 © Copyright 2007 Giant Industries, Inc.