



"Serving Those Who Serve The Very Best"

# Users Manual

## TOP SIDE™ COOKER SERIES 2005

READ AND SAVE THIS MANUAL FOR FUTURE REFERENCE.

RECORD THE MODEL AND SERIAL  
NUMBERS OF THIS TOP SIDE™ COOKER  
IN THE SPACES PROVIDED.

SERIAL NO. \_\_\_\_\_  
MODEL NO. \_\_\_\_\_

**KEEP THESE NUMBERS FOR FUTURE REFERENCE.**

**IMPORTANT:** Keep a copy of your bill of sale. The date on the bill establishes the warranty period should service be required. If service is performed, it is in your interest to obtain and keep all receipts. Keating commercial griddles are not intended for household use.

The Owner's Guide provides specific operating instructions for your model. Use the Top Side™ Cooker only as instructed in this Service Guide.

### CONTENTS:

#### SECTION I: INTRODUCTION

GENERAL .....	1
STANDARD FEATURES .....	1
STANDARD ACCESSORIES .....	1
COOKING HEAD SPECIFICATIONS .....	1
SAFETY PRECAUTIONS .....	1

#### SECTION II: INSTALLATION

DAMAGE DURING SHIPMENT .....	1
INSTALLATION .....	1
CONDITIONING THE GRIDDLE .....	2
ELECTRICAL CONNECTION .....	2

#### SECTION III: OPERATING

COOKING .....	2
COOKING HEIGHT ADJUSTMENT .....	2
DIGITAL TIMER PROGRAMMING .....	2
SHUTDOWN .....	3
CLEANING PROCEDURES .....	3
A. KEATING COOKING SHEET .....	3
B. COOKING SHEET CLIPS .....	3
C. COOKING HEAD .....	3

#### SECTION IV: MAINTENANCE

WARRANTY REPAIRS .....	4
PREVENTIVE MAINTENANCE .....	4
INSTALLING A COOKING SHEET .....	5
HANDLING COOKING SHEETS .....	5
LEVELING OF COOKING HEAD .....	5
REMOVAL OF COOKING HEAD .....	5

#### SECTION V: SERVICE DIAGNOSIS

TROUBLE-SHOOTING CHART .....	6
TROUBLE-SHOOTING THE THERMOSTAT .....	7

#### SECTION VI: PARTS LIST

ORDERING PARTS .....	8
WARNING AND OPERATING PLATES .....	8
TOP-SIDE™ MANUAL COOKING HEAD (EXPLODED VIEW) ..	8
TOP-SIDE™ COOKING HEAD PARTS LIST .....	9
TOP-SIDE™ AUTO-LIFT COOKING HEAD .....	10
TOP-SIDE™ AUTO-LIFT ACTUATOR MICROSWITCH .....	11
CONTROL PANEL ASSEMBLY .....	12
POWER SUPPLY BOX AUTO-LIFT HEAD .....	13-14

#### SECTION VII: WIRING DIAGRAM

WIRING DIAGRAMS .....	15-18
-----------------------	-------

Keep this manual for training new personnel.





1-800-KEATING  
www.keatingofchicago.com

① **NOTICE:** This operating, installation, and service manual should be given to the user. The operator of the Top-Side Cooker™ should be familiar with its functions and operation. This manual must be kept in a prominent, easily reachable location near the Top-Side Cooker™.

① **NOTICE:** Keating of Chicago, Inc. (manufacturer) reserves the right to change specifications at any time.

<p><b>⚠ WARNING</b></p>  <p>Do not store flammable liquids near this or any other appliance.</p>	<p><b>⚠ WARNING</b></p> <p><b>DO NOT STORE OR USE GASOLINE OR OTHER FLAMMABLE VAPORS OR LIQUIDS IN THE VICINITY OF THIS OR ANY OTHER APPLIANCE.</b></p>
---	---

<p><b>⚠ WARNING</b></p> <p>Gas Burns Shock</p>   <p>Improper installation can cause damage, injury or death.</p>	<p><b>⚠ WARNING</b></p> <p><b>IMPROPER INSTALLATION, ADJUSTMENT, SERVICE OR MAINTENANCE CAN CAUSE PROPERTY DAMAGE, INJURY OR DEATH. READ THE INSTALLATION, OPERATING AND MAINTENANCE INSTRUCTIONS THOROUGHLY BEFORE INSTALLING OR SERVICING THIS EQUIPMENT.</b></p>
--	---

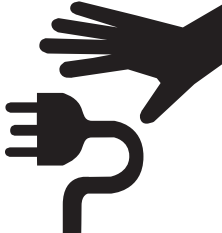
<p><b>⚠ WARNING</b></p>  <p>Disconnect all power before servicing.</p>	<p><b>⚠ WARNING</b></p> <p><b>BEFORE OBTAINING ACCESS TO TERMINALS, ALL SUPPLY CIRCUITS MUST BE DISCONNECTED.</b></p>
---	---

---

# I INTRODUCTION

---

## GENERAL

Keating Top-Side™ Cookers are designed to give maximum production efficiency, delivering high quality food products. The following design features are incorporated into Keating Top-Side™ Cookers.

---

## STANDARD FEATURES

- Stainless steel control panel
- Stainless steel head cover
- MIRACLEAN® cooking surface
- Solid State Thermostat
- Adjustable cooking height, from 1/8" to 1 1/2" (3mm to 38mm)
- Locking mechanism for micro-level

---

## STANDARD ACCESSORIES

- Proprietary USDA and UL listed polymer cooking sheets (1)

**NOTE:** Keating of Chicago, Inc. (manufacturer) reserves the right to change specifications at any time.

---

## COOKING HEAD SPECIFICATIONS

Each Top-Side™ cooking head is designed to be connected to a 208, 220 or 240 volt single phase line.

HEIGHT	WIDTH	DEPTH	WATTS	AMPS	kW
3 5/8" (92mm)	10 1/2" (267mm)	20" (508mm)	4,000 @220V	18 @220V	4.0 @220V

---

## STANDARD TOP-SIDE™ COOKERS

- Sizes: 1 to 6 heads.
- Mounting: Can be mounted to any standard MIRACLEAN® gas or electric 30" (762mm) deep griddle (24" deep plate / 610mm) up to 72" wide (up to 6 heads maximum). Front trough only griddles are preferred for multiple heads.
- Cooking Surface: 10 1/2" (267mm) wide x 20" (508mm) deep (per cooking head).
- Number of heads: One head can be used for every 12" (305mm) of plate width. Each Top-Side™ cooking head will be positioned over a griddle thermostat to ensure peak efficiency.
- ETL and ETL Sanitation listed.

---

## SAFETY PRECAUTIONS



**THIS SYMBOL WARNS YOU THAT SERIOUS BURNS OR OTHER INJURIES MAY RESULT IF SAFETY INSTRUCTIONS ARE NOT FOLLOWED.**

- DO NOT SUBMERGE THE TOP-SIDE™ COOKING HEAD IN WATER.
- CLEANING CHEMICALS OR UTENSILS USED FOR CLEANING GRIDDLES WILL DAMAGE OR DESTROY THE POLYMER COOKING SHEET.
- NEVER USE A WATER JET TO CLEAN.

---

## II INSTALLATION

This Top-Side™ Cooker **MUST** be installed on a Keating griddle only. Failure to do so voids the warranty.

The Top-Side™ Cooker must be installed, inspected, calibrated and serviced by qualified, certified and/or licensed service personnel. Contact your dealer for assistance.

---

## DAMAGE DURING SHIPMENT

The Top-Side™ Cooker has been assembled, tested and inspected at the factory. Upon arrival, the complete Top-Side™ Cooker should be thoroughly checked for any damage that may have occurred during shipment.

### What to do if equipment arrives damaged:

**VISIBLE LOSS OR DAMAGE-** Be certain to note this on the freight or express receipt and have it signed by the delivery person.

**FILE CLAIM FOR DAMAGES IMMEDIATELY-** Regardless of extent of damage.

**CONCEALED LOSS OR DAMAGE-** If the damage is noticed when the equipment is unpacked, notify the freight company immediately, and file a "concealed damage claim". This **MUST** be done immediately. Be sure to retain the shipping container for inspection.

Keating does not assume responsibility for **loss OR damage** incurred in transit.

---

## INSTALLATION

On new installations, your Top-Side™ Cooker has already been factory installed, tested leveled and inspected. Top-Side™ Cookers cannot be mounted onto existing Miraclean® griddles in the field.

---

## ELECTRICAL CONNECTION

Each Keating Top-Side™ Cooking head is equipped with a 9' (2.74m) neoprene covered, 12 gauge 4mm(2), three wire with ground electrical cord. Each cooking head is rated 4000W, 18 amps, single phase at 220 Volts and is designed to be connected to its own 208-240V single phase electrical supply. For proper connecting and grounding procedure see local codes, the National Electrical Code ANSI/NFPA 70 (latest edition) or Canadian Electrical Code CAN C22.1 (latest edition) as applicable.

### **⚠ WARNING**

**THIS APPLIANCE MUST BE EARTHED.**

---

## III OPERATING

### **⚠ CAUTION**

Food will cook much faster with a Top-Side™ Cooker than with a griddle alone. Watch food while cooking or use timers to ensure food will not be overcooked.

### **⚠ WARNING**

**OPERATION OF THE TOP-SIDE™ COOKER SHOULD BE LIMITED TO PERSONNEL THOROUGHLY TRAINED IN OPERATING PROCEDURES.**

---

## CONDITIONING THE GRIDDLE

The MIRACLEAN® Griddle plate has been “seasoned” at the factory. The chrome surface when heated creates a thin layer of chrome oxide which acts as a releasing agent for food products. If you feel you need to recondition the surface, the following instructions should be followed:

1. Follow cleaning instructions on this page & next.
2. Heat the MIRACLEAN® to 400°F for one hour.
3. Lower thermostat to 350°F, allowing the MIRACLEAN® to cool to about 350°F, as is evident when griddle cycles on or surface thermometer indicates correct temperature.
4. Lightly coat the MIRACLEAN® surface with griddle oil.

**NOTE:** Despite the food releasing properties, the chrome surface is not a true “non-stick” surface. For best cooking results and product appearance, use griddle oil for products that require the surface to be conditioned.

---

## COOKING

1. Turn ON/OFF switch to “ON” position.
2. Press and hold the “Push to Set” button on the thermostat and adjust the knob to the desired temperature. The new temperature will be entered after 3 seconds. Red “ELEMENT ON” light will illuminate when the element is on.

**NOTE:** To increase temperature, adjust knob clockwise. To decrease, adjust knob counterclockwise.

Figure 3-1

Top-Side™ Cooker Control Panel

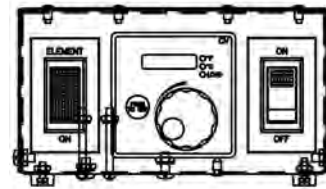

---

## COOKING HEIGHT ADJUSTMENT

Keating's Top-Side™ Cooker has been designed to allow you infinite height adjustments from 1/8" to 1 1/2" (approximately 3mm to 38mm). An adjusting knob allows fast and precise height adjustment.

Clockwise movement of the knob will decrease the spacing; counter clockwise movement will increase the spacing. Each turn of the adjusting knob represents 1/8" (approximately 3mm) movement.

Experimentation will give you the best cooking height for each type of food product. The cooking head should contact the product firmly to ensure optimum heat distribution without flattening the product.

---

## DIGITAL TIMER PROGRAMMING FOR AUTO-LIFT HEADS ONLY

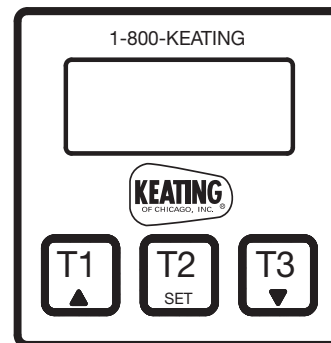

The electronic timers provide a clearly visible and accurate display and are very easy to use. Three different, independent cook times can be set using this timer - T1, T2 and T3. When cook time has reached “00:00”, the cooking head will automatically raise.

## Programming

To program the timers, the unit must be in the idle mode. Press and hold the set button for approximately two seconds. The display will show "SEt". Press T1, T2 or T3 for the cook time to be programmed. The display will show the current setting for that cook time. Use the up or down button to increment or decrement the setting. When the setting is correct, press and hold the set button again for approximately two seconds. The display will show "StO" for approximately two seconds and the timer will return to normal operation. Repeat the process as necessary for the other timers.

## Operating Logic

When the timer is powered up, the display will show the time setting for the channel that was operated last and the relay output contacts will be open. To start a cycle, press the desired cook time button (T1, T2 or T3). The display will begin to countdown from the preset time setting and the relay output contacts will close. During the countdown the colon will flash at a one-second rate. When the countdown has reached "00:00" the relay output contacts will open, the display will flash, and the audible alarm will sound. To cancel the audible alarm, press any button.

## Pause Feature

To pause a cycle in progress, press any button. The relay output contacts will open, the display will flash, and the countdown will pause. To resume the countdown, press any button. The display will resume the normal countdown and the relay output contacts will close.

---

## SHUTDOWN

Turn ON/OFF switch to "OFF" position.

---

## CLEANING PROCEDURES

### A. Keating Cooking Sheets

- Clean cooking sheets with a damp soft cloth after each run of product (a Turkish towel works best).

## WARNING

**THE COOKING HEAD WILL BE HOT. USE PROPER CARE WHEN CLEANING THE COOKING SHEETS.**

### End of day cleaning:

Before the griddle is turned off for the day, the cooking sheets should be cleaned as described below. Wear heat resistant gloves for maximum safety during the entire cleaning procedure.

1. At the end of the day, wipe the cooking sheet in place with a damp soft cloth. Continue wiping until the surface of the cooking sheet is free of any residue.

2. Remove the cooking sheet from the cooking head. Clean the cooking head and the griddle surfaces.
3. Wash the cooking sheet with a mild detergent in warm water and dry thoroughly.
4. If needed, after the cleaning is complete, reverse the cooking sheet and reattach it to the cooking head.

### B. Cooking Sheet Clips

To remove the stainless steel cooking sheet clips for cleaning, simply lift them off. They can be cleaned in a dishwasher.

### C. Cooking Head

The MIRACLEAN® surface is very durable and with proper care, following the procedures below, will last many years.

1. Scrape MIRACLEAN® surface from front to back with the Keating griddle scraper with Cooking Sheets removed.
2. Clean and polish surface with Keating Klenzer on a damp soft cotton cloth. Wipe off excess Klenzer.

## WARNING

**BECAUSE OF THE SUPERIOR MIRACLEAN® SURFACE, THE ONLY TOOLS YOU WILL EVER NEED TO CLEAN THE TOP-SIDE™ COOKING HEAD ARE A DAMP SOFT COTTON CLOTH AND A KEATING SCRAPER.**

- NEVER SCRAPE COOKING SHEETS WITH THE SCRAPER.
- NEVER USE A GRIDDLE STONE, BRICK, GRIDDLE SCREEN OR HARSH CHEMICALS TO CLEAN THE MIRACLEAN® SURFACE.
- DAMAGE DONE TO THE MIRACLEAN® SURFACE BY GRIDDLE STONE, BRICK, SCREEN, OR HARSH CHEMICALS WILL VOID THE WARRANTY.
- THE DAMAGE DONE TO THE MIRACLEAN® SURFACE IS IRREPARABLE.
- NEVER USE ICE TO COOL THE MIRACLEAN® SURFACE AS IT MAY WARP THE MIRACLEAN® SURFACE.
- USE ONLY KEATING SUPPLIED CLEANING TOOLS AND KLENZER.
- USE ONLY A KEATING STEEL SPATULA.

**NOTE:** Keating Klenzer MSDS Sheet available on website, [www.keatingofchicago.com](http://www.keatingofchicago.com)

## **⚠ WARNING**

Do not hack, chop or hit the surface. You will dent the steel plate under the trivalent chrome. It is even possible to hack two nicks close together and actually tear the MIRACLEAN® surface as the chromium will not stretch. Below is a sketch showing a side view of a cooking head and how the surface can be damaged. Proper use of the utensils supplied with your MIRACLEAN® Griddle will prevent surface damage.

### Surface Damage

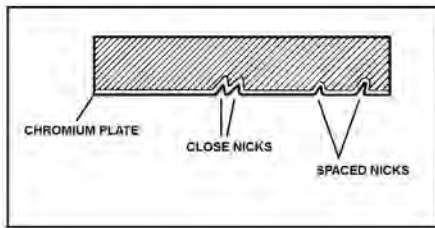

## **IV MAINTENANCE**

### **WARRANTY REPAIRS**

Keating's warranty begins with the date of installation. In the event your Keating Top-Side™ Cooker needs repair under warranty other than routine maintenance or cleaning you are requested to contact KEATING OF CHICAGO, INC. at 1-800-KEATING before calling a local service company.

**NOTE:** The cooking sheets are not covered under warranty.

### **PREVENTIVE MAINTENANCE**

Preventive maintenance should be done in daily, weekly, monthly and yearly intervals as necessary. Following preventive maintenance procedures will help keep your Top-Side™ Cooker working efficiently. Proper care and servicing will lead to years of quality performance.

<b>TIME FRAME</b>	<b>OPERATOR/OWNER</b>	<b>SECTION</b>
<b>At Least Daily</b>	<ul style="list-style-type: none"> <li>• Clean all cooking sheets.</li> <li>• Clean MIRACLEAN® Griddle surface.</li> </ul>	III
<b>At Least Weekly*</b>	<ul style="list-style-type: none"> <li>• Clean all surfaces of Top-Side™ Cooker.</li> </ul>	III
<b>Monthly*</b>	<ul style="list-style-type: none"> <li>• Verify thermostat settings.</li> <li>• Review cooking procedures.</li> <li>• Check Cooking Sheets (Replace if necessary).</li> </ul>	IV & V III
<b>At Least Yearly*</b>	<p style="text-align: center;"><b>QUALIFIED SERVICE PERSONNEL ONLY</b></p> <ul style="list-style-type: none"> <li>• Thoroughly check and test Top-Side™ Cooker.</li> <li>• Calibrate controls.</li> </ul>	IV & V
<p style="text-align: center;"><i>*High production facilities should be checked more often. Contact the factory or a local service company to perform maintenance and repairs.</i></p>		

Proper care should be taken to fully clean the Top-Side™ Cooker on a regular basis. The control panel should be cleaned of any greasy residue with a damp cotton cloth. Remove any residue from the ON/OFF switch and the thermostat. Wipe down the cabinet, sides and back on a regular basis.

---

## INSTALLING A COOKING SEET

1. Raise Top-Side™ Cooking head completely.
2. Lay the 20" x 24" (508mm x 610mm) cooking sheet on the griddle plate with 20" (508mm) dimension front to back.
3. Lower the Top-Side™ Cooker head onto the cooking sheet, ensuring that the sheet is centered under the head, the front edge of the sheet is even with the front edge of the head, and the sides of the sheet are parallel to the side of the head.
4. Fold both edges of the cooking sheet over the head. While gently pulling the right side of the sheet to remove any slack, firmly push the cooking sheet mounting clip onto the right side mounting rib on top of the head.
5. Repeat process on the left side.
6. Reverse the process to remove the cooking sheet.

---

## TIPS ON PROPER HANDLING AND USE OF COOKING SHEETS

To ensure long life of your Keating cooking sheets please follow the tips below:

### Cooking sheets should never:

- Be folded or creased.
- Be touched with sharp objects.
- Come in contact with griddle scrapers or abrasive pads.
- Be placed under other equipment or objects.

### Cooking sheets should always:

- Be wiped with a damp soft cotton cloth after each run to remove any product residue.
- Be cleaned after the griddle is shut down for the day.

### The time to change a Cooking Sheet is when:

- Product starts sticking to the sheet.
- Too much carbon build-up causes a product appearance, cooking or taste problem.
- The head surface is cool.
- The sheet is torn or ripped.

## WARNING

**THE TOP-SIDE™ COOKING HEAD AND GRIDDLE PLATE ARE HOT - USE PROPER CARE WHEN CHANGING THE COOKING SHEETS.**

---

## LEVELING OF COOKING HEAD(S)

The cooking head(s) were leveled at the factory.

**NOTE:** For best results, level griddle before checking. Adjust legs or stand casters to level griddle.

---

## REMOVAL OF COOKING HEAD

**NOTE:** To identify parts, refer to page 8.

1. Turn off griddle and disconnect Top-Side™ Cooker electric power.
2. Remove the cooking sheet by lifting off cooking sheet mounting clips.
3. Place a layer of soft cloth and then a layer of cardboard onto griddle plate under cooking head to protect MIRACLEAN® surface.
4. Raise cooking head completely to release tension on cooking head support pin. Remove support pin and its cotter pin and carefully lower cooking head to protected griddle surface.

## WARNING

The cooking head is not supported after the cooking head support pin has been removed. If dropped the weight of the cooking head when unsupported will cause damage to the griddle surface or injury to personnel.

5. Do not turn the support pin in either direction.
6. To reattach the cooking head to the ram lift arm, raise cooking head completely and replace cooking head support pin. Insert a new stainless steel cotter pin to secure support pin, holding support pin to keep it from spinning.
7. Replace cooking sheet. See - "Installing a Cooking Sheet".

# V SERVICE DIAGNOSIS

A properly adjusted Keating Top-Side™ Cooker, with no load, will cycle “ON” approximately every 5½ to 6½ minutes. Each cycle will last 40 seconds, ensuring that the temperature setting is held within a narrow range.

## A. Trouble-Shooting

The following diagnosis is only to be used as a guide to qualified service personnel. Keating recommends that you use a qualified service company.



**Disconnect power before servicing.**

PROBLEM	PROBABLE CAUSE	SOLUTION
POWER ON light does not come on.	a.No electricity to Top-Side™ Cooker. b.ON/OFF switch is faulty.	a.Connect Top-Side™ Cooker to an approved source of power. b.Replace ON/OFF SWITCH
ELEMENT ON light does not come on and cooking head will not heat.	a.Connections to thermostat are loose or thermostat is faulty. b.Connections to thermostat temperature probe are loose or probe is faulty. c.Hi-Limit has tripped or Hi-Limit is faulty. Note: Hi-Limit is self-resetting. d.Connections to Hi-Limit are loose or Hi-Limit is faulty. e.Connections to contactor are loose or contactor is faulty. f. ON/OFF switch is faulty.	a.Check connections and tighten where necessary. If thermostat is faulty, replace. b.Check connections and tighten where necessary. If probe is faulty, replace it. c. Wait until cooking head cools down. If ELEMENT ON light will not come on Hi-Limit is faulty, replace it. d.Check connections and tighten where necessary. e.Check connections and tighten where necessary. If contactor is faulty, replace it. f. Replace ON/OFF switch.
ELEMENT ON light does not come on, but cooking head does heat.	a.ELEMENT ON light is faulty.	a.Replace ELEMENT ON light.
ELEMENT ON light flashes once whenever power is turned on.	a.Thermostat temperature probe or wires have shorted out.	a.Replace probe and/or wires. Use conductive heat paste when installing new probe.
Temperature of cooking head is erratic.	a.If erratic, thermostat is faulty.	a.Replace thermostat.



## TROUBLESHOOTING THE THERMOSTAT

<p>Temperature reading is incorrect, showing a sensor error, <b>Err</b> or <b>LOAD LED</b> is switching at the wrong temperature.</p>	<ul style="list-style-type: none"> <li>• Sensor or controller may be bad. Sensor connections may be bad.</li> <li>• Controller is wired incorrectly.</li> </ul>	<p>Place a jumper wire across the thermocouple input terminals. The display should indicate ambient temperature. If it does, the controller is ok. If not, replace controller.</p> <p>Decrease set point below ambient temperature, <b>LOAD LED</b> should be off for heating controllers. If it is, the controller is OK.</p> <p>Increase set point above ambient temperature. <b>LOAD LED</b> should be on for heating controllers. If it is, the controller is OK.</p> <p>Verify proper wiring. Call 1-800-KEATING for a diagram.</p>
<p>Temperature reading is decreasing, but actual temperature is increasing.</p>	<ul style="list-style-type: none"> <li>• Thermocouple polarity is reversed. Red wire denotes negative wire.</li> <li>• Ambient temperature in the control cabinet is over 70°C.</li> </ul>	<p>Check thermocouple connections. All connections, including extension wire, must maintain the correct polarity. Correct if needed.</p> <p>Measure temperature in cabinet to ensure it is below 70°C.</p>

For troubleshooting the thermocouple, use the chart below

**Top-Side™ Cooker Probe Chart (Part # 016671)**

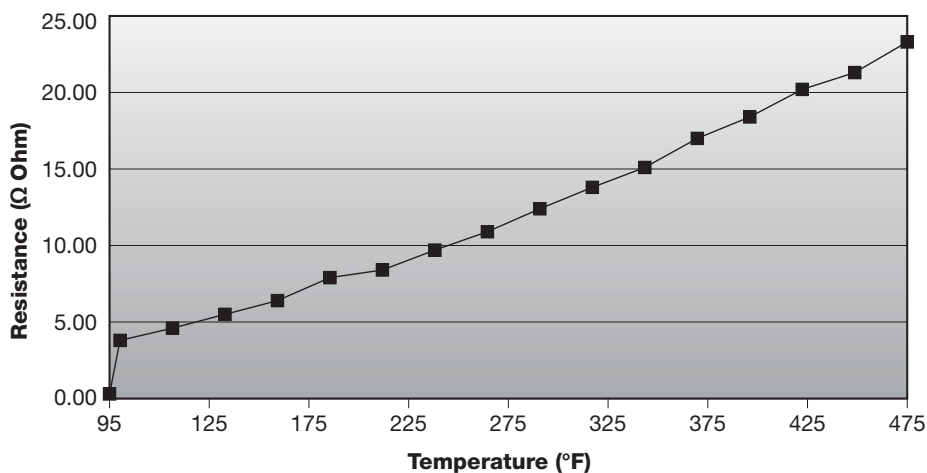

Temperature (°F)	Resistance (Ohm)
95	0.30
100	3.80
125	4.60
150	5.50
175	6.40
200	7.90
225	8.40
250	9.70
275	10.90
300	12.40
325	13.80
350	15.10
375	17.00
400	18.40
425	20.20
450	21.30
475	23.30

# VI EXPLODED VIEW & PARTS LIST

## ORDERING PARTS

Parts may be ordered by part number by calling 1-800-KEATING or your local service company. You may also order online at Keating's part store, [www.keatingofchicago.com](http://www.keatingofchicago.com).

Refer to the Keating Top-Side™ Cooker Limited Warranty for complete service and ordering information.

The model/serial plate for each cooking head is located on the the control panel assembly. The serial and model numbers are necessary when ordering.

## WARNING AND OPERATING PLATES

All warning and operating plates on the Keating Top-Side™ Cooker should be in place at all times. If plates are damaged or lost, replace them immediately.

## MANUAL LIFT TOP-SIDE™ COOKER

Figure 6-1

Corresponds with parts list on page 8

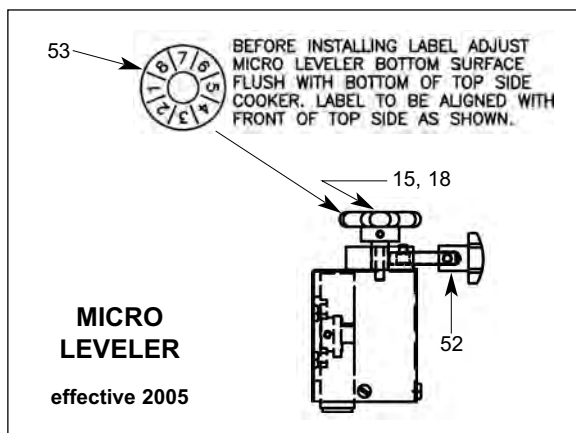
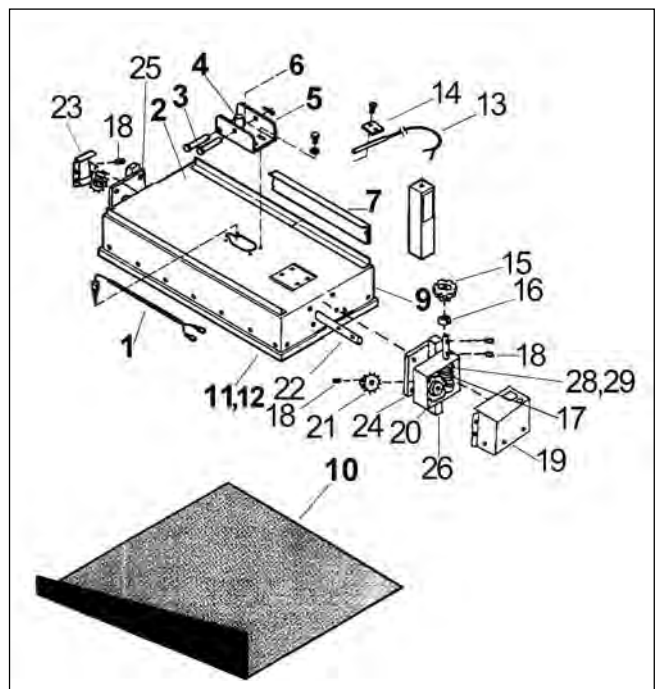
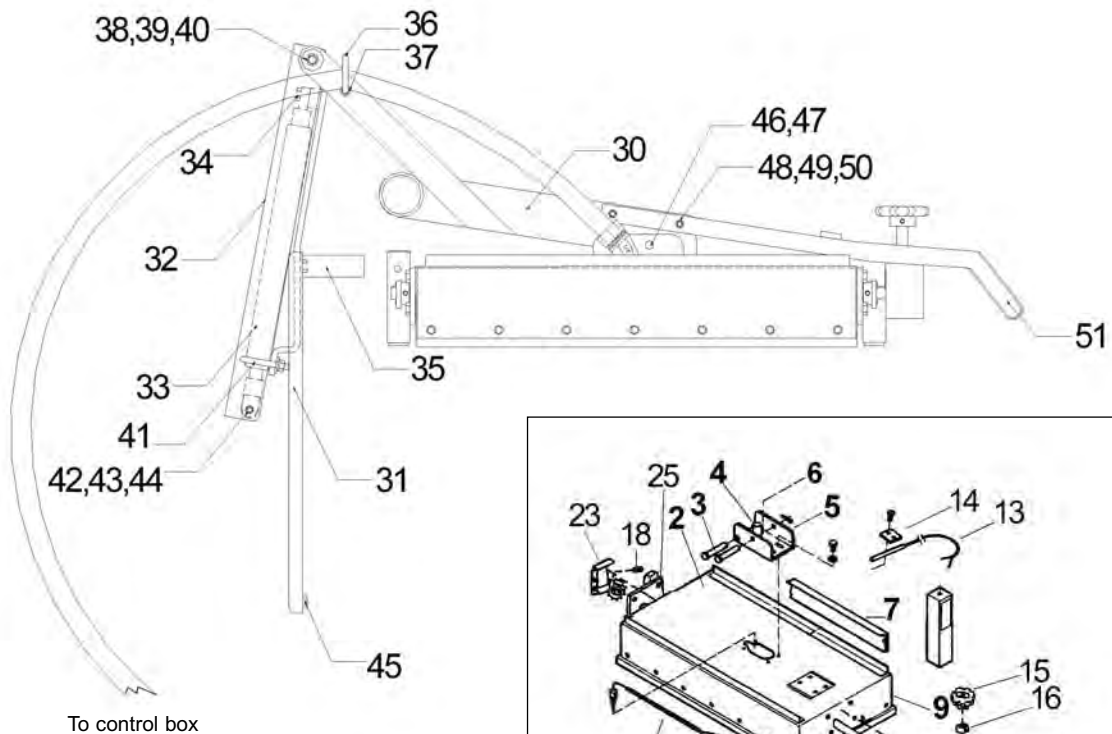

## TOP-SIDE™ COOKING HEAD – MANUAL & AUTO-LIFT

Figure 6-1

ITEM	DESCRIPTION	QTY.	PART NUMBER
1	THERMOSTAT TEMPERATURE PROBE KIT	1	016671
2	COOKING HEAD (COMPLETE)	1	1-800-KEATING
3	STOP CLEVIS PIN, S/S	1	015164
4	SWIVEL BRACKET WIRE SLEEVE (INCL. IN ITEM 5)	1	---
5	SWIVEL BRACKET	1	028181
6	SWIVEL BRACKET SUPPORT CLEVIS PIN, S/S	1	015164
7	COOKING SHEET MOUNTING CLIP	2	017316
9	COVER (FOR TSC WITH MICRO LEVELER)	1	1-800-KEATING
10	COOKING SHEET (SINGLE SHEET)		012118
	COOKING SHEET (PACKAGE OF 12)		012119
11	MIRACLEAN® COOKING FACE PLATE	1	---
12	HEATING ELEMENT 4KW, 220V (NOT SHOWN)	1	056510
	HEATING ELEMENT 480V, 4000W (NOT SHOWN)	1	035664
	INSULATION BOARD (NOT SHOWN)	2	016503
13	HIGH LIMIT PROBE	1	015173
14	HIGH LIMIT PROBE MOUNTING PLATE	1	014247
15	KNOB	1	028622
16	COLLAR	2	028486
17	WORM GEAR	1	028487
18	1/4-20X 1/4" ALLEN SET SCREW	4	028501
19	HOUSING COVER	1	---
20	WORM GEAR WHEEL	1	028488
21	SPUR GEAR	2	030241
22	SHAFT	1	028461
23	REAR COVER	1	---
24	FRONT HOUSING	1	---
25	REAR HOUSING	1	---
26	FRONT PLUNGER	1	028521
27	REAR PLUNGER (NOT SHOWN)	1	028522
28	TEFLON WASHER (NOT SHOWN)	1	028490
29	FIBER WASHER (NOT SHOWN)	2	028500
30	TOP-SIDE COOKER WELD. MANUAL	1	052114
31	TOP-SIDE COOKER SPRING SUPPORT WELDMENT	1	052266
32	MANUAL TOP-SIDE GAS SPRING LIFT	1	052251
33	MANUAL TOP-SIDE COOKER GAS SPRING	1	054444
34	SCREW 5/16-18 X 3/4 HEX HEAD ZINC PLATED	1	015262
35	TOP-SIDE COOKER SUPPORT BRACE GAS	1	052269
36	TOP-SIDE CONDUIT SUPPORT	1	052287
37	NUT RIVET 1/4-20 X 5/8" 0.332 BODY	1	030269
38	WASHER 1/4 ID X 7/8 OD X 1/16 THK NICKEL	2	015414
39	SCREW 1/4-20 X 3/4 SERRATED FLANGE LOCK	6	032328
40	TOP-SIDE COOKER LIFT ARM ROD	1	052117
41	U BOLT WITH MOUNTING PLATE	1	052286
42	SCREW 10-24 X 3/8 SERRATED FLANGE LOCK	2	032327
43	WASHER 0.190 ID X 0.5630 D X 0.047 THK NICKLE	2	013217
44	MANUAL TOP-SIDE COOKER GAS SPRING ROD	1	052252
45	NUT 1/4-20 HEX NICKEL PLATED	1	016383
46	3/8-2 1/2 CLEVIS PIN	2	015164
47	COTTER KEYS S.S.	2	015166
48	1/4-20 X 3" THREADED ROD	2	014226
49	1/4" STAR WASHER	4	017046
50	1/4-20 ACORN NUT	4	015227
51	WELDMENT HANDLE GEAR GAPPING SYSTEM	1	027311
52	TOPSIDE MICRO LEVELER ASSEMBLY	1	057544
53	TOPSIDE MICRO LEVELER LABEL	1	057432

# AUTO-LIFT TOP-SIDE™ COOKER

Figure 6-2

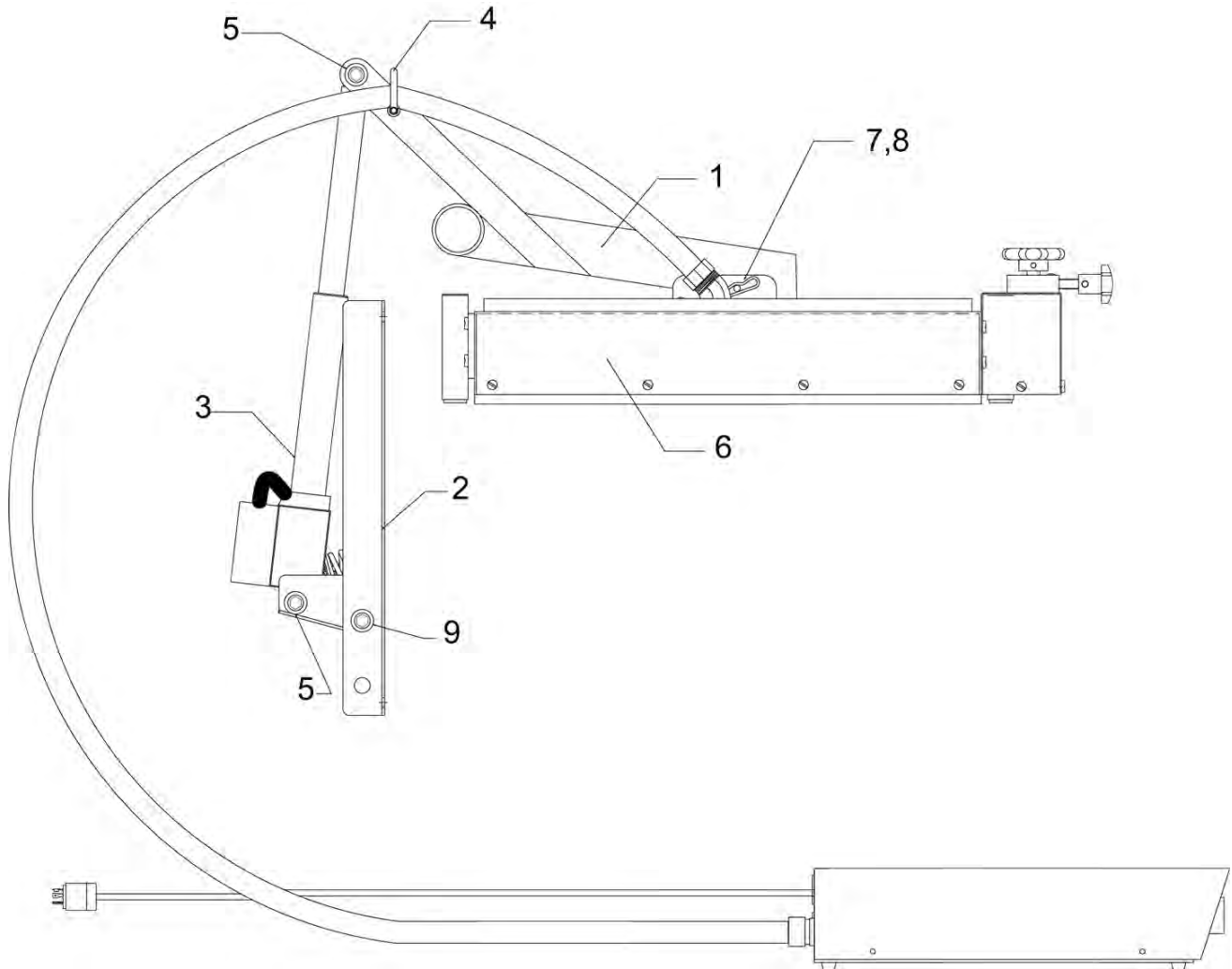

ITEM	DESCRIPTION	QTY.	PART NUMBER
1	TOP-SIDE COOKER WELD. AUTO NEW ARM	1	052115
2	AUTO TOP SIDE A0-2 ACTUATOR MTG.	1	053991
3	ACTUATOR AUTO TOPSIDE COOKER 24V	1	060463
4	TOP-SIDE CONDUIT SUPPORT	1	052287
5	TOP-SIDE COOKER LIFT ARM ROD	2	052117
6	TOP-SIDE COOKER HEAD W/ CONDUIT AND CONTROL PANEL	1	---
7	$\frac{3}{8}$ " - 2 $\frac{1}{2}$ " CLEVIS PIN	1	015164
8	COTTER PIN $\frac{5}{16}$ " - $\frac{3}{8}$ " : 0.72 WIRE	2	015165
9	TOP-SIDE COOKER LIFT ARM ROD	1	052591

## INSTRUCTIONS FOR MICROSWITCH ADJUSTMENT AUTO-LIFT TOP-SIDE™ ACTUATOR

Figure 6-3

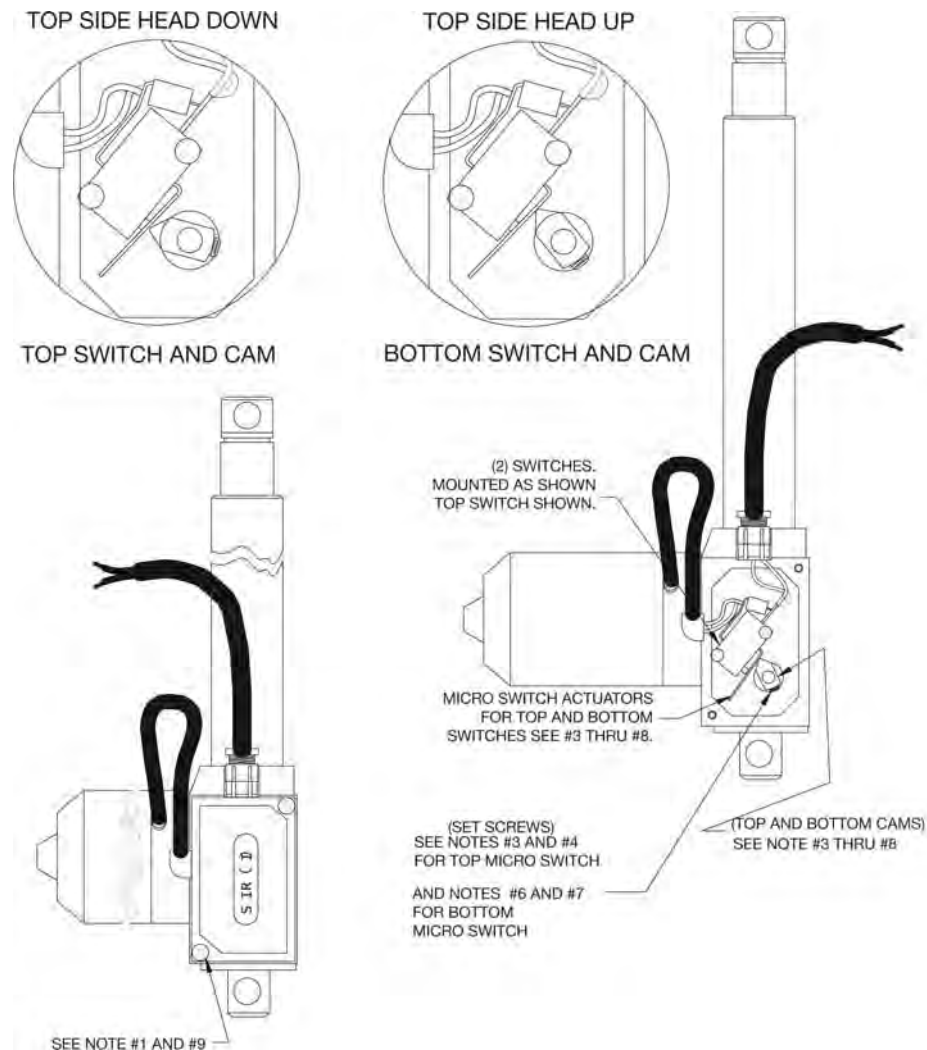

1. Remove the limit switch black plastic cover on the actuator.
2. Turn on the power on unit and push the T1, T2 or T3 button on the timer. The actuator will extend the stroke and lower head. The motor must stop and the stroke should stop extending before it reaches its mechanical stop. This movement is controlled by the top micro switch.
3. If the motor fails to stop, manually depress the top micro switch actuator. Disconnect power to the actuator motor. Loosen the set screw (2.5mm allen wrench) located on the top cam. Rotate the top cam clockwise, until the switch is made (listen for audible click).
4. Tighten the set screw on the cam, using blue locktite.
5. Turn on the power and push the T1, T2 or T3 button on the timer until it goes to the preset time. The actuator will retract the stroke and raise the head. The motor must stop

and the stroke should stop retracting before it reaches its mechanical stop. This movement is controlled by the bottom micro switch.

6. If the motor fails to stop, manually depress the bottom micro switch actuator. This will disconnect power to the actuator motor. Loosen the set screw (2.5mm Allen wrench) located on the bottom cam. Rotate the bottom cam counter clockwise until the switch is made (listen for audible click.).
7. Tighten the set screw on the cam, using blue locktite.
8. Test the Top-Side head. Verify the adjustments did not change the length of the stroke, thus preventing correct function of the top Top-Side head. The Top-Side cooking head must be able to reach the griddle plate. If it does not function properly, complete steps #2 through #7.
9. Reinstall the switch cover.

# TOP-SIDE™ COOKER CONTROL PANEL

Figure 6-4

ITEM	DESCRIPTION	QTY.	PART NUMBER
1	THERMOSTAT	1	056840
	THERMOSTAT REPLACEMENT KIT FOR PRE 2005 MODELS	1	057138
2	HI-LIMIT CONTROL	1	010311
3	HI-LIMIT MOUNTING BRACKET	1	016654
4	CONTACTOR, 50A, 3 POLE	1	011184
5	ROCKER SWITCH, LIGHTED, ON/OFF	1	016689
6	INSTRUCTION PLATE ON/OFF SWITCH PLATE	1	016672
7	INDICATING LIGHT, ELEMENT ON, RED 250V	1	036933
	INDICATING LIGHT, ROUND RED 220V (Effective 8/31/10)	1	002495
8	INSTRUCTION PLATE ELEMENT ON LIGHT PLATE	1	016673
9	TERMINAL BLOCK 3 POLE	1	002565
10	CORD 9' 12/3 SJO	1	018480
11	GROUND LUG 1/4"	1	028510
12	CONDUIT 65" COMPLETE WITH WIRES	1	034431
13	CONNECTOR 1/2" LIQUID TIGHT 45°	1	031584
14	CONNECTOR 1/2" LIQUID TIGHT STRAIGHT	1	031586
15	PLUG 30 AMP 250V 3W 2 POLE	1	020068

## Top View with Cover Removed

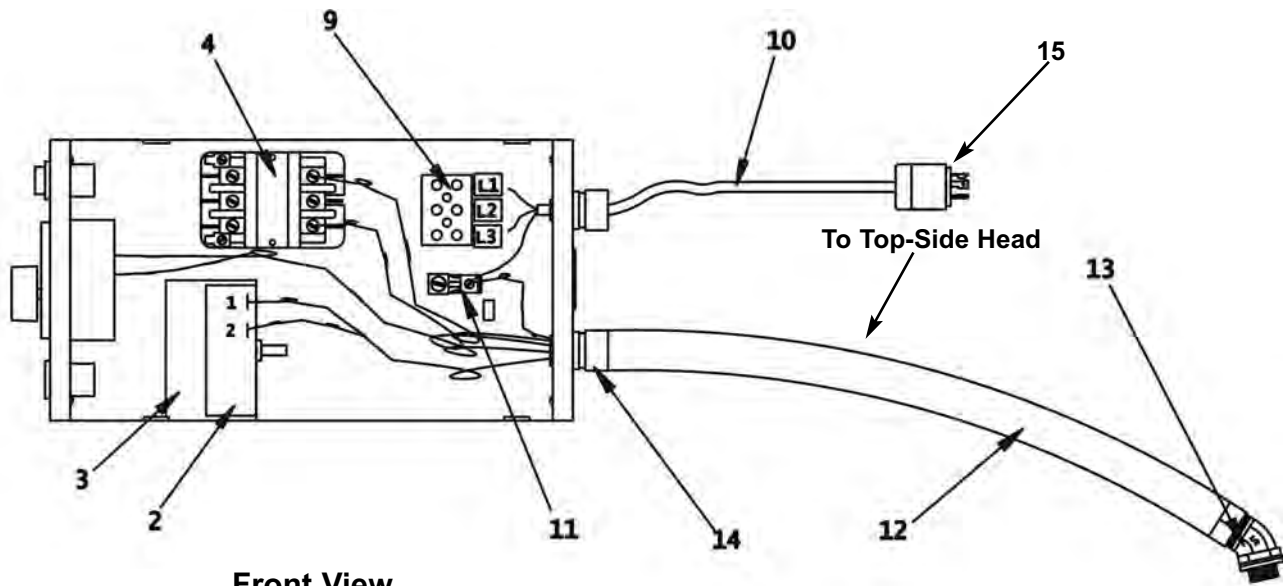

## Front View

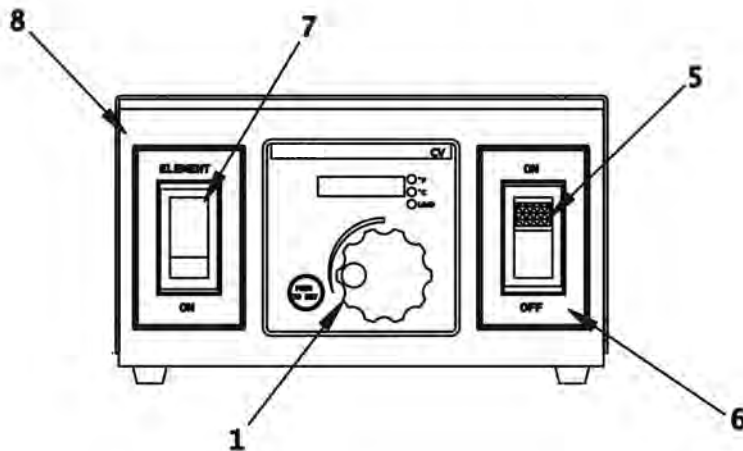

# TOP-SIDE™ COOKER POWER SUPPLY BOX FOR AUTO-LIFT ACTUATORS WITH DIGITAL TIMER - 120VAC SUPPLY

Figure 6-5

ITEM	DESCRIPTION	QTY.	PART NUMBER
1	TRANSFORMER STEPDOWN 24VAC 75VA	1	056037
2	RELAY DPDT 24VAC	1	030844
3	RECTIFIER 24VDC	1	018321
4	CIRCUIT BREAKER 3A 1 POLE 250V	1	053338
5	CORD POWER 6'	1	033559

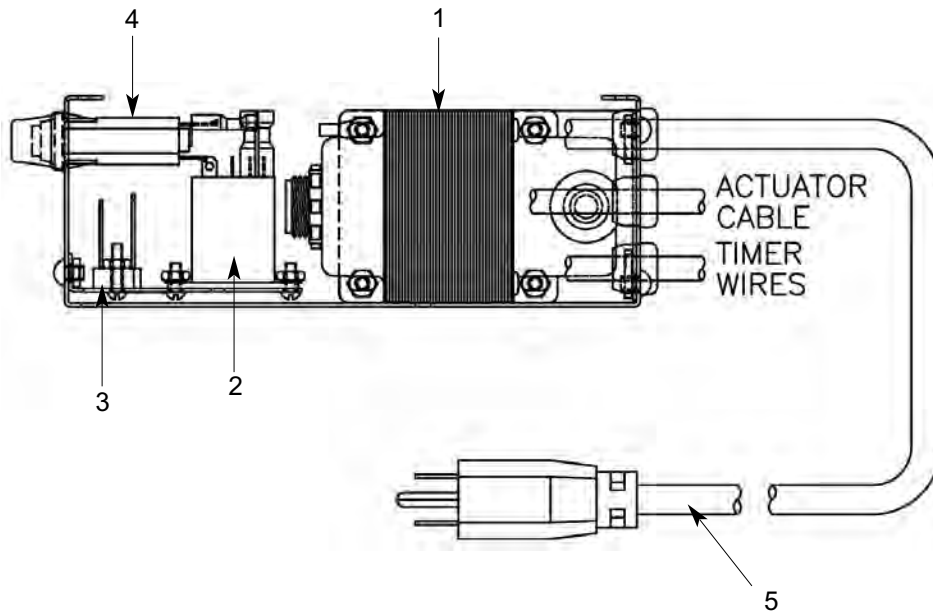

## WIRING DIAGRAM

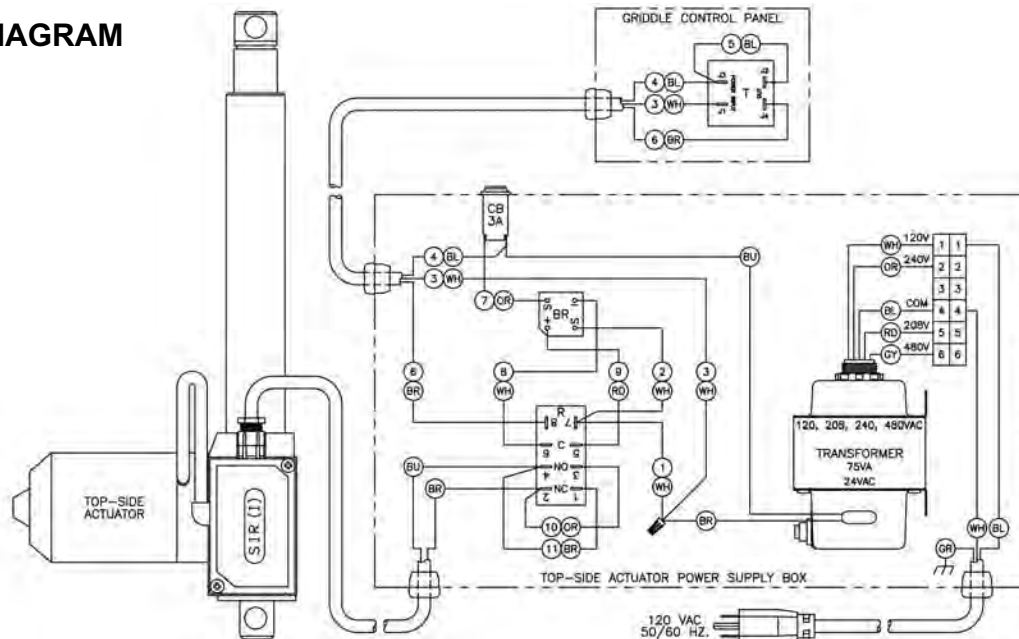

**WIRE COLOR CODES:**  
 RD - RED  
 BL - BLACK  
 BR - BROWN  
 BU - BLUE  
 GR - GREEN  
 GY - GRAY  
 OR - ORANGE  
 WH - WHITE  
  
**COMPONENT CODES:**  
 CB - CIRCUIT BREAKER  
 BR - BRIDGE RECTIFIER  
 R - RELAY 24VAC  
 T - TIMER  
  
 NOTE: ALL WIRES ARE 18 AWG.

# TOP-SIDE™ COOKER POWER SUPPLY BOX FOR AUTO-LIFT ACTUATORS WITH DIGITAL TIMER - 240VAC SUPPLY

Figure 6-6

ITEM	DESCRIPTION	QTY.	PART NUMBER
1	TRANSFORMER STEPDOWN 24VAC 75VA	1	056037
2	RELAY DPDT 24VAC	1	030844
3	RECTIFIER 24VDC	1	018321
4	CIRCUIT BREAKER 3A 1 POLE 250V	1	053338
5	CORD POWER 9' 220V	1	020833

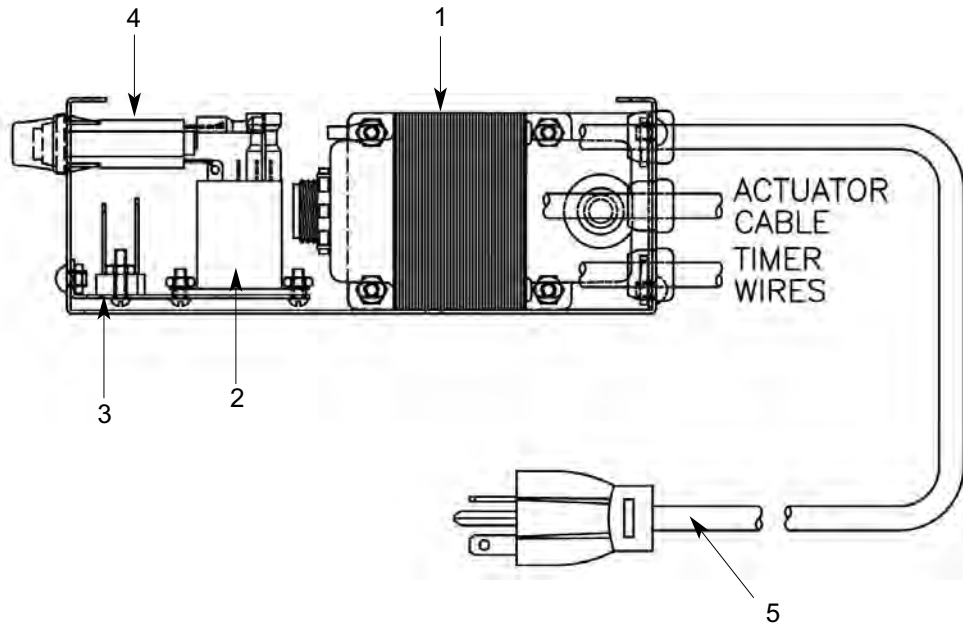

## WIRING DIAGRAM

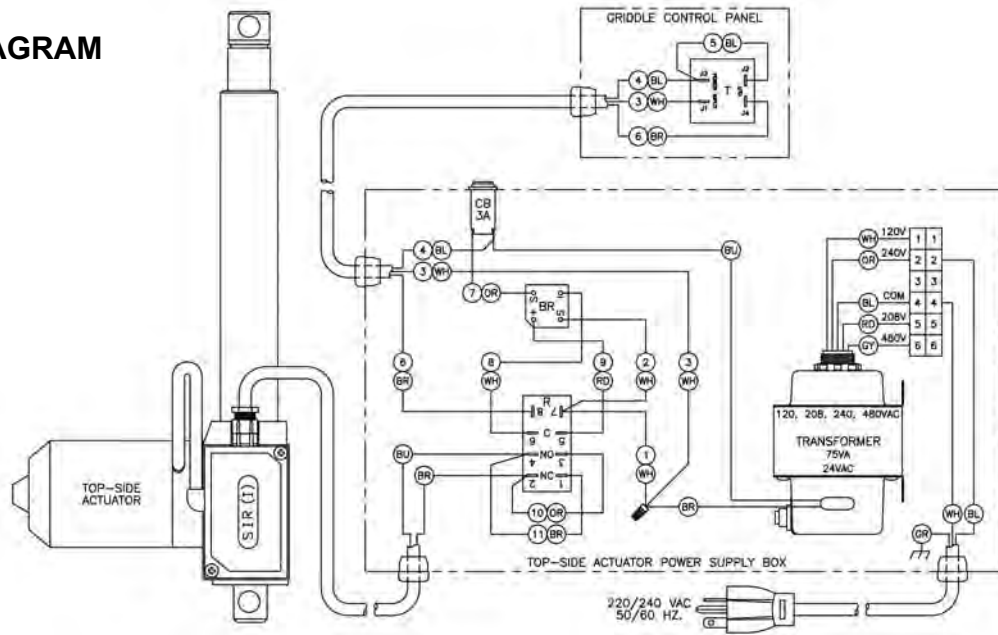

**WIRE COLOR CODES:**  
 RD - RED  
 BL - BLACK  
 BR - BROWN  
 BU - BLUE  
 GR - GREEN  
 GY - GRAY  
 OR - ORANGE  
 WH - WHITE  
  
**COMPONENT CODES:**  
 CB - CIRCUIT BREAKER  
 BR - BRIDGE RECTIFIER  
 R - RELAY 24VAC  
 T - TIMER  
  
 NOTE: ALL WIRES ARE 18 AWG.



# VII WIRING DIAGRAM

## TOP-SIDE™ COOKER MANUAL LIFT WIRING DIAGRAM

Figure 6-7

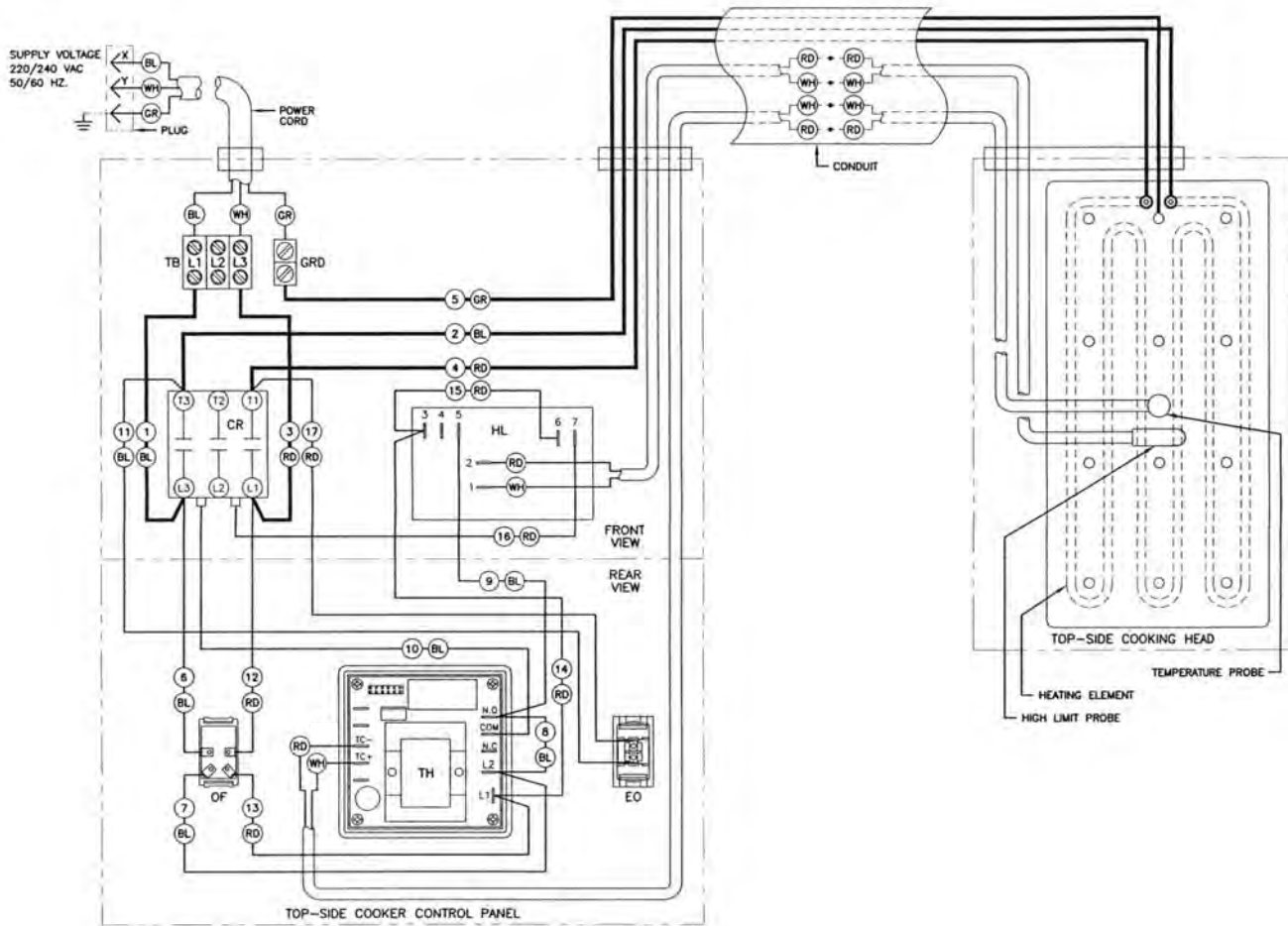

LIGHTED ROCKER ON/OFF SWITCH GREEN LIGHT ON TOP OR LIGHTED ROCKER ON/OFF SWITCH GREEN LIGHT ON BOTTOM

NOTE: ANGLED TERMINALS OF SWITCH ARE ALWAYS TOWARD CONTROL PANEL BOTTOM.

- NOTES:  
 1. ——— = 12 AWG WIRE.  
 2. ALL OTHER WIRES ARE 18 AWG.

COMPONENT CODES:  
 CR - CONTACTOR 220/240VAC  
 EO - "ELEMENT ON" LIGHT (RED)  
 GND - GROUNDING LUG  
 HL - HIGH LIMIT  
 OF - "ON / OFF" SWITCH, LIGHTED (GREEN)  
 R - RELAY  
 TB - TERMINAL BLOCK  
 TH - THERMOSTAT

WIRE COLOR CODES:  
 BL - BLACK  
 GR - GREEN  
 RD - RED  
 WH - WHITE

# TOP-SIDE™ COOKER AUTO-LIFT WIRING DIAGRAM FOR GAS GRIDDLE

Figure 6-8

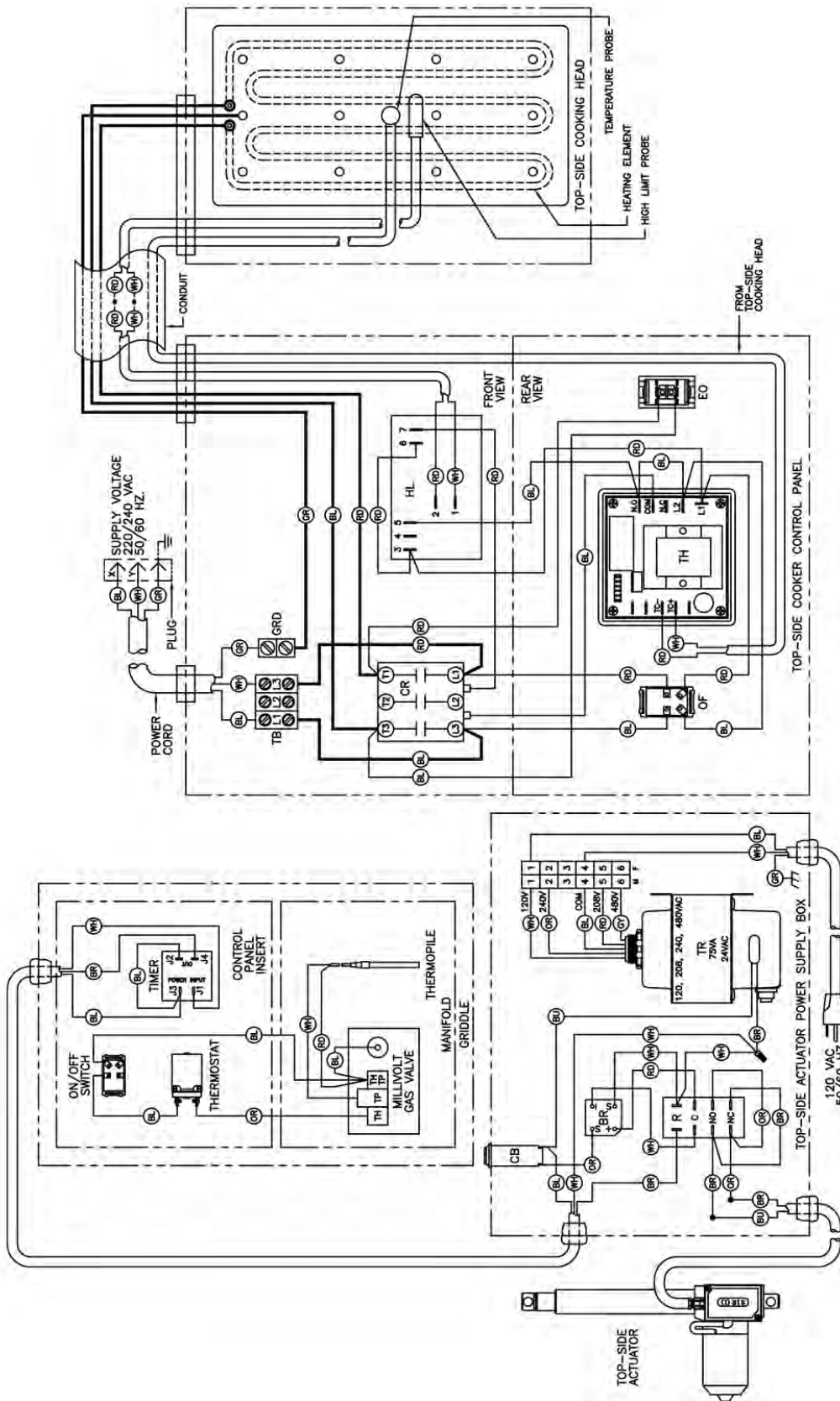

<p><b>COMPONENT CODES:</b></p> <ul style="list-style-type: none"> <li>BR - BRIDGE RECTIFIER</li> <li>CB - CIRCUIT BREAKER</li> <li>CR - CONTACTOR 220/240VAC</li> <li>GR - GROUNDING LUG (RED)</li> <li>HL - HIGH LIMIT</li> </ul>	<p><b>WIRE COLOR CODES:</b></p> <ul style="list-style-type: none"> <li>BL - BLACK</li> <li>RD - RED</li> <li>GR - GREEN</li> <li>WH - WHITE</li> <li>BR - BROWN</li> <li>OR - ORANGE</li> <li>BU - BLUE</li> </ul>
<p><b>NOTES:</b></p> <ol style="list-style-type: none"> <li>1. — = 12 AWG WIRE.</li> <li>2. ALL OTHER WIRES ARE 18 AWG.</li> </ol>	<p><b>COMPONENT CODES:</b></p> <ul style="list-style-type: none"> <li>OF - "ON/OFF" SWITCH, LIGHTED (GREEN)</li> <li>R - RELAY</li> <li>TB - TERMINAL BLOCK</li> <li>TR - THERMOSTAT</li> <li>TR - TRANSFORMER</li> </ul>

# TOP-SIDE™ COOKER AUTO-LIFT WIRING DIAGRAM FOR ELECTRIC GRIDDLE 208 - 240VOLT

Figure 6-9

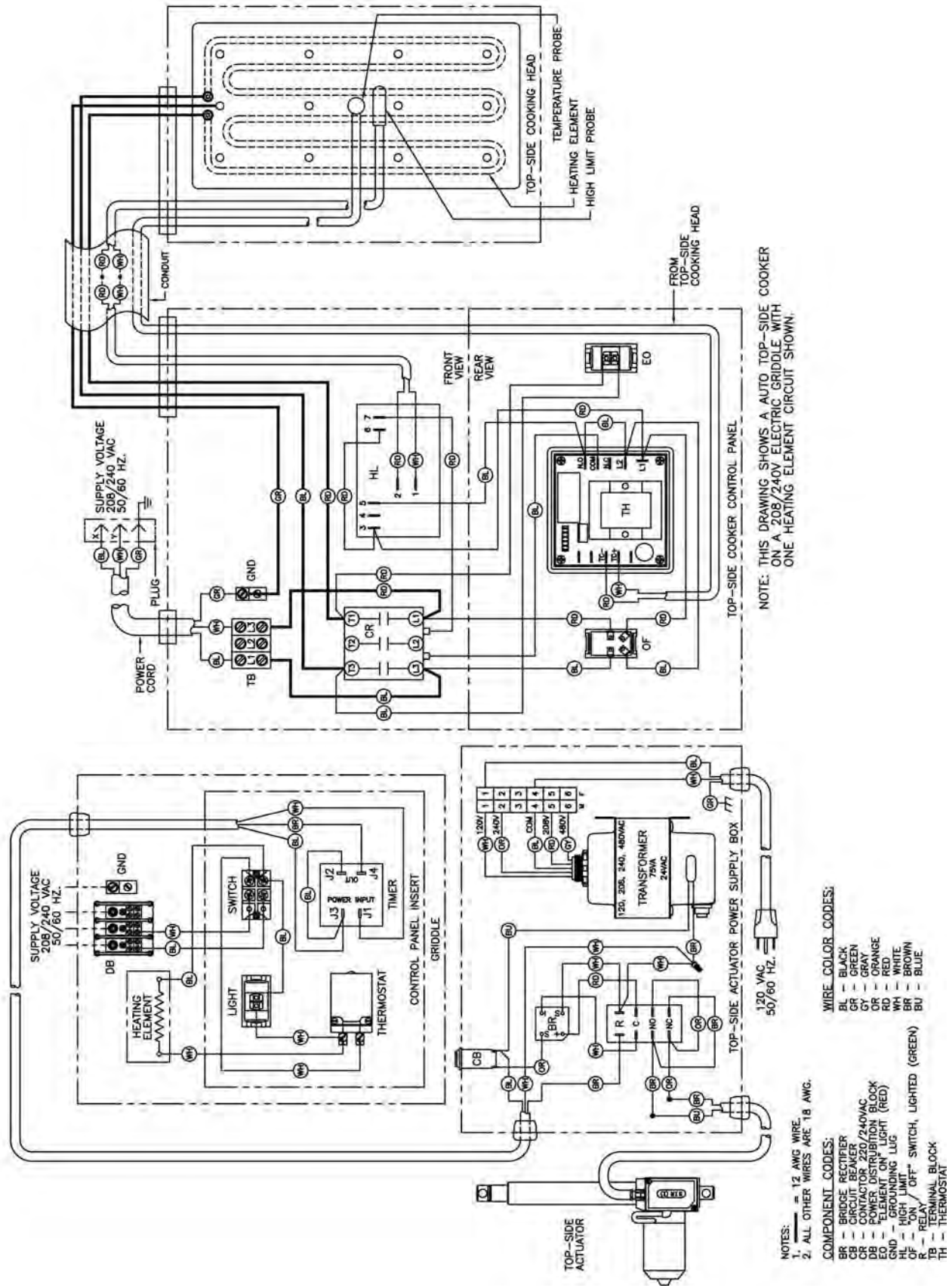

# TOP-SIDE™ COOKER AUTO-LIFT WIRING DIAGRAM FOR ELECTRIC GRIDDLE 480VOLT

Figure 6-10

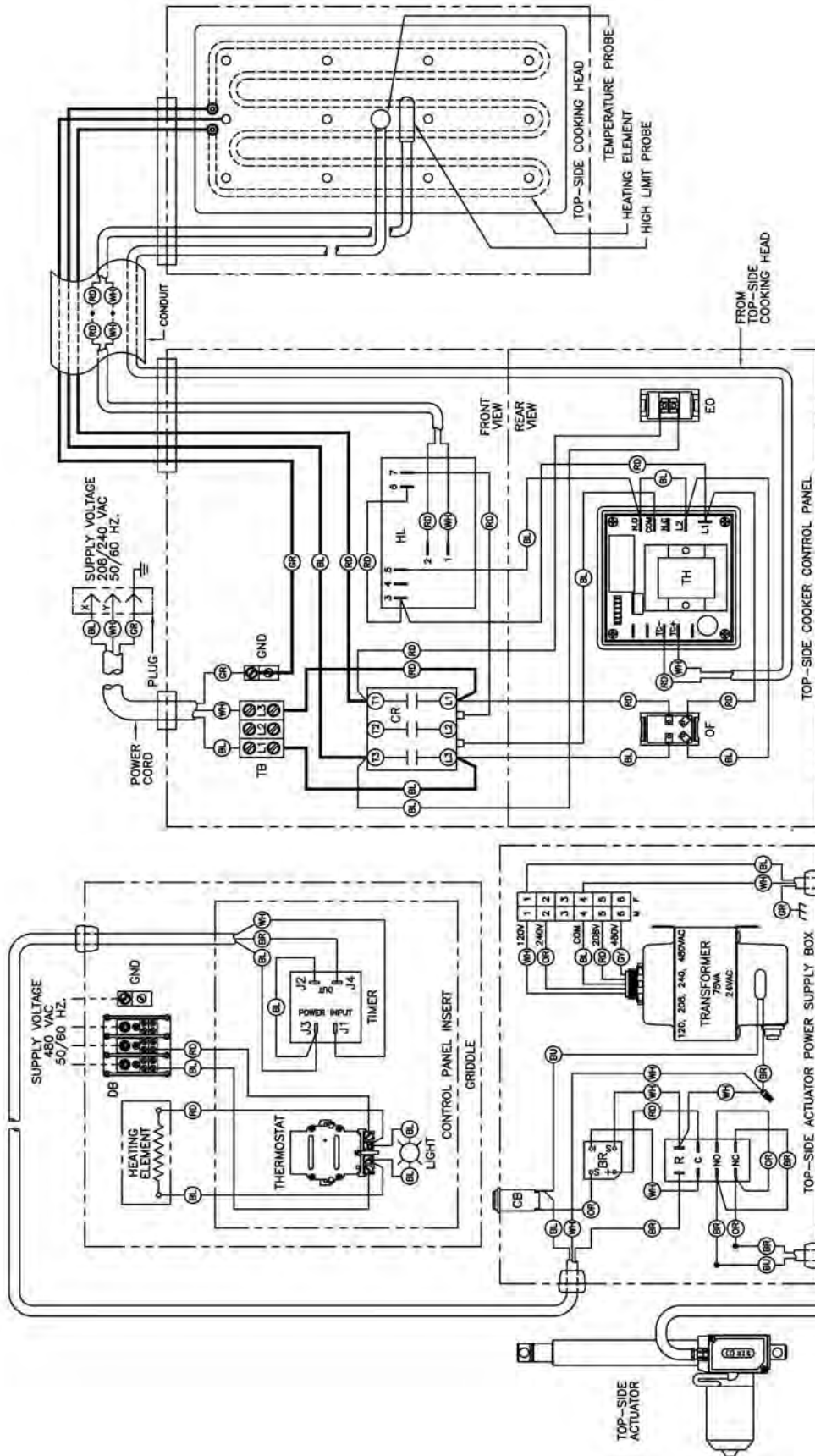

NOTE: THIS DRAWING SHOWS A AUTO TOP-SIDE COOKER ON A 480V ELECTRIC GRIDDLE WITH ONE HEATING ELEMENT CIRCUIT SHOWN.

- NOTES:  
 1. — 12 AWG WIRE  
 2. ALL OTHER WIRES ARE 18 AWG.
- COMPONENT CODES:  
 BR — BRIDGE RECTIFIER  
 CB — CIRCUIT BREAKER  
 CR — CONTACTOR 220/240VAC  
 DB — POWER DISTRIBUTION BLOCK  
 ED — ELEMENT ON LIGHT (RED)  
 GND — GROUNDING LUG  
 HL — HIGH LIMIT  
 R — RELAY  
 ON / OFF SWITCH, LIGHTED (GREEN)  
 TB — TERMINAL BLOCK  
 TH — THERMOSTAT

- WIRE COLOR CODES:  
 BL — BLACK  
 GR — GREEN  
 GY — GRAY  
 OR — ORANGE  
 RD — RED  
 WH — WHITE  
 BR — BROWN  
 BU — BLUE



# WARRANTY

## LIMITED WARRANTY

Keating of Chicago, Inc. ("Keating") warrants to the original purchaser. ("Customer"), all new Keating Fryers, Filter Systems, Griddles, Keep Krisp®, Custom Pasta Systems, Top-Side™ Cookers, Computer Timers, Fryer & Pasta Vessels and Keating replacement parts ("products") installed after June 1, 1994 to be free of defects in material or workmanship, subject to the following terms and conditions.

## LENGTH OF WARRANTY

All products other than Fryer & Pasta Vessels and replacement parts shall be warranted for a period of one year from the date of original equipment installation. Keating replacement parts are warranted for a period of ninety days from the date of installation. Fryer & Pasta Vessels are warranted as described below.

## FRYER & PASTA VESSEL WARRANTY

Fryers purchased after June 1, 1994 carry a prorated vessel warranty on defects in materials or workmanship to the Customer based on the following scale:

Time from Installation Date	Fryer Vessel Warranty Credit
13-60 months	100%
61-72 months	80%
73-84 months	60%
85-96 months	40%
97-108 months	20%
109-120 months	10%

The credit for the defective fryer & pasta vessel shall be applied against the cost of the replacement vessel, utilizing Keating's then current price, upon return of the vessel to Keating, (freight to be paid by Keating within the first 2 months only), only during the first 60 months, subject to the limitations described below.

## LIMITATIONS OF LIABILITY

In the event of warranty claim or otherwise, the sole obligation of Keating shall be the repair and / or replacement at the option of Keating of the product or component or part thereof. Such repair or replacement shall be at the expense of Keating except that the Customer shall pay the following expenses: all freight and labor expense for Keating replacement parts; for all other products, mileage exceeding 50 miles or travel more than one hour, labor costs of more than one person, overtime rates, truck charges, difference between ground and other mode of transportation, and holiday charges. Any repair or replacement under this Limited Warranty does not constitute an extension of the original warranty for any period for the product or for any component or part thereof. Parts to be replaced under this Limited Warranty will be repaired at the option of Keating with new or functionally operative parts. Keep Krisps and Computer Timers must be returned to Keating for warranty repair or replacement. Field repairs of those items are not authorized.

THE LIABILITY OF KEATING ON ANY CLAIM OF ANY KIND, INCLUDING CLAIMS BASED ON WARRANTY, EXPRESSED OR IMPLIED, CONTRACT, NEGLIGENCE, STRICT LIABILITY OR ANY OTHER THEORIES SHALL BE SOLELY AND EXCLUSIVELY THE REPAIR OR REPLACEMENT OF THE PRODUCT AS STATED HEREIN, AND SUCH LIABILITY SHALL NOT INCLUDE, AND CUSTOMER SPECIFICALLY RENOUNCES ANY RIGHTS TO RECOVER, SPECIAL, INCIDENTAL, CONSEQUENTIAL OR OTHER INJURIES TO PERSONS OR DAMAGE TO PROPERTY, LOSS OF PROFITS OR ANTICIPATED PROFITS, OR LOSS OF USE OF THE PRODUCT.

If any oral statements have been made regarding the Keating products, such statements do not constitute warranties and are not part of the contract sale. This Limited Warranty constitutes the complete, final and exclusive statement with regard to warranties.

THIS LIMITED WARRANTY IS EXCLUSIVE AND IS IN LIEU OF ALL OTHER WARRANTIES WHETHER WRITTEN, ORAL, STATUTORY OR IMPLIED, INCLUDING BUT NOT LIMITED TO ANY WARRANTY OF MERCHANTABILITY OR FITNESS FOR PARTICULAR PURPOSE OR WARRANTY AGAINST LATENT DEFECTS.

## EXCLUSIONS

The warranties provided by Keating of Chicago, Inc. do not apply in the following instances:

1. Defects arising out of or resulting from improper installation or maintenance, abuse, misuse, modification or alteration by unauthorized service personnel, or any other condition not attributable to a defect in material or workmanship. Proper installation and maintenance are the responsibility of the installer and Customer, respectively. Proper installation and maintenance procedures are prescribed by the Keating Service Manual.
2. In the event that the product was damaged after leaving the factory due to flood, fire, other acts of God or accident, damage during shipment should be reported to the carrier and is not the responsibility of Keating.
3. In the event the serial number or rating plate has been removed from the product or altered.
4. On parts which would normally be worn or replaced under normal conditions, including but not limited to electric bulbs, fuses, interior and exterior finishes, gaskets and radiants.
5. With regard to adjustments and calibrations such as leveling, tightening of fasteners or plumbing connections, improper gas pressure or improper electrical supply, the checking of and changes in adjustment and calibrations are the responsibility of the installer. Proper installation procedures are prescribed by the Keating Service Manual.
6. In the event of unauthorized repairs or alterations to the Keating product.
7. With the use of sodium chloride in pasta vessels or harsh chemicals in fryer or pasta vessels.
8. Installation in Household.

## OTHER TERMS AND CONDITIONS

The Customer must provide proof of purchase from Keating.

This Limited Warranty is valid in the 50 United States, its territories, and Canada, and is void elsewhere.

Keating products are sold for commercial use only. If any Keating product is sold as a component of another product or used as a consumer product, such Keating product is sold As Is without any warranty.

If any provision of this Limited Warranty is held to be unenforceable under the law of any jurisdiction, such provision shall be inapplicable in such jurisdiction, and the remainder of the warranty shall remain unaffected. Further in such event, the maximum exclusion or limitation allowable under applicable law shall be deemed substituted for the unenforceable provision.

This Limited Warranty shall be governed by and construed in accordance with the laws of the State of Illinois.

## TO SECURE WARRANTY SERVICE

All repair services under this Limited Warranty must be authorized by Keating or performed at Keating. Authorization may be obtained by calling 1-800-KEATING within the Continental United States, Alaska, Hawaii, Puerto Rico and Canada during normal business hours (8 a.m. through 5 p.m. Central Time, Monday through Friday). When calling, please have the following information available: (1) name, address and telephone number of the Customer; (2) location of product; if different; (3) name, model number and serial number of the product; (4) installation date; and (5) description of defect. Keating will then issue a service authorization work order number to one of its approved independent servicing organizations, or request the product or part be shipped to Keating for repair or replacement, as appropriate. Any defective part subject to a claim under this Limited Warranty must be shipped freight prepaid to Keating for testing and examination. Keating's decision as to the cause and nature of any defect under this Limited Warranty shall be final.

**SERVICE INFORMATION**

If you have a service related question call 1-800-KEATING.

Please state the nature of the call; it will ensure speaking with the appropriate person.

Have your serial and model number available when ordering parts.

**KEATING OF CHICAGO, INC.**

8901 W. 50th Street, McCook, Illinois 60525-6001

Phone: (708) 246-3000 FAX: (708) 246-3100

Toll Free 1-800-KEATING (In U.S. and Canada)

www.keatingofchicago.com

**\*As continuous product improvement occurs, specifications may be changed without notice.**

**KEATING LIMITED WARRANTY CARD**

PLEASE COMPLETE AND MAIL AT ONCE--WARRANTY IS NOT IN EFFECT UNTIL CARD IS RETURNED.  
WARRANTY CARD IS ALSO AVAILABLE TO COMPLETE ON LINE AT YOUR CONVENIENCE.

COMPANY: \_\_\_\_\_

ADDRESS: \_\_\_\_\_

CITY: \_\_\_\_\_ STATE: \_\_\_\_\_ ZIP: \_\_\_\_\_

DEALER: \_\_\_\_\_

DATE OF PURCHASE: \_\_\_\_\_ INVOICE NUMBER: \_\_\_\_\_

SERIAL NUMBER: \_\_\_\_\_  FRYER  FILTER SYSTEM  GRIDDLE

REMARKS: \_\_\_\_\_  TOP-SIDE COOKER  HOT PLATE  PASTA PLUS

I HAVE READ THE INSTALLATION AND OPERATION INSTRUCTIONS.

SIGNED: \_\_\_\_\_ DATE: \_\_\_\_\_

*"Serving Those Who Serve The Very Best"®*