



kitchen think

Instructions for Installation and Use

**Gas Hob
Model G640**

To the Installer

**Before installation fill in the product details on the back cover of this book.
The information can be found on the rating plate.**

To the User

**You must read the instructions prior to installing and using the appliance and
then retain them for future reference.**

CONTENTS

| | |
|---------------------------------|------------|
| Introduction | 3 |
| For Your Safety | 4 |
| Know your Hob | 5 |
| How to use your Hob | 5 |
| Practical Advice | 6 |
| Care and Cleaning | 6 |
| Troubleshooting | 6 |
| Installation | 7-8 |
| Burner and Nozzle Specification | 9 |
| Electrical Connection | 9 |
| After Sales Service | 10 |
| Hotpoint Guarantee | 11 |
| Key Contacts | Back Cover |

Retention of this Instruction Book

This Instruction Book must be kept handy for reference as it contains important details on the safe and proper use of the appliance.

If you sell or pass the appliance to someone else, or move house and leave it behind, make sure this Book is also provided so the new owner can become familiar with the appliance and safety warnings.

If the Book is lost or damaged a copy may be obtained from:
GDA LTD., Morley Way, Peterborough, PE2 9JB

Introduction

Your new hob is guaranteed* and will give lasting service. This guarantee is only applicable if the appliance has been installed in accordance with the installation instructions detailed in this booklet.

To help make best use of your cooking equipment, please read this booklet carefully.

The hob is designed specifically for domestic use and responsibility will not be accepted for use in any other installation.

*** The guarantee is subject to the provisions that the appliance:**

- (a) Has been used solely in accordance with this booklet.**
- (b) Has been properly connected to a suitable supply voltage as stated on the rating plate, attached to the appliance.**
- (c) Has not been subjected to misuse or accident or been modified or repaired by any person other than the manufacturers authorised employee or agent.**
- (d) Has been correctly installed.**



This appliance conforms with the following European Economic Community directives:

- 73/23/EEC of 19/02/73 (Low Voltage) and subsequent modifications;
- 89/336/EEC of 03/05/89 (Electromagnetic Compatibility) and subsequent modifications;
- 90/396/EEC of 29/06/90 (Gas) and subsequent modifications;
- 93/68/EEC of 22/07/93 and subsequent modifications.

For Your Safety

When used properly your appliance is completely safe but as with any electrical product there are certain precautions that must be observed.

PLEASE READ THE BELOW PRECAUTIONS BEFORE USING YOUR APPLIANCE.

To maintain the efficiency and safety of this appliance, we recommend you do the following:

- only call the Service Centres authorised by the manufacturer.
- always use genuine spare parts.

ALWAYS:

- make sure you remove all packaging and dispose of safely.
- check the soundness of the appliance after it has been unpacked.
- make sure you understand the controls before using the appliance.
- keep children away from the appliance during use.
- take care to avoid heat/steam burns when operating the controls.
- make sure the controls are turned off when you have finished cooking and when not in use.
- take care to avoid heat/steam burns when operating the controls.
- disconnect from the power supply, and allow to cool, before cleaning or performing maintenance.
- refer servicing to a qualified appliance service engineer.
- keep the hob clean as a build up of grease or fat from cooking can cause a fire.
- follow the basic principles of food handling and hygiene to prevent the possibility of bacterial growth.
- dry food thoroughly before frying and lower it slowly into the hot oil or fat. Frozen food in particular, will cause frith and spitting if added too quickly.
- keep outside of pans clean and free from streaks of oil or fat.
- place pans centrally over the burner making sure handles are kept away from the edge of the hob and cannot be heated by other burners/pans.
- keep any ventilation slots clear of obstructions.

NEVER:

- attempt to install or repair the appliance without the assistance of qualified personnel.
- store items above the appliance that children may attempt to reach.
- heat up unopened food containers, as pressure can build up causing the container to burst.
- use the appliance to heat up anything other than food.
- use the appliance as a room heater.
- dry any items on the hob.
- install the appliance next to curtains or other soft furnishings.
- allow children to play with or tamper with the controls.
- leave children unsupervised where cooking appliances are installed as all the cooking surfaces get hot during and after use.
- store chemicals, foodstuffs or pressurised containers in or on the appliance, or in cabinets immediately above or next to the appliance.
- use flammable or plastic items on or near the hob.
- use adapters, multiple sockets and/or extension leads.
- fill a deep fat frying pan more than 1/3 full of oil, or use a lid. **DO NOT LEAVE UNATTENDED WHILE COOKING.**
- fry too much food at a time, especially frozen food. This only lowers the temperature or the oil or fat too much, resulting in greasy food.
- pull on the appliance or the supply able to unplug it from the electrical outlet.
- allow power cables of other appliances to come into contact.
- with hot parts of this appliance.
- expose the appliance to atmospheric agents, such as rain or sunlight.
- operate the appliance with wet hands.
- allow anyone to sit or stand on any part of the appliance.
- use misshapen pan which may be unstable.
- use round base woks directly on the pan supports.
- use fish kettles or large preserving pans across two burners.

SAFETY ADVICE

IMPORTANT - As with any cooking appliance there could be some fire risk attached to the heating of oil, particularly for deep fat frying. Cooking utensils containing oil must not be left unattended (eg. to answer the telephone) on or in close proximity to the cooking areas.

IN THE EVENT OF A CHIP PAN OR ANY OTHER PAN FIRE:

1. Turn off the burners.
2. Cover the pan with a fire blanket or damp cloth, this will smother the flames and extinguish the fire.
3. Leave the pan to cool for at least 60 minutes before moving it. Injuries are often caused by picking up a hot pan and rushing outside with it.

NEVER USE A FIRE EXTINGUISHER TO PUT OUT A PAN FIRE as the force of the extinguisher is likely to tip the pan over. Never use water to extinguish oil or fat fires.

Know your Hob

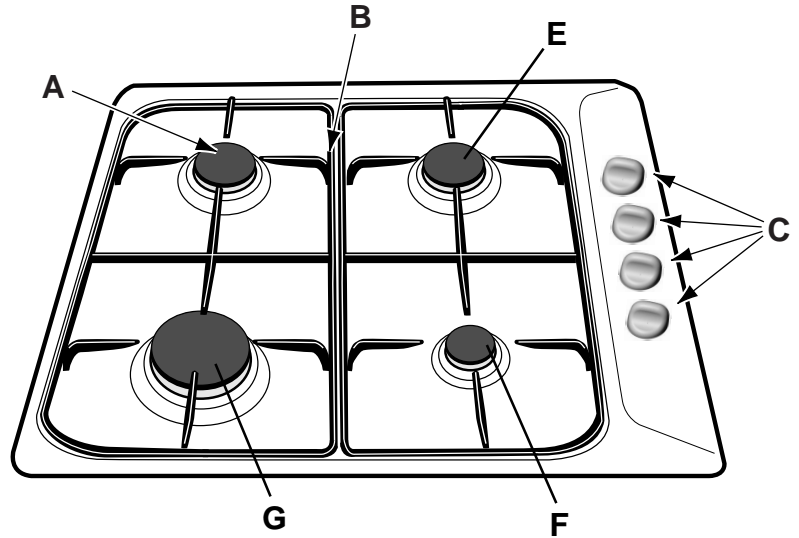
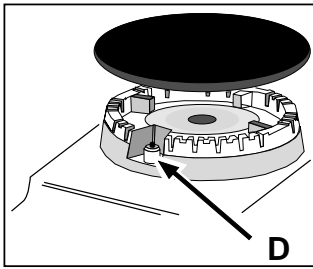

- B. Pan Support for Cookware
- C. Control Knobs for Gas Burners
- D. Ignitor for Gas Burners

- A. Semi-Rapid Gas Burner
- E. Semi-Rapid Gas Burner
- F. Auxillary Gas Burner
- G. Rapid Gas Burner

How To Use Your Hob

The position of the corresponding gas burner is indicated on each control knob.

Gas Burners

The burners differ in size and power. Choose the most appropriate one for the diameter of the cookware being used.

The burner can be regulated with the corresponding control knob by using one of the following settings:

- Off
- 🔥 High
- 🔥 Low

Models fitted with an ignitor (D), (the ☆ symbol is located near each knob):

To light a burner, simply press the corresponding knob all the way in and then turn it in the counter-clockwise direction to the "High" setting, keeping it pressed in until the burner lights.

Caution: If the burner accidentally goes out, turn off the gas with the control knob and try to light it again after waiting at least 1 minute.

To turn off a burner, turn the knob in the clockwise direction until it stops (it should be on the "•" setting).

Practical Advice

Practical Advice on Using the Burners

For best performance, follow these general guidelines:

- Use the appropriate cookware for each burner (see table) in order to prevent the flame from reaching the sides of the pot or pan;
- Always use cookware with a flat bottom and keep the lid on;
- When the contents come to a boil, turn the knob to "Low".

| Burner | ∅ Cookware diameter (cm) |
|----------------|--------------------------|
| Rapid (R) | 24 - 26 |
| Semi-Rapid (S) | 16 - 20 |
| Auxiliary (A) | 10 - 14 |

Care and Cleaning

Before cleaning or performing maintenance on your hob, disconnect it from the power supply.

To extend the life of the hob, it should be cleaned carefully and thoroughly on a frequent basis, keeping in mind the following:

- The enameled parts must be washed with warm water without using abrasive powders or corrosive substances which could ruin them;
- The removable parts of the burners should be washed frequently with warm water and soap, making sure to remove caked-on substances;
- On hobs with automatic ignition, the end of the electronic ignition device must be cleaned carefully and frequently, making sure that the gas holes are not clogged;

- Stainless steel can be stained if it remains in contact with highly calcareous water or aggressive detergents (containing phosphorous) for an extended period of time. It is recommended that these parts be rinsed thoroughly with water and then dried well. It is also a good idea to clean up any spills.

Greasing the Gas Valves

Over time, the gas valves may stick or become difficult to turn. If this is the case, they must be cleaned on the inside and the greased.

N.B.: This procedure must be performed by a technician authorized by the manufacturer.

Troubleshooting

Before calling service for assistance, check through the following list, there may be nothing wrong.

First of all, check to see that there are no interruptions in the gas and electrical supplies, and, in particular, that the gas valves for the mains are open.

If the burner does not light or the flame is not uniform around the burner.

Check to make sure that:

- The gas holes on the burner are not clogged;
- All of the movable parts that make up the burner are mounted correctly;
- There are no draughts around the cooking surface.

If the flame does not stay lit.

Check to make sure that:

- You press the knob all the way in;
- You keep the knob pressed in long enough to activate the safety device.
- The gas holes are not clogged in the area corresponding to the safety device.

If the burner does not remain on when set to "Low".

Check to make sure that:

- The gas holes are not clogged.
- There are no draughts near the cooking surface.
- The minimum has been adjusted correctly (see Installation section, "Minimum Regulation").

If the cookware is not stable.

Check to make sure that:

- The bottom of the cookware is perfectly flat.
- The cookware is centered correctly on the burner.
- The support grids have not been inverted.

If, despite all of these checks, the hob does not function properly and problem persists, call Hotpoint Service (see KEY CONTACTS, back page), informing them of:

- The type of problem.
- The abbreviation used to identify the model (Mod. ...) as indicated on the warranty.

IMPORTANT:

Never call upon technicians not authorized by the manufacturer, and refuse to accept spare parts that are not original.

Installation Instructions for your built-in Hob

The following instructions are intended for the installer so that the installation and maintenance procedures may be followed in the most professional and expert manner possible. **Important: Disconnect the appliance from the electrical supply before performing any maintenance or regulation upkeep work.**

Positioning for gas hob

Important: this unit may be installed and used only in permanently ventilated rooms according to the British Standards Codes Of Practice: B.S. 6172 / B.S. 5440, Par. 2 and B.S. 6891 Current Editions. The following requirements must be observed:

- The hob must not be installed in a bed sitting room with a volume of less than 20m³. If it is installed in a room of volume less than 5m³ an air vent of effective area of 110cm² is required, if it is installed in a room of volume between 5m³ and 10m³ an air vent of effective airvent of 50cm² is required, while if the volume exceeds 11m³ no airvent is required. However, if the room has a door or a window which opens directly to the outside no air vent is required even with the volume is between 5m³ and 11m³.
- Intensive or prolonged use of the appliance could mean that extra ventilation is needed, such as the opening of a window or a more powerful fan.
- If there are other fuel burning appliances in the same room, B.S. 5440 Part 2 Current Edition, should be consulted to determine the requisite air vent requirements.

Installation of built-in gas hobs

The gas hobs are prepared with protection degree against excessive heating of type X, the appliance can therefore be installed next to cabinets, provided the height does not exceed that of the hob. For a correct installation of the cooking hob the following precautions must be followed:

- The hob may be located in a kitchen, a kitchen/diner or bed sitting room, but not in a bathroom or shower room.
- The furniture standing next to the unit, that is higher than the worktops, must be placed at least 110mm from the edge of the board.
- The minimum distance combustible material can be fitted above the hob in line with the edges of the hob is 420mm. If is fitted below 420mm a space of 50mm must be allowed from the edges of the hob. The minimum distance combustible material kitchen units can be fitted directly above the hob is 700mm.

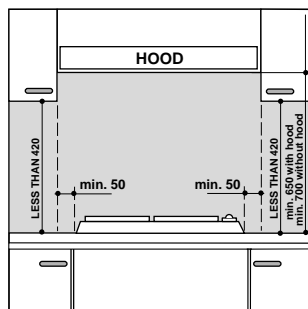
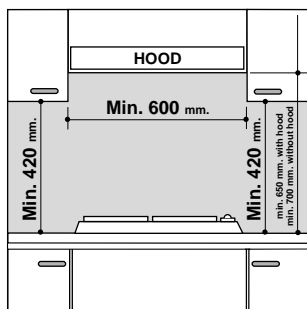

- The dimensions of the room for the furniture must be those indicated in the figures. Fixing hooks are provided which allow to place the hob plate on work tops that measure from 20 to 40 mm in thickness. To obtain a

good fixing of the hob plate it is advisable to use all the hooks supplied.

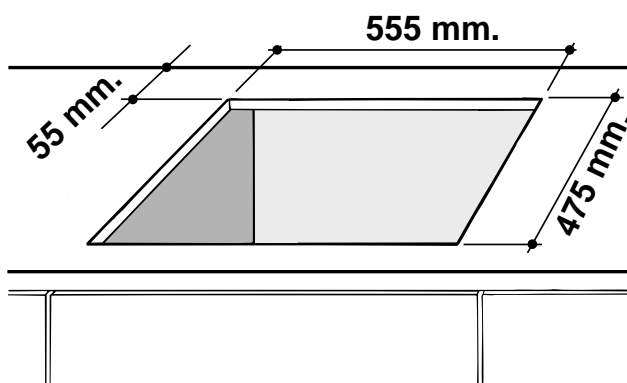

Fastening Clamps - Assembly Diagram

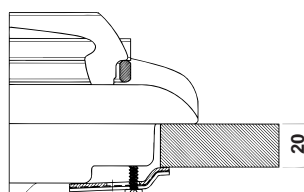

Clamp Position for H=20mm top

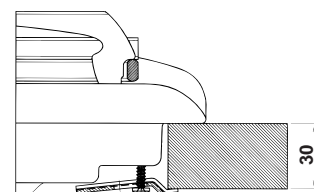

Clamp Position for H=30mm top
Front

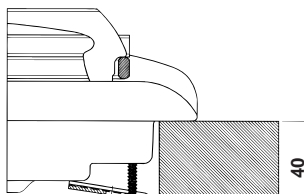

Clamp Position for H=40mm top

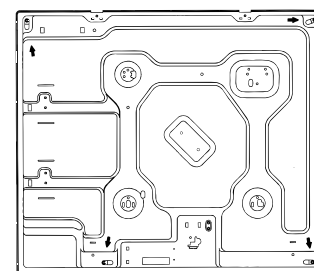

Back

- N.B:** Use the clamps contained in the "accessory kit."
- In the event the hob is not installed above a built-in oven, a wood panel must be inserted as insulation. This panel must be placed at least 20 mm from the bottom of the hob itself.

Important: When installing the hob above a built-in oven, the oven should be placed on two wooden strips; in the case of a joining cabinet surface, remember to leave a space of at least 45 x 560 mm at the back.

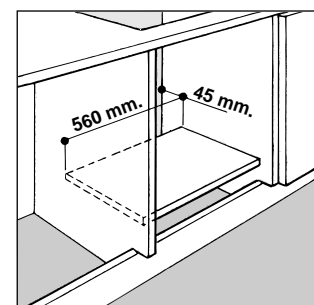
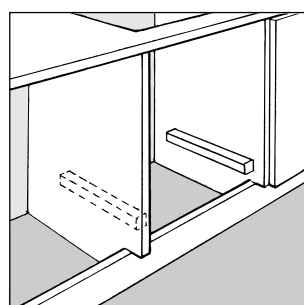

Installation Instructions for your built-in Hob

When installing the hob above a built-in oven without forced ventilation, ensure that there are air inlets and outlets for ventilating the interior of the cabinet adequately.

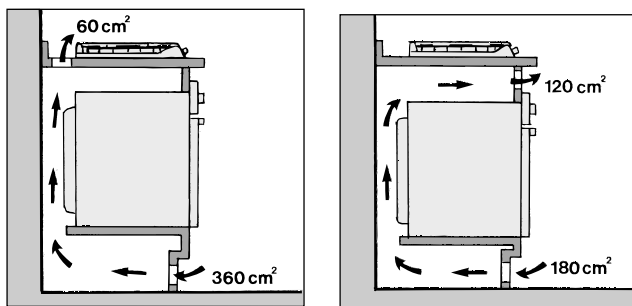

Gas Connection for Cooktop

The hob should be connected to the gas supply by an authorized installer. During installation of this product it is essential to fit an approved gas tap to isolate the supply from the appliance for the convenience of any subsequent removal or servicing. Connection of the appliance to the gas mains or liquid gas tanks must be carried out according to the safety standards currently in force, and only after it is ascertained that it is suitable for the type of gas to be used. If not, follow the instructions indicated in the section entitled, "Adapting the hob for Different Types of Gas". If the hob is to be connected to tanks containing liquid gas, use pressure regulators that comply with current safety standards.

Important: To insure that the appliance operates safely, the gas is regulated correctly and your appliance lasts over time, make sure that gas pressure levels comply with the indications given in Table 1, "Nozzle and Burner Specifications".

Gas Connection to Non-flexible Pipe

(copper or steel)

Connection to the gas source must be done in such a way as to not create any stress points at any part of the appliance.

The appliance is fitted with an adjustable, "L" shaped connector and a gasket for the attachment to the gas supply. Should this connector have to be turned, the gasket must be replaced (supplied with the appliance).

The gas feed connector to the appliance is a threaded, male 1/2" connector for round gas pipe.

Gas Connection to Flexible Steel Pipe

The gas feed connector to the appliance is a threaded, male 1/2" connector for round gas pipe. Only use pipes, tubes and gaskets that comply with current safety codes. The maximum length of the flexible pipes must not exceed 2000 mm. Once the connection has been made, ensure that the flexible metal tube does not touch any moving parts and is not crushed.

Check the Seal

Once the hob has been installed, make sure all the connections are properly sealed, using a soapy water solution. Never use a flame.

Adapting the Hob for Different Types of Gas

To adapt the hob to a different type of gas than that for which it was designed, (see the sticker under the hob or on the packaging), the burner nozzles must be changed, as follows:

- Remove the pan supports and slide the burners out of the hob.
- Unscrew the nozzles using a 7mm socket wrench and replace them with those for the new type of gas. (See Table 1, "Burner and Nozzle Specifications").
- Reassemble the parts following the instructions in reverse order.
- On completing the operation, replace the old rating label with the one showing the new type of gas; the sticker is available from our Hotpoint Service (see KEY CONTACTS, back page).

If the gas pressure is different than that prescribed, a pressure regulator must be installed at the source, in compliance with national standards governing the use of piped gas regulators.

Regulation of Air Supply to the Burner

The burners do not need a primary air regulator.

Minimum Regulation

- Turn the gas valve to minimum.
- Remove the knob and turn the regulator screw (positioned either on the side of the top or inside the shaft) clockwise until the flame becomes small but regular.

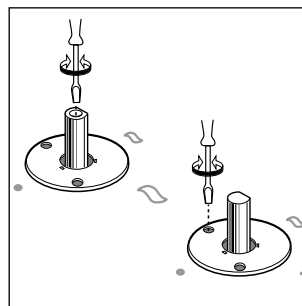

N.B.: In the case of liquid gas, the regulation screw must be fully screwed in (clockwise).

- Make sure that, when the knob is turned rapidly high to low, the flame does not go out.
- In the event of a malfunction on appliances with the security device (thermocouple) when the gas supply is set at minimum, increase the minimum supply levels using the regulator screw.

Once the adjustment has been made, apply sealing wax, or a suitable substitute, to the old seals on the by-pass.

Burners and Nozzle Specifications

| Table 1 | | | | Liquid Gas | | | | Natural Gas | |
|------------------|----------------|----------------------------|--------|--------------------|-------------------|-----------|-----|-------------------|-----------|
| Burner | Diameter (mm) | Thermal power kW (p.c.s.*) | | By-Pass 1/100 (mm) | Nozzle 1/100 (mm) | Flow* g/h | | Nozzle 1/100 (mm) | Flow* l/h |
| | | Nomin. | Ridot. | | | *** | ** | | |
| Fast (R) | 100 | 3,00 | 0,70 | 41 | 86 | 218 | 214 | 116 | 286 |
| Semi Fast (S) | 75 | 1,90 | 0,40 | 30 | 70 | 138 | 136 | 106 | 181 |
| Auxiliary (A) | 55 | 1,00 | 0,40 | 30 | 50 | 73 | 71 | 79 | 95 |
| Supply Pressures | Nominal (mbar) | | | | | 28-30 | 37 | 20 | |
| | Minimum (mbar) | | | | | 20 | 25 | 17 | |
| | Maximum (mbar) | | | | | 35 | 45 | 25 | |

** At 15°C and 1013 mbar-dry gas

** Propane P.C.S. = 50.37 MJ/kg.

*** Butane P.C.S. = 49.47 MJ/kg.

Natural P.C.S. = 37.78 MJ/m³

Gas Section: Class

Rated Power kW (1)

||2H3+

7,8 (567gr/h-G30)

(557gr/h-G31)

(1) Values in g/h refer to capacities with liquid gas (Butane, Propane).

It is the law that all gas appliances are installed by competent persons in accordance with the current edition of the Gas Safety (Installation and Use) Regulations. It is in your interest and that of safety to ensure compliance with the law.

In the UK, CORGI registered installers work to a safe standard of practice.

The hob must be installed in accordance with BS6172:

Failure to install the hob correctly could invalidate the warranty liability claims and could lead to prosecution.

Electrical Connection

Electrical connection

The electrical connection to the mains must be made on the appliance. The power voltage and frequency are as indicated on the rating plate.

WARNING: THIS APPLIANCE MUST BE EARTHED.

CONNECTING TO A 230-240V 50Hz SUPPLY ONLY.

The electrical installation should be carried out in compliance with the current electricity regulations by a qualified electrician. The cable should be routed so that it does not come into contact with the hob base by securing it to the cabinet side or rear wall.

It should be connected to a suitable double pole isolating switch having a contact separation of at least 3mm in all poles placed in a readily accessible position adjacent to the hob.

IMPORTANT:

The wires in the mains lead fitted to this appliance are coloured in accordance with the following code:

| | |
|-------|-----------|
| GREEN | - EARTH |
| BLUE | - NEUTRAL |
| BROWN | - LIVE |



After Sales Service

"No company is better positioned to offer an after sales service on a Hotpoint appliance than us - the manufacturer"

As part of our commitment to you, all Hotpoint appliances have the added benefit of a fully inclusive parts and labour guarantee for the first 12 months. In addition to this you also have the advantage of **free replacement parts for the first 5 years** when fitted by a Hotpoint engineer. When the 12 months parts and labour guarantee expires we offer the following after sales service options:

Repair Service and Information Help Desk

UK: 08709 066066

www.theservicecentre.co.uk

Republic of Ireland: 1850 302 200

Note: Our operators will require the Model number and the Serial number of your appliance

Available 364 days a year with a fast, effective and value for money service. We have the largest white goods repair service in the UK with over 1200 of our own fully trained engineers. All repairs include a parts and labour guarantee for 12 months from the date of the repair.

If you require any information or have any questions about your appliance, our operators are on hand with help and advice.

All this ensures that you will receive the best available after sales service possible.

Extended Warranties

UK: 08709 088 088

www.theservicecentre.co.uk

Republic of Ireland: 1850 502 200

Whether you have just one or a number of Hotpoint appliances in your kitchen, we offer two service cover plans to give you total peace of mind.

- Repair Protection Plan - FREE service repairs for a single Hotpoint appliance during the period of cover.
- Kitchen Cover - FREE service repairs for all your Hotpoint appliances less than 8 years old.

Genuine Parts and Accessories UK: 08709 077 077

www.theservicecentre.co.uk

Republic of Ireland: (01) 842 6836

A wide range of genuine parts and accessories are available from our hotline or through our web site.

Genuine parts and accessories, extended warranties and service repairs are all available on our web-site at:



www.theservicecentre.co.uk



Guarantee

"Satisfaction guaranteed or your money back"

We give you a unique 'satisfaction guaranteed' promise - **valid for 90 days** - after you have purchased your Hotpoint appliance. If there is a technical problem simply call Hotpoint Repair service or visit our web-site at www.theservicecentre.co.uk and where necessary, we will arrange for an engineer to call. If the technical problem is not resolved under this guarantee, **we will replace your machine or, if you prefer, give you your money back.**

All Hotpoint appliances carry a fully inclusive 12 month parts and labour guarantee as well as free replacement parts for the first 5 years (except microwaves, selected integrated appliances and cooker hoods, which have a one year guarantee) provided that they are fitted by a Hotpoint engineer.

Guarantee terms and conditions

Your guarantee is only applicable in the United Kingdom or Republic of Ireland and is subject to the following provisions that your appliance:

- Has been installed and used correctly in accordance with this instruction booklet.
- Has been used solely for domestic purposes and is located on domestic premises (ie. not for commercial or trade use).
- Has been properly connected to a suitable electrical supply voltage as stated on the appliance rating plate.
- Has not been subject to misuse, accident, modified or repaired by anyone other than one of our own service engineers.

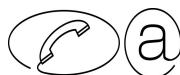

For pre purchase information on any other Hotpoint product call: 08701 50 60 70
or visit: www.hotpoint.co.uk



Recycling & Disposal Information

As part of Hotpoint's continued commitment to helping the environment, Hotpoint reserves the right to use quality recycled components to keep down customer costs and minimise material wastage.

Please dispose of packaging and old appliances carefully.

To minimise risk of injury to children, remove the door, plug and cut mains cable off flush with the appliance. Dispose of these parts separately to ensure that the appliance can no longer be plugged into a mains socket, and the door cannot be locked shut.



Key Contacts

After Sales Service

Over 1200 trained specialists, directly employed by us, ensure that you can have complete confidence in both the appliances and services we offer.



Repair Service and Information Desk

UK: 08709 066 066

(Open 8 to 8 Mon - Fri, 8 to 6 Sat, 10 to 4 Sun & Bank Holidays)

www.theservicecentre.co.uk

Republic of Ireland: 1850 302 200

Note: Our operators will require the following information:

Model number:

Serial number:

Extended Warranties

UK: 08709 088 088

(Open 8 to 8 Mon - Sun)

www.theservicecentre.co.uk

Republic of Ireland: 1850 502 200

Genuine Parts and Accessories

UK: 08709 077 077

(Open 8-30 to 5-30 Mon - Fri & 9 to 12 Sat)

www.theservicecentre.co.uk

Republic of Ireland: (01) 842 6836