

Operator's Manual

HomeFill™ Oxygen Post Valve Cylinder

HF2POST6

HF2POST9

HF2POSTD



“Caution: Federal law restricts this device to sale or rental by or on order of a physician, or any other practitioner licensed by the law of the State in which he/she practices to use or order the use of this device.”

Dealer: This manual MUST be given to the end user.

User: Before using this cylinder, read this manual and save for future reference.

For more information regarding Invacare products, parts, and services, please visit www.invacare.com



Yes, you can.™

⚠ WARNING

DO NOT OPERATE THIS EQUIPMENT WITHOUT FIRST READING AND UNDERSTANDING THIS MANUAL. IF YOU ARE UNABLE TO UNDERSTAND THE WARNINGS, CAUTIONS, AND INSTRUCTIONS, CONTACT A HEALTHCARE PROFESSIONAL, DEALER OR A QUALIFIED TECHNICIAN BEFORE ATTEMPTING TO USE THIS EQUIPMENT - OTHERWISE INJURY OR DAMAGE MAY RESULT.

⚠ WARNING

Invacare products are specifically designed and manufactured for use in conjunction with Invacare accessories. Accessories designed by other manufacturers have not been tested by Invacare.

⚠ DANGER

DO NOT SMOKE while using this device. Keep all matches, lighted cigarettes, candles or other sources of ignition out of the room in which this product is located and away from where oxygen is being delivered. Textiles and other materials that normally would not burn are easily ignited and burn with great intensity in oxygen enriched air. Failure to observe this warning can result in severe fire, property damage and cause physical injury or death.

NOTICE

The information contained in this document is subject to change without notice.

TABLE OF CONTENTS

SPECIAL NOTES	4
RECEIVING INSPECTION	4
INTENDED USE	4
SECTION 1—GENERAL GUIDELINES	5
SECTION 2—FEATURES	8
SECTION 3—TYPICAL PRODUCT PARAMETERS	9
SECTION 4—INSPECTION AND COMPRESSOR INTERFACE	10
Cylinder Prefill Inspection	10
Filling the Cylinder	13
SECTION 5—MAINTENANCE	19
SECTION 6—CYLINDER FILL TIMES	20
Troubleshooting	20
Replacement Parts - Accessories	20
LIMITED WARRANTY	22

SPECIAL NOTES

Signal words are used in this manual and apply to hazards or unsafe practices which could result in personal injury or property damage. Refer to the following table for definitions of the signal words.

SIGNAL WORD	MEANING
DANGER	Danger indicates an imminently hazardous situation which, if not avoided, will result in death or serious injury.
WARNING	Warning indicates a potentially hazardous situation which, if not avoided, could result in death or serious injury.
CAUTION	Caution indicates a potentially hazardous situation which, if not avoided, may result in property damage.

RECEIVING INSPECTION

Remove product from package and inspect for damage. If there is any damage, DO NOT use. Contact your dealer/ Home Care equipment provider.

INTENDED USE

To store supplemental oxygen for use with a CGA 870 post valve compatible conserver or regulator to be used by patients who may have difficulty extracting oxygen from the air they breathe.

NOTE: Updated versions of this manual are available on www.inovacare.com.

SECTION I—GENERAL GUIDELINES

WARNING

SECTION I - IMPORTANT SAFEGUARDS contains important information for the safe operation and use of this product. **DO NOT** use this product or any available optional equipment without first completely reading and understanding these instructions and any additional instructional material such as **Owner's Manuals, Service Manuals or Instruction Sheets** supplied with this product or optional equipment. If you are unable to understand the **Warnings, Cautions or Instructions**, contact a health care professional, dealer or technical personnel before attempting to use this equipment - otherwise, injury or damage may occur.

DANGER

This product is not intended as a life-sustaining or life-supporting device.

WARNING

Only personnel instructed and trained in the use of the HF2POST6, HF2POST9, and HF2POSTD Cylinder Assembly should operate this product.

Product contains magnetic, ferrous material that may affect the results of an MRI.

Be sure all connections are tight and leak free.

DO NOT use a liquid leak detector to test for leaks.

DO NOT autoclave.

DO NOT gas sterilize with ethylene oxide.

DO NOT clean with aromatic hydrocarbons.

⚠ WARNING

DO NOT attempt to repair product.

DO NOT immerse product in any kind of liquid.

Store product in a clean area when not in use.

Only use an Invacare Corporation HF2POST6BAG or HF2POST9BAG carrying bag.

NEVER smoke in an area where oxygen is being administered.

ALWAYS confirm prescribed dose before administering to patient and monitor on a frequent basis.

DO NOT use if dirt or contaminants are present on or around cylinder, valve, product or connecting devices.

NEVER use near any type of flame or flammable/explosive substances, vapors or atmosphere.

ALWAYS follow ANSI and CGA standards for Medical Gas Products and Flowmeters (E-7) and Oxygen Handling (G-4).

The use of this device is limited to the oxygen patient. Cylinders MUST be used only by the oxygen patient and are not to be distributed to any other individual for any purpose.

DO NOT allow oil from your hands or other sources to come into contact with the cylinder fittings. These substances may become flammable in the presence of oxygen and cause injury. Avoid touching the cylinder fitting whenever possible.

Example of items to avoid are hand creams or lotions, cooking oils, suntan oils or sunblocks and similar oily products. If you use these types of products Invacare suggests you wash your hands prior to using this product. If the cylinder fitting should come in contact with such substances it should be cleaned off with a damp cloth prior to connecting it to the compressor.

⚠ WARNING

NEVER oil or lubricate the cylinder fittings. NEVER use any penetrating oil or lubricant such as WD-40 or 3 in One. If connection difficulty is experienced verify that the cylinder fitting is being inserted straight down into the compressor coupler. If continued difficulty is experienced contact your supplier for assistance.

DO NOT allow cylinders to tip or fall. Secure gas cylinders so they cannot fall. Ensure cylinder is always in upright position.

DO NOT store cylinders near sources of heat or flame.

DO NOT use while sleeping without consulting your healthcare provider.

DO NOT place the unit under clothing while in use. When this product is in use a small amount of oxygen is vented. Wearing the unit under clothing may saturate fabrics with oxygen and cause them to burn rapidly if exposed to sparks or flame. It may take several hours for oxygen levels in fabrics to return to normal.

SECTION 2—FEATURES

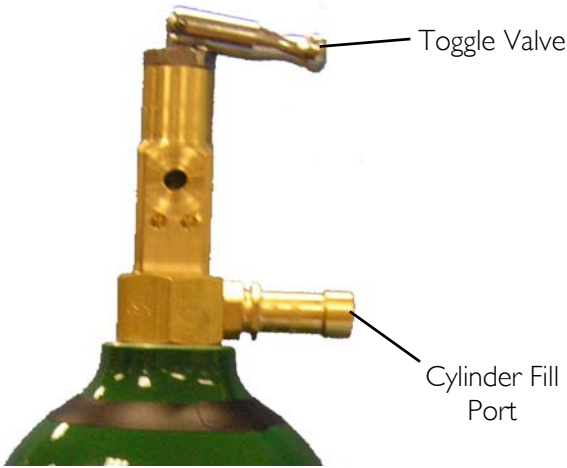

FIGURE 2.1 Product Diagram

SECTION 3—TYPICAL PRODUCT PARAMETERS

DIMENSIONS:	
HF2POST6: Weight	4.0 lbs (1.81 kg)
HF2POST6: Overall Length	11.1 in. (2.8 cm)
HF2POST6: Diameter	4.4 in. (11.1 cm)
HF2POST9: Weight	5.0 lbs (2.27 kg)
HF2POST9: Overall Length	14 in (35.5 cm)
HF2POST9: Diameter	4.4 in (11.1 cm)
HF2POSTD: Weight	6.30 lbs (2.85 kg)
HF2POSTD: Overall Length	20.8 in (52.8 cm)
HF2POSTD: Diameter	4.4 in (11.1 cm)
STORAGE CONDITIONS TEMPERATURE:	-40°F (-40°C) to 140°F (60°C)
MAXIMUM HUMIDITY:	95%

SECTION 4—INSPECTION AND COMPRESSOR INTERFACE

NOTE: Refer to the HomeFill™ Compressor Owner's Manual for compressor operating instructions.

Cylinder Prefill Inspection

WARNING

All cylinders MUST be inspected before attempting to fill; otherwise, injury or damage may occur.

NEVER smoke in an area where oxygen is being administered.

NEVER use near any type of flame or flammable/explosive substances, vapors or atmosphere.

NOTE: For this procedure, refer to FIGURE 4.1 on page 12.

The Hydrostatic Testing Date

Aluminum cylinders **MUST** undergo testing every five years.

WARNING

DO NOT fill cylinders that have not been tested in the past five years. Otherwise, serious personal injury may result. Contact your dealer for replacement.

External Examination

NOTE: For this procedure, refer to FIGURE 4.1 on page 12.

1. Examine the outside of the cylinder for the following conditions and replace the cylinder if they exist:
 - Dents or dings
 - Arc burns
 - Oil or grease
 - Any other signs of damage that might cause a cylinder to be unacceptable or unsafe for use.
2. Examine the cylinder for evidence of fire or thermal damage. Evidence includes charring or blistering of the paint, or other protective coating or heat sensitive indicator. If fire or thermal damage is found, replace the cylinder.
3. Inspect the cylinder fillport for the following and replace if found:
 - Debris, oil or grease
 - Noticeable signs of damage
 - Signs of corrosion inside the valve
 - Signs of excessive heat or fire damage

⚠ DANGER

Improper filling or abuse of this cylinder, or failure to follow these safety instructions may cause serious bodily injury or death. High pressure oxidizing gas vigorously accelerates combustion.

DO NOT alter or modify cylinder or related components. DO NOT use Oil or Grease. Keep cylinder, cylinder valve, all equipment and connections free of oil and grease to avoid violent ignition resulting in serious bodily injury or death.

⚠ WARNING

For medical applications. Use only as directed by a licensed practitioner. Uninterrupted use of high concentrations of oxygen over a long duration, without monitoring its effect on oxygen content of arterial blood, may be harmful.

Oxygen Cylinders filled by the Venture HomeFill shall be used for personal use only. "Not to be filled for resale or use by professional users".

This cylinder is to be used with the Invacare Venture HomeFill system. This cylinder contains 93 ± 3% oxygen produced by an oxygen concentrator using the pressure swing adsorption process.

DO NOT handle cylinder or use contents until you are professionally trained, including emergency procedures.

Use in accordance with Venture HomeFill Operator's Manual. Open valve slowly. Close valve after each use and when empty. Secure cylinder during storage and use. No smoking in cylinder area. Keep away from heat, flame and spark. Keep out of reach of children. DO NOT drop.

Transfilling of this gas is performed by Venture HomeFill Only.

Cylinders that have been refinished and/or exposed to elevated temperatures must be hydrostatically tested before filling. Cylinder temperature should not exceed 125°F (52°C). Aluminum cylinders subject to the action of fire or heated to temperatures in excess of 350°F must be withdrawn from service and condemned by trained personnel. DO NOT use caustic paint strippers. Valve and safety relief devices must be removed and replaced by trained and authorized personnel. DO NOT alter or change valve assembly.

Invacare Corporation
2101 E. Lake Mary Blvd.
Sanford, FL 32773
1-800-832-4707

DO NOT REMOVE THIS PRODUCT LABEL
Not for Commercial Resale

Part Number 1125090 Rev B - 11/04



FIGURE 4.1 External Examination

Checking Cylinder Pressure

⚠ WARNING

NEVER use tools of any kind to connect/disconnect the cylinder and the compressor. Otherwise, severe injury and/or damage may occur.

DO NOT drop oxygen cylinders. Use two hands when handling/transporting oxygen cylinders. Otherwise, injury or damage may occur.

DO NOT use a liquid leak detector to test for leaks.

NOTE: For this procedure, refer to FIGURE 4.2 on page 14.

1. Install a conserver or regulator onto the cylinder according to the device manufacturer instructions.

2. Ensure toggle valve is open. Open the toggle valve by rotating counterclockwise.
3. Examine the gauge on the connected conserver or regulator. Perform one of the following:
 - If the cylinder pressure is **less** than 1500 psig, fill the cylinder. Connect the cylinder to the compressor. Refer to Filling the Cylinder on page 13.
 - If the cylinder pressure is **greater** than 1500 psig., DO NOT attempt to fill this cylinder. It may not fill. Use cylinder as normal.

Filling the Cylinder

NOTE: For this procedure, refer to FIGURE 4.2 thru FIGURE 4.7.

1. Check the cylinder pressure before attempting to fill cylinder. Refer to Checking Cylinder Pressure on page 12.
2. Close the toggle valve by rotating clockwise (FIGURE 4.2).
3. Remove the conserver or regulator according to the device manufacturer instructions (FIGURE 4.2).

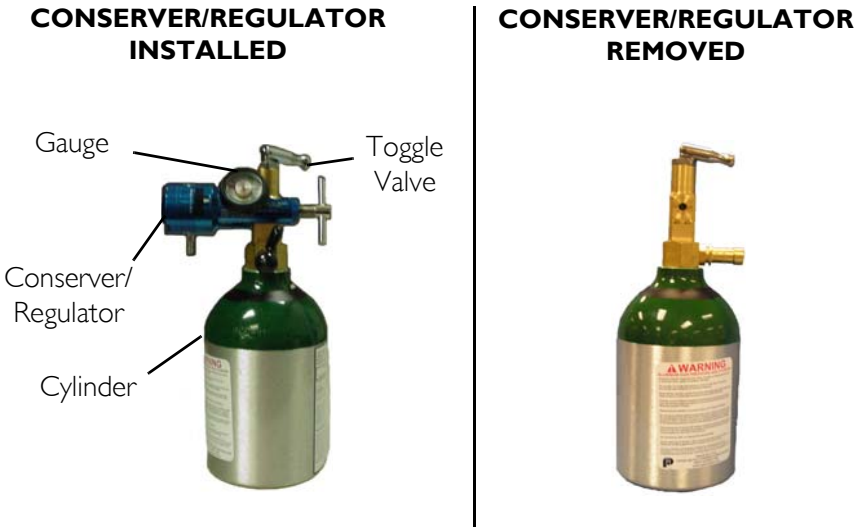

FIGURE 4.2 Component Identification

4. Remove the post valve cover (located on the cylinder) and the connector fillport covers (located on the compressor) (FIGURE 4.3).

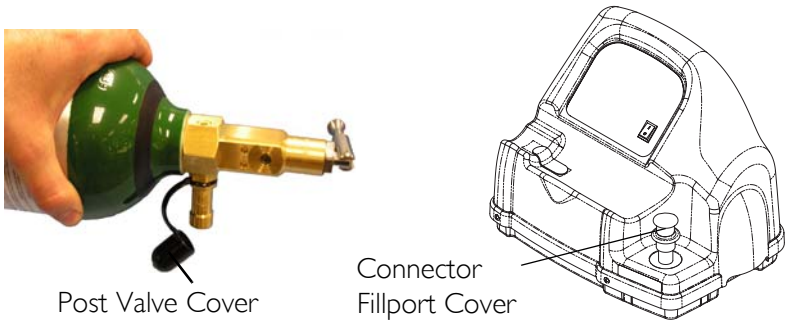

FIGURE 4.3 Fillport Covers

5. On the compressor unit, momentarily push **DOWN** on the outer ring (sleeve) of the connector fillport to reset the connector (FIGURE 4.4).

NOTE: If the outer ring (sleeve) is in the UP position (GREEN dots not visible), the connector fillport will not be able to accept the cylinder fillport. Pushing DOWN momentarily will reset the connector fillport (GREEN dots visible) to accept the cylinder fillport.

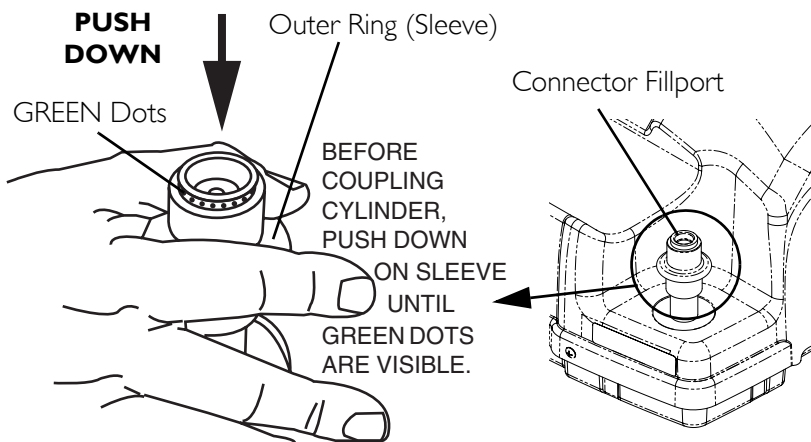

FIGURE 4.4 Resetting Connector Fillport

6. Grasp the cylinder assembly as shown in Detail "A" in FIGURE 4.5.
7. Position the cylinder in the compressor cradle as shown in Detail "C" in FIGURE 4.5.
8. Align the cylinder fillport with the connector fillport as shown in Detail "C" in FIGURE 4.5.
9. Pull UP on the outer ring (sleeve) of the connector fillport (Detail "B") while pushing DOWN on the cylinder assembly to couple the cylinder fillport into the connector fillport as shown in Detail "B" in FIGURE 4.5.

NOTE: The cylinder is properly connected when an audible "click" is heard.

10. Press the compressor power switch to the On (I) position.

SECTION 4—INSPECTION AND COMPRESSOR INTERFACE

NOTE: Refer to Cylinder Fill Times on page 20 for the length of time it will take to fill the cylinder.

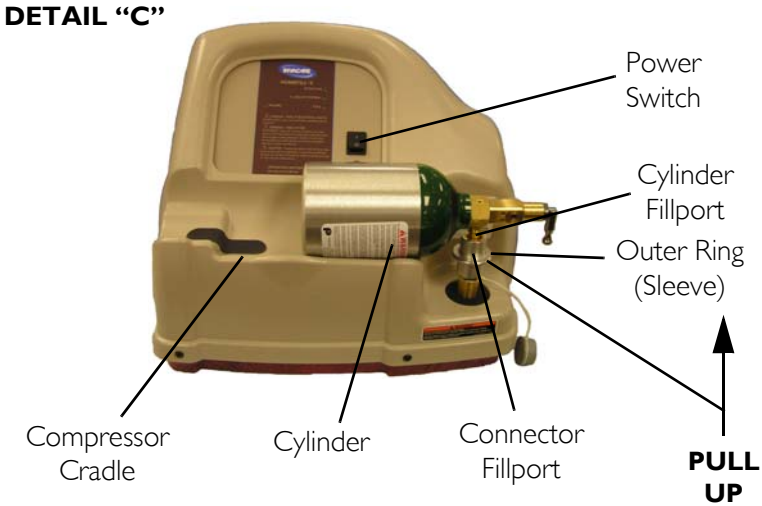
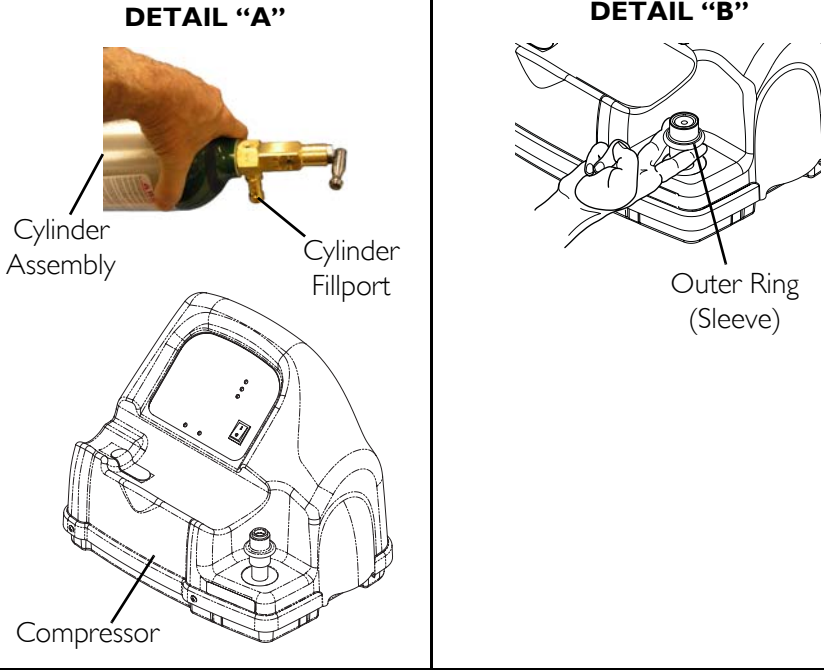

FIGURE 4.5 Connecting the Cylinder to the Compressor

11. After the cylinder is full, press the compressor power switch to the Off (O) position (FIGURE 4.6).
12. Grasp the cylinder assembly (FIGURE 4.6).
13. With the other hand, grasp the outer ring (sleeve) of the connector fillport and push DOWN (FIGURE 4.6).
14. Lift up on the cylinder assembly to remove from the connector fillport (FIGURE 4.6).

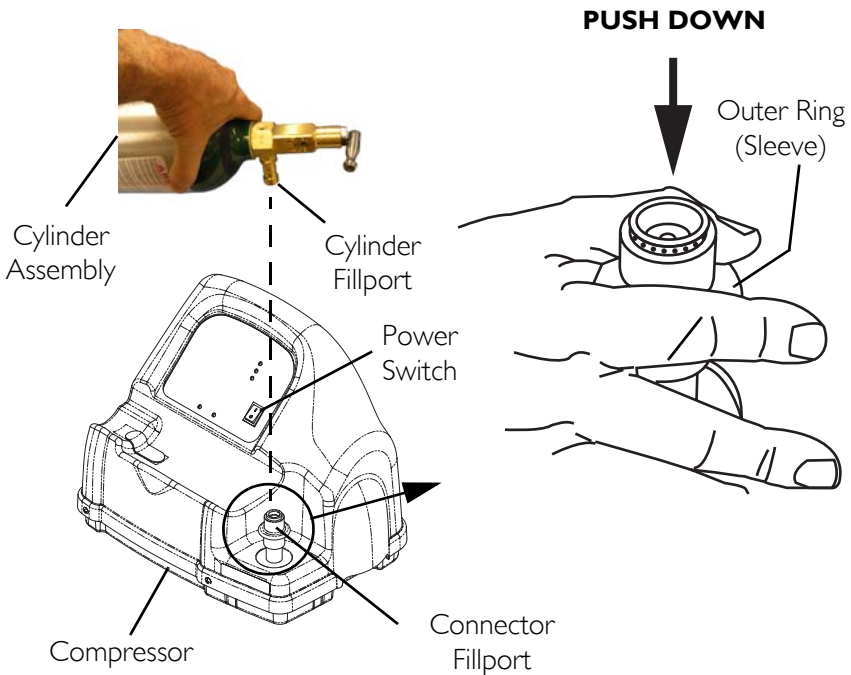

FIGURE 4.6 Disconnecting the Cylinder from the Compressor

15. When the cylinder fillport is disconnected from the connector fillport, release the outer ring (sleeve) of the connector fillport (FIGURE 4.6).
16. Remove the cylinder from the compressor cradle (FIGURE 4.6).

⚠ WARNING

The fillport cover on the connector fillport and the post valve fillport **MUST** be replaced after filling and whenever not in use. If either of the fillport covers are missing contact your healthcare provider before using.

17. Place the fillport covers onto the connector fillport (located on the compressor) and post valve fillport (located on the cylinder) (FIGURE 4.7).
18. Install a CGA870 post valve compatible conservor or regulator according to the manufacturer’s instructions.
19. Open the toggle valve by turning counterclockwise and examine the conservor or regulator gauge to ensure cylinder is full (needle pointing into GREEN area). If the cylinder is not full, perform the following:
 - Repeat Filling the Cylinder on page 13.
 - If cylinder is not full after second attempt to fill, contact the provider.

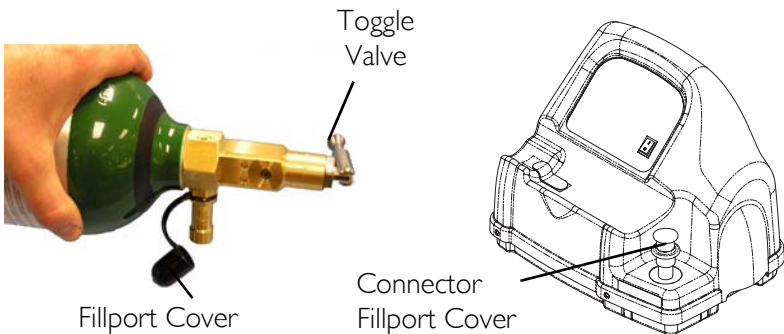

FIGURE 4.7 Connector Fillport

SECTION 5—MAINTENANCE

1. After each use, clean exterior of the product with a dry, lint free cloth only.
2. Store product in a clean area free from grease, oil, and other sources of contamination.

CAUTION

DO NOT use cleaning solutions.

DO NOT immerse product in any kind of liquid.

All repairs MUST be done by Invacare Corporation.

SECTION 6—CYLINDER FILL TIMES

NOTE: All filling times are approximate and may vary on environmental conditions.

Cylinder Filling Times	Concentrator Flow Rate to Patient: (Platinum 5 up to 3 L/min. and Platinum 10 up to 5 L/min)		
	HF2POST6	HF2POST9	HF2POSTD
NORMAL	1 hr 25 min	2 hr 20 min	3 hr 20 min
MAXIMUM	1 hr 50 min	2 hr 45 min	3 hr 50 min

Troubleshooting

If post valve cylinder fails to function, try the following solutions. If problem cannot be corrected, consult your dealer/home care equipment provider.

PROBLEM	POSSIBLE CAUSE	SOLUTION
No flow.	<ol style="list-style-type: none"> 1. Regulator or conserver is in “Off” position. 2. Cylinder empty. 3. Toggle Valve closed. 4. Conserver not sensing breath. 	<ol style="list-style-type: none"> 1. Set to prescribed setting. 2. Replace/fill cylinder. 3. Open toggle valve. 4a. Check position of cannula in nose. Do not breathe through mouth. 4b. Check to see if the cannula is kinked.

Replacement Parts - Accessories

HF2POST6BAG or HF2POST9BAG Carrying Bag.

NOTES

LIMITED WARRANTY

PLEASE NOTE: THE WARRANTY BELOW HAS BEEN DRAFTED TO COMPLY WITH FEDERAL LAW APPLICABLE TO PRODUCTS MANUFACTURED AFTER JULY 4, 1975.

This warranty is extended only to the original purchaser/user of our products.

This warranty gives you specific legal rights and you may also have other legal rights which vary from state to state.

Invacare warrants this product to be free from defects in materials and workmanship for a period of three years from date of purchase. If within such warranty period any such product shall be proven to Invacare's satisfaction to be defective, such product shall be repaired or replaced, at Invacare's option. This warranty does not apply to problems arising from normal wear and tear or failure to adhere to these instructions, nor does it include shipping charges incurred in replacement part installation or repair of any such product. Invacare's sole obligation and your exclusive remedy under this warranty shall be limited to such repair and/or replacement.

For warranty service, please contact the Invacare service department during normal business hours at the toll-free telephone number identified on the back cover of this manual.

Upon receiving notice of an alleged defect in a product, Invacare will issue a serialized return authorization. It shall be the responsibility of the purchaser to pack the product(s) or part(s) in an appropriate manner to avoid shipping damage and return the product(s) or part(s), at the purchaser's expense, to either Invacare's plant or service center as specified by Invacare in advance. The defective product(s) or component part(s) must be returned for warranty inspection using the serial number as identification within 30 days of the return authorization date. **DO NOT** return any product(s) or part(s) to our factory or service center without prior consent. **C.O.D.** shipments will be refused - please pre-pay shipping charges.

LIMITATIONS AND EXCLUSIONS: THE FOREGOING WARRANTY SHALL NOT APPLY TO SERIAL NUMBERED PRODUCTS IF THE SERIAL NUMBER HAS BEEN REMOVED OR DEFACED; PRODUCTS SUBJECTED TO NEGLIGENCE, ACCIDENT, IMPROPER OPERATION, MAINTENANCE, OR STORAGE; PRODUCTS MODIFIED WITHOUT INVACARE'S EXPRESS WRITTEN CONSENT (INCLUDING, BUT NOT LIMITED TO, MODIFICATION THROUGH THE USE OF UNAUTHORIZED PARTS OR ATTACHMENTS); PRODUCTS DAMAGED BY REASON OF REPAIRS MADE TO ANY COMPONENT WITHOUT THE SPECIFIC CONSENT OF INVACARE; PRODUCTS DAMAGED BY CIRCUMSTANCES BEYOND INVACARE'S CONTROL; OR PRODUCTS REPAIRED BY ANYONE OTHER THAN INVACARE OR AN INVACARE SERVICE CENTER. SUCH EVALUATION SHALL BE SOLELY DETERMINED BY INVACARE.

THE FOREGOING EXPRESS WARRANTY IS EXCLUSIVE AND IN LIEU OF ANY OTHER WARRANTIES WHATSOEVER, WHETHER EXPRESSED OR IMPLIED, INCLUDING THE IMPLIED WARRANTIES OF MERCHANTABILITY AND FITNESS FOR A PARTICULAR PURPOSE, AND THE SOLE REMEDY FOR VIOLATIONS OF ANY WARRANTY WHATSOEVER, SHALL BE LIMITED TO REPAIR OR REPLACEMENT OF THE DEFECTIVE PRODUCT PURSUANT TO THE TERMS CONTAINED HEREIN. THE APPLICATION OF ANY IMPLIED WARRANTY WHATSOEVER SHALL NOT EXTEND BEYOND THE DURATION OF THE EXPRESS WARRANTY PROVIDED HEREIN. INVACARE SHALL NOT BE LIABLE FOR ANY CONSEQUENTIAL OR INCIDENTAL DAMAGES WHATSOEVER.

SOME STATES DO NOT ALLOW THE EXCLUSION OR LIMITATION OF INCIDENTAL OR CONSEQUENTIAL DAMAGE, OR LIMITATION OF HOW LONG AN IMPLIED WARRANTY LASTS, SO THE ABOVE EXCLUSION AND LIMITATION MAY NOT BE APPLICABLE.

THIS WARRANTY SHALL BE EXTENDED TO COMPLY WITH STATE/PROVINCIAL LAWS AND REQUIREMENTS.



Yes, you can:

Invacare Corporation

USA

One Invacare Way

Elyria, Ohio USA

44036-2125

800-333-6900

Technical Services

800-832-4707

www.invacare.com

All rights reserved. Trademarks are identified by the symbols [™] and [®]. All trademarks are owned by or licensed to Invacare Corporation unless otherwise noted.

© 2007 Invacare Corporation

Part No 1148114 Rev B - 9/07