



Table of Contents

Introduction.....	Page 4-5
CE Declaration.....	Page 6-7
Safety Instructions.....	Page 8-9
Explanation of Symbols.....	Page 10
Achiever Operating Controls.....	Page 11-12
Ultimate II Operating Controls.....	Page 13-14
Ultimate IISE Operating Controls.....	Page 15-17
Innovator Operating Controls.....	Page 18-19
Receiver RC-07 Operating Controls.....	Page 20-21
Student Microphone Operating Controls.....	Page 22
Teacher Microphone Operating Controls.....	Page 23
Charging the Battery in the microphones	Page 24
SoloSolution Operating Controls.....	Page 25
EDS-07 IR Dome Sensor Operating Controls.....	Page 26
AE-DCF Dome Sensor Coupler.....	Page 27
Operating Procedure.....	Page 28
Remote Volume Control.....	Page 29
Using the microphones as a transmitter.....	Page 30
Setting the Aux Mute.....	Page 31
Wiring Connections and Installation.....	Page 32-42
EDS-07 Dome Sensor Wiring and Placement.....	Page 43-44
Setting the PA Aux Mute.....	Page 45-46
Setting the EMG Aux Mute.....	Page 47
Fuse Part Numbers	Page 48
Precautions for Installation.....	Page 49-52
Installing the Bracket.....	Page 53
Fuse Part Numbers.....	Page 54
Teachers Check list.....	Page 55
Troubleshooting.....	Page 56-57

Table of Contents

Repair Form	Page 58
Power Cords for EU.....	Page 59-60
Safety Instructions for EU.....	Page 61
WEEE Fitting.....	Page 62
Warranty.....	Page 63

Introduction

AUDIO ENHANCEMENT has been creating technologically advanced products that exceed expectations for over 25 years. They are designed by caring professionals for those who teach and those who will become the future leaders of America. Selecting the infrared classroom sound amplification system is the most important step to improve the learning environment.

Your infrared classroom system represents a breakthrough in classroom amplification. It assures you the clarity and interference free performance you expect; trouble free performance with unlimited numbers of systems used in the same building.

Please read through this manual before installing and using the IR systems and refer to it often to become familiar with classroom sound amplification systems. Our staff is available to answer any questions that may arise; call 1-800-383-9362.

Introduction



When asked to rank the importance of nine different types of equipment used in classroom instruction, **34% of the teachers** in general education ranked **classroom amplification most important**, even over the overhead projector, which came in second at 18% and the computer at 16%! (1)

45% of the school day is spent by **children engaged in listening activities**. (2)

90% of a very young child's knowledge is attributed to incidental reception of a conversation around them. (3)

1. **Allen, L. (1993)**. Promoting the usefulness of classroom amplification equipment. *Educational Audiology Monograph* 3, 32-34.
2. **Berg, F.S. (1987)**. *Facilitating classroom listening: A handbook for teachers of normal and hard of hearing students*. Boston: College-Hill Press/Little, Brown.
3. **Flexer, Carol (1993)**. "Classroom Management of Children with Hearing Loss: Preferential Seating is NOT enough" presentation. San Francisco, CA 8/14/93.

CE Declaration

English

We declare under our sole responsibility that the product to which this declaration relates is in conformity with the standards or other normative documents following the provisions of Directives 2006/95/EC and 2004/108/EC.

German

Wir erklären in alleiniger Verantwortung, daß das Produkt, auf das sich diese Erklärung bezieht, mit der folgenden Normen oder normativen Dokumenten übereinstimmt. Gemäß den Bestimmungen der Richtlinie 2006/95/EC und 2004/108/EC.

French

Nous déclarons sous notre seule responsabilité que le produit auquel se réfère la présente déclaration est conforme aux normes ou autres documents normatifs conformément aux dispositions des directives 2006/95/EC and 2004/108/EC.

Spanish

Nosotros declaramos bajo nuestra única responsabilidad que el producto a que hace referencia esta declaración está conforme con las normas u otros documentos normativos siguiendo las estipulaciones de las directivas 2006/95/CE y 2004/108/CE.

Italian

Noi dichiariamo sotto nostra esclusiva responsabilità che il prodotto a cui si riferisce la presente dichiarazione risulta conforme ai seguenti standard o altri documenti normativi conformi alle disposizioni delle direttive 2006/95/CE e 2004/108/CE.

Dutch

Wij verklaren als enige aansprakelijke, dat het product waarop deze verklaring betrekking heeft, voldoet aan de volgende normen of andere normatieve documenten, overeenkomstig de bepalingen van Richtlijnen 2006/95/EC en 2004/108/EC.

Danish

Vi erklærer os eneansvarlige for, at dette produkt, som denne deklARATION omhandler, er i overensstemmelse med standarder eller andre normative dokumenter i følge bestemmelserne i direktivene 2006/95/EC og 2004/108/EC.

CE Declaration

Swedish

Vi deklarerar härmed vårt fulla ansvar för att den produkt till vilken denna deklARATION hänvisar är i överensstämmelse med standarddokument, eller andra normativa dokument som framställs i direktiv nr. 2006/95/EC och 2004/108/EC.

Finnish

Ilmoitamme yksinomaisella vastuullamme, että tuote, jota tämä ilmoitus koskee, noudattaa seuraavia standardeja tai muita ohjeellisia asiakirjoja, jotka noudattavat direktiivien 2006/95/EC ja 2004/108/EC säädöksiä.

Norwegian

Vi erklærer oss alene ansvarlige for at produktet som denne erklæringen gjelder for, er i overensstemmelse med følgende normer eller andre normgivende dokumenter som følger bestemmelsene i direktivene 2006/95/EC og 2004/108/EC.

Safety Instructions

- 1) Read these instructions.
- 2) Keep these instructions.
- 3) Heed all warnings.
- 4) Follow all instructions.
- 5) Do not use this apparatus near water.
- 6) Clean only with dry cloth.
- 7) Do not block any ventilation openings. Install in accordance with the manufacturer's instructions.
- 8) Do not use near any heat sources such as radiators, heat registers, stoves, or other apparatus (including amplifiers) that produce heat.
- 9) Do not defeat the safety purpose of the polarized or grounding-type plug. A polarized plug has two blades with one wider than the other. A grounding-type plug has two blades and a third grounding prong. The wide blade or the third prong are provided for your safety. If the provided plug does not fit into your outlet, consult an electrician for replacement of the obsolete outlet.
- 10) Protect the power cord from being walked on or pinched particularly at plugs, convenience receptacles and the points where they exit from the apparatus.
- 11) Only use attachments/accessories specified by the manufacturer.
- 12) Use only with the cart, stand, tripod, bracket, or table specified by the manufacturer, or sold with the apparatus. When a cart is used, use caution when moving the cart/apparatus combination to avoid injury from tip-overs.



- 13) Unplug this apparatus during lightning storms or when unused for long periods of time.
- 14) Refer all servicing to qualified service personnel. Servicing is required when the apparatus has been damaged in any way, such as power-supply cord or plug is damaged, liquid has been spilled or objects fallen into the apparatus, the apparatus has been exposed to rain or moisture, does not operate normally, or has been dropped.

WARNING:

- **To reduce the risk of fire or electric shock, do not expose this receiver/amplifier to rain or moisture.**
- **The apparatus should not be exposed to dripping or splashing water. Objects filled with liquids should not be placed on or next to the apparatus.**

Safety Instructions

WARNING:

- This apparatus must be earthed.
- Apparatus shall be connected to a main socket outlet with a protective earthing connection.
- The mains plug or an appliance coupler shall remain readily operable.
- To prevent fire or electric shock hazard, do not expose this apparatus to rain or moisture.
- The apparatus should not be exposed to dripping or splashing and that no objects filled with liquids, such as vases, should be placed on the apparatus.
- All work related to the installation of this product should be made by qualified service personnel or system installers.
- For PERMANENTLY CONNECTED APPARATUS provided neither with an all-pole MAINS SWITCH nor an all-pole circuit breaker, the installation should be carried out in accordance with all applicable installation rules.
- The connections should comply with local electrical code.
- When the equipment is not used, make sure to contact your dealer and remove it.

CAUTION:

Before attempting to connect or operate this product, please read the label on the bottom (CAE-20W).

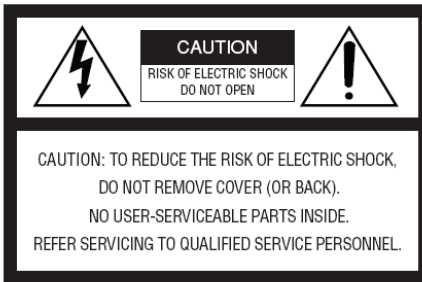

The lightning flash with arrowhead symbol, within an equilateral triangle, is intended to alert the user to the presence of uninsulated "dangerous voltage" within the product's enclosure that may be of sufficient magnitude to constitute a risk of electric shock to persons.



The exclamation point within an equilateral triangle is intended to alert the user to the presence of important operating and maintenance (servicing) instructions in the literature accompanying the appliance.

Explanation of Symbols

 220 - 240 Vac.

A.C. Power Only

50 to 60 Hz

Rated Mains Frequency

The date or a dating code not exceeding any three consecutive months of manufacture. The dating code shall be in an established alphanumeric code affirmed by the manufacturer. The coding system shall have a minimum 10 year repetition cycle.

Operating Controls

ACHIEVER

Front View

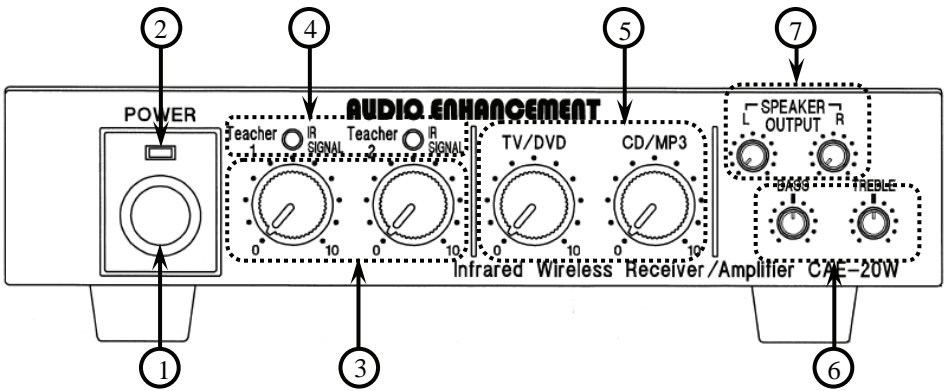

- (1) Power switch. Turns the power on/off.
- (2) Power indicator. Lights "green" when the power is turned ON.
- (3) Infrared Microphone Volume Control [Teacher 1 and 2]. This control is used to adjust the level of the infrared microphones.
- (4) Infrared Signal Indicator [Teacher 1 and 2] . Lights "green" when the infrared wireless receiver is receiving a signal.
- (5) Auxiliary Input volume [TV/DVD and CD/MP3] .This Control adjusts the volume of the auxiliary inputs connected to the input terminals (11).
- (6) Equalizer [BASS, TREBLE] . The Bass and Treble controls allow the teacher to have control over the quality of his or her voice. This adjustment is made by adjusting the "BASS" low-range or "TREBLE" high-range until the desired sound quality is achieved.
- (7) Speaker output volume [SPEAKER L, R].Output levels from each pair of speakers are adjustable with this volume

● AC adapter. Use the "3A-621DA24" AC adapter provided to supply power to the "Achiever".

Operating Controls

ACHIEVER

Rear View

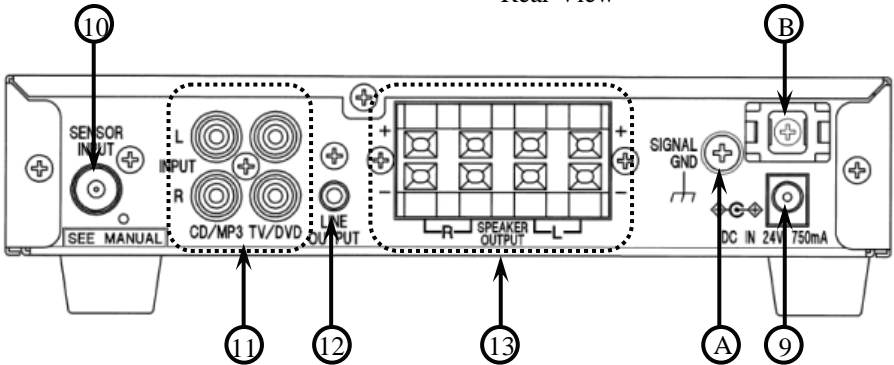

(9) DC power terminal. The AC adapter provided supplies 24 V DC power.

(10) Sensor input terminal. Connection via F-connector and coaxial cable for the infrared sensors. It also supplies power to the sensors (24 V).

(11) Input terminal [TV/DVD, CD/MP3] . Connections for TV/DVD, and CD/MP3.

(12) Line output terminal. Provides a line level output for connection of personal FM system, recording devices, or video conferencing systems. All input signals, including microphones and auxiliary inputs are mixed and provided at the line output terminal.

(13) Speaker output terminals. Connections for the speakers (8 Ohms).

(A) Ground screw [SIGNAL GND]

(B) Mount for cable clamp - Used to bundle cables and speaker wires with tie-wraps.

■ IDENTIFICATION

The vendor's name, the model number and the nature of supply are marked on bottom of the apparatus.

Operating Controls

ULTIMATE II

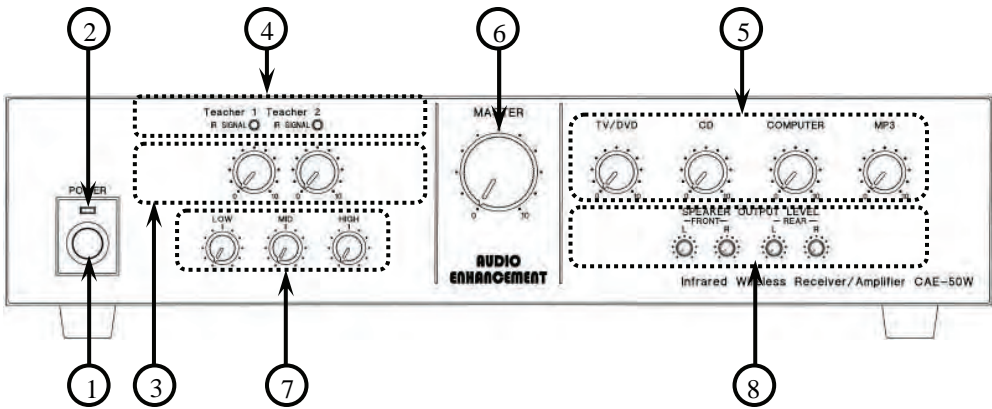

- (1) Power switch. Turns the power on/off.
- (2) Power indicator. Lights "green" when the power is turned ON.
- (3) Infrared Microphone Volume Control [Teacher 1 and 2]. This control is used to adjust the level of the infrared microphones.
- (4) Infrared Signal Indicator [Teacher 1 and 2]. Lights "green" when the infrared wireless receiver is receiving a signal.
- (5) Auxiliary Input volume [TV/DVD, CD, COMPUTER, and MP3]. This Control adjusts the volume of the auxiliary inputs connected to the input terminals (11).
- (6) Master volume. Adjusts overall level of the system.
- (7) Equalizer [LOW, MID, HIGH]. The 3-Band Equalizer allows the teacher to have control over the quality of his or her voice. This adjustment is made by adjusting "LOW", "MID", or "HIGH" controls until the desired sound quality is achieved.
- (8) Speaker output volume [FRONT L/R, REAR L/R]

The level from each speaker can be independently adjusted with these controls.

- AC adapter. Use the "3A-901DA24-048" AC adapter provided to supply power to the "Ultimate II".

Operating Controls

ULTIMATE II

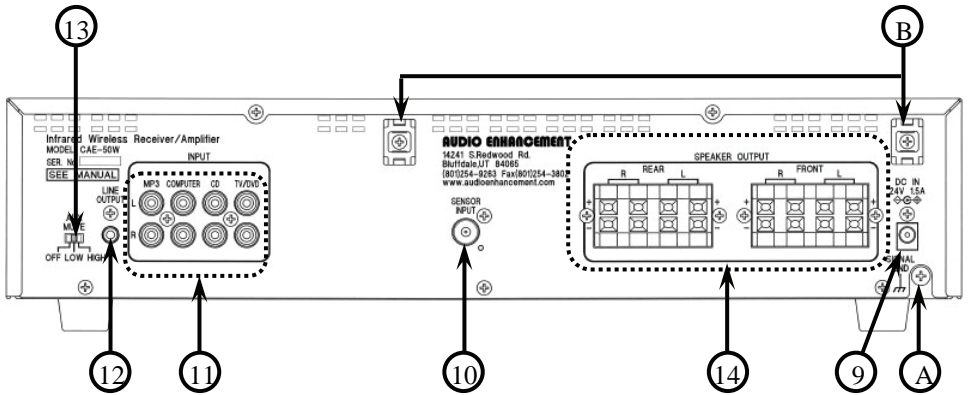

(9) DC power terminal. The AC adapter provided supplies 24 V DC power.

(10) Sensor input terminal. Connection via F-connector and coaxial cable for the infrared sensors. It also supplies power to the sensors (24 V).

(11) Input terminal [TV/DVD, CD, COMPUTER, MP3].Connections for TV/DVD, CD, COMPUTER, and MP3.

(12) Line output terminal. Provides a line level output for connection of personal FM system, recording devices, or video conferencing systems. All input signals, including microphones an auxiliary inputs are mixed and provided at the line output terminal.

(13) AUX mute setting switch [OFF/LOW/HIGH] The Aux mute switch allows selection of whether or not the teachers voice mutes the auxiliary inputs when he or she speaks. The 'off' setting provides for no muting. The Low setting provides for a standard level of attenuation. The High setting provides for a faster attenuation. Set the switch to 'low' for normal operation

(14) Speaker output terminal. Connections for the speakers (8 Ohms).

(A) Ground screw [SIGNAL GND]

(B) Mount for cable clamp - Used to bundle cables and speaker wires with tie-wraps.

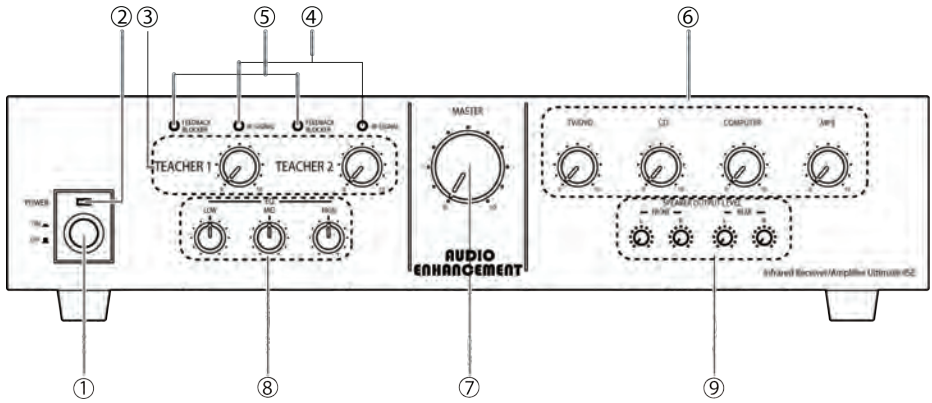

- (1) Power switch. Turns the power on/off.
- (2) Power indicator. Lights "green" when the power is turned ON.
- (3) Infrared Microphone Volume Control [Teacher 1 and 2]. This control is used to adjust the level of the infrared microphones.
- (4) Infrared Signal Indicator [Teacher 1 and 2]. Lights "green" when the infrared wireless receiver is receiving a signal.
- (5) Feedback blocker indicator (orange) [Teacher 1 and 2], lights orange when the feedback blocker is activated.
- (6) Auxiliary Input volume [TV/DVD, CD, COMPUTER, and MP3]. This Control adjusts the volume of the auxiliary inputs connected to the input terminals.
- (7) Master volume. Adjusts all input volumes (3, 6) together.
- (8) Equalizer [LOW, MID, HIGH]. The 3-Band Equalizer allows the teacher to have control over the quality of his or her voice. This adjustment is made by adjusting "LOW", "MID", or "HIGH" controls until the desired sound quality is achieved.
- (9) Speaker output volume [FRONT L/R, REAR L/R]
The level from each speaker can be independently adjusted with these controls.

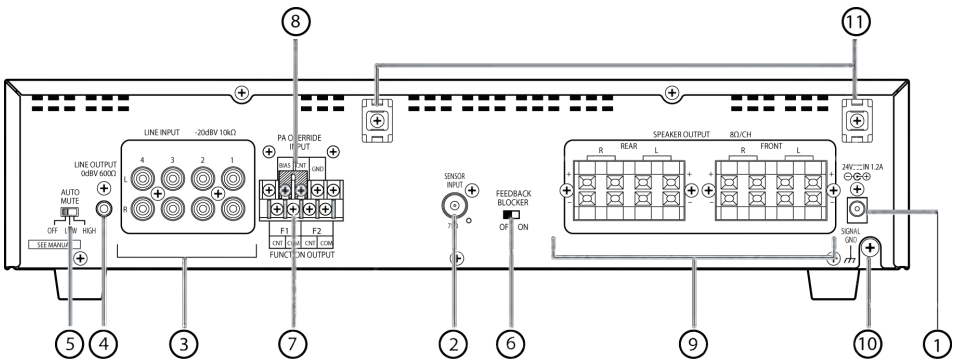

- (1) DC power supply terminal [24 V IN, 1.2 A] Connect the specified AC adaptor (accessory), and it supplies 24 V DC power.
- (2) Sensor input terminal [SENSOR INPUT 75Ω]
- (3) Line input terminals - [LINE INPUT 1,2,3,4 –20dBV 10k Ohm] Connect external audio device (such as DVD etc).
- (4) Line Output terminals [LINE OUTPUT 0dBV 600 Ohm]. Connect to recording or external audio device. Output jack is 3.5mm Tip/Sleeve (monaural).
- (5) Auto mute switch [AUTO MUTE OFF/LOW/HIGH] When activated, the microphone can interrupt the external audio device by reducing its volume. Detection sensitivity is controlled by the “LOW” and “HIGH” setting.
- (6) Feedback blocker switch [FEEDBACK BLOCKER OFF/ON] Turn this switch OFF to disable feedback blocker. Default is OFF.
- (7) Function terminals [PA OVERRIDE INPUT, BIAS/CNT/GND] See “Function” Page.
- (8) Jumper pin—Used to set up Enable/Disable of the PA override function. Default setting is Disable
- (9) Speaker Output terminals - Use speakers with impedance of 8 Ohms. Two speakers can be connected each of the four amplifiers.
- (10) Ground screw [SIGNAL GND] - When the amplifier is used with a combination of external devices, connect the earth terminal of each device to reduce the difference in potentials between devices.
- (11) Mount for cable clamp.

“F” Function

Setting the Function Channel on the Teacher microphone

1. Remove the battery cover of the microphone. Pull the battery cover in the arrow direction while pressing the “A” portion with both right and left thumbs to remove the cover.

2. Set the transmitting channel and assign function F1 or F2 with the Channel select control. To set the transmitting channels and assign functions to the function button, use the small channel setting screwdriver (microphone's accessory) to turn the channel select switch until it clicks in place.

3. F2 is the Security Alert function. Typically this is the function selected on the Teachers microphone. Channel 1 is normally used for the Teachers microphone as well. Set the switch to CH 1 in the F2 (white background) area of the switch.

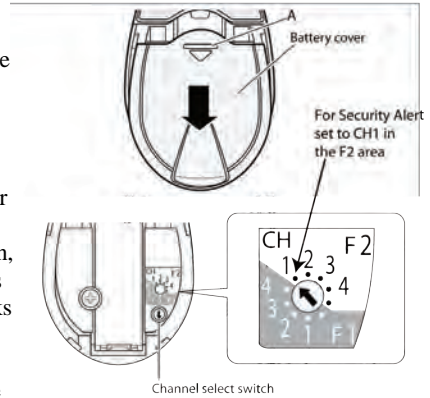

F1 is the momentary activation function. Set the Channel selector switch to the desired channel in the black background area of the label.

Amplifier Function Output Connections

Function Outputs are opto-isolated and are the equivalent of an “Open Collector” NPN transistor that can handle a maximum of 30Vdc at 20mA. The “CNT” terminal is the collector and the “COM” is the emitter.

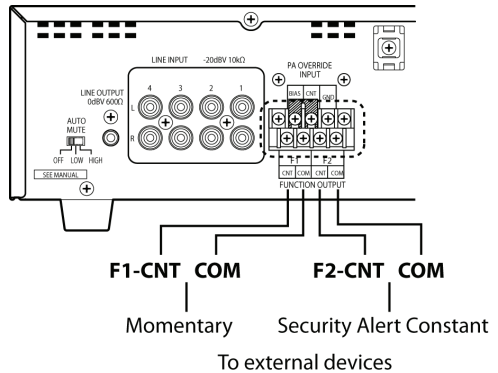

Function Action Description

F1 Function - The F1 function activation provides for a momentary (300 ms) activation of the F1 “CNT and ”COM” terminals every time the “F” button is pressed. If the “F” button is pressed and held in F1 function, it will provide a 300ms activation every 600ms. A 300ms ON followed by a 300ms OFF, repeating until the “F” button is released.

F2 Function - The F2 function activation will cause the “F2” “CNT and ”COM” terminals to activate and remain activated until the receiver is powered OFF or the receiver does not receive an “F2” signal from the microphone for 3 minutes.

The F2 transmission from a microphone can only be terminated by turning the microphone power OFF.

Operating Controls

INNOVATOR

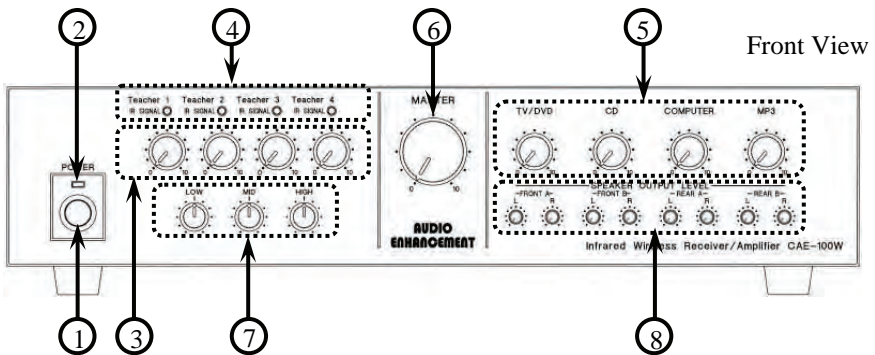

- (1) Power switch
Turns the power on/off.
- (2) Power indicator
Lights "green" when the power is turned ON.
- (3) Infrared Microphone Volume Control [Teacher 1 to 4]
This control is used to adjust the level of the infrared microphones.
- (4) Infrared Signal Indicator [Teacher 1 to 4]
Lights "green" when the infrared wireless receiver is receiving a signal.
- (5) Auxiliary Input volume [TV/DVD, CD, COMPUTER, and MP3]
This Control adjusts the volume of the auxiliary inputs connected to the input terminals (11).
- (6) Master volume
Adjusts overall level of the system.
- (7) Equalizer [LOW, MID, HIGH]
The 3-Band Equalizer allows the teacher to have control over the quality of his or her voice. This adjustment is made by adjusting "LOW", "MID", or "HIGH" controls until the desired sound quality is achieved.
- (8) Speaker output volume [FRONT A L/R, FRONT B L/R, REAR A L/R, REAR B L/R]
The level from each speaker can be independently adjusted with these controls.

● AC adapter
Use the "PW-150A2-1Y-240E" AC adapter provided to supply power to the "Innovator amplifier".

Operating Controls

INNOVATOR

Rear View

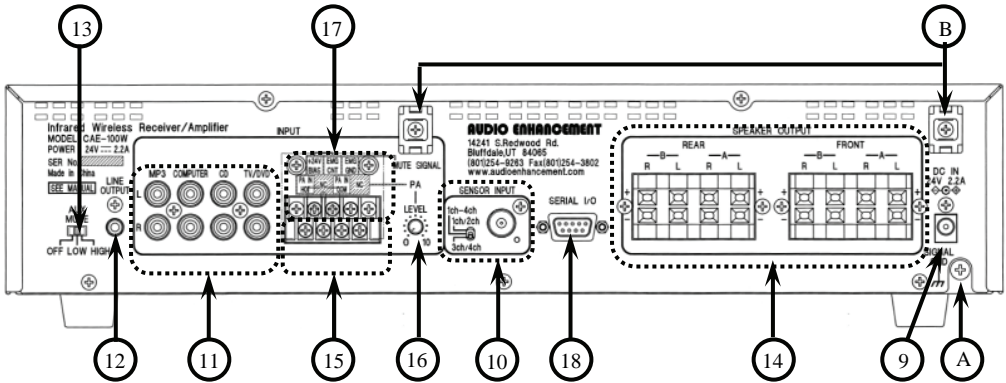

9) DC power terminal

The AC adapter provided supplies 24 V DC power.

(10) Sensor input terminal

Connection via F-connector and coaxial cable for the infrared wireless sensors. It also supplies power to the sensors (24 V).

(11) Input terminal [TV/DVD, CD, COMPUTER, MP3]

Connections for TV/DVD, CD, COMPUTER, and MP3.

(12) Line output terminal

Provides a line level output for connection of personal FM system, recording devices, or video conferencing systems. All input signals, including microphones and auxiliary inputs are mixed and provided at the line output terminal.

(13) AUX mute setting switch [OFF/LOW/HIGH]

The Aux mute switch allows selection of whether or not the teachers voice mutes the auxiliary inputs when he or she speaks. The 'off' setting provides for no muting. The Low setting provides for a standard level of attenuation. The High setting provides for a faster attenuation. Set the switch to 'low' for normal operation.

(14) Speaker output terminal

Connections for the speakers (8 Ohms).

(15) PA input terminal

When public announcements are input into the system they are played through the speakers. The user can also select to reduce the auxiliary input levels during PA announcements by switching the EMG input Terminal (17).

(16) PA input volume

Adjusts the level of the PA system being played through the speakers

(18) Serial transmission terminal (RS-232)

Provides for remote control of system from a computer

(A) Ground screw [SIGNAL GND]

(B) Mount for cable clamp - Used to bundle cables and speaker wires with tie-wraps.

Operating Controls

RC-07 Infrared Receiver

Front View

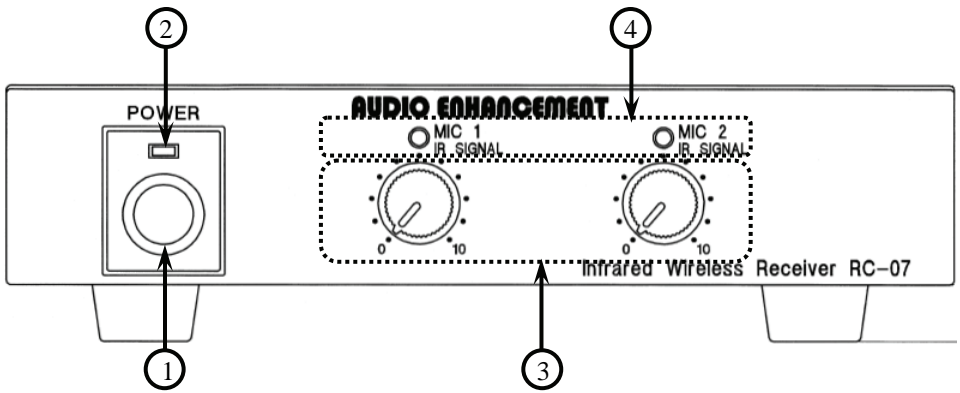

- (1) Power switch
Turns the power on/off.
- (2) Power indicator
Lights "green" when the power is turned ON.
- (3) Infrared Microphone Volume Control [Teacher 1 and 2]
This control is used to adjust the level of the infrared microphones.
- (4) Infrared Signal Indicator [MIC 1 IR SIGNAL, MIC 2 IR SIGNAL]
Lights "green" when the infrared wireless receiver is receiving a signal.

•AC adapter
Use the "3A-621DA24" AC adapter provided to supply power to the "RC-07".

Operating Controls

RC-07 Infrared Receiver

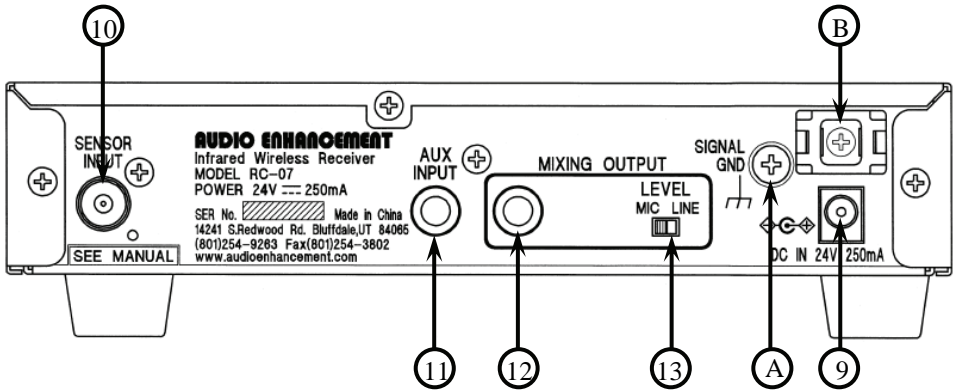

- (9) DC power terminal
The AC adapter provided supplies 24 V DC power.
- (10) Sensor input terminal
Connection via F-connector and coaxial cable for the infrared sensors.
It also supplies power to the sensors (24 V).
- (11) AUX input terminal
Connections for TV/DVD, CD, COMPUTER, and MP3 etc.
- (12) Mixing output terminal
Provides selectable line level or microphone level signal for input into external amplifier. Output provides mixed signal from both infrared microphone and auxiliary input.
- (13) Output Level Selection
Allows selection of either line level or microphone level output
- (A) Ground screw [SIGNAL GND]
- (B) Mount for cable clamp - Used to bundle cables and speaker wires with tie-wraps.

Operating Controls

STUDENT MICROPHONE

- (1A) Momentary power switch– Push to Talk.
- (1B) Continuous power switch– Slide up to lock on and then talk.
- (2) Power indicator –lights "green" when the power is turned either momentary or continuous.
- (3) Microphone (audio pickup) - speak into this part of the microphone.
- (4) Infrared signal emitters — the infrared signal is broadcast from multiple infrared signal emitters.
- (5) Battery case— Slide the battery cover down to remove.
- (6) Charging terminal—charging input for charging the batteries with the AC Adapter or the battery charger
- (7) Charging indicator—The charging indicator provides a "red" light to indicate the following conditions when the power switch is off and the microphone is being charged.
 - Charging: Solid steady ON
 - Finished Charging: OFF
 - Charging error (trying to charge an alkaline battery) : Flashing very fast
- (8) External Auxiliary input terminal (on the side) - Used to connect a CD or MP3 player or other device. Allows the user to wirelessly connect a source to the system.
- (9) Single "AA" NiMH rechargeable battery or non-rechargeable Alkaline battery.
- (10) Channel assignment switch. Channel switch (inside the battery case) - Set the channel of the infrared wireless microphone to the desired channel.

- ⊙ Channels 1 or 2 for use with Achiever, Ultimate II, Innovator. Channels 1 through 4 for use with Innovator..

●Uses two Panasonic NIMH AA rechargeable batter-



To change the battery:

1. Slide the rear cover(5) down towards the bottom of the microphone.
2. Replace battery with a standard "AA" NiMH rechargeable.

Note: A standard "AA" Alkaline cell can be used on a temporary basis.

Operating Controls

TEACHER MICROPHONE



To change the battery:

1. Slide the rear cover(5) down towards the bottom of the microphone.
2. Replace battery with a standard “AA” NiMH rechargeable.

Note: A standard “AA” Alkaline cell can be used on a temporary basis.

- (1) Power/Mute switch: Turns the power on/off. Press and hold to turn on/off. Press momentary to mute.
- (2) Power indicator—Lights green when the power is turned ON.
- (3) Microphone (audio pickup) - Speak into this part of the microphone.
- (4) Infrared signal emitter The infrared signals are broadcast from multiple IR signal emitters.
- (5) Battery case cover (on the back) Slide it down to remove. Requires 1 “AA” NiMH rechargeable battery or 1 non-rechargeable Alkaline battery.
- (6) Charging terminal Charging input for charging the batteries with the AC charger.
- (7) Charging indicator—The charging indicator provides a “red” light to indicate the following conditions when the power switch is off and the microphone is being charged.
Charging: Solid Steady ON
Finished Charging: OFF
Charging error (trying to charge an alkaline battery) : Flashing very fast
- (8) External Auxiliary input terminal (on the side)
Used to connect a CD or MP3 player or other device. Allows the user to wirelessly connect a source to the system.
- (9) External Microphone input accepts lavalieri or headband microphones.
- (10) Channel assignment switch. Channel switch (inside the battery case) - Set the channel of the infrared wireless microphone to the desired channel.
⊙ Channels 1 or 2 for use with Achiever, Ultimate II and Innovator. Channels 1 through 4 for use with Innovator. (See Page #17 for addition Channel Setting Information)
- (11) UP/DOWN Remote volume control buttons for Own (Teacher), Other (Student), and Line sources.
- (12) SELECT button –Selects which source will be controlled by the remote buttons (Own, Other, Line).
- (13) Source SELECT indicators. Show which source (Own, Other, Line) is currently selected for remote control.
- (14) ‘F’ Function button—Press to activate the selected Function ‘F1’ or ‘F2’. See ‘Function’ page on the Ultimate IISE for information on setting the Function. The ‘Own’, ‘Other’ and ‘Line’ LEDs will flash when the ‘F’ button is pressed when set to F1. These three LEDs will come on and stay on when the ‘F’ button is pressed when set to F2. In the F2 mode the ‘F’ button must be pressed and held for three seconds in order to activate. It can only be reset by powering off the microphone.

Charging the Microphone Battery



1. Plug the charger into the wall (1) to the AC mains.
2. Connect the charging plug(s) (3) to the microphone(s)
3. The red Charging LED (4) should come on and stay on during the charging process. It will extinguish when charging is completed.
4. A flashing red Charging LED indicates a charging problem. It will flash if an attempt is made to charge an Alkaline battery.

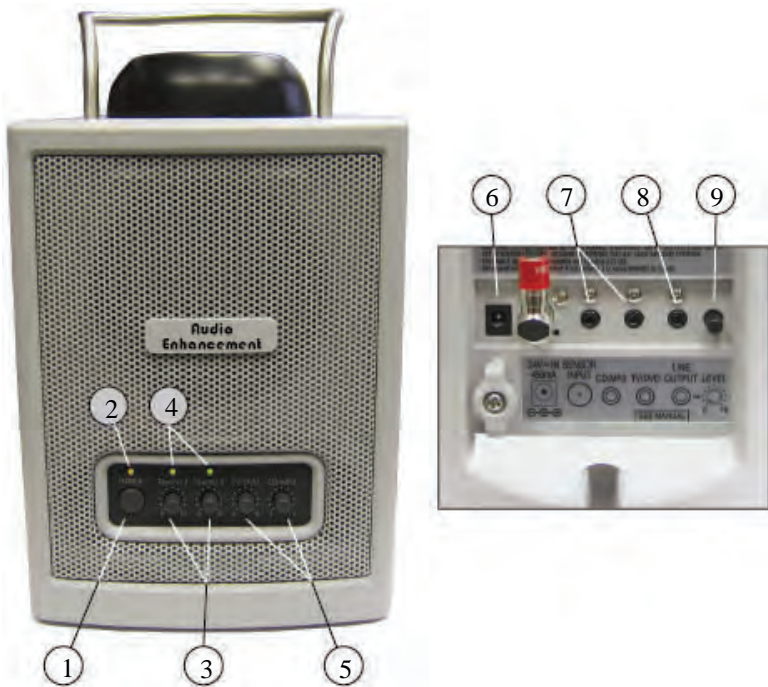

- (1) Power switch. Turns the power on/off.
- (2) Power Indicator. Lights “amber” when the power is turned ON.
- (3) Infrared Microphone Volume Control [Teacher 1 and 2]. These controls are used to adjust the level of the Teacher/Student microphones.
- (4) Infrared Signal Indicator [Teacher 1 and 2]. Lights “green” when the infrared wireless receiver is receiving a signal from a microphone.
- (5) Auxiliary Input volume Controls [TV/DVD and CD/MP3]. These controls adjust the volume of the auxiliary inputs connected to the input connectors.
- (6) Connector for AC adapter. Use adapter “3A-621DA24”.
- (7) Auxiliary line level input connectors. 3.5mm stereo mixed-to-mono.
- (8) Line level output. 3.5mm stereo (mono source).
- (9) Line level output level control.

Operating Controls

EDS-07 IR SENSOR

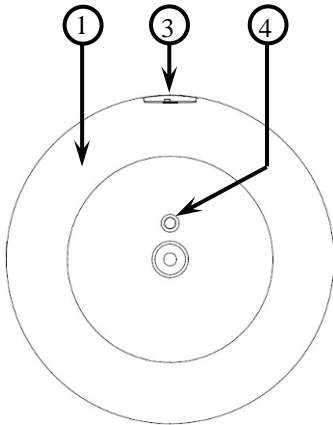

Front View

Rear View

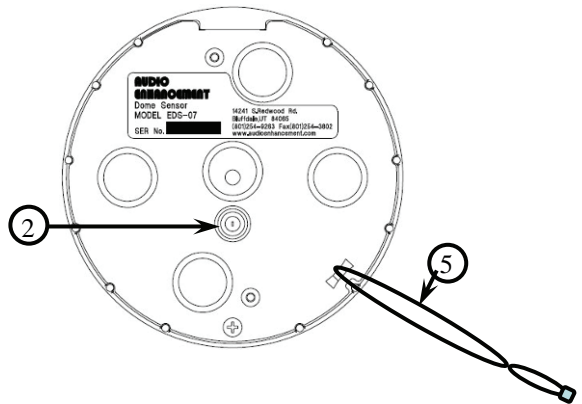

(1) Infrared sensor cover

Protects sensor and allows IR light to enter. – Power supplied by the receiver.

(2) Sensor connection terminal

Provides connection to the sensor input terminal of the infrared wireless receiver via F-connectors and coaxial cable. Power for the sensor is supplied from the receiver through the coaxial cable.

(3) Frequency selection switch [1/2, 3/4]

Switches between [1/2]: 1ch and 2ch or [3/4]: 3ch and 4ch by changing the reception frequency.

(4) Power indicator

- * Lights "green" when the frequency switch is set to [A], 1 and 2 ch.
- * Lights "orange" when the frequency switch is set to [B], 3 and 4 ch.

(5) Anchor strap

Attached to the coaxial cable to prevent the sensor from falling.

Front View



Rear View

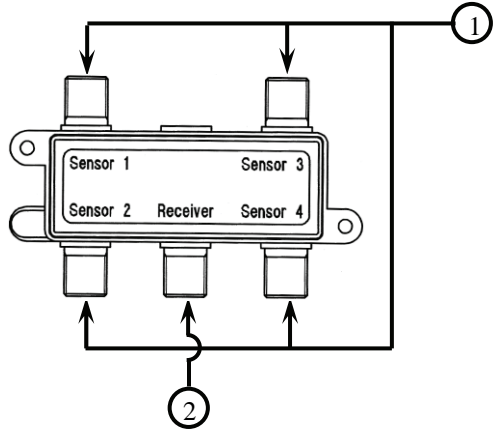

(1) Infrared Sensor Connections [F-connector]

Connect Infrared Sensors via F-connector and coaxial cable.

(2) Infrared Receiver Connection [F-connector]

Mixed infrared sensor output provides signals from the various infrared sensors. Connect to the sensor input terminal of the infrared wireless receiver via F-connectors and coaxial cable.

Operating Procedure

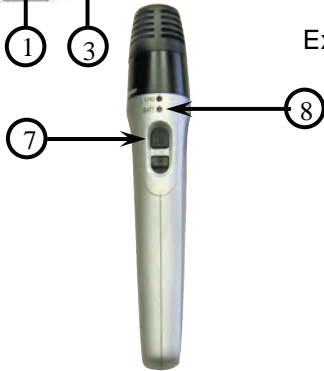
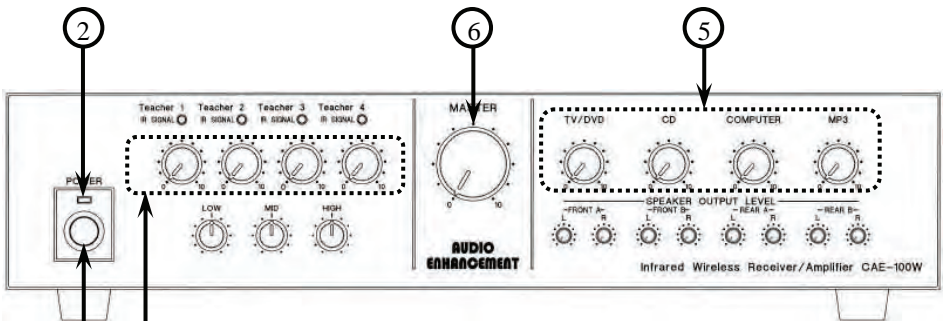

Example: Student Microphone



Example: Teacher Microphone

1. Turn the power switch on the receiver to “ON”.
(2) The power indicator lights “green”.
 2. Turn the power switch (7) on the infrared wireless microphone to “ON”.
The power indicator of the microphone lights “green”.
 3. Adjust the volume of the system
 1. Adjust the master volume (6) on the receiver to the 12-O-Clock Position
 2. Adjust the level of the appropriate infrared microphone (3).
 3. Adjust the level of the appropriate auxiliary input (5) to desired playback level.
- Ⓞ Turn the off the power of the infrared wireless microphone and the receiver when you are done using them.

Using the Remote Volume Control

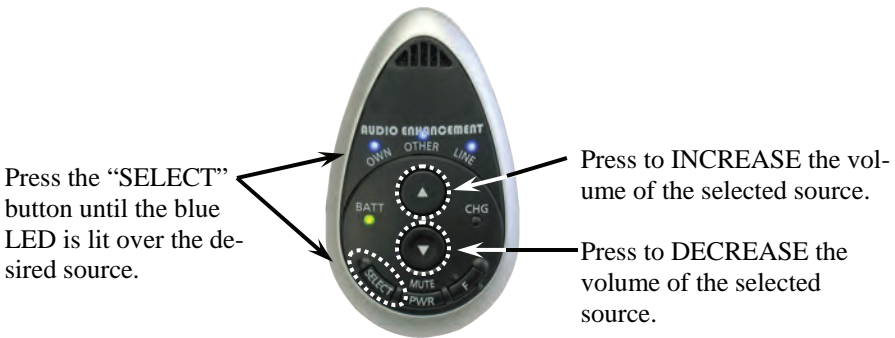

The volume level of the infrared wireless microphones and the auxiliary inputs can be controlled from the teardrop infrared wireless transmitter. To control the level infrared wireless microphones and the signal level from the auxiliary inputs.

First adjust the volume to an appropriate level with the controls that are part of the receiver/amplifier system. Once the initial volume levels are set, the teacher can then adjust the level of the his or her "OWN" microphone, the "OTHER" infrared wireless microphone in the classroom, or the auxiliary "LINE" input volume level. (The Teardrop teacher's microphone is the only microphone that has infrared remote control of the receiver/amplifier.)

- Adjusting the level of the audio signal output from the receiver.
 1. Select the source to be controlled by pressing the "SELECT" button.
Select whether to adjust the volume of your "OWN" microphone or the "OTHER" microphone or the "LINE" by selecting "OWN", "OTHER" or "LINE" by pressing the "SELECT" switch until the blue LED is lit for the desired source.
 2. Once the desired source is selected Press the volume up/down buttons.
To increase the volume level press the " " button.
To decrease the volume level press the " " button.

【notes】

The Level is adjusted in 2dB steps from +6dB to -16dB

These electronic adjustments are automatically reset to '0' when the receiver/amplifier is turned off.

The control switch for aux "LINE" inputs does not work for the Achiever amplifier and 2 channel receiver (RC-07). It does work on the Ultimate II, Innovator, and SoloSolution

Using the Microphone as a Transmitter

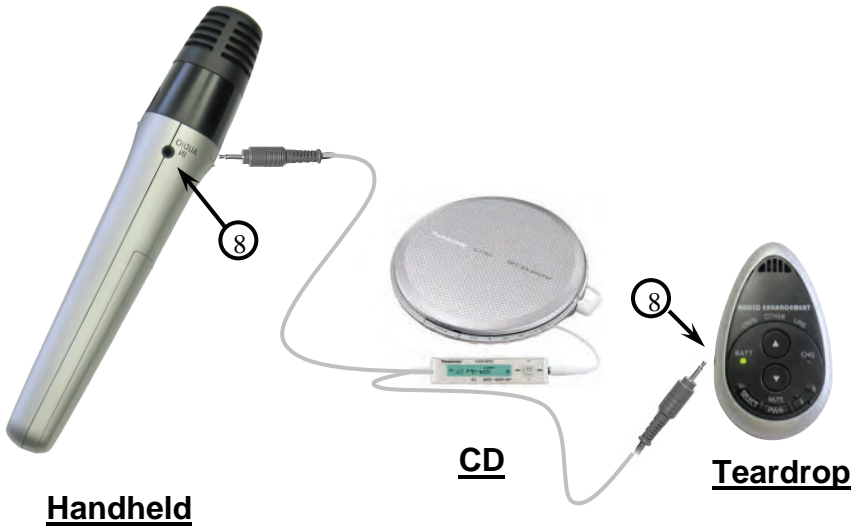

(8) External input terminal on the side of the microphone.

The infrared wireless microphone can be used as a transmitter by connecting a portable CD player or other device to the external input terminal.

1. (8) Connect an external device to the external input terminal

Connect the portable CD or MP3 player to the external input terminal (8) with a 3.5 Stereo mini plug.

【Note】

ⓈThe microphone element is muted when a plug is inserted into the external input terminal.

Setting the Aux Mute

●Setting the Mute for the Audio Input of the Infrared Wireless Microphone Reduces the volume of the auxiliary inputs when the teacher speaks into the infrared wireless microphone.

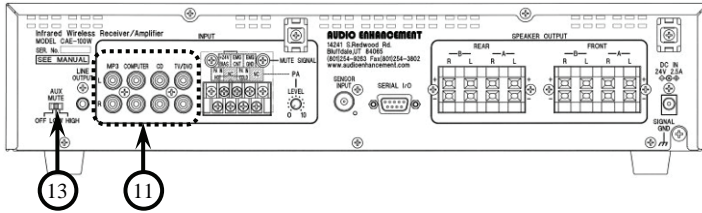

(11) Input terminal

(13) AUX mute setting switch

●Set the "(13) AUX MUTE" switch to activate this function.
"OFF" position

- The auxiliary inputs are not muted when the teacher speaks into the infrared wireless microphone.

- "LOW" and "HIGH" positions

- Reduces the volume of the auxiliary inputs while the teacher is speaking into the infrared wireless microphone. The Low setting provides for a standard level of attenuation. The High setting provides for a faster attenuation. Set the switch to 'low' for normal operation.

[Notes]

●If extraneous sounds are causing the auxiliary inputs to mute at unwanted times, set the "(13) AUX MUTE" switch in the "LOW" position. This setting will require that a sound source be closer to the microphone to activate the muting function.

The Mute functions work as depicted below:

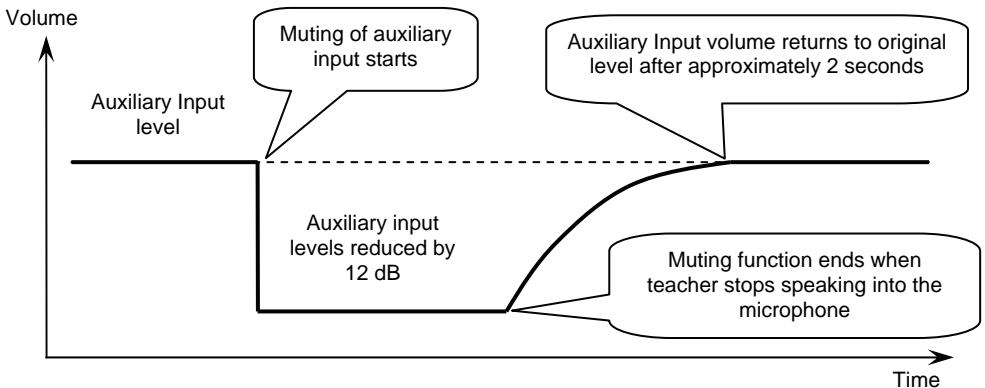

Installation

This connection diagram is an example of using 3 to 4 infrared wireless microphones with the "Innovator" infrared receiver/amplifier. When using only two microphones, one of the "EDS-07" sensors and the "AE-DCF" mixer are not necessary. In that case, set the "frequency selector switch" on the sensor according to the microphone channels being used.

If you are connecting the "Ultimate II" receiver amplifier, one or two infrared wireless microphones can be used. With this configuration one of the "EDS-07" sensors and the "AE-DCF" mixer are not necessary. With this configuration, set the "frequency selector switch" on the sensor to 1/2: 1ch and 2ch.

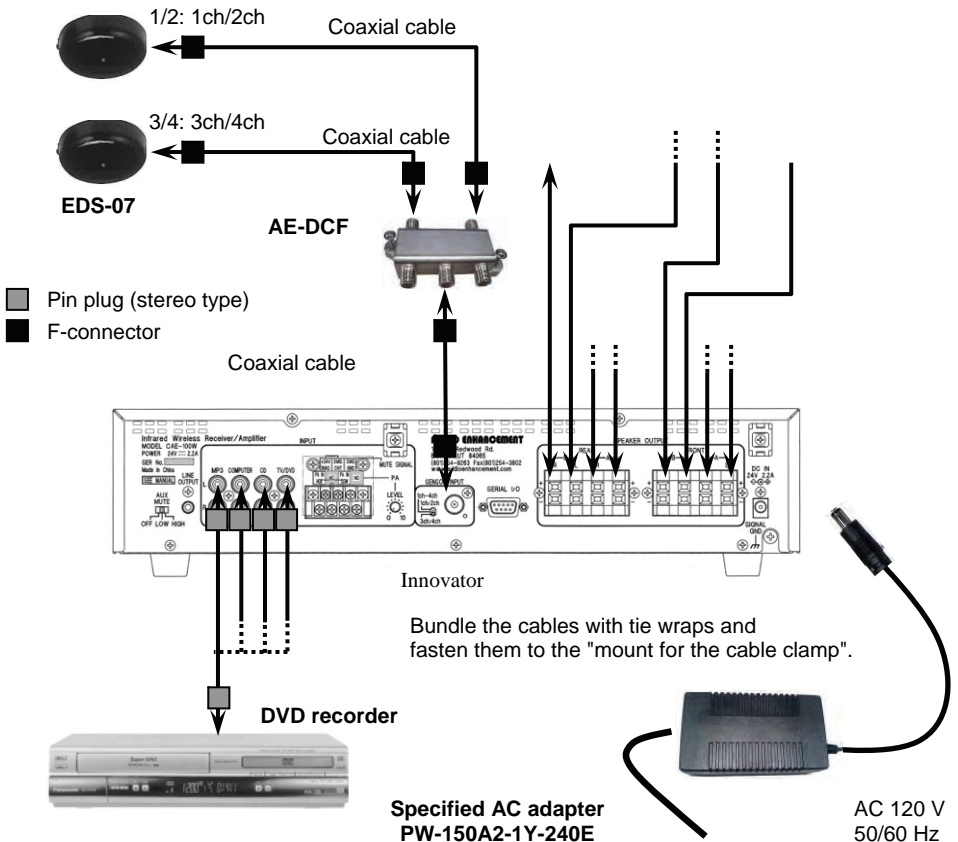

Installation

■Connections

- ⊙Remove the AC power cord from the power outlet when connecting the system.
- ⊙Use the specified AC adapter.

●Basic Connections for the "Ultimate"

⊙This connection diagram is an example of using 1 or 2 infrared wireless microphones with the "Ultimate II" infrared wireless receiver/amplifier. With this configuration set the "frequency selector switch" on the sensor to 1/2: 1ch/2ch.

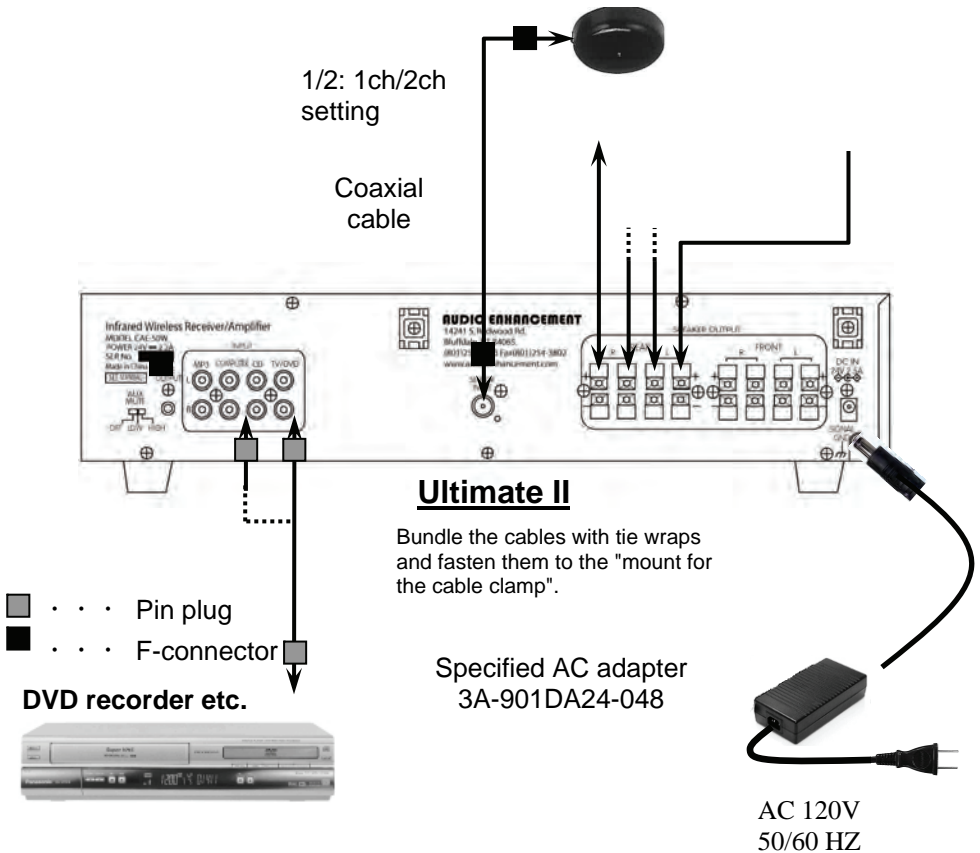

Installation

■Connections

- ⊙ Remove the AC power cord from the power outlet when connecting the system.
- ⊙ Use the specified AC adapter.

●Basic Connections for the "Achiever"

⊙ This connection diagram is an example of using 1 or 2 infrared wireless microphones with the "Achiever" infrared wireless receiver/amplifier. With this configuration set the "frequency selector switch" on the sensor to 1/2: 1ch/2ch.

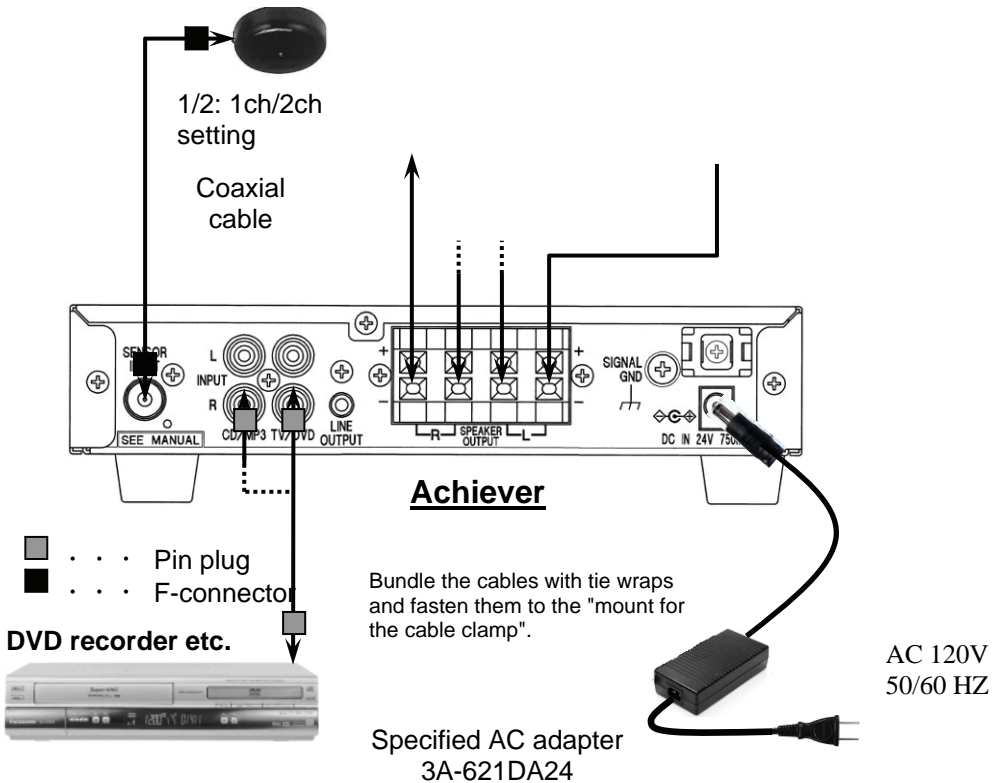

Installation

■Connections

⊙Remove the AC power cord from the power outlet when connecting the system.

⊙Use the specified AC adapter.

●Basic Connections for the "RC-07"

⊙This connection diagram is an example of using 1 or 2 infrared wireless microphone with the "RC-07" infrared receiver. With this configuration set the "frequency selector switch" on the sensor to 1/2: 1ch/2ch.

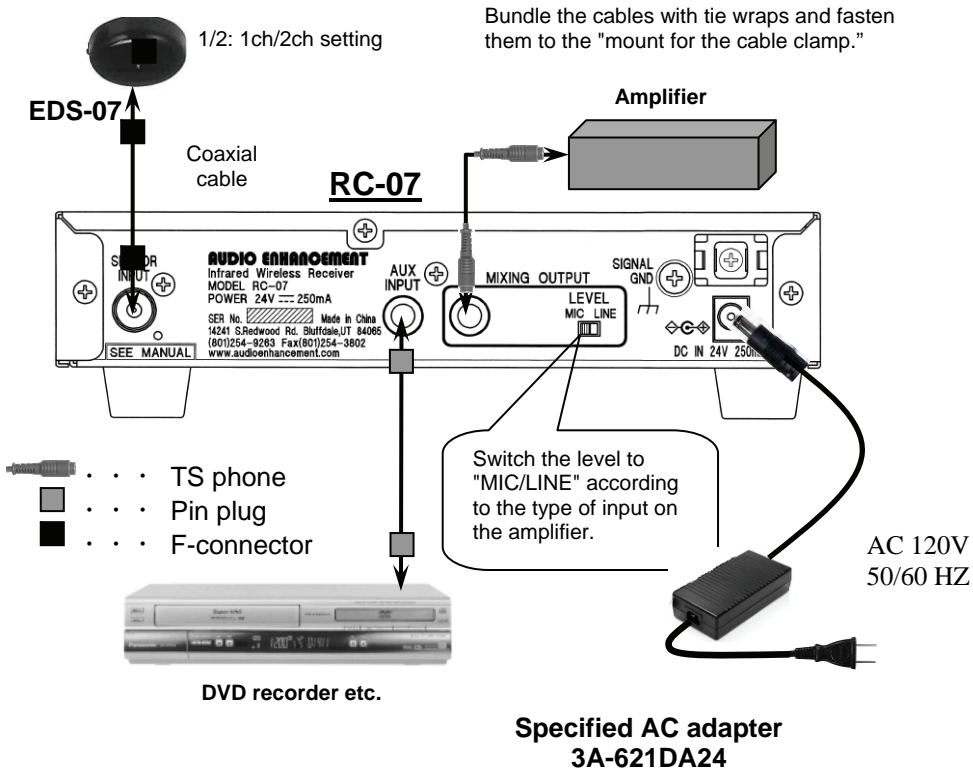

Installation

•For Reception in Large Areas

This connection diagram is an example using from 3 to 4 infrared wireless microphones with the "Innovator" receiver/amplifier. For reception in large areas, add two "EDS-07" sensors as shown below.

Up to 4 "EDS-07" sensors can be added to any receiver/amplifier. With this configuration, set all the "frequency selector switches" to 1/2: 1ch/2ch.

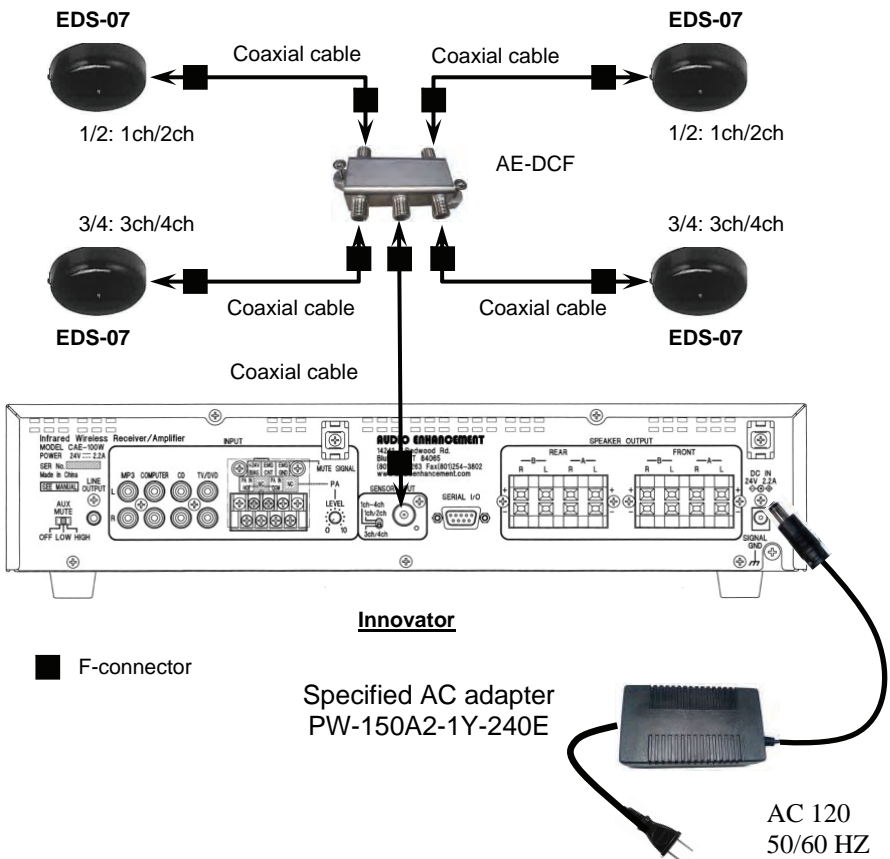

Installation

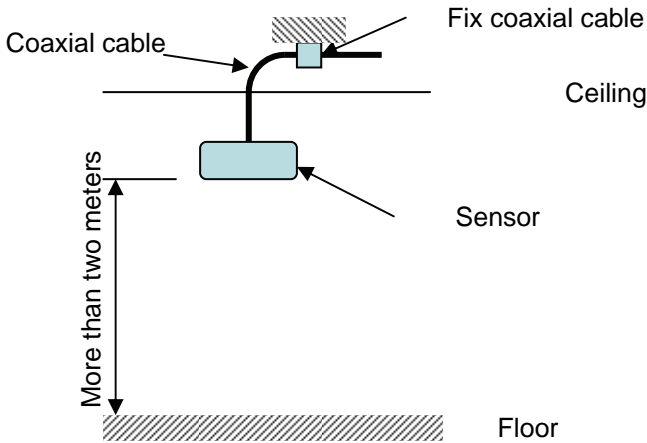

●Precautions for Installing the Sensors

- ⊙Install the infrared sensors in a position that allows them to receive the infrared signal regardless of the teachers movement around the classroom.
- ⊙Do not install the sensors in direct sunlight or directly in front of strong lighting fixtures.

In particular, in case of the sensor is installed near by a window. Even if the sensor is not in direct sunlight, reflections from sunlight may reduce the effective range of the sensor. Install the infrared sensor as far away as possible (more than 5 meters) from a window. In spite of installed far away more than 5 meters from the windows, the effective range of the sensor is not improved, try to install more and more far away from a windows, or try to use curtains or blinds for protection from the sun.

Caution: Possible Interference from Plasma Screens

Plasma screens can generate signals that interfere with IR audio systems. To reduce interference, choose a plasma display which is equipped with an optical IR filter. If this is not an option, please install IR sensor with the guidelines on page 38 in mind.

Installation

●Precautions for Installing the Sensors

- Install the infrared sensor in a position from which the screen of the plasma display cannot be seen, in other words, in the zone which is crosswise direction or behind from plasma display, and install the infrared sensor as far away as possible (more than 10 meters) from the plasma display.

- Keep the infrared microphone and the photoreceptor sensor as close as possible (less than 3 meters).

- Please use the infrared microphone keeping no screen (include human body) between the infrared microphone and the photoreceptor sensor.

- ⊙Install the infrared sensor as far away as possible (more than 1 meter) from fluorescent lighting.

- ⊙The sensors may not operate if there is a strong source of electromagnetic noise (i.e. fluorescent lighting ballasts) causing interference. Install the sensor far enough away from the noise source.

- ⊙The sensors are designed for ceiling-heights from two to four meters (6 to 12 feet). If the ceiling height exceeds this height the effective range of the sensor may be reduced.

Caution: Attach the coaxial cable used to connect the infrared sensor to the receiver to structure above the ceiling. This will prevent the sensor from falling should the screws come out. (Refer to diagram on page 34)

Installation

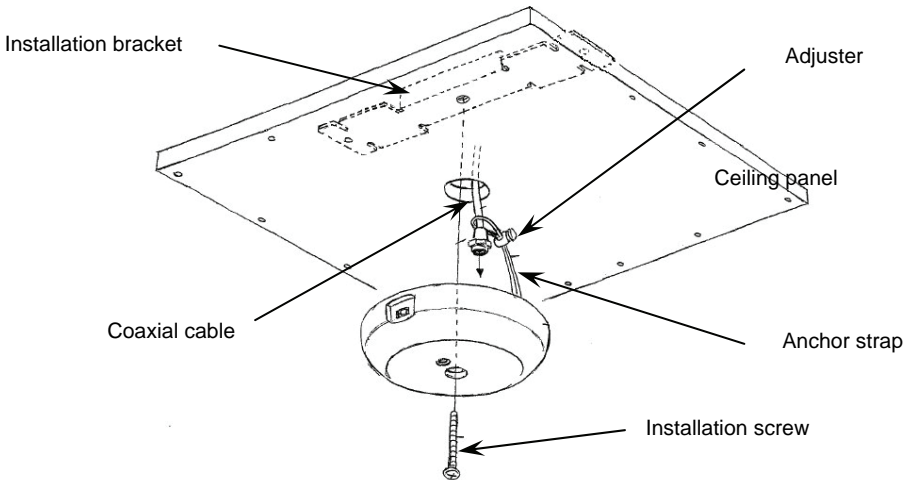

●Installing the Sensors: Part 1

Install the sensors as shown below if the coaxial cables have been routed through the ceiling and the ceiling panels can be removed.

1. Cut a hole in the ceiling panel.

Remove the ceiling panel and cut a hole about $\phi 30$ mm in it and pull the cable through it.

2. Attach the anchor strap.

Put coaxial cable through the anchor strap and tighten the adjuster.

3. Install the sensor.

Push the coaxial cable and the safety strap back into the hole.

Put the screw through the sensor and screw it into the installation bracket.

Tighten the screw.

4. After installation, make sure nothing is loose.

Do a visual check and make sure that nothing is unsteady and the screws are tight.

Installation

Installation Bracket: Diagram for bending

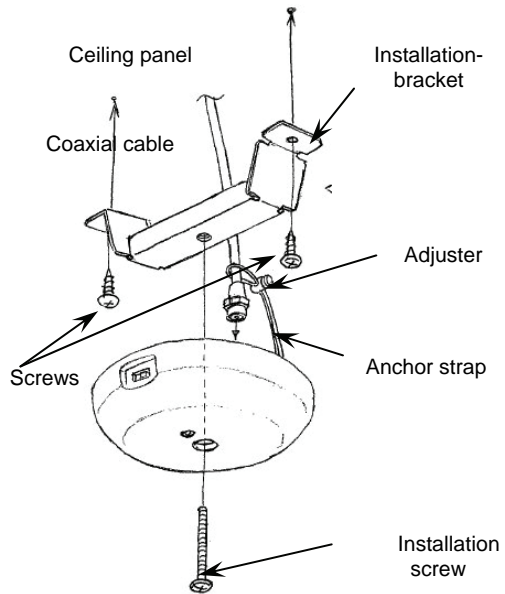
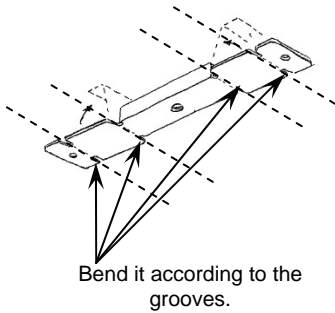

●Installing the Sensors: Part 2

If the coaxial cables cannot be routed through the ceiling, you can install the sensors as shown below if the ceiling panels cannot be removed.

- 1. Bend the installation bracket.** Bend the installation bracket as shown in the diagram above.
- 2. Attach the installation bracket to the ceiling.** Attach the installation bracket to the ceiling with the screws.
- 3. Attach the anchor strap.** Put coaxial cable through the anchor strap and tighten the adjuster.
- 4. Install the sensor.** Put the screw through the sensor and screw it into the installation bracket. Tighten the screws.
- 5. After installation, make sure nothing is loose.** Do a visual check and make sure that nothing is unsteady and the screws are tight.

Caution: The screws for attaching the installation bracket to the ceiling panel are not provided. Procure these screws separately according to the material, construction and weight of the ceiling panel.

Installation

●Range and Expansion of the Sensor Reception

- ◎One dome type infrared sensor has a practical range of approximately 24'.
 - ◎Use the "AE-DCF" mixer to increase the number of sensors to cover a larger room.
- A total of four sensors can be added by using the "AE-DCF"

Receiving from 1ch/2ch(3ch/4ch)

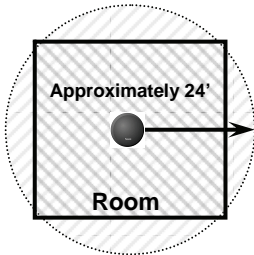

For one photoreceptor sensor

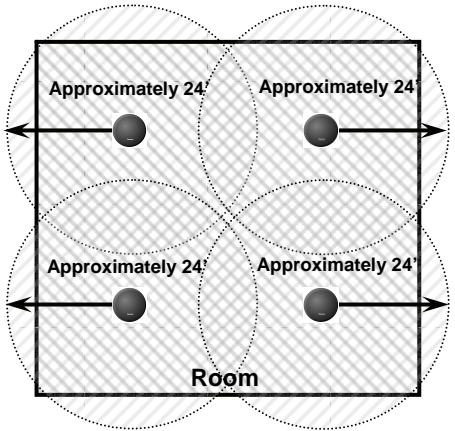

For four photoreceptor sensors

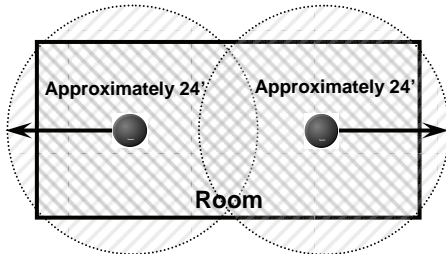

For two photoreceptor sensors

Receiving from 1ch to 4ch

● : 1ch/2ch setting ● : 3ch/4ch setting

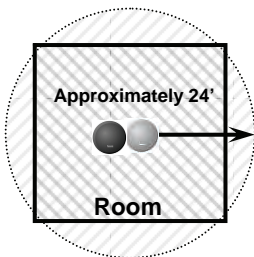

For one set of photoreceptor sensors

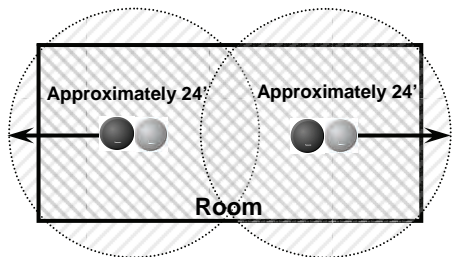

For two sets of photoreceptor sensors

Installation Coaxial Cables

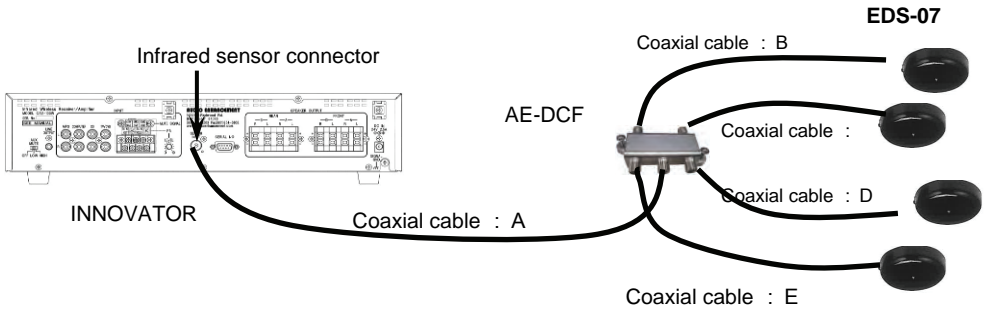

● **The following types and lengths of coaxial cables are recommended:**

Use the following lengths and types of coaxial cables to connect the main unit and the sensors.

◎ Coaxial cable length Less than 300'

◎ Coaxial cable type RG6

● **When using the "AE-DCF" sensor coupler**

Keep the total length of coaxial cable from the main unit to the coupler "coaxial cable length: A" and from the coupler to each sensor "coaxial cable length: B to E" within a range of 300 feet.

【Caution】

Keep the differences of the length among cables from AE-DCF to EDS-07 (among cables B to E) less than 36'.

Installation Coaxial Cables

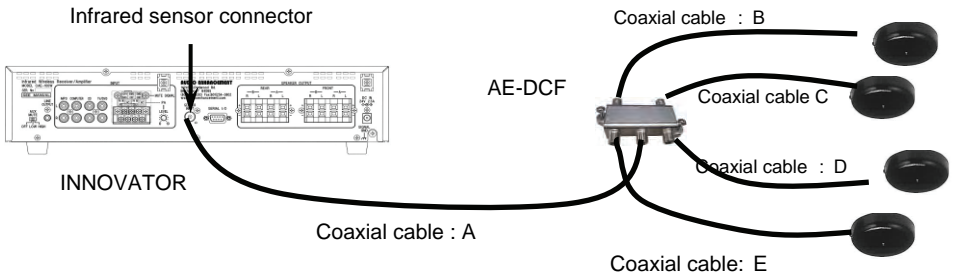

◎Part 1 [Good example]

Coaxial cable length: If $A = 120'$, $B = 24'$, $C = 12'$, $D = 18'$, $E = 30'$

【Results】

Coaxial cable: B to E are less than $36'$, and the cable length of "A: $120' + E: 30' = 150'$ ", therefore, there is no problem with a cable lengths. (It is within a range of $300'$.)

◎Part 2 [Good example]

Coaxial cable length: If $A = 180'$, $B = 90'$, $C = 105'$, $D = 75'$, $E = 99'$

【Results】

Coaxial cable: the length of cables B to E: “ (maximum: $105'$) – (minimum: $75'$) = $30'$ ”, therefore,

there is no problem with a cable length. (It is within a range of $36'$.)

The cable length of "A: $180' + C: 105' = 285'$ ", therefore, there is no problem with a cable length. (It is within a range of $300'$.)

◎Part 3 [Bad example]

Coaxial cable length: If $A = 150'$, $B = 120'$, $C = 135'$, $D = 150'$, $E = 165'$

【Results】

Coaxial cable: the length of cables B to E: “ (maximum: $165'$) – (minimum: $120'$) = $30'$ ”,

therefore, there is a problem with a cable length. (It is over the range of $36'$.)

The cable length of "A: $150' + E: 165' = 315'$ "; therefore, there is a problem with a cable length. (It is over the range of $300'$).

Setting the PA Aux Mute

(Continued from previous page)

The mute function works as shown below:

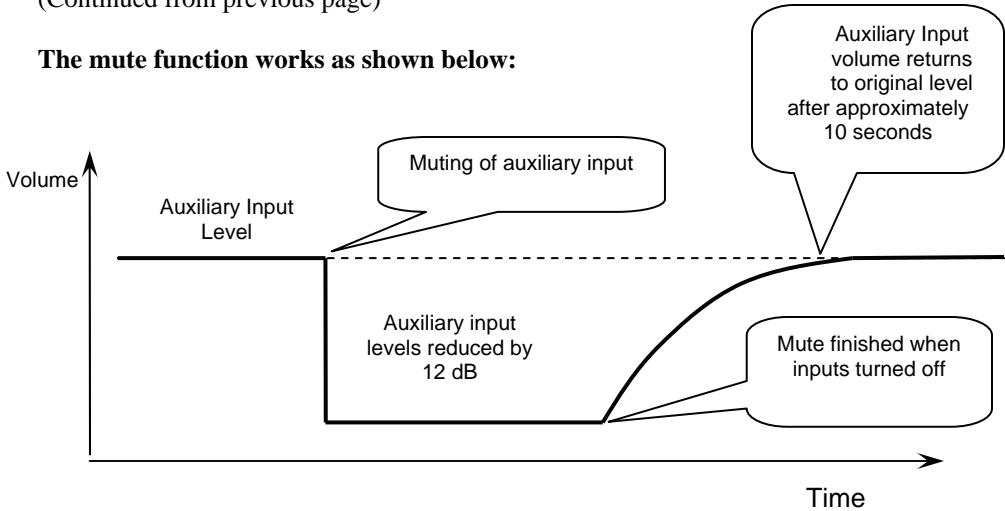

Caution : Wiring for the PA Input are fixed to the screw terminals.

The torque for the screws is $0.98 \text{ N} \cdot \text{m} \sim 0.1 \text{ N} \cdot \text{m}$

($10 \text{ kgf} \cdot \text{cm} \sim 1 \text{ kgf} \cdot \text{cm}$)

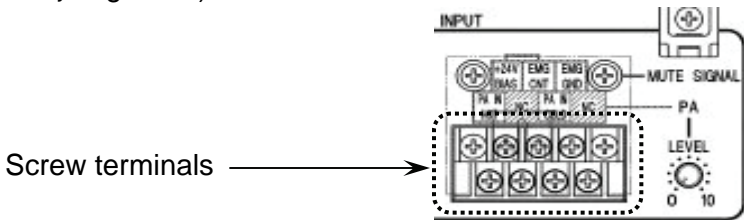

Be sure to switch the amplifier off before connecting the wires. Carefully check the polarities before connecting it. Connection to the wrong polarity will cause trouble.

Setting the PA Aux Mute

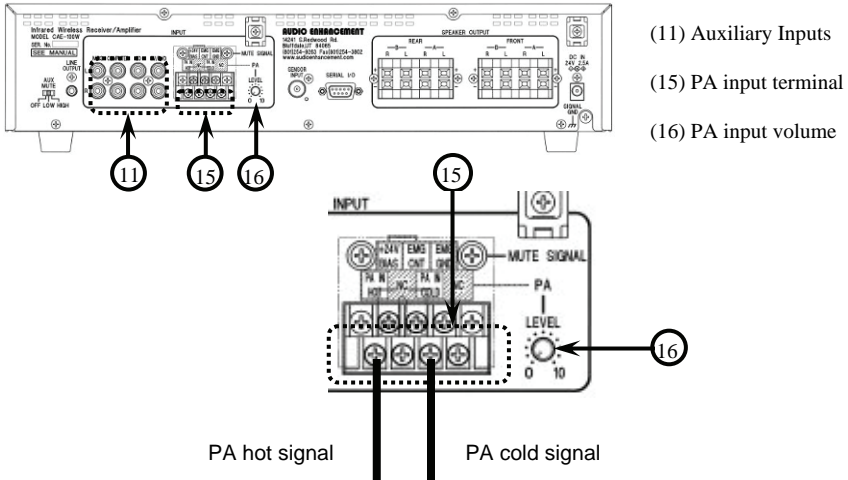

●Setting the Mute for the PA Input

The Auxiliary Muting function reduces the volume of the audio signals that are coming into the auxiliary input terminals every time an announcement over the PA system is made. This is accomplished by wiring the high impedance signal (70 or 25 Volt) from the PA system to the PA input terminals.

Adjust the audio level of the PA system that is connected to the ‘hot’ and ‘common’ terminals of the PA input terminal (15) with the PA input volume (16), as shown in the diagram.

【notes】

The AUX mute for the PA input terminal operates independently from the teacher voice mute settings.

Every time the PA system is activated, the announcement is reproduced by all of the speakers attached to the main unit.

(Continue to next page)

Setting the EMG Aux Mute

- Setting the Emergency Mute Function

The Emergency Mute Function (EMG) (17) allows selection of whether or not the audio level of the auxiliary inputs (11) is muted when a page is received from the PA system.

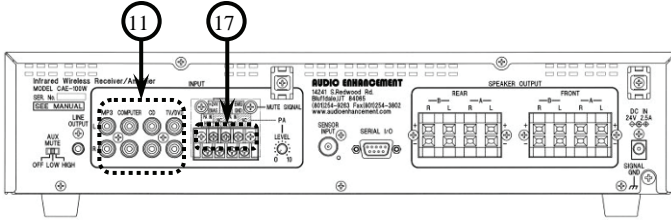

(11) Input terminal
(17) EMG input terminal

To activate the mute function, use a terminal jumper to connect the "+24 V BIAS" terminal (17) and the "EMG CNT" terminal. With the jumper in place, the auxiliary inputs will be muted when a page is received. To deactivate the muting function, connect the EMG terminal to the "EMG GND" terminal as shown in the diagram at right.

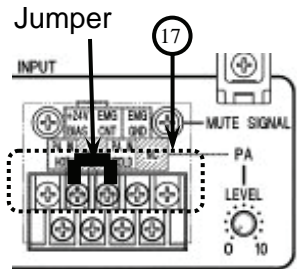

【notes】

The AUX mute for the PA input terminal operates independently from the teacher voice mute settings.

(Continue to next page)

Setting the EMG Aux Mute

(Continued from previous page)

The mute function works as shown below:

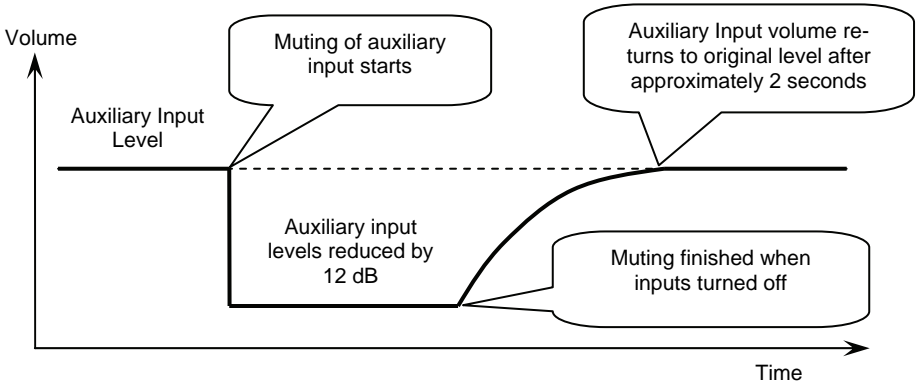

Caution : Wiring for the ENG Input are fixed to the screw terminals.

The torque for the screws is $0.98 \text{ N} \cdot \text{m} \pm 0.1 \text{ N} \cdot \text{m}$ ($10 \text{ kgf} \cdot \text{cm} \pm 1 \text{ kgf} \cdot \text{cm}$)

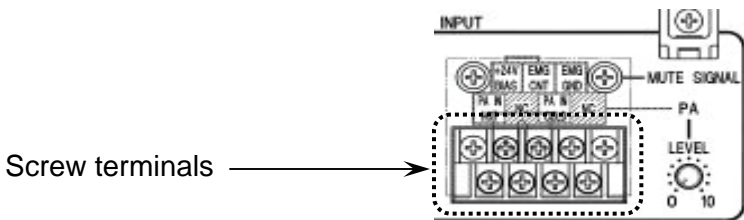

Be sure to switch the amplifier off before connecting the wires. Carefully check the polarities before connecting it. Connection to the wrong polarity will cause trouble.

About External Control

The Audio levels of the "Innovator" can be remotely controlled by connecting it to a personal computer via a serial port. The microphone levels can be controlled independently, the auxiliary inputs are controlled as a single mixed signal.

●About connections

Connect the "CAE-100W" and the personal computer with a cable as shown below.
 (18) Serial transmission terminal

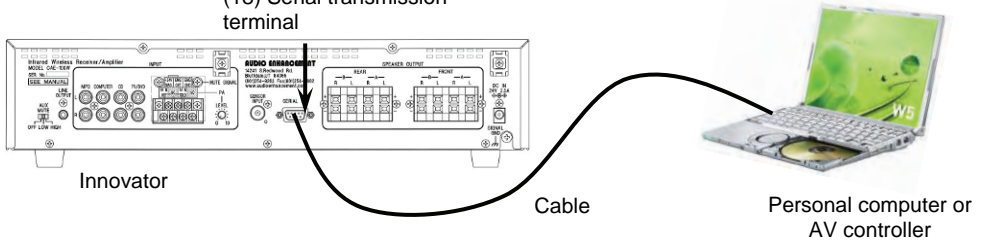

●Serial transmission connection (RS232C) specifications

The "INNOVATOR" specifications are shown below.

Signal Level	Contents	Description
Sync.method	Asynchronous	Synchronizes every 1 character (8 bits)
Baud rate	9600bps	Data transfer speed
Parity	None	Error detection method
Character length	8bits	Number of bit composing 1 character
Stop bit	1bit	Uses stop bit when asynchronous method

Cable Type : Cross
 Maximum Cable Length less than 15m (40 feet)

●Information about Connectors

PIN	NAME	PIN	NAME
1	N.C. (DCD)	6	N.C. (DSR)
2	RXD	7	N.C. (RTS)
3	TXD	8	N.C. (CTS)
4	N.C. (DTR)	9	N.C. (RI)
5	GND	---	

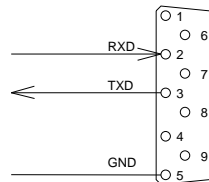

[notes]

◎Contact your local representative for additional information on controlling the Innovator from computer via the RS-232C input

Precautions for Installation

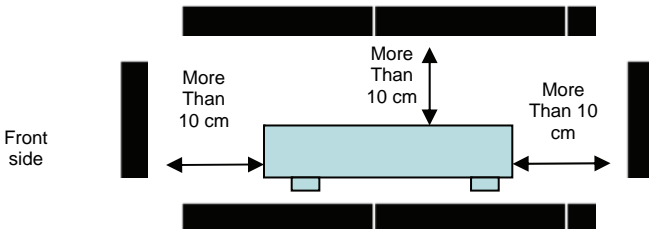

• Precautions for Installing the Infrared Receiver and Infrared Receiver/Amplifier

⊗ Infrared Receiver and Infrared Receiver / Amplifier will produce small amounts of heat. Provide a minimum of 10 cm when installing the amplifier close to the ceiling or wall. Infrared Receiver and Infrared Receiver / Amplifier are for indoor use only.

They cannot be installed and used in any of the situations below:

- In a place where they can get wet.
- Where chemicals are used including under the eaves (ex. pool)
- Places that contain high amounts of steam, oil, or a flammable atmosphere.
- Places where radiation, such as X-ray or high radio waves magnetism are present.
- On the ocean, beach or place where corrosive gas, such as hot spring is present.
- In a place where high levels of vibration are present such as on a vehicle, or marine vessel.

⊗ When using the provided bracket, note the following points.

- Select a sturdy wall to install.
- Insure that the appropriate fasteners or screws are used, and that they are rated appropriately for the load they will be required to carry.
- Insure that all the all directions from the manufacturer of the anchor, fastener or screw are followed.
- Do a visual check and make sure that nothing is unsteady and the screws are tight.

⊗ Note the following points when tightening bolts and screws.

- Proper torque must be applied to all bolts and screws.
- A torque wrench or a torque driver are required to set the proper torque.
- It is difficult to get the proper torque with an impact driver or electric driver even if it has a clutch; therefore, they should not be used as they may damage the parts for the installation.

⊗ Note the following points when installing the Innovator or Ultimate II Infrared Receiver/ Amplifier into a rack.

- When mounting to a rack, remove the rubber feet from the base of the unit.
- When installing near other heat-sensitive equipment, install the other equipment lower than the receiver/amplifier system.
- Install rack in a such a manner as to provide for sufficient airflow to maintain a temperature of no more than 40 °C in the rack.

Installing the Bracket

Installing MTBR-07L(STC-98014) for the Ultimate II and Innovator Receiver Amplifier Please carefully read the following assembly, installation and safety instructions before installation of MTBR-07L Bracket for Ultimate II and Innovator Receiver Amplifier.

1. **Installation Surface** – The enclosed accessories are suitable only for attaching to walls made of solid concrete or wood studs. Do not install to sheet rock or wood panel.
2. Tighten all the nuts using the wrench supplied with the mount. The nut must be tightened until the threading of the screw passes the plastic part of the nut.
3. Make sure that **MTBR-07L Bracket** is installed so the tray is above average head height and doesn't disturb free movement in hallways.
4. You must test the **MTBR-07L Bracket** **before** setting Ultimate II or Innovator Receiver Amplifier.
5. **Calculate the maximum weight allowed on the mount by multiplying the specified weight (this weight will be specified in the packaging of the bracket) by 1.75. (I.e. weight x 1.75).**
6. Check that Ultimate II or Innovator Receiver Amplifier is securely fastened to the bracket so it will not fall forward.
7. One month after installation and every six months after that, check that **MTBR-07L Bracket** is securely fastened to the wall and the screws and nuts are not loosening. In case of weakening, remove Ultimate II or Innovator Receiver Amplifier, and strengthen all the points that have weakened.
8. Before reinstalling **MTBR-07L Bracket**, remove Ultimate II or Innovator Receiver Amplifier first and then remount according to this manual instructions.

Installing the Bracket

Installing the UltimateII and Innovator Receiver Amplifier on MTBR-07L

Install the Ultimate II and Innovator Receiver/Amplifier as described below.

1. Fix the main unit to the bracket.

Use 2 screws to fix the bracket to the side of main unit.

2. After installation, make sure nothing is loose.

Do a visual check and make sure that nothing is unsteady and the screws are tight.

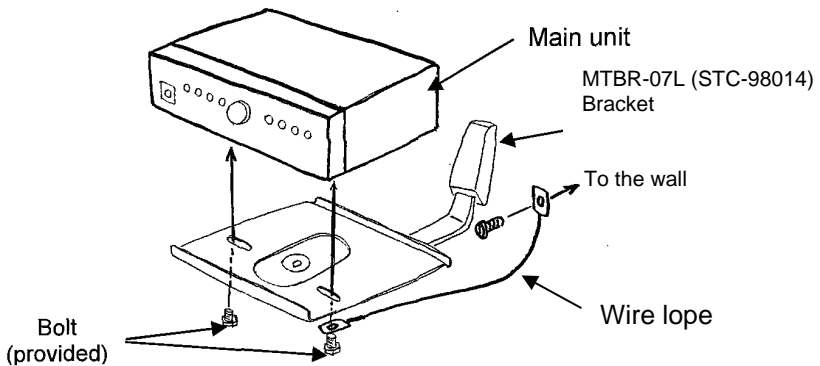

Warning for the Installation the Bracket

Fix the bracket and the wire lope to the wall.

Please secure enough strength for the installed wall.

Wire Lope Requirement

Diameter : more than $\phi 1/16$ inches

Material : High carbon steel wire rods

Caution: Please confirm to the wall there is enough strength to support the Infra-red receiver with the bracket. 106KG is five times weight about the sensor necessary above. Please do not install it in plasterboard. Please reinforce it when strength is insufficient. Please secure the AC adapter as follows when it is required to be installed higher than 30 inch from floor.

*Use metal tie-wrap and tie up two parts with something secure, 1) the brick of the AC adapter (make sure tie it using more than two tie-wraps apart from each other, 2)DC side cable at the very close point to the brick.

Installing the Bracket

Installing MTBR-07S(BT77) Bracket for Infrared Receiver RC-07 and Achiever Receiver/Amplifier

Please carefully read the following assembly, installation and safety instructions before installation of MTBR-07S Bracket for Infrared Receiver RC-07 and Achiever Receiver/Amplifier.

1. **Installation Surface** – The enclosed accessories are suitable only for attaching to walls made of solid concrete or wood studs. Do not install to sheet rock or wood panel.
2. Tighten all the nuts using appropriate wrench.
3. Make sure that **MTBR-07S Bracket** is installed so the tray is above average head height and doesn't disturb free movement in hallways.
4. You must test the **MTBR-07S** Bracket **before** setting Infrared Receiver RC-07 or Achiever Receiver/Amplifier.
5. **The maximum weight allowed on the mount is 55 lbs.**
6. Check that the Infrared Receiver RC-07 or Achiever Receiver/Amplifier is securely fastened to the bracket so it will not fall forward.
7. One month after installation and every six months after that, check that **MTBR-07S Bracket** is securely fastened to the wall and the screws and nuts are not loosening. In case of weakening, remove Infrared Receiver RC-07 or Achiever Receiver/Amplifier, and strengthen all the points that have weakened.
8. Before reinstalling **MTBR-07S** Bracket, remove the Infrared Receiver RC-07 or Achiever Receiver/Amplifier, first and then remount according to this manual instructions.

Installing the Bracket

• The Infrared Receiver RC-07 and Achiever Receiver/Amplifier on MTBR-07S

Install the Infrared Receiver RC-07 and Infrared Receiver / Amplifier Achiever as described below.

1. Fix the main unit to the bracket.

Use 2 screws to fix the bracket to the side of main unit.

The torque for the screws is $1.18 \text{ N} \cdot \text{m} \pm 0.2 \text{ N} \cdot \text{m}$ (12 kgf·cm \pm 2 kgf·cm)

2. Fix the adjustment bolts.

The torque for the screws is $1.18 \text{ N} \cdot \text{m} \pm 0.2 \text{ N} \cdot \text{m}$ (12 kgf·cm \pm 2 kgf·cm)

3. After installation, make sure nothing is loose.

Do a visual check and make sure that nothing is unsteady and the screws are tight.

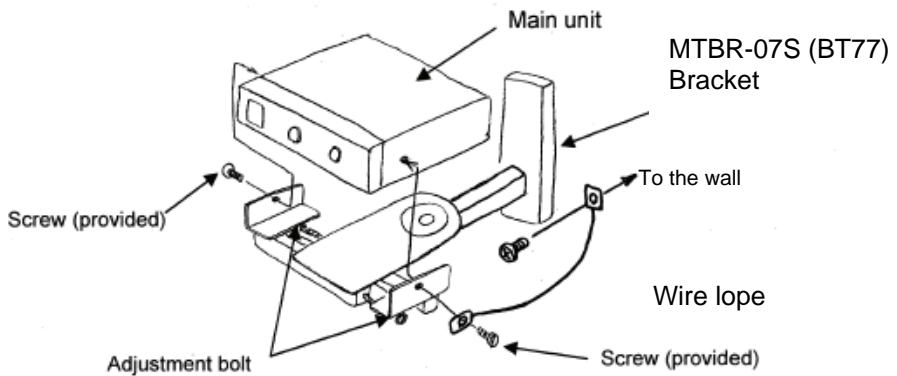

4. Fix the wire lope to the wall.

Warning for the Installation the Bracket

Fix the bracket and the wire lope to the wall.

Please secure enough strength for the installed wall.

Wire Lope Requirement

Diameter : more than $\phi 1/16$ inches

Material : High carbon steel wire rods

Caution: Please confirm to the wall there is enough strength to support the Infrared Receiver with the bracket. 106KG is five times weight about the sensor necessary above. Please do not install it in plasterboard. Please reinforce it when strength is insufficient.

Please secure the AC adapter as follows when it is required to be installed higher than 30 inch from floor.

*Use metal tie-wrap and tie up two parts with something secure, 1) the brick of the AC adapter (make sure tie it using more than two tie-wraps apart from each other, 2) DC side cable at the very close point to the brick.

Fuse Part Numbers

Manufacturer: Littelfuse, Inc.
 Series: 218

TABLE: Part Number of Fuse

	Innovator	Ultimate II	Achiever	RC-07
F101	021806.3MXP	0218004.MXP	021802.5MXP	0218.315MXP
F401	0218002.MXP	0218002.MXP	0218002.MXP	
F402	0218002.MXP	0218002.MXP	0218002.MXP	
F403	0218002.MXP	0218002.MXP		
F404	0218002.MXP	0218002.MXP		
F701	0218002.MXP			
F702	0218002.MXP			
F703	0218002.MXP			
F704	0218002.MXP			

Teacher's Check List



TURN on the transmitter (green LED will indicate power, red LED indicates that batteries need to be recharged).

POWER on the amplifier (red LED will indicate power; green LED by teacher volume control indicates receipt of IR signal).

TRANSMITTER/MICROPHONE needs to be worn in a way as to have a clear path to the receiving sensors.

POSITION the transmitter/microphone six inches from your mouth.

RELAX and speak at a comfortable level. Remember, you do not have to project your voice.

CHARGE the batteries every day. Ni-MH batteries will last for 6-8 hours of continuous use. Recharge for at least 12 hours (overnight). (Ni-MH-Batteries need to be replaced annually.)

HAVE ANOTHER PERSON MONITOR your amplified voice from time to time to make sure it is not too loud.

Troubleshooting

Transmitter is not working

Is the battery light on your transmitter green?

YES – Is the red light on your external sensor on?

YES – Is there anything in the room blocking the sensor?

YES – Move the obstruction and retry. If the problem is not fixed please contact Audio Enhancement.

NO – Is there anything covering the transmitter?

YES – Free the transmitter from any obstructions.

NO – Contact Audio Enhancement.

NO – Contact Audio Enhancement for assistance.

NO – Have your batteries been charged overnight?

YES – Are your batteries over 1 year old?

YES – Try a new set of batteries. If the problem persists contact Audio Enhancement.

NO – When charging, verify the charger is fully plugged into outlet. If the problem persists contact Audio Enhancement.

NO – Charge the batteries overnight.

Troubleshooting

No Audio

Is your power supply plugged into the amplifier/receiver and the wall outlet?

YES – Is the power switch set to “On” and the indicator light red?

YES – Is the teacher transmitter turned on with a green battery light?

YES – Is the green indicator light on the amplifier/receiver for Teacher 1 or 2 on?

YES – Try another transmitter in your room to determine if it works and contact Audio Enhancement.

NO – Verify if a red light is showing on the dome sensor and contact Audio Enhancement.

NO – Are your batteries fully charged?

YES – If the batteries are more than 1 year old please replace the batteries. If the problem persists contact Audio Enhancement for assistance.

NO – Charge the batteries overnight.

NO – Will other items power up in that outlet?

YES – If available try another outlet. If the problem persists contact Audio Enhancement.

NO – Contact the school

NO – Plug in the amplifier/receiver to the wall outlet.

Repair Form

AUDIO ENHANCEMENT

Ship Equipment to:

Attn: Repairs
14241 S. Redwood Rd
PO Box 2000
Bluffdale, UT 84065
800-383-9362

Please call for RMA# before returning
product(s)

RMA# _____

Repair Form

Name: _____

School/Company: _____

Shipping Address: _____

Attn: _____

City/State/Zip: _____

Telephone: (____) _____

Model #/Items

Serial # & Channel #

Reason for Return

Model #/Items	Serial # & Channel #	Reason for Return

Billing Address: _____

Attn: _____

City/State/Zip: _____

Telephone: (____) _____

Date Purchased: _____ Invoice # _____

***Please attach a copy of the invoice for proof of warranty. If out of warranty, Purchase Order Number must be provided.**

Is system under a purchased extended warranty/contract?

Yes

No

Purchase Order #: _____

Credit Card # (Visa/MasterCard/Discover/American Express): _____

Expiration Date: _____ Name on Card _____

Address for Card: _____

Authorized Signature: _____

Power Cords for EU

Innovator—CAE-100W

Specified AC adapter
PW-150A2-1Y-240E



AC 220 - 240 V
50/60 Hz

Ultimate II—CAE-100W

Specified AC adapter
3A-901DA24-048



AC 220—240V
50/60 HZ

Achiever—CAE-20W
Receiver—RC-07

Specified AC adapter
3A-621DA24



AC 220—240V
50/60 HZ

Safety Instructions for EU

Power disconnection. Unit with or without ON-OFF switches have power supplied to the unit whenever the power cord is inserted into the power source; however, the unit is operational only when the ON-OFF switch is in the ON position. Unplug the power cord to disconnect the main power for all units.

FOR YOUR SAFETY PLEASE READ THE FOLLOWING TEXT CAREFULLY

This appliance is supplied with a moulded three pin mains plug for your safety and convenience. A 13 amp (CAE-100W) and 3 amp (CAE-50W, CAE-20W, RC-07) fuse is fitted in this mains plug. Shall the fuse need to be replaced, please ensure that the replacement fuse has a rating of 13 amp (CAE-100W) and 3 amp (CAE-50W, CAE-20W, RC-07) and that it is approved by ASTA or BSI to BS1362.



Check for the ASTA mark or the BSI mark on the body of the fuse. If the plug contains a removable fuse cover you must ensure that it is refitted when the fuse is replaced. If you lose the fuse cover, the plug must not be used until a replacement cover is obtained.

IF THE FITTED MOULDED PLUG IS UNSUITABLE FOR THE SOCKET OUTLET IN YOUR HOME THEN THE FUSE SHOULD BE REMOVED AND THE PLUG CUT OFF AND DISPOSED OF SAFELY. THERE IS A DANGER OF SEVERE ELECTRICAL SHOCK IF THE CUT OFF PLUG IS INSERTED INTO ANY 13 AMP SOCKET.

If a new plug is to be fitted please observe the wiring code as shown below. If in any doubt, please consult a qualified electrician.

WARNING: This apparatus must be earthed.

IMPORTANT

The wires in this mains lead are coloured in accordance with the following code:

Green and yellow:	Earth
Blue:	Neutral
Brown:	Live

As the colours of the wire in the mains lead of this appliance may not correspond with the coloured markings identifying the terminals in your plug, proceed as follows.

Safety Instructions for EU

 The wire which is coloured **green and yellow** must be connected to the terminal in the plug which is marked with the letter **E** or by the earth symbol or coloured **green** or **green and yellow**.

The wire which is coloured **blue** must be connected to the terminal in the plug which marked with the letter **N** or coloured **black**.

The wire which is coloured brown must be connected to the terminal in the plug which is marked with the letter **L** or coloured **red**.

How to replace the fuse

Open the fuse compartment with a screwdriver and replace the fuse and the fuse cover.

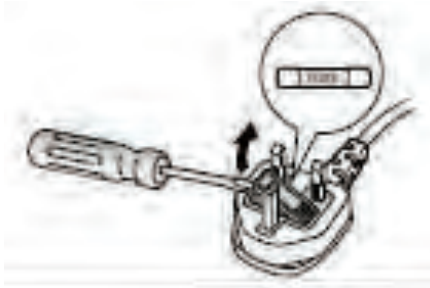

WEEE Fitting

Information on Disposal for Users of Waste Electrical & Electronic Equipment (private households)



This symbol on the products and/or accompanying documents means that used electrical and electronic products should not be mixed with general household waste.

For proper treatment, recovery and recycling, please take these products to designated collection points, where they will be accepted on a free of charge basis. Alternatively, in some countries you may be able to return your products to your local retailer upon the purchase of an equivalent new product.

Disposing of this product correctly will help to save valuable resources and prevent any potential negative effects on human health and the environment which could otherwise arise from inappropriate waste handling. Please contact your local authority for further details of your nearest designated collection point.

Penalties may be applicable for incorrect disposal of this waste, in accordance with national legislation.

For business users in the European Union

If you wish to discard electrical and electronic equipment, please contact your dealer or supplier for further information.

Information on Disposal in other Countries outside the European Union

This symbol is only valid in the European Union. If you wish to discard this product, please contact your local authorities or dealer and ask for the correct method of disposal.

Company Name:	Alura Group BV
Address:	Molenstraat 15 2513 BH The Hague The Netherlands
Phone:	(31) (0) 70 362-4896
Fax:	(31) (0) 84 838-5552

Standard 5-year Warranty

Audio Enhancement (“Provider”) is pleased to offer a standard Five (5) year limited manufacturers warranty (“Limited Warranty”) against malfunction due to manufacturing defects in materials or workmanship on the teardrop microphone, handheld microphone, receiver/amplifier systems, the external infrared sensors, and speakers (“Provider Products”). Optional accessories are warranted under the same terms for a period of 1 year. The ‘AA’ NiMH Batteries supplied by Audio Enhancement carry a 90 day warranty from date of purchase.

The Limited Warranty applies only if: (1) the Provider Products are installed according to Provider’s instruction provided to Customer or (2) the Provider Products are not misused or abused, and there is no evidence of mishandling, neglect, modification or repair without the approval of Provider, or damage done to Provider’s Products by anyone other than Provider.

The following is not included under this Limited Warranty: (1) Misuse or abuse by the Customer; (2) normal wear and tear; and (3) physical damage to Provider’s Products as a result of unreasonable use and/or negligence.

This Limited Warranty is provided by Provider, and it contains the only express warranty provided to Customer by Provider. Provider does not authorize any other person, including distributors, to give any other warranties on Provider’s behalf.

Provider disclaims any express warranty not provided herein and any implied warranty, guaranty or representation as to performance, quality and absence of hidden defects, and any remedy for breach of contract, which but for this provision, might arise by implication, operation of law, custom of trade or course of dealing, including implied warranties of merchantability and fitness for a particular purpose. Provider further disclaims any responsibility for losses, expenses, inconveniences, special, indirect, secondary, or consequential, incidental, and contingent damages whatsoever, including damages arising from ownership or use of provider’s products

Provider shall bear no responsibility or obligation with respect to the manner of use of any equipment sold by Provider.

Provider specifically disclaims and negates any warranty of fitness for a particular purpose of such equipment including, without limitation, any warranty that the use of such equipment for any purpose will comply with applicable laws and regulations or overcome any specific hearing/auditory processing deficit. When returning units for service, use adequate packaging to prevent shipping damage. Shipping damage is not covered under warranty.

**PLEASE DOUBLE CHECK BATTERIES BEFORE SENDING
UNITS FOR SERVICE.**

14241 South Redwood Road PO Box 2000 Bluffdale UT 84065
Toll Free: (800) 383-9362 Phone: (801) 254-9263 Fax: (801) 254-3802

AudioEnhancement.com