

# DM™ 309

*Owner's Manual*

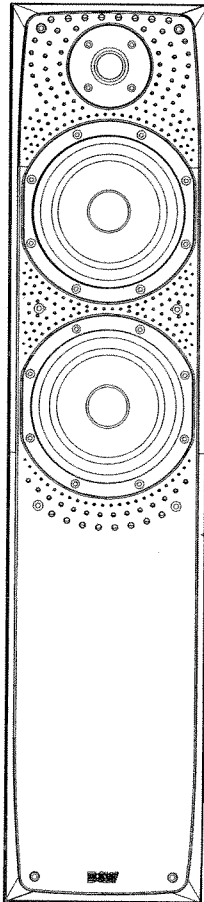

Bowers & Wilkins

Figure 1

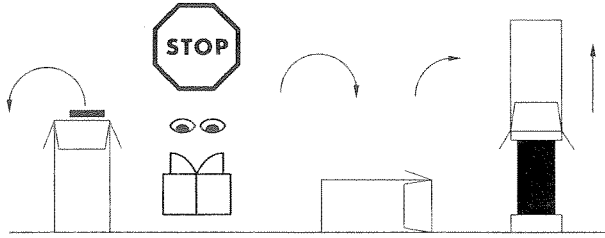

Figure 2

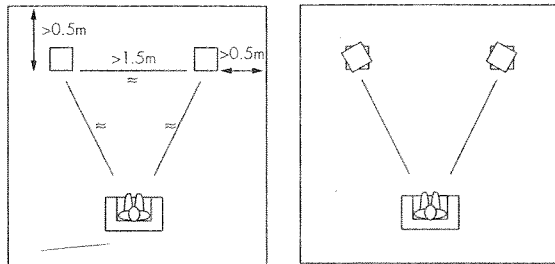

Figure 3

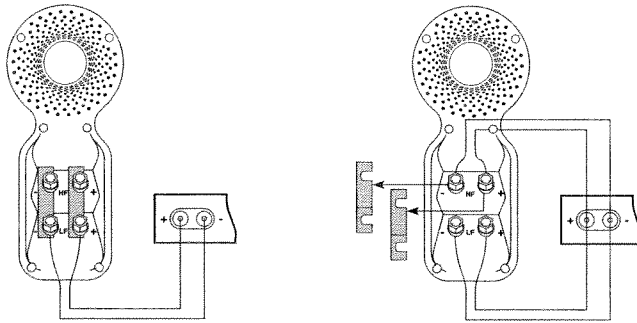
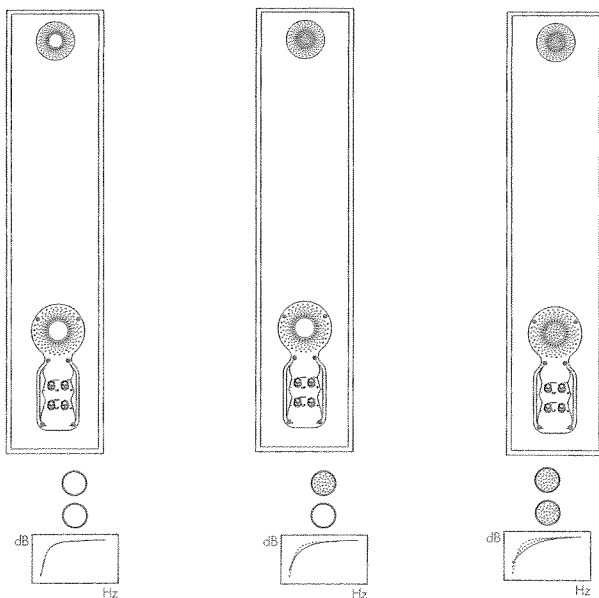

Figure 4



**DM™309  
Owner's manual**

English ..... 1

Français ..... 2

Deutsch ..... 3

Español ..... 4

Português ..... 5

Italiano ..... 6

Nederlands ..... 7

Ελληνικά ..... 9

中文 ..... 10

日本語 ..... 11

Česky ..... 12

Polski ..... 13

Русский ..... 14

Slovensko ..... 15

Dansk ..... 16

Suomi ..... 17

Svenska ..... 18

Magyar ..... 19

## ENGLISH

### INTRODUCTION

Thank you for choosing Bowers & Wilkins.

We are confident that you will enjoy many years of listening pleasure from your speakers, but please read this manual fully before installing them. It will help you optimise their performance.

B&W maintains a network of dedicated distributors in over 60 countries who will be able to help you should you have any problems your dealer cannot resolve.

### UNPACKING

(figure 1)

- Fold the carton flaps right back and invert the carton and contents.
- Lift the carton clear of the contents.
- Remove the inner packing from the product.

We suggest you retain the packing for future use.

Check in the carton for:

- 2 foam plugs.
- 4 spike feet with lock nuts.

### POSITIONING

(figure 2)

Do not fit the spike feet until you have found the best position for your speakers.

As an initial guide:

- Position the speakers and the centre of the listening area approximately at the corners of an equilateral triangle.
- Keep the speakers at least 1.5m apart to maintain left-right separation.
- Keep the speaker baffles at least 0.5m clear of walls.

### Stray magnetic fields

The speaker drive units create stray magnetic fields that extend beyond the boundaries of the cabinet. We recommend you keep magnetically sensitive articles (television and computer screens, computer discs, audio and video tapes, swipe cards and the like) at least 0.5m from the speaker.

### CONNECTIONS

(figure 3)

All connections should be made with the equipment switched off.

There are 2 pairs of terminals at the back of the speaker which permit bi-wiring if desired. On delivery, the separate pairs are connected together with high-quality links for use with a single 2-core cable. For single cable connection, leave the links in place and use either pair of terminals on the speaker.

Ensure the positive terminal on the speaker (marked + and coloured red) is connected to the positive output terminal of the amplifier and negative (marked – and coloured black) to negative. Incorrect connection can result in poor imaging and loss of bass.

To bi-wire, remove the links by loosening the terminal caps and use a separate 2-core cable from the amplifier to each pair of terminals. This can improve the resolution of low-level detail. Observe the correct polarity as before. When bi-wiring, incorrect connection can also impair the frequency response.

The terminals accept 5mm (<sup>5</sup>/<sub>16</sub>-in) spades, bared wire ends or round pins up to 5mm diameter and 4mm banana plugs. When using spades, fit them under the sliding collar.

#### Important safety notice:

*In certain countries, notably those in Europe, the use of 4mm banana plugs is considered a potential safety hazard, because they may be inserted into the holes of unshuttered mains supply sockets. In order to comply with European CENELEC safety regulations, the 4mm holes in the ends of the terminals are blocked by plastic pins. Do not remove the pins if you are using the product where these conditions apply.*

Always screw the terminal caps down tightly to optimise the connection and prevent rattles.

Ask your dealer for advice when choosing cable. Keep the total impedance below the maximum recommended in the specification and use a low inductance cable to avoid attenuation of the highest frequencies.

### FINE TUNING

Before fine tuning, double check that all the connections in the installation are correct and secure.

Moving the speakers further from the walls will reduce the general level of bass. Space behind the speakers also helps to create an impression of depth. Conversely, moving the speakers closer to the walls will increase the level of bass.

If you want to reduce the bass level without moving the speakers further from the wall, fit the foam plugs in the port tubes (figure 4).

If the bass is uneven with frequency it is usually due to the excitation of resonance modes in the room. Even small changes in the position of the speakers or the listeners can have a profound effect on how these resonances affect the sound. Try mounting the speakers along a different wall. Even moving large pieces of furniture can have an effect.

If the central image is poor, try moving the speakers closer together or toeing them in so they point at or just in front of the listeners (figure 2).

If the sound is too harsh, increase the amount of soft furnishing in the room (for example use heavier curtains), or reduce it if the sound is dull and lifeless.

Test for flutter echoes by clapping your hands and listening for rapid repetitions. Reduce them by the use of irregular shaped surfaces such as bookshelves and large pieces of furniture.

Ensure the speakers stand firmly on the floor. Whenever possible fit the spike feet supplied after you have optimised the positioning. They are designed to pierce through carpeting to the floor surface. Initially, screw the lock nuts fully onto the spikes and screw the spikes fully into the threaded inserts in the base of the speaker. If the cabinet rocks, unscrew the appropriate spikes until the speaker stands firmly on the floor and lock them in place by tightening the lock nuts against the base. If you do not have a carpet, use a protective disc under the spikes to protect the floor surface.

### AFTERCARE

The cabinet surface usually only requires dusting. If you wish to use an aerosol cleaner, remove the grille first by gently pulling it away from the cabinet. Spray onto the cleaning cloth, not directly onto the cabinet. The grille fabric may be cleaned with a normal clothes brush whilst the grille is detached from the cabinet.

Avoid touching the drive unit diaphragms, especially the tweeter, as damage may result.

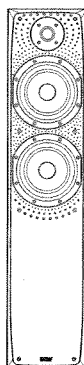
**DM™309**

<b>Technical features</b>	Nautilus™ tweeter Flowport™
<b>Description</b>	2½-way vented-box system
<b>Drive units</b>	1x ø25mm (1 in) alloy dome high-frequency 1x ø130mm (6.0in) woven fibreglass cone bass/midrange 1x ø130mm (6.0in) woven fibreglass cone bass
<b>Frequency range</b>	-6dB at 40Hz and 42kHz
<b>Frequency response</b>	60Hz – 22kHz ±3dB on reference axis
<b>Dispersion</b>	Within 2dB of reference response Horizontal: over 40° arc Vertical: over 10° arc
<b>Sensitivity</b>	88dB spl (2.83V, 1m)
<b>Harmonic distortion</b>	2nd and 3rd harmonics (90dB, 1m) <1% 90Hz – 20kHz
<b>Nominal impedance</b>	8Ω (minimum 3.0Ω)
<b>Crossover frequency</b>	150Hz, 4kHz
<b>Recommended amplifier power</b>	25W – 120W into 8Ω on unclipped programme
<b>Max. recommended cable impedance</b>	0.1Ω
<b>Dimensions</b>	Height: 910mm (35.8in) Width: 201mm (7.9in) Depth: 305mm (12in)
<b>Net weight</b>	19.5 kg (42.9 lb)

**LISTEN AND YOU'LL SEE**

B&W Loudspeakers Ltd. reserves the right to amend details of the specification without notice in line with technical developments.  
Copyright © B&W Loudspeakers Ltd. Printed in England. E & OE.

B&W Loudspeakers Ltd, Meadow Road, Worthing, BN11 2RX, England

Tel: +44 (0) 1903 524801 Fax: +44 (0) 1903 524725 [www.bwspeakers.com](http://www.bwspeakers.com)